



Petula by Fibre ood

Petula by Fibre



4 - 32

Following in Twiggy's footsteps: this playful A-line dress is not only wonderfully summery, it also looks cheerful and exciting with its sixties vibes. You can lengthen the dress or make it even shorter if you dare... Petula has a concealed zip and princess seams combined with a dart for a beautiful fit. The elegant neck and arm cut has been finished with an all in one facing.

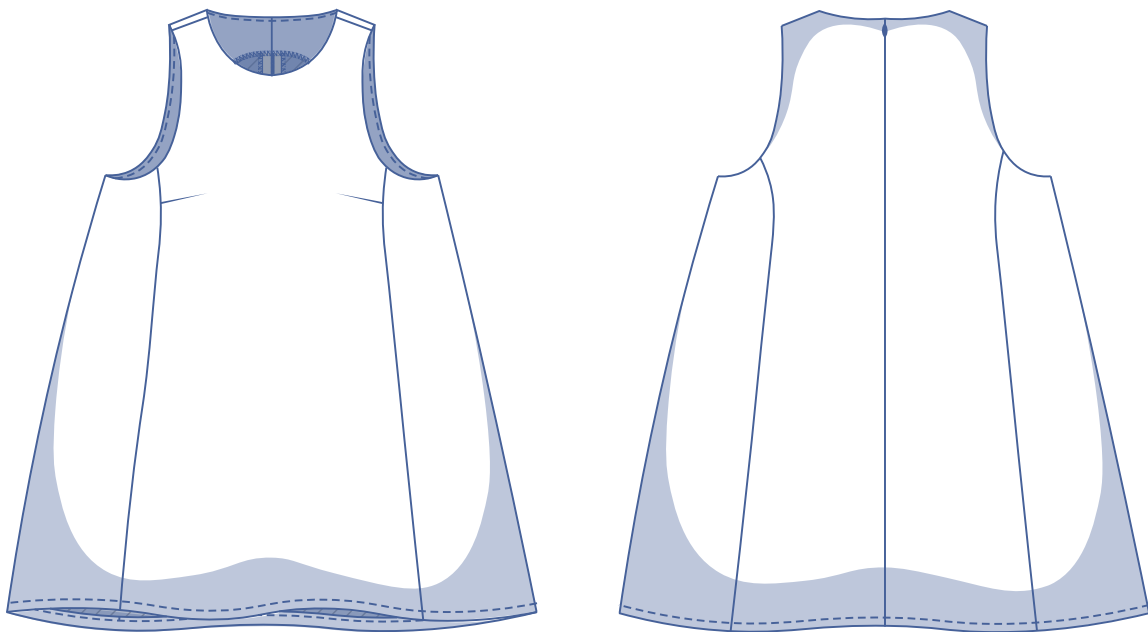

size chart (in cm)

size	4	6	8	10	12	14	16	18	20	22	24	26	28	30	32
body height	160	164	166	167	168	169	170	171	172	172	172	172	172	172	172
B (bust)	76	80	84	88	92	96	100	104	110	116	122	128	134	140	146

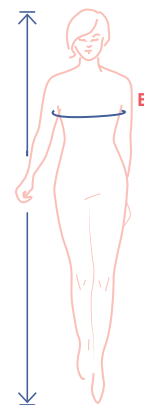

Choose your size based on the [bust measurement](#). Pick the size that is the best match for your bust.

pattern measurements (in cm)

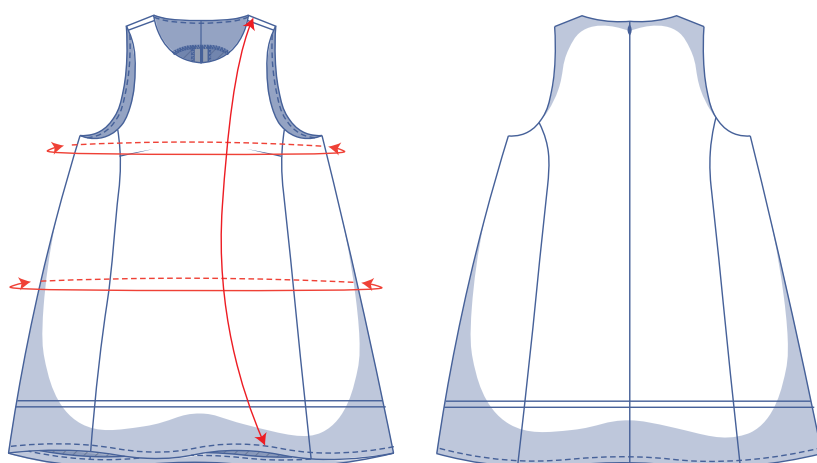

This chart's measurements are the pattern measurements based on the fabric type and serve as a reference. Ease has been added to the width measurements (in addition to the exact body measurements) for a more comfortable fit. **Petula is designed to be fitted at the bust but loose around the waist and hips).**

== shorten or lengthen the pattern here

size	4	6	8	10	12	14	16	18	20	22	24	26	28	30	32
length	84.25	84.75	85.25	85.75	86.25	87	89.5	90	93.75	94.5	95.5	96.25	97	97.75	98.5
bust	79.75	83.75	87.75	91.75	95.75	99.75	103.75	107.75	113.75	119.75	125.75	131.75	137.75	143.75	149.75
hips	138.25	142.25	146.25	149.25	152.25	155.25	158.25	161.25	167.25	172.25	177.25	182.25	187.25	192.25	197.25

Compare the stated lengths to the measured or desired lengths. **Lengthen** or **shorten** the dress by cutting the pattern pieces along the indicated double lines. Then either increase the distance between the cut pieces by the desired amount (to lengthen) or overlap the pieces (to shorten). Make sure that the CF and CB lines and the side seams are always straight.

IMPORTANT

Adjust the amount of fabric to be used based on these alterations.

notions



- Thread
- Iron-on interfacing: max. 60 cm
- Concealed zip: 40 cm
- Fabric: see table

fabric use		4	6	8	10	12	14	16	18	20	22	24	26	28	30	32
fabric width 110 cm	cm	175	185	205	220	230	235	255	265	280	285	285	320	320	325	330
fabric width 140 cm	cm	160	160	165	165	165	170	175	175	195	210	210	215	230	250	275

The corresponding fabric layout can be found on page 6 of these sewing instructions.

fabric advice



A statement Petula demands a fabric with extra body, to make the dress 'stand up' rather than 'fall down'. So choose, for example, woven jacquard, (silicone) poplin, taffeta or ottoman. Not such a fan of this voluminous effect? Then go for a supple fabric such as double gauze, chambray, lyocell or linen.





pattern pieces & seam allowances (in cm)

To sew the garment as described in the instructions, draw the illustrated seam allowances around the paper pattern pieces before cutting them out. If you are using a PDF pattern, the pattern can be printed with or without seam allowance. To find out more, watch the [video](#).

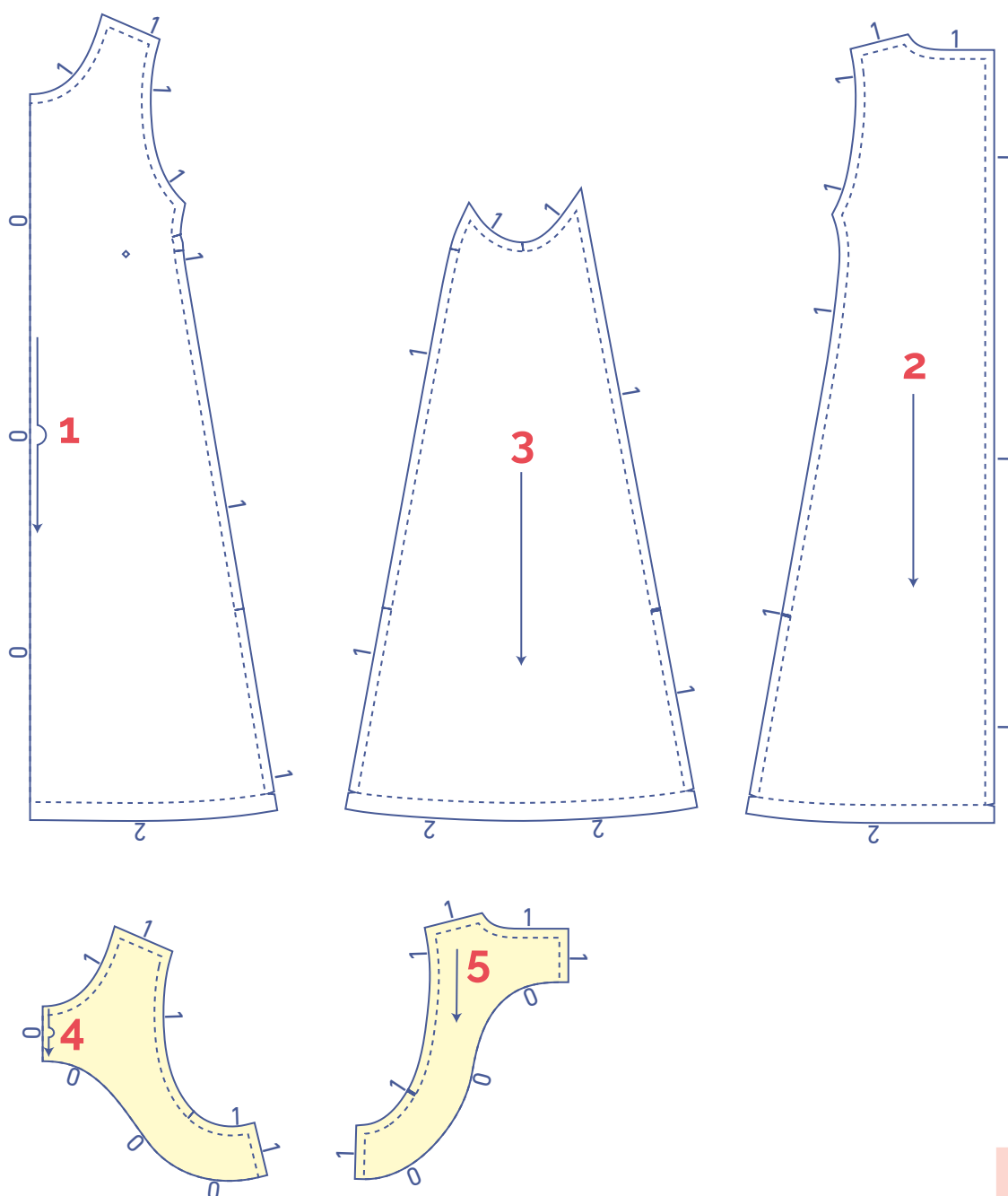
1. front: 1x on the fabric fold
2. back: 2x
3. side piece: 2x
4. facing F: 1x on the fabric fold
5. facing B: 2x



 material type
 fabric
 iron-on interfacing

fabric layout for solid fabrics
fabric width 110 cm

4 - 18

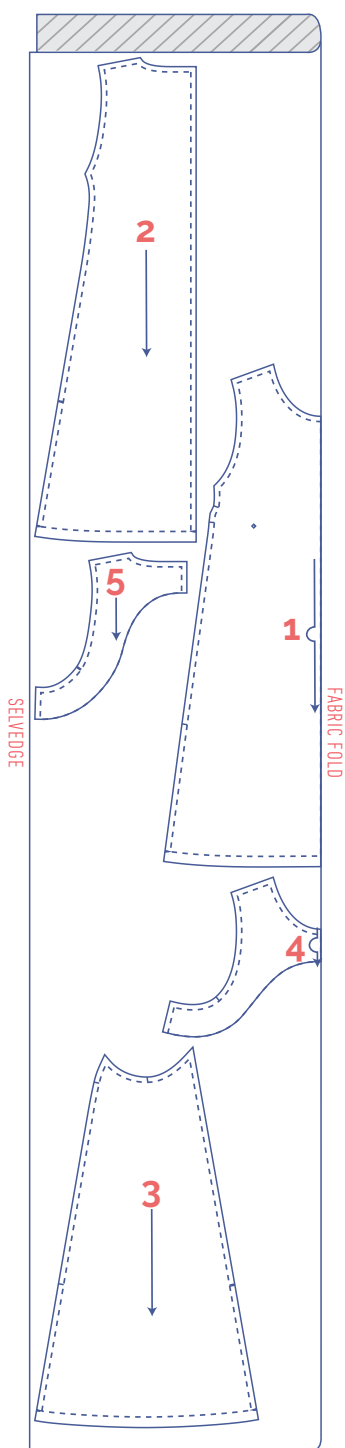

20 - 24

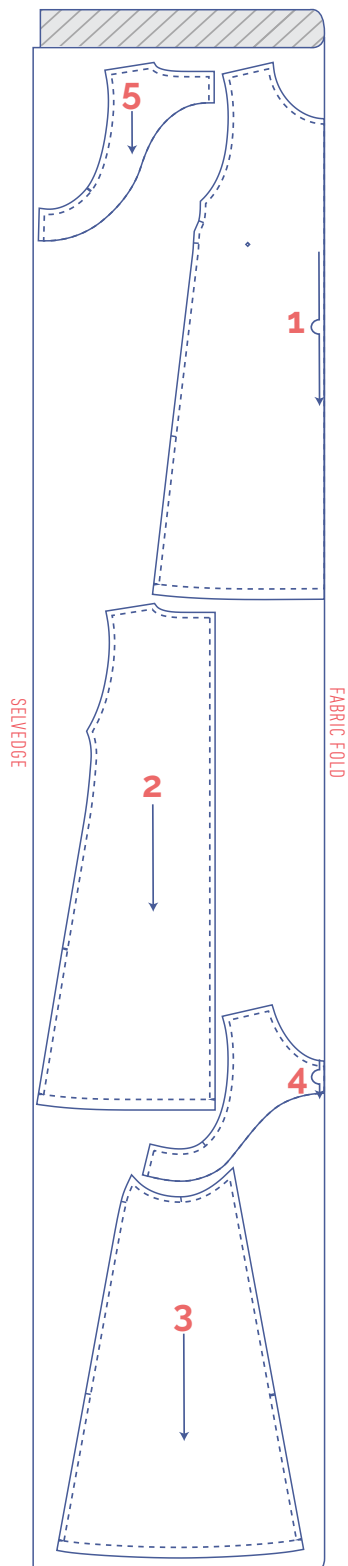

26 - 32

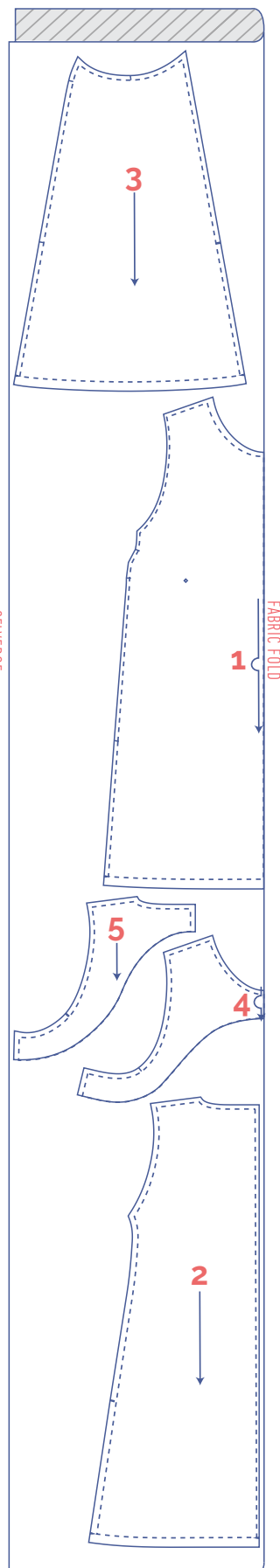



fabric layout for solid fabrics
fabric width 140 cm

4 - 20

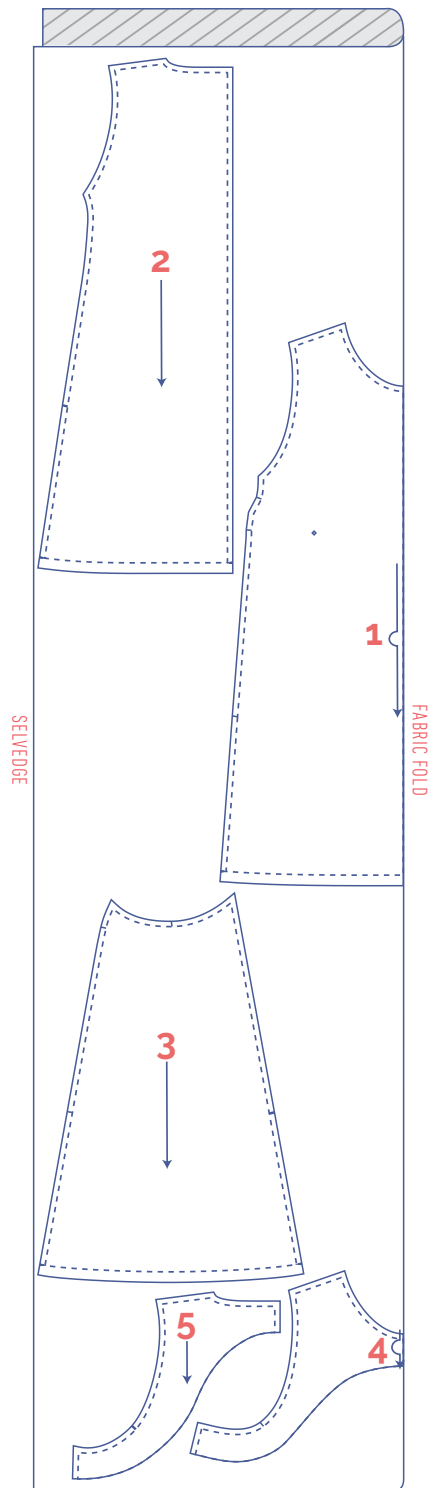
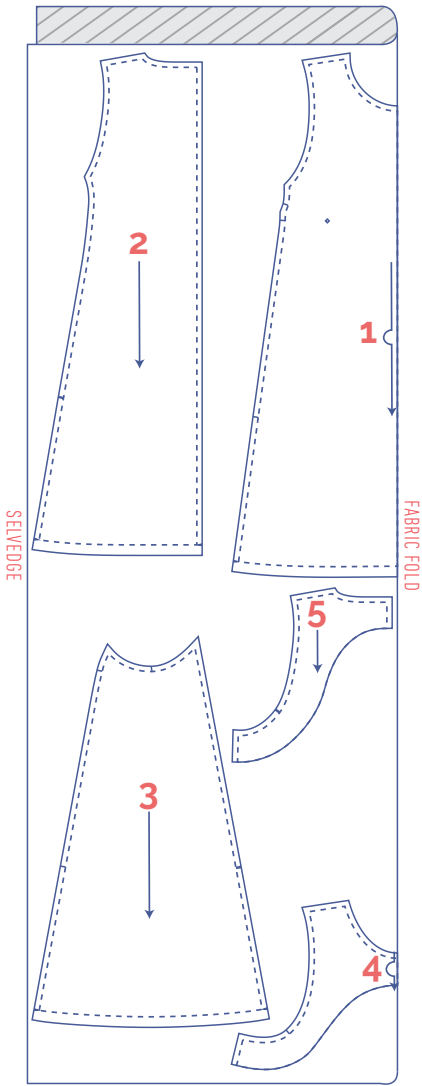
22 - 32



marking pattern pieces

	notch the paper pattern and fabric at the following points
	single notch
	double notch
∨	V notch/fabric fold
	mark with a marking thread
	centre point

sewing instructions



The method used to finish the seams depends on the fabric used. The pieces are always sewn together with the right sides of the fabric facing, unless stated otherwise.



F front

B back

SP side piece

CF centre front

CB centre back

RB right back 

LB left back 

 right side

 wrong side

 iron-on interfacing

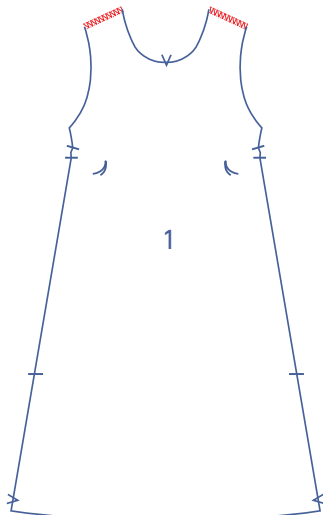
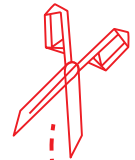

1

Finish the raw edges of the front (1) where indicated with overlock stitching.

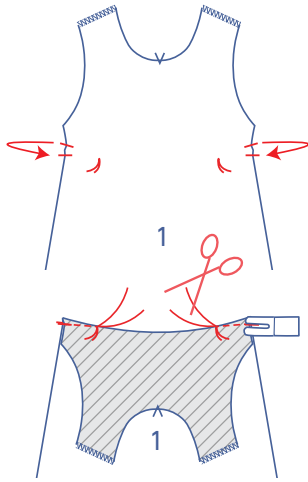

Match the marked notches together with the right sides of the fabric facing. Sew the dart in a slightly curved line towards the marking thread. Sew up to and just past the marking thread, so that you've sewn past the fabric. Snip the threads and tie a knot.

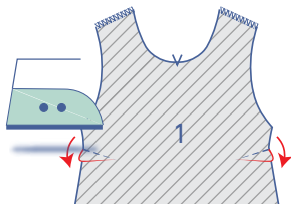

Turn over so that the wrong side is facing up. Press the dart over and down.

2

Finish the raw edges of B (2) with overlock stitching where indicated.

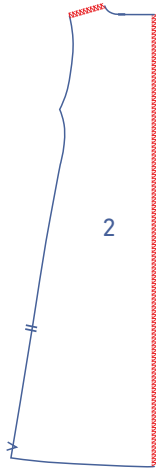

Place both pieces of B in front of you with the right sides facing up. Then place the concealed zip in front of you with the right side facing up. Open the zip.

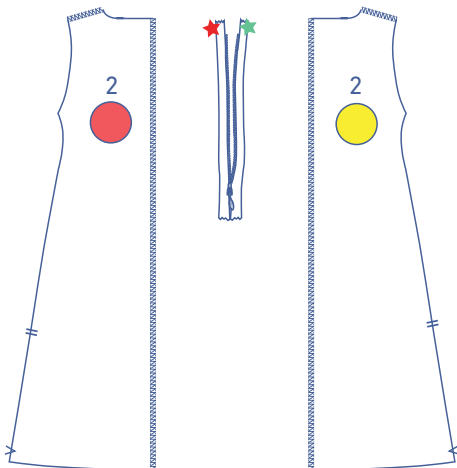

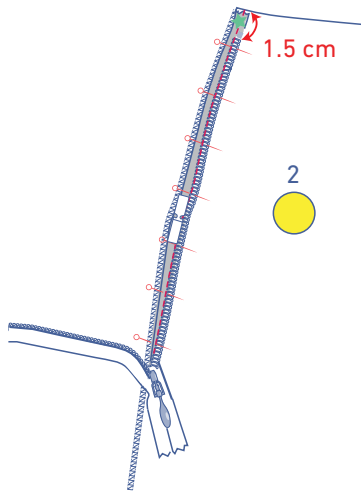

Now, fold the zip tape marked with the green star to the right and pin it to the RB with right sides together. The side of the zip tape should match the overlocked edge of the fabric. The zip teeth should start 1.5 cm under the raw edge of the neckline. Sew into place with the invisible zipper foot.

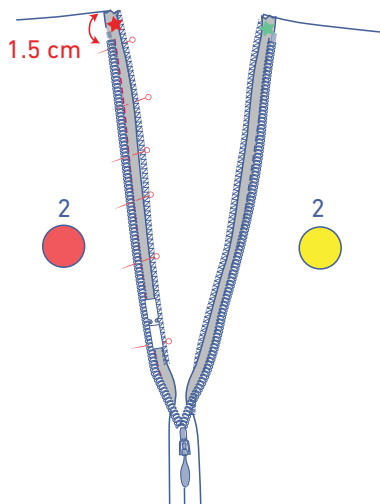

Now, fold the zip tape marked with the red star to the left and pin it to the LB with right sides together. The side of the zip tape should match the overlocked edge of the fabric. The zip teeth should start 1.5 cm under the raw edge of the neckline. Sew into place with the invisible zipper foot.

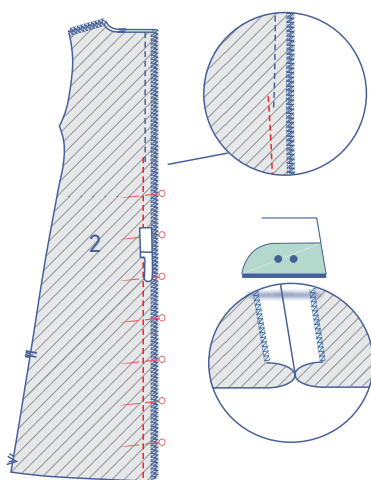

Close the zip and pin the rest of the CB seam under the zip. Sew into place with the zipper foot. Start sewing just above and next to your previous row of stitching (i.e. the stitching for the zipper). Press the seam allowance open.

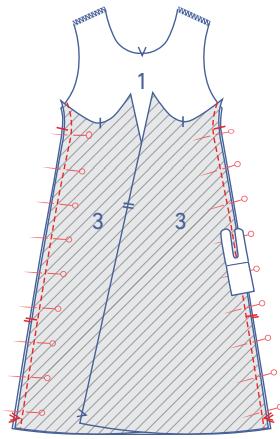

3

Pin and stitch the edge with the single notches of the SP (3) to F.

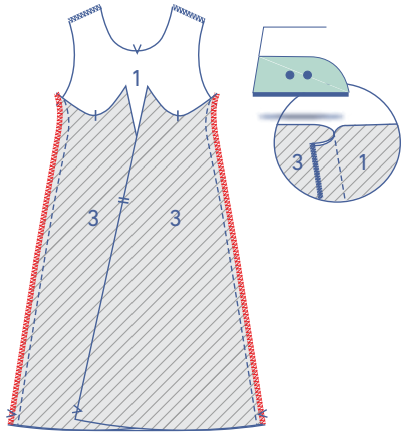

Finish the raw edges with overlock stitching. Press the seam allowance towards the SP.

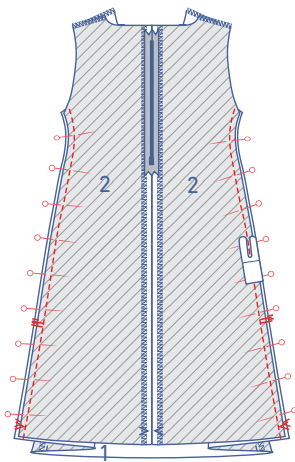

Pin and stitch the edge with the double notches of the SP to B.

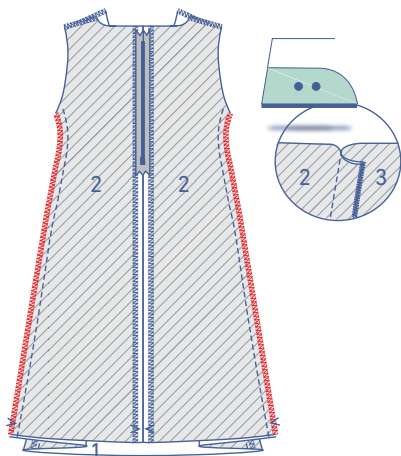

Finish the raw edges with overlock stitching. Press the seam allowance towards the SP.

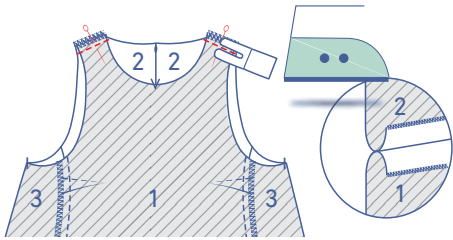

Pin and sew the shoulder seams together. Press the seam allowances open. Diagonally clip the seam allowances at the tips to prevent bunching.

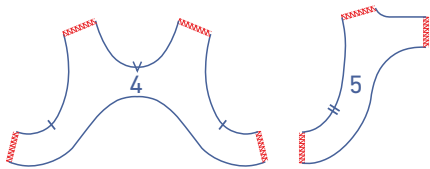
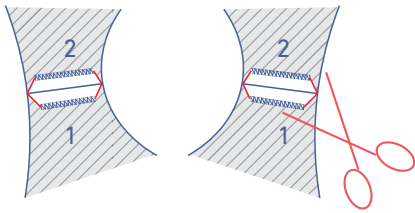

4

Finish the raw edges of the facing F (4) and facing B (5) where indicated with overlocking.

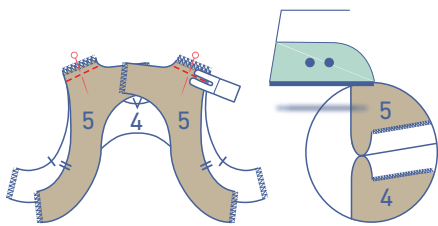

Pin and sew the shoulder seams together. Press the seam allowances open. Diagonally clip the seam allowances at the tips to prevent bunching.

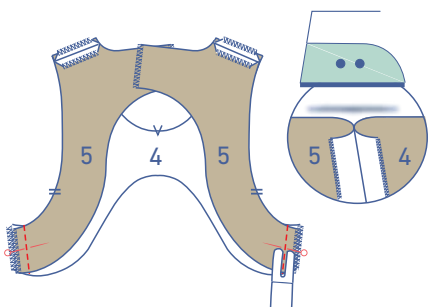
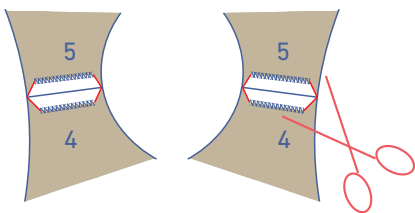

Pin and sew the side seams together. Press the seam allowances open.

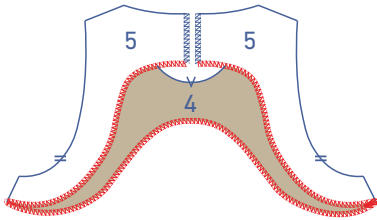

Overlock the bottom edge to finish.

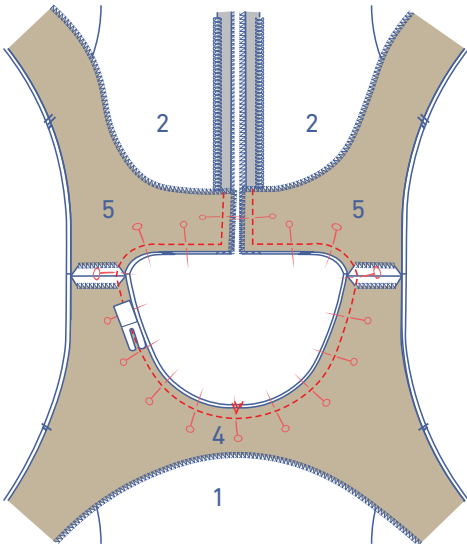

Place the facing on top of the dress, right sides together, matching the V notches and shoulder seams. Pin and stitch the neckline.

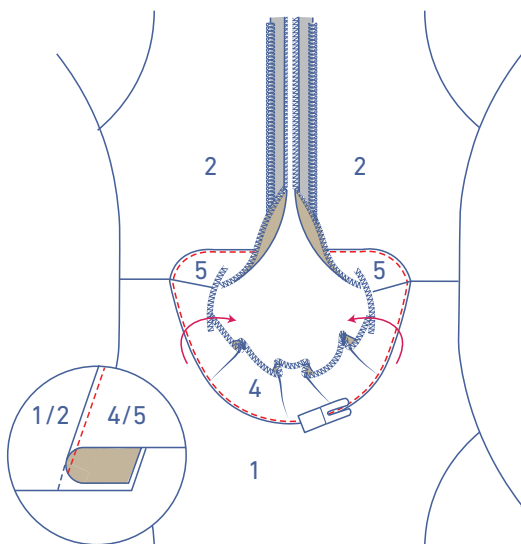

Fold the facing over and sew to the seam allowance underneath, right next to the seam. Sew as far as you can into the corners near the CB.

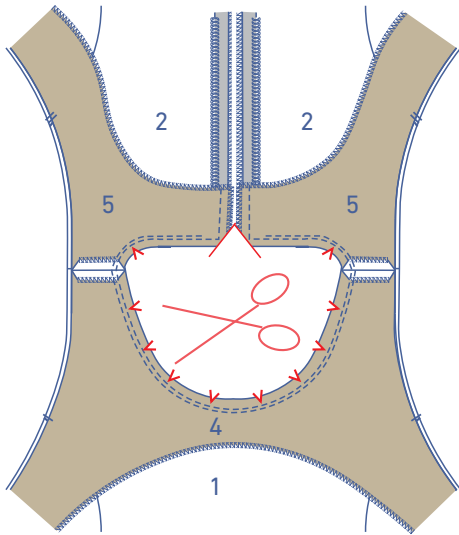

Cut triangles from the remaining seam allowance to allow the neckline to lie flat, then trim the seam allowance in the corners.

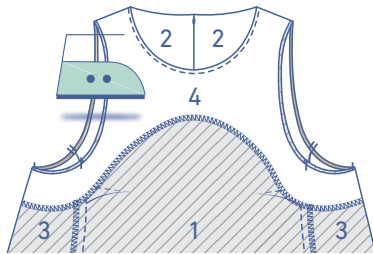

Turn out the right way and press flat.

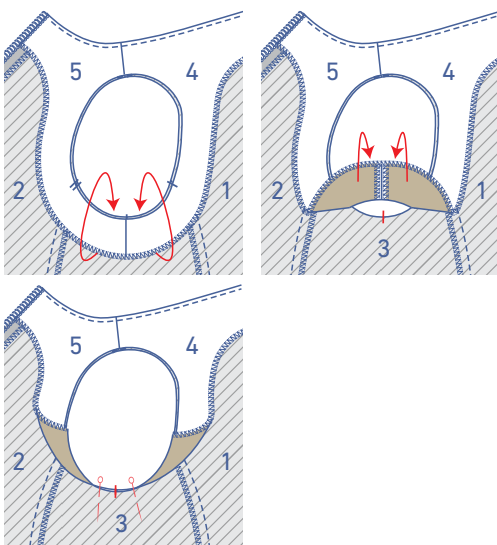
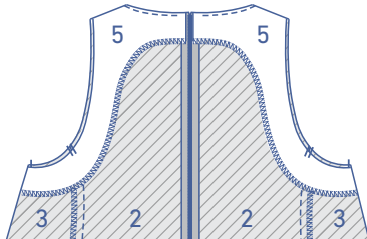

5

Position the armhole of the facing on the armhole of the dress wrong sides together. Then flip over the facing near the underarm so that the facing is right sides together with the dress, and pin.

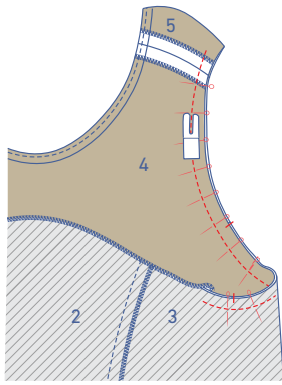

Stitch the facing armhole to the dress armhole right sides together, starting from the side seam of the facing. Do this in 2-cm increments: match the raw edges and sew approx. 2 cm. Line up the raw edges again and sew another 2-cm increment, etc. Continue until you've sewn just past the shoulder seam.

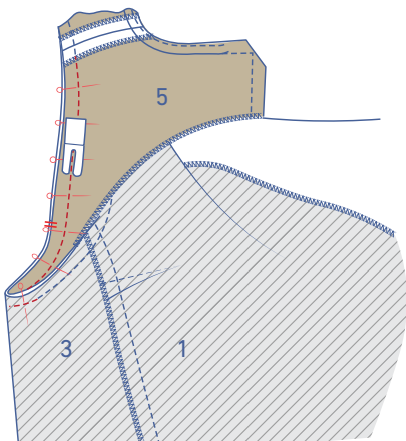

Now, match the seam allowances of the armhole of the other half, past the shoulder seam, and continue sewing from the shoulder (from where you left off) to the side seam.

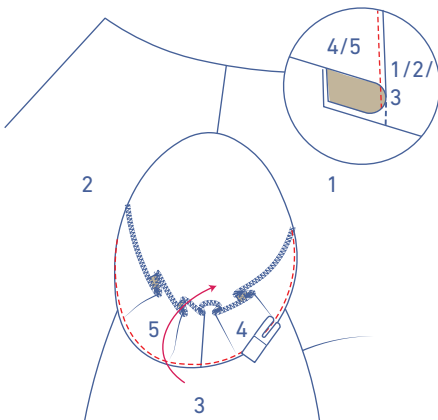

Fold the facing over/up and sew to the seam allowance underneath, right next to the seam. Sew as far as you can then start again along the other side of the armhole. This may seem like rather fiddly work, but have faith. You're on the right track as long as you follow these instructions.

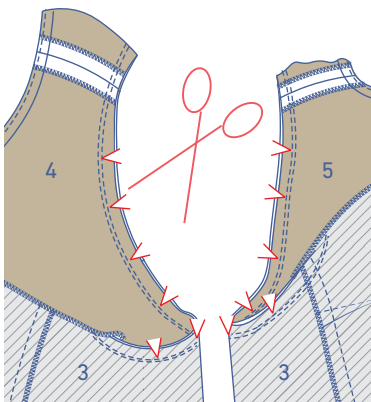

Fold the facing back so wrong sides are together and notch the armhole's remaining seam allowance in several places so the facing can lie flat and the seam doesn't tug too much.

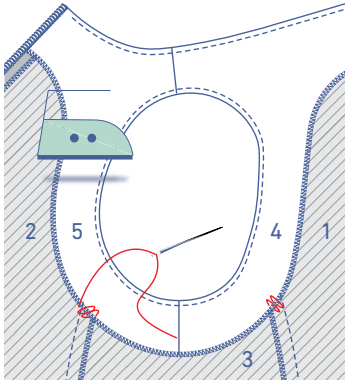

Fold the facing back to its final position and neatly press flat. Fix the facing to the seams of the dress with a few stitches.

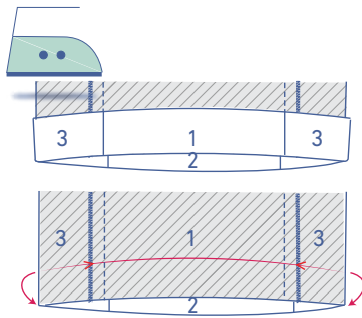

6

Press the hem allowance up and open back out.

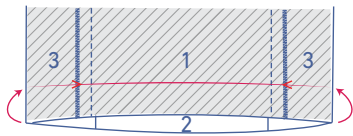

Fold the raw edge to the pressed fold line and fold over again.

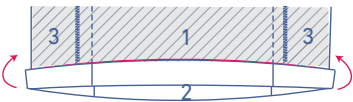

Edgestitch into place.

