



Nona by Fibre ood

# Nona by Fibre ood



0 - 28

Bellissima! This lovely top is going to give you Mediterranean holiday vibes for sure, with its V neck front and back. The flounce is attached to the lining, creating a playful balloon effect. The zip is neatly concealed in the left side seam. We think this top looks most beautiful cropped at waist level. Would you rather make it longer? Then take care to widen the hem from the waist point.

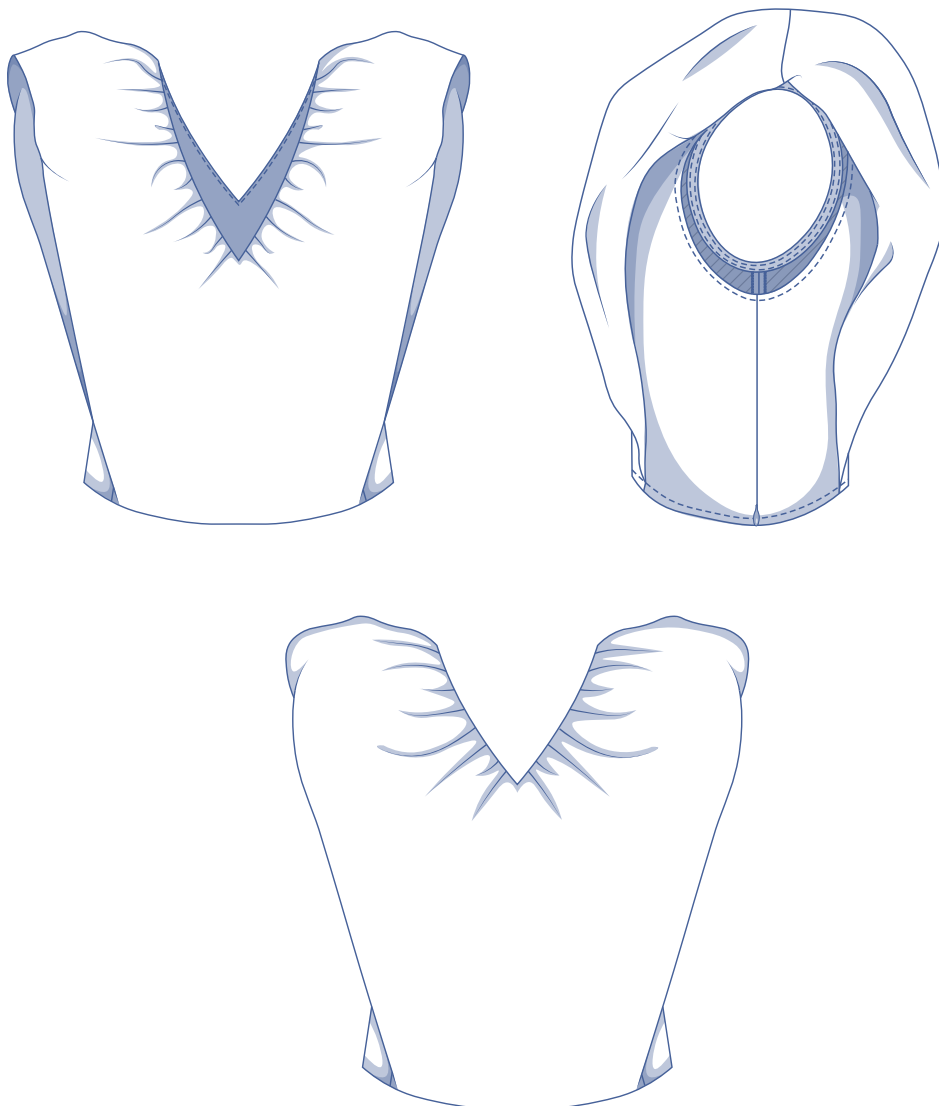

## size chart (in inches)

size	0	2	4	6	8	10	12	14	16	18	20	22	24	26	28
body height	5' 25"	5' 38"	5' 45"	5' 48"	5' 51"	5' 54"	5' 58"	5' 61"	5' 64"	5' 64"	5' 64"	5' 64"	5' 64"	5' 64"	5' 64"
B (bust)	29.9	31.5	33.1	34.6	36.2	37.8	39.4	40.9	43.3	45.7	48	50.4	52.8	55.1	57.5

Choose your size based on the [bust measurement](#). Pick the size that is the best match for your bust. Then, check the waist and hem measurements in the table below to be sure there is sufficient room at the waist and hem.

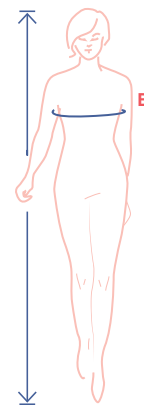

## pattern measurements (in inches)

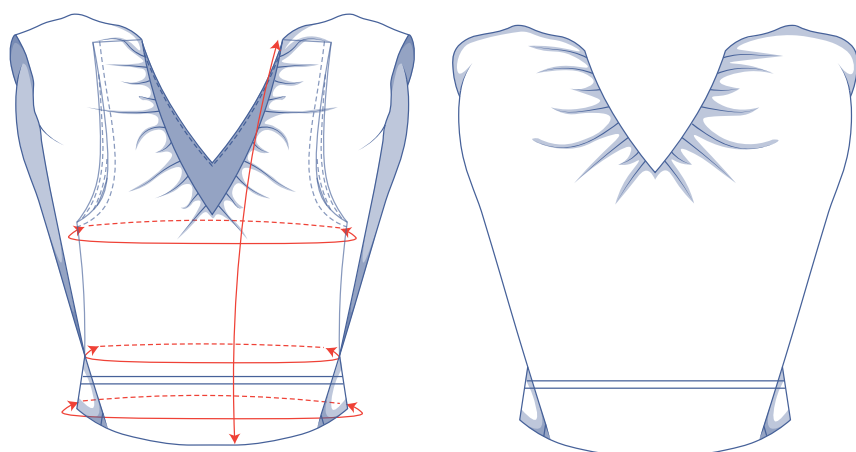

== shorten or lengthen the pattern here

This chart's measurements are the pattern measurements based on the fabric type and serve as a reference. Ease has been added to the width measurements (in addition to the exact body measurements) for a more comfortable fit. [Nona is designed to have a fitted cut.](#)

size	0	2	4	6	8	10	12	14	16	18	20	22	24	26	28
length	18.5	19	19.25	19.5	19.75	20	20.5	20.75	21.75	22	22.5	22.75	23.25	23.75	24
bust*	32.25	33.75	35.5	37	38.5	40.25	41.75	43.25	45.75	48	50.25	52.75	55	57.5	59.75
waist*	28.75	29.5	30.25	32	33.5	35	35.75	37.5	40	42.5	45	47.75	50.25	52.75	55.25
hem circumference	32	32.75	33.5	35	36.75	38.25	39	40.75	43.25	45.75	48.25	50.75	53.5	56	58.5

\* These circumferences are measured on the lining.

Compare the stated lengths to the measured or desired lengths. [Lengthen](#) or [shorten](#) the top by cutting the pattern pieces at the indicated double lines. Then either increase the distance between the cut pieces by the desired amount (to lengthen), or overlap the pieces (to shorten). Make sure that the CF and CB lines and the side seams are always straight.

### IMPORTANT

Adjust the amount of fabric to be used based on these alterations.

## notions



- Thread
- Concealed zip: 9"
- Fabric: see table

fabric use		0	2	4	6	8	10	12	14	16	18	20	22	24	26	28
fabric width 43"	yd	2 ¼	2 ¼	2 ½	2 ½	2 ½	2 ½	2 ½	2 ¾	2 ¾	3 ¼	3 ¼	3 ½	3 ½	3 ½	3 ½
fabric width 55"	yd	2	2	2	2	2	2	2	2	2 ¾	2 ¾	2 ¾	2 ¾	3	3	3

The corresponding fabric layout can be found on page 6 of these sewing instructions.

## fabric advice



Nona becomes a real eye-catcher in a stiffer fabric like poplin, batiste or organza. Chambray, double gauze, lyocell or linen will also give extra volume. If you would like the playful top to be supple, choose a lighter fabric like (viscose) crêpe.

**HAPPINESS**  
*is a*  
**FULL BOBBIN**



## pattern pieces & seam allowances (in inches)

To sew the garment as described in the instructions, draw the illustrated seam allowances around the paper pattern pieces before cutting them out. If you are using a PDF pattern, the pattern can be printed with or without seam allowance. To find out more, watch the [video](#).

1. front: 1x on the fabric fold
2. lining F: 1x on fabric fold
3. F side: 2x
4. back: 1x on the fabric fold
5. lining B: 1x on fabric fold
6. B side: 2x
7. bias tape: 2x

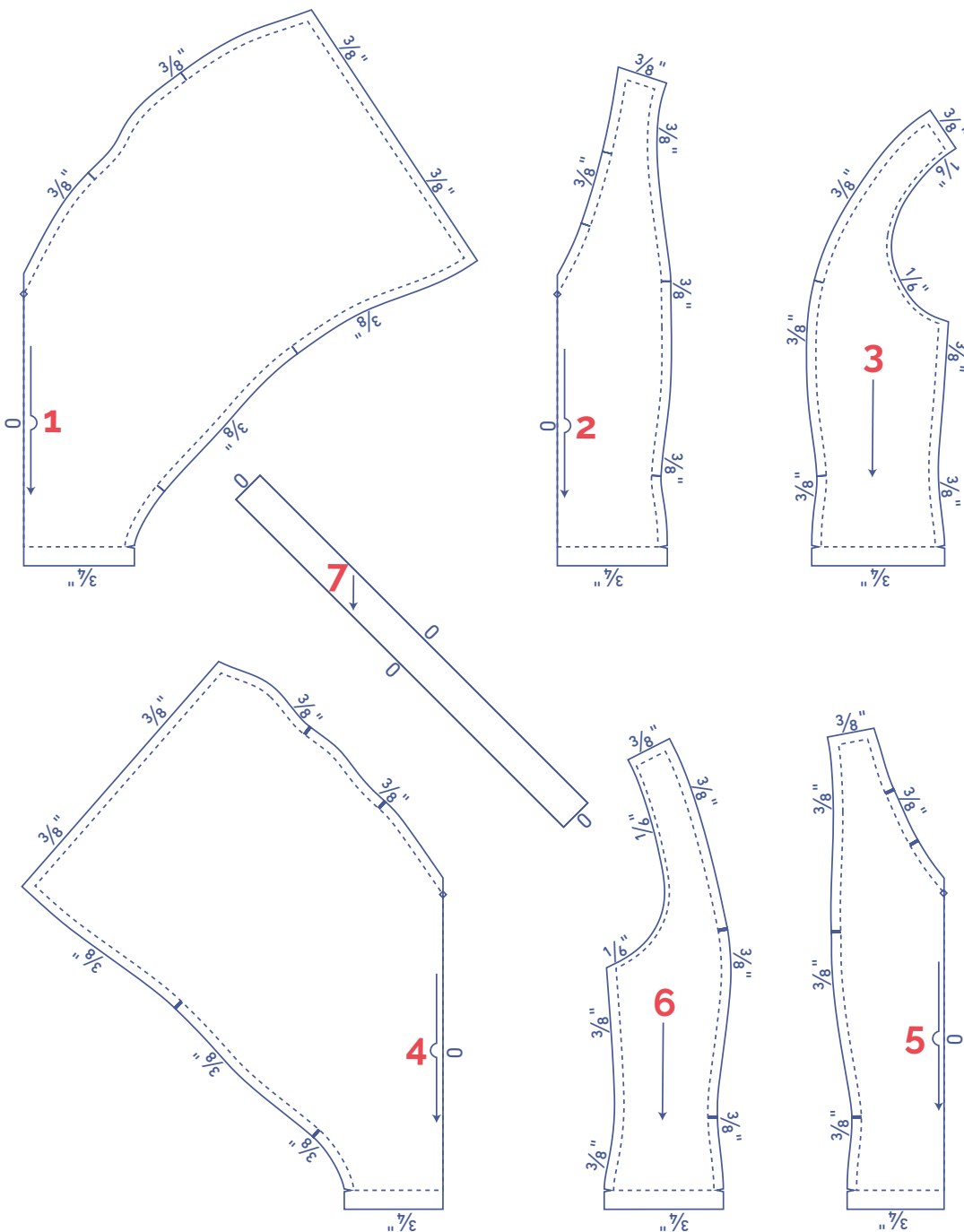

# fabric layout for solid fabrics fabric width 43"

0 - 16

18 - 28

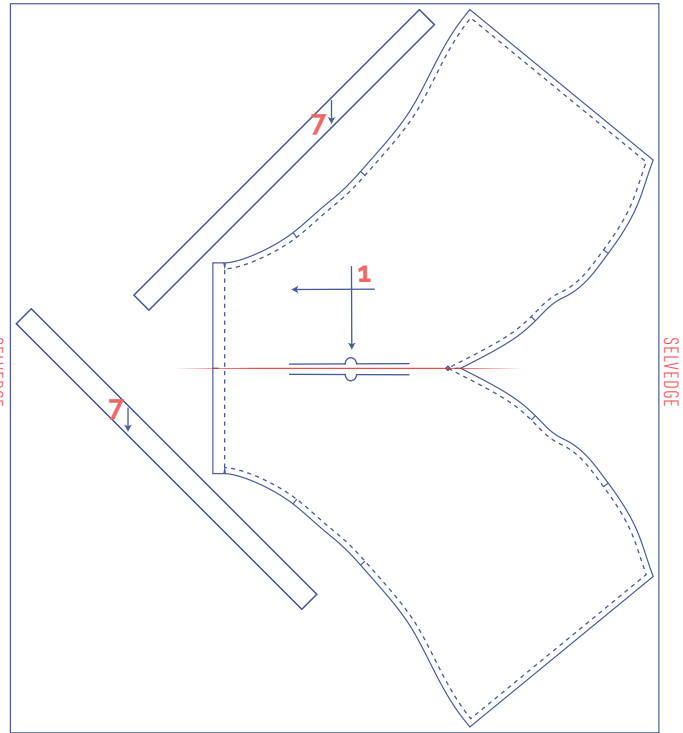
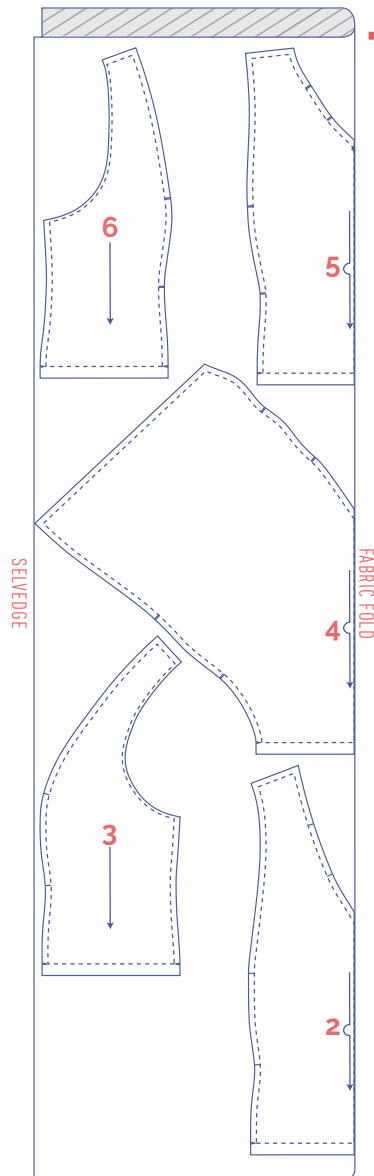
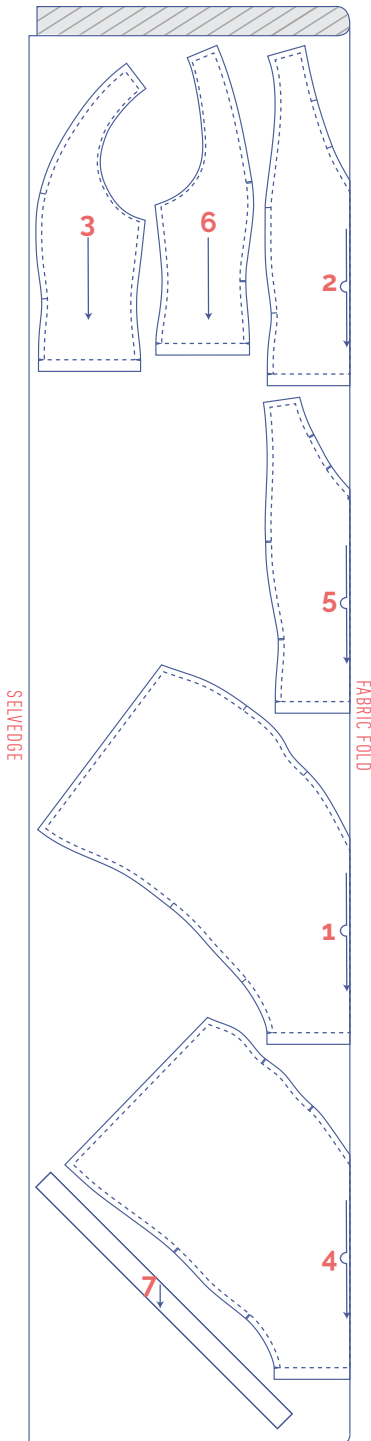

### Important!

Pattern piece 1 has been rotated at a 90° angle to fit the fabric width. Be aware of this if you are using patterned or napped fabric.

## marking pattern pieces



notch the paper pattern and fabric at the following points



single notch



double notch



V notch/fabric fold



mark with a marking thread



centre point

# fabric layout for solid fabrics fabric width 55"



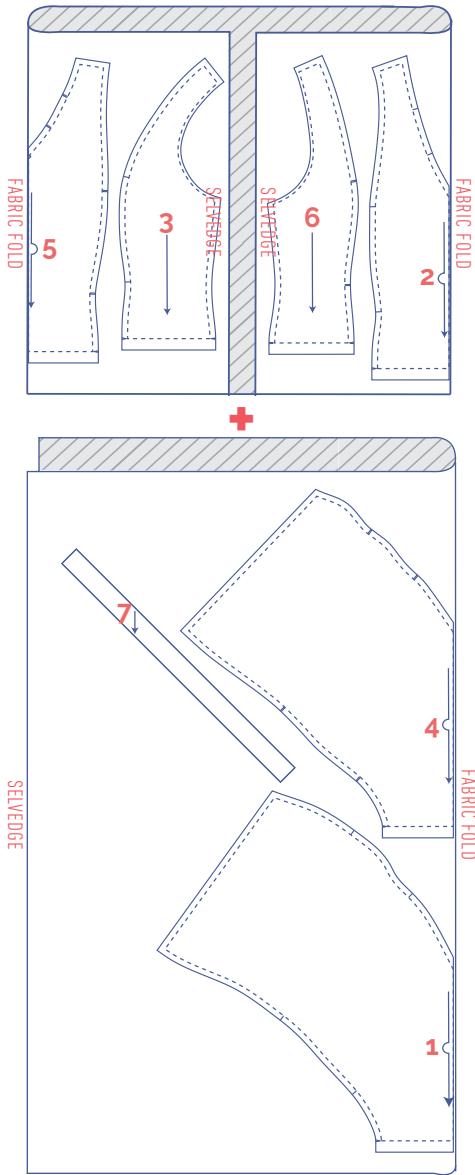

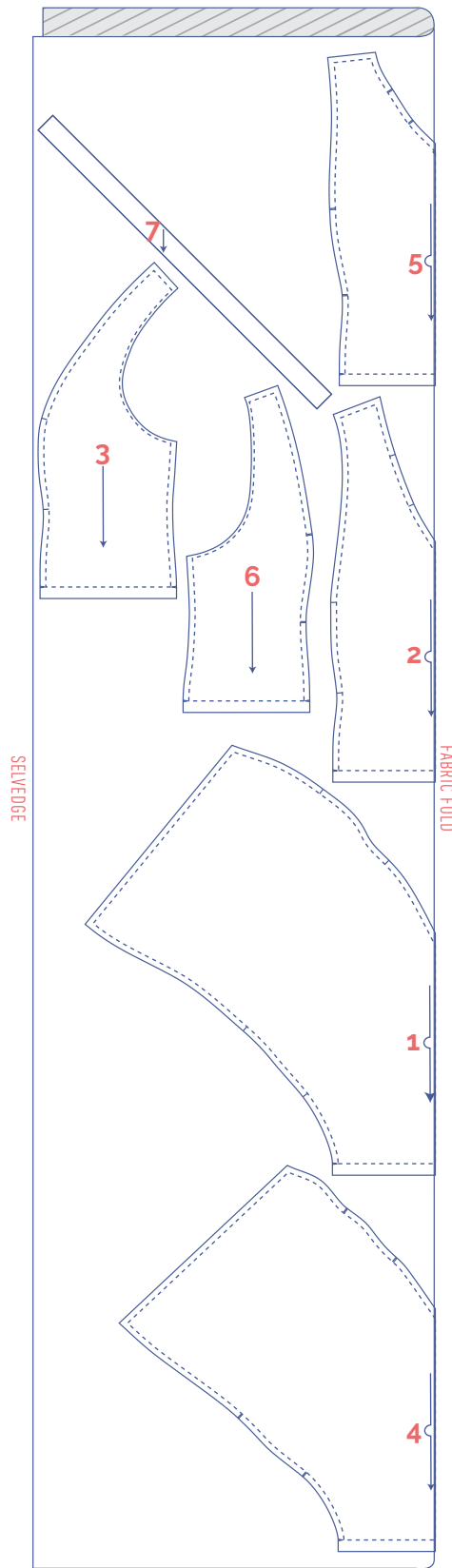

0 - 14



16 - 28



## marking pattern pieces







	notch the paper pattern and fabric at the following points
	single notch
	double notch
	V notch/fabric fold
	mark with a marking thread
	centre point

# sewing instructions



The method used to finish the seams depends on the fabric used. The pieces are always sewn together with the right sides of the fabric facing, unless stated otherwise.



<b>F</b>	front
<b>B</b>	back
<b>CF</b>	centre front
<b>CB</b>	centre back
<b>RF</b>	right front 
<b>LF</b>	left front 
<b>RB</b>	right back 
<b>LB</b>	left back 
	right side
	wrong side

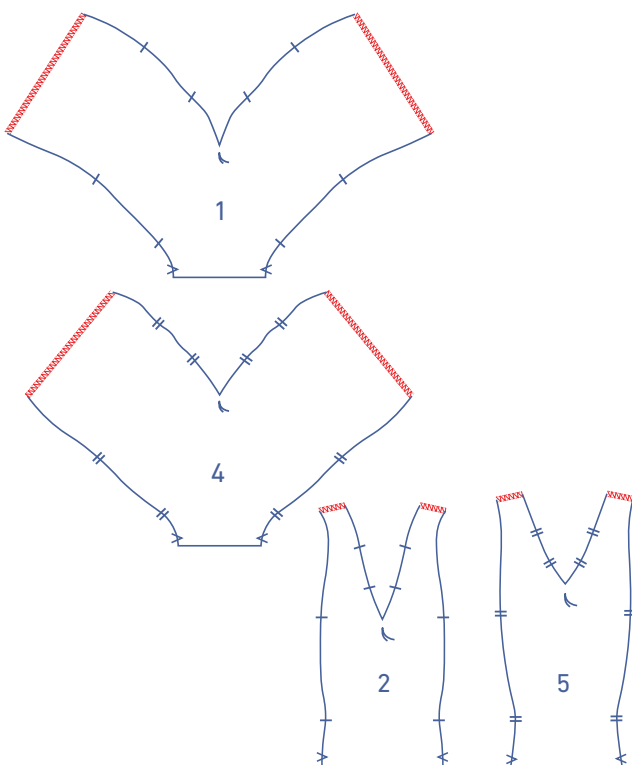
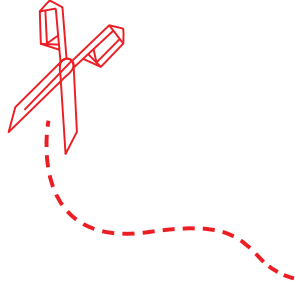

## 1

Finish the raw edges of the pieces F (1), B (4), F lining (2) and B lining (5) with overlock stitching where indicated.



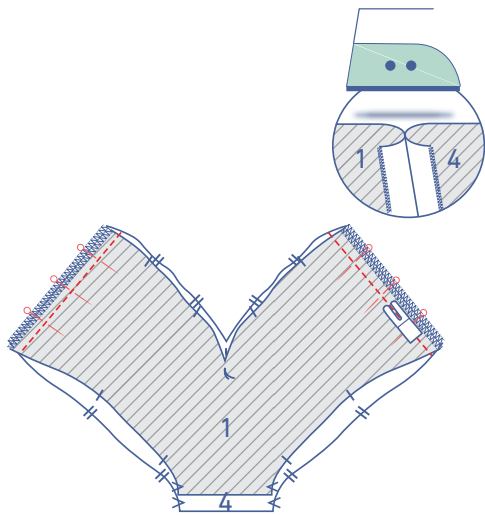

Pin and sew the shoulder seams of the front and back. Press the seam allowances open.

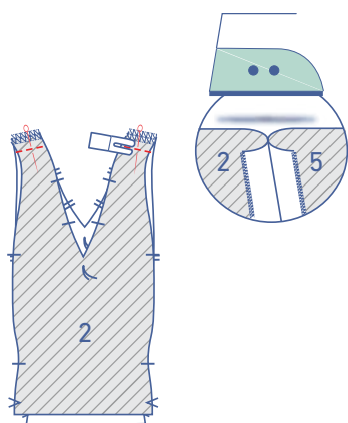

Pin and sew the shoulder seams of the pieces lining F and lining B. Press the seam allowances open.

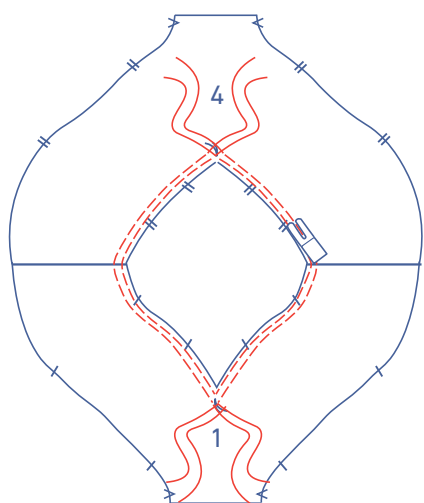

Use a long stitch length and low thread tension to sew two parallel lines of stitching on the neckline of both F and B. Leave a length of thread at the start and end of your stitching.

Gently tug the ends of the threads to gather the fabric.

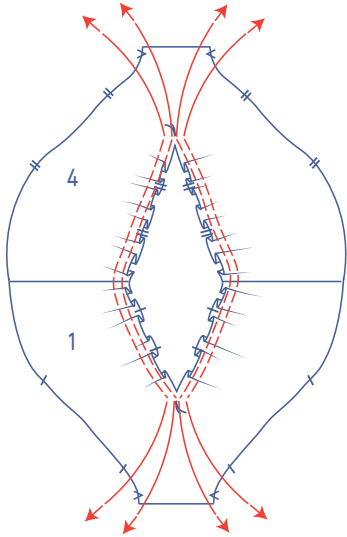

Pin the neckline of both pieces right sides together, aligning the marking threads, and distributing the gathers until the markings match.

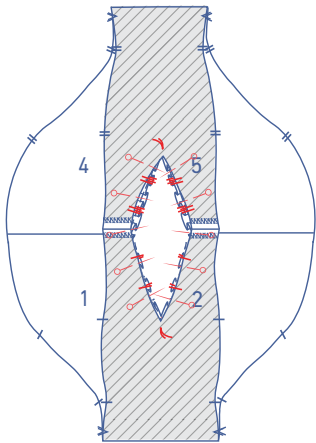
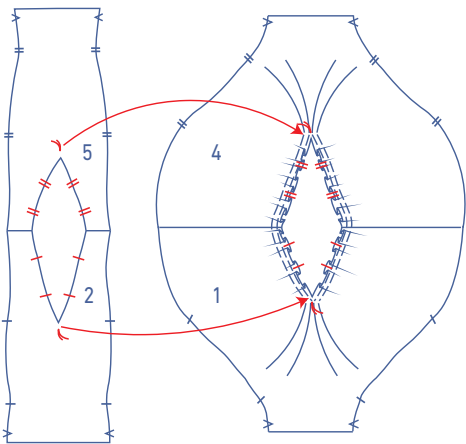

Stitch around the neckline.

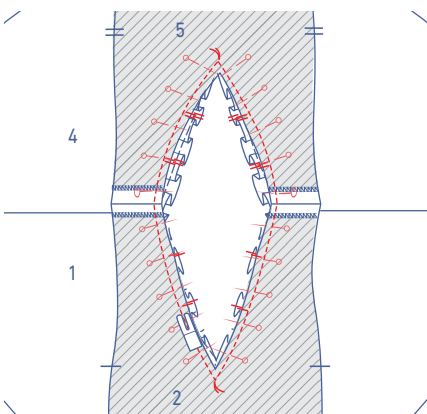

Remove the gathering threads.

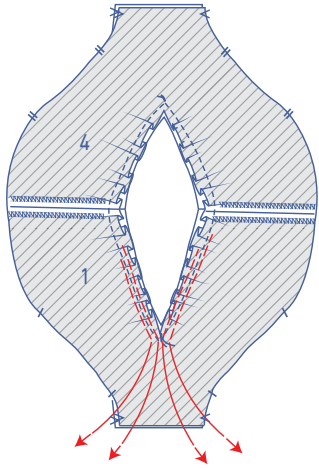

Snip into the seam allowance at the centre point of each V until just before the marking threads.

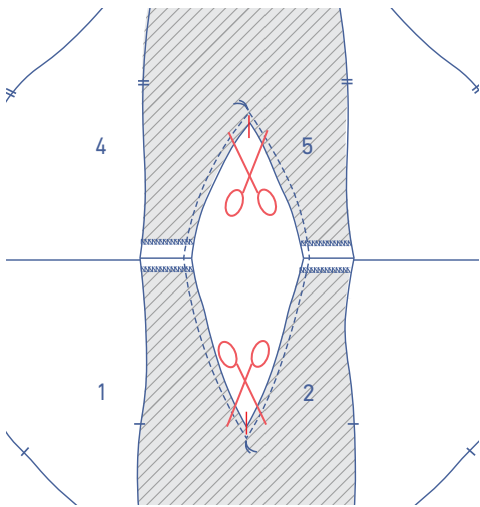

Fold the lining over and stitch it to the seam allowance underneath, right next to the seam.

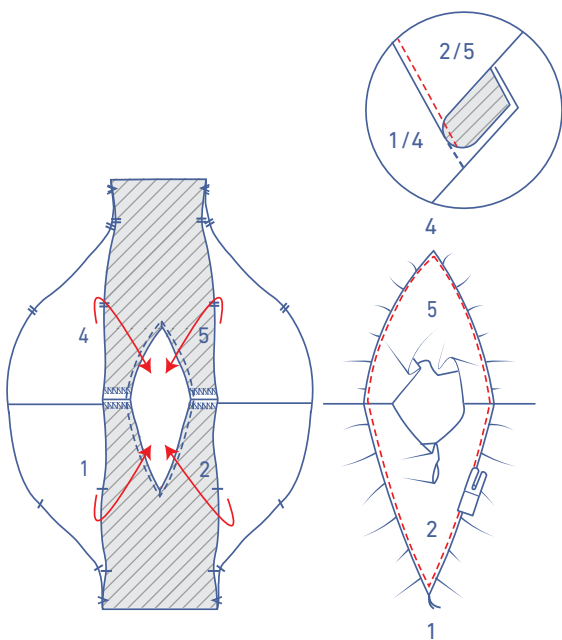

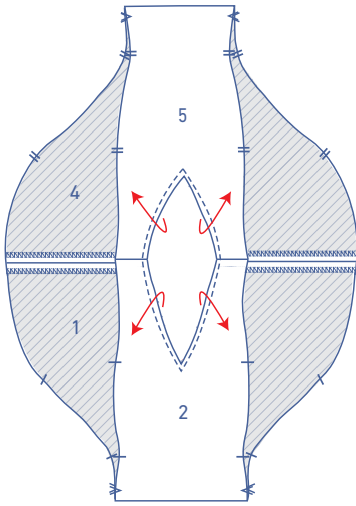

Turn the lining the right side out.

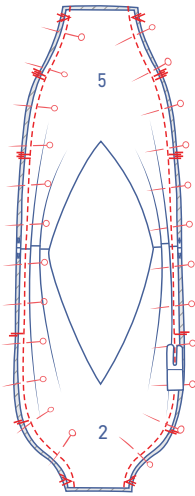

Pin the outer edges of the F and B to the lining, wrong sides together and matching notches. Sew into place at presser foot width from the edge.

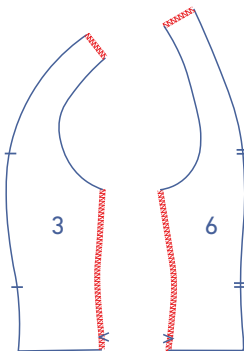

## 2

Finish the raw edges of the F (3) and B (6) side pieces where indicated with overlock stitching.

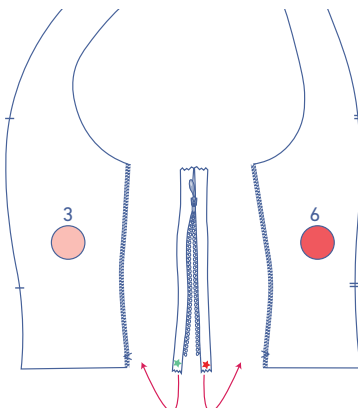

Place the LF and LB side pieces in front of you with the right sides facing up. Then place the concealed zip in front of you with the right side facing up. Open the zip. (Note the direction of the zip pull in the diagram!)

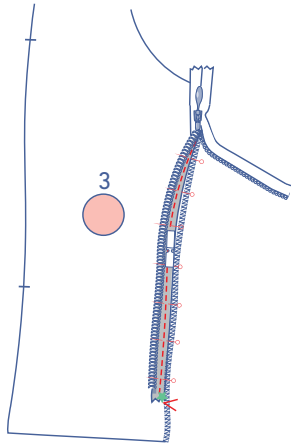

Now, fold the zip tape marked with the green star to the left and pin it to the overlocked edge of the LF. The zip tape should match the edge of the fabric, and the end of the zip lines up with the V notch marking the finished hem. Sew into place with the invisible zipper foot.

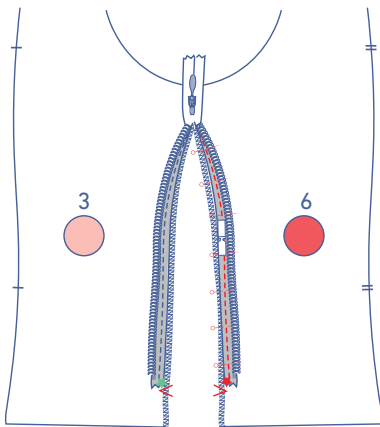

Now, fold the zip tape marked with the red star to the right and pin it to the overlocked edge of the LB. The zip tape should match the edge of the fabric, and the end of the zip lines up with the V notch marking the finished hem. Sew into place with the invisible zipper foot.

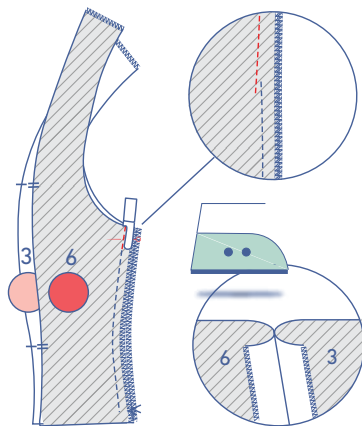

Close the zip and sew the rest of the side seam into place above the zip with the zipper foot, sewing slightly past where the stitching for the zip begins. Press the seam allowance open.

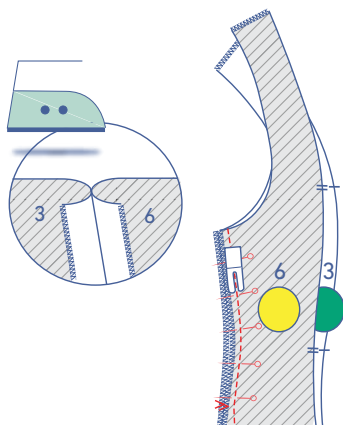

Pin and sew the other side seam into place. Press the seam allowance open.

Pin and sew the shoulder seams together. Press the seam allowances open.

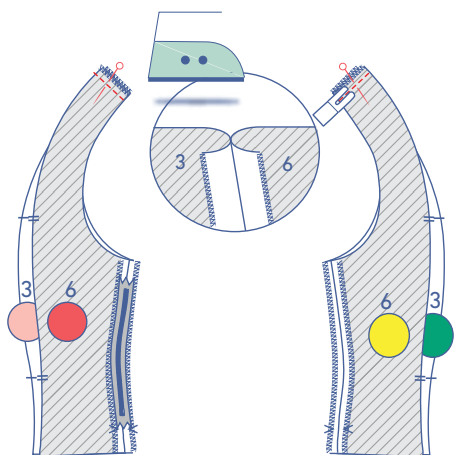

### 3

Press one short end of the bias tape (7)  $\frac{3}{8}$ " towards the wrong side. We've marked this pressed end with an orange circle. The unpressed short end has been marked with a blue circle.

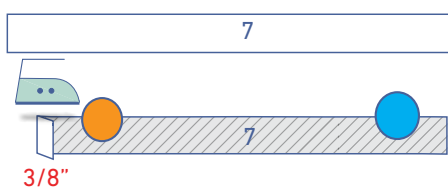

Press the bias tape in half with the long ends touching and the wrong sides of the bias tape facing each other.

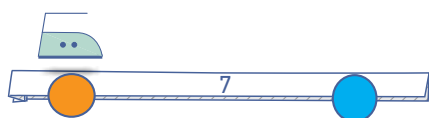

Pin raw edges of the bias tape to the armhole along the right side of the garment. The folded end should match the side seam.

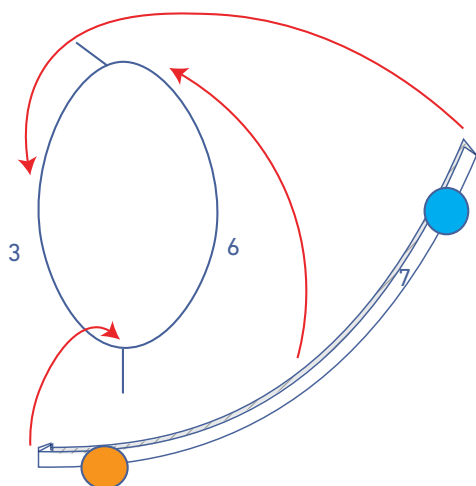

Place the unfolded end of the bias tape on top of the folded end. Trim away any excess bias tape.

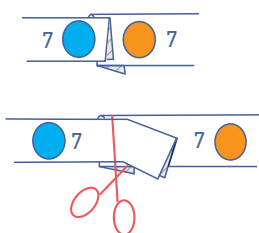

Sew into place at 1/6" from the raw edge.

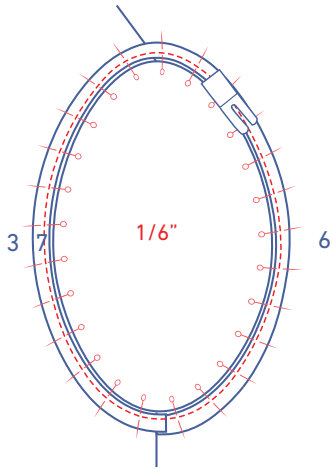

Fold the bias tape over and sew to the seam allowance underneath, right next to the seam.

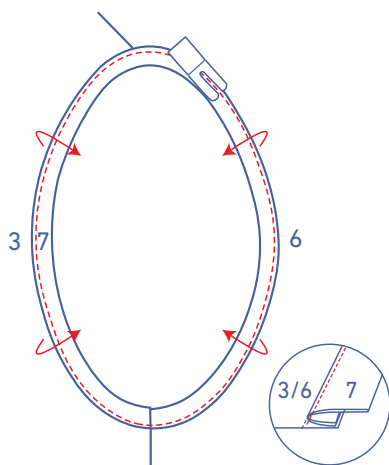

Now fold the bias tape all the way over to the wrong side and sew it into place right next to the edge.

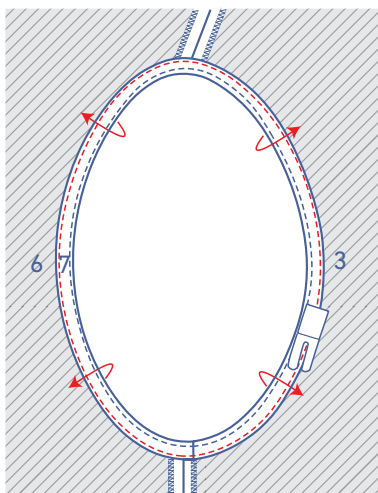

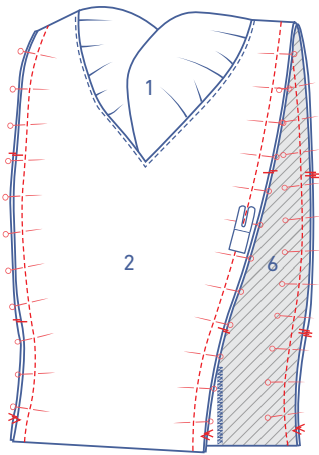

## 4

Pin the side pieces to the garment, matching the markings, and sew. The right side of the side piece is facing the right side of F + B.

Finish the raw edges with overlock stitching. Press the seam allowance towards the side piece.

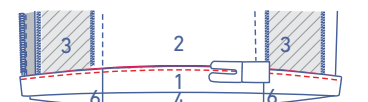
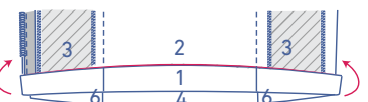
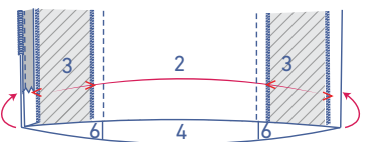
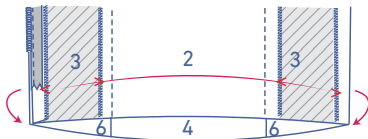
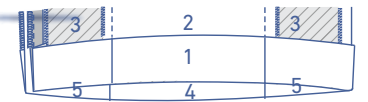
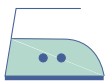
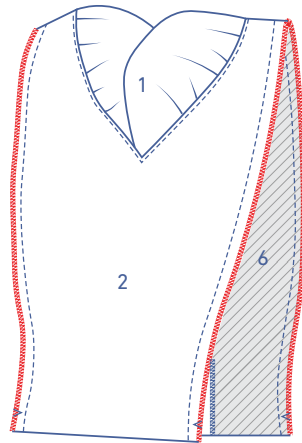
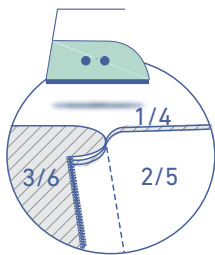

## 5

Press the hem allowance up and open back out.

Fold the raw edge to the pressed fold line and fold over again.

Edgestitch into place.