



Lucille by Fibre  Food

Lucille by Fibre ood



0 - 28

Look at Lucille, and you're likely to recognise hints of the [Tanita](#) top, [Willa](#) dress, and [Kamille](#) dress. This dress accentuates your waist with ties that can be tied at the front or back. Knot it to show off just a shade of midriff. Other features include the dolman sleeves finished with elastic and a flared panel skirt for an elegant, beautiful drape. Oh, before we forget! There's also a concealed zip down the back. In short, Lucille is elegant, beautiful, and festive.

And- that's a wrap!



size chart (in inches)

size	0	2	4	6	8	10	12	14	16	18	20	22	24	26	28
body height	5' 25"	5' 38"	5' 45"	5' 48"	5' 51"	5' 54"	5' 58"	5' 61"	5' 64"	5' 64"	5' 64"	5' 64"	5' 64"	5' 64"	5' 64"
B (bust)	29.9	31.5	33.1	34.6	36.2	37.8	39.4	40.9	43.3	45.7	48	50.4	52.8	55.1	57.5
W (waist)	26	26.8	27.6	29.1	30.7	32.3	33.1	34.6	37.2	39.8	42.3	44.9	47.4	50	52.6
H (hips)	33.9	35.4	37	38.2	39.4	40.6	41.7	42.9	45.3	47.2	49.2	51.2	53.1	55.1	57.1

Select a size based on your **waistline measurement**. Pick the size that's the best match for your waistline.

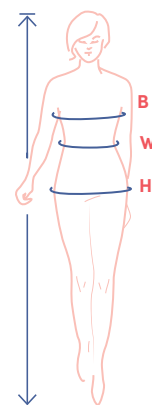

pattern measurements (in inches)

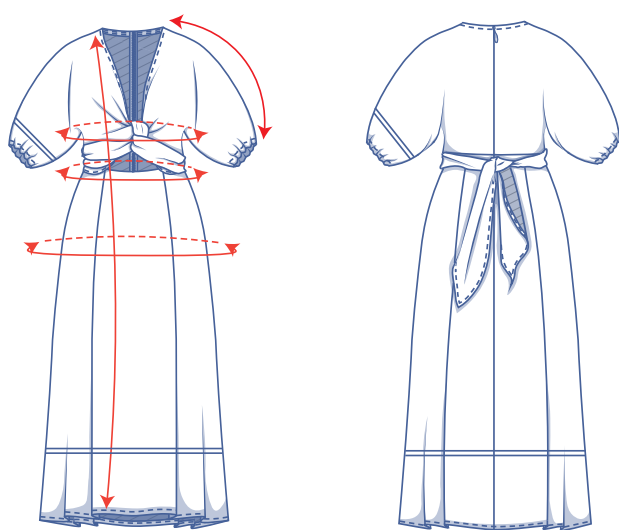

— shorten or lengthen the pattern here

This chart's measurements are the pattern measurements based on the fabric type and serve as a reference. Ease has been added to the width measurements (on top of the exact body measurements) for a more comfortable fit. Lucille is designed to be **fitted at the waist and relaxed at the bust and hips**.

size	0	2	4	6	8	10	12	14	16	18	20	22	24	26	28
length	49	49.2	49.4	49.7	49.9	50.1	50.3	50.6	51.3	51.6	52	52.3	52.6	53	53.3
sleeve length	18.4	18.7	19	19.2	19.5	19.8	20	20.3	20.9	21.3	21.8	22.3	22.7	23.2	23.6
bust	28	29.7	31.5	33.2	35	36.7	38.5	40.2	43.4	45.9	48.4	51	53.5	56	58.6
waistline*	24.6	25.4	26.2	27.7	29.3	30.9	31.7	33.3	35.8	38.4	40.9	43.5	46	48.6	51.2
hips	40	41.6	43.2	44.3	45.5	46.7	47.9	49.1	51.4	53.4	55.4	57.3	59.3	61.3	63.2

* To create an attractive fitted cut, the waist measurement is smaller than the waist measurement listed in the size chart.

Compare the stated lengths to the measured or desired lengths. **Lengthen** or **shorten** the dress and/or the sleeves by cutting the pattern pieces at the indicated double lines. Then either increase the distance between the cut pieces by the desired amount (to lengthen) or overlap the pieces (to shorten). Make sure that the CF and CB lines and the side seams are always straight.

IMPORTANT

Adjust the amount of fabric to be used based on these alterations.

notions



- Thread
- Iron-on interfacing: max. 1/5 yd
- Elastic (width 3/8"): see table (optional)
- Snap fastener (Ø 1/6"): 1
- Concealed zip: 24"
- Fabric: see table

elastic		0	2	4	6	8	10	12	14	16	18	20	22	24	26	28
length per sleeve hem	yd	0.30	0.30	0.31	0.31	0.32	0.32	0.33	0.33	0.34	0.35	0.36	0.37	0.37	0.38	0.39
total length	yd	0.59	0.60	0.61	0.62	0.63	0.65	0.66	0.67	0.68	0.70	0.72	0.73	0.75	0.77	0.78

fabric use		0	2	4	6	8	10	12	14	16	18	20	22	24	26	28
fabric width 43"	yd	4 1/4	4 1/4	4 1/2	4 1/2	4 3/4	5	5	5 1/4	5 1/2	5 3/4	5 3/4	6	6	6	6 1/4
fabric width 55"	yd	3 1/2	3 1/2	3 1/2	3 3/4	3 3/4	3 3/4	3 3/4	3 3/4	3 3/4	4	4 1/4	4 1/4	4 1/2	4 1/2	4 3/4

The corresponding fabric layout can be found on page 6 of these sewing instructions.

fabric advice



When selecting a fabric for Lucille, you're spoilt for choice. Wovens work best - lyocell, poplin, chambray, linen, viscose (crepe), satin, muslin, and broderie anglaise are just a few options.

**My soul
is fed
with needle
and
thread**



pattern pieces & seam allowances (in inches)

To sew the garment as described in the instructions, draw the illustrated seam allowances around the paper pattern pieces before cutting them out. If you are using a PDF pattern, the pattern can be printed with or without seam allowance.

To find out more, watch the [video](#).

- | | |
|-----------------------------------|------------------------------|
| 1. front: 2x | 5. skirt back: 2x |
| 2. back: 2x | 6. skirt back side: 2x |
| 3. skirt front: 1x on fabric fold | 7. facing: 1x on fabric fold |
| 4. skirt front side: 2x | 8. bias tape: 2x |

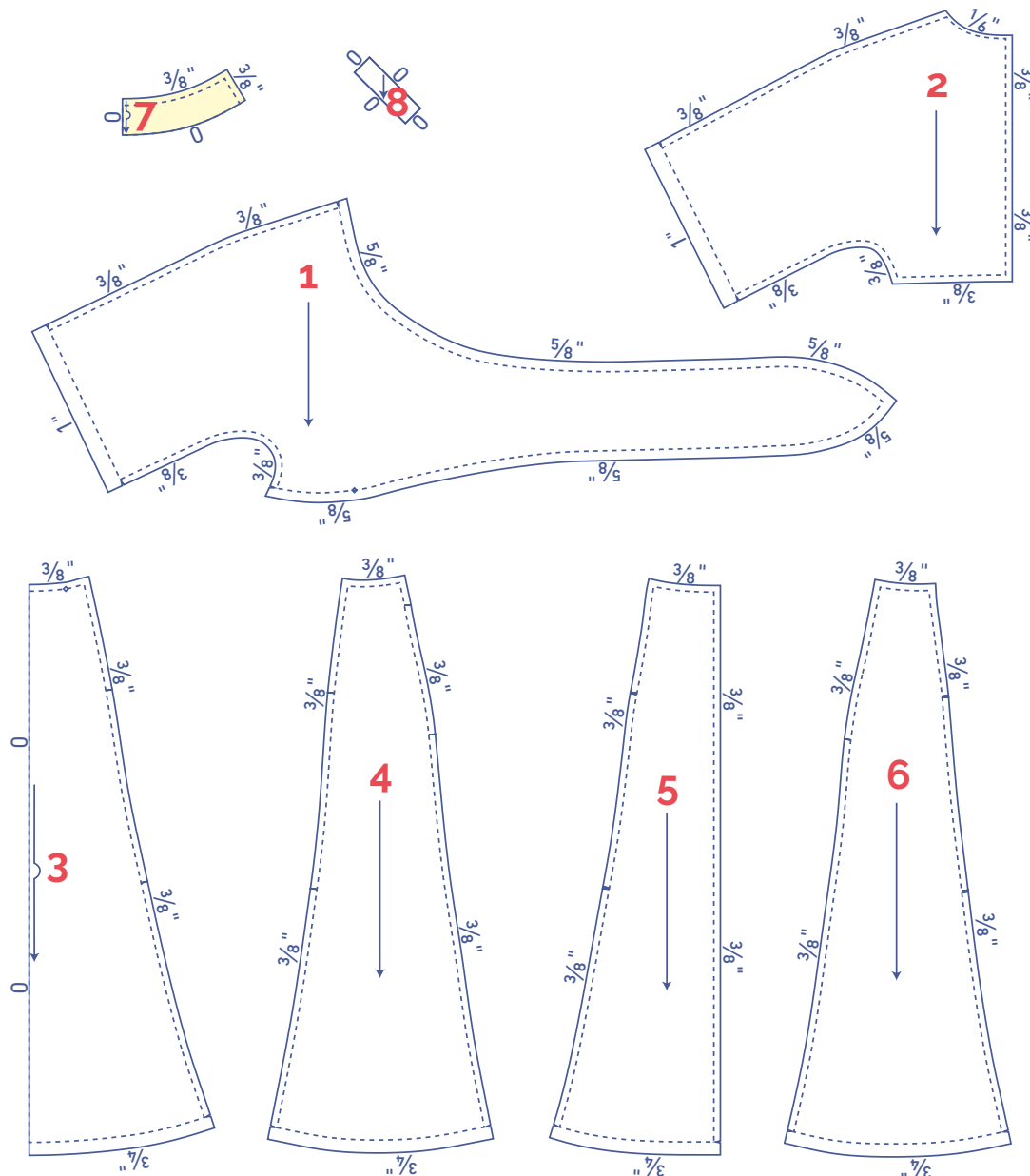

	material type
	fabric
	iron-on interfacing

fabric layout – solid fabrics fabric width 43"



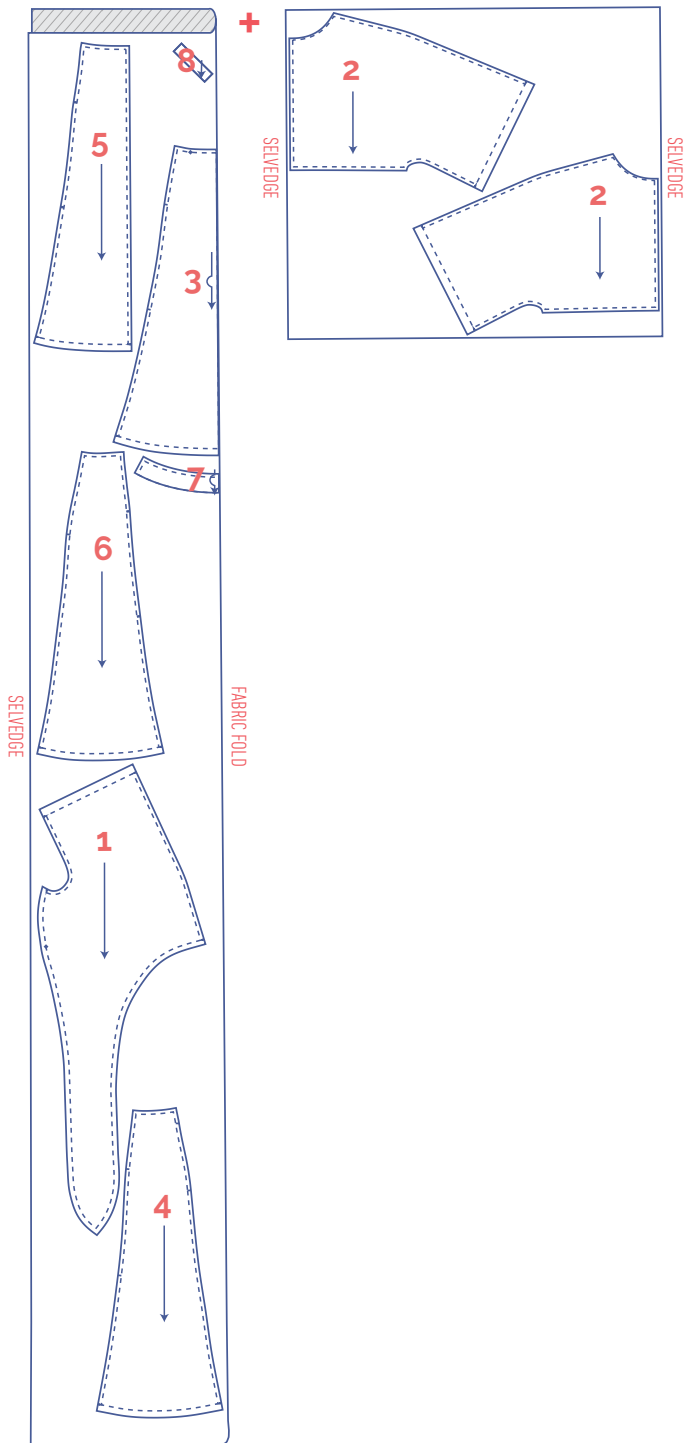

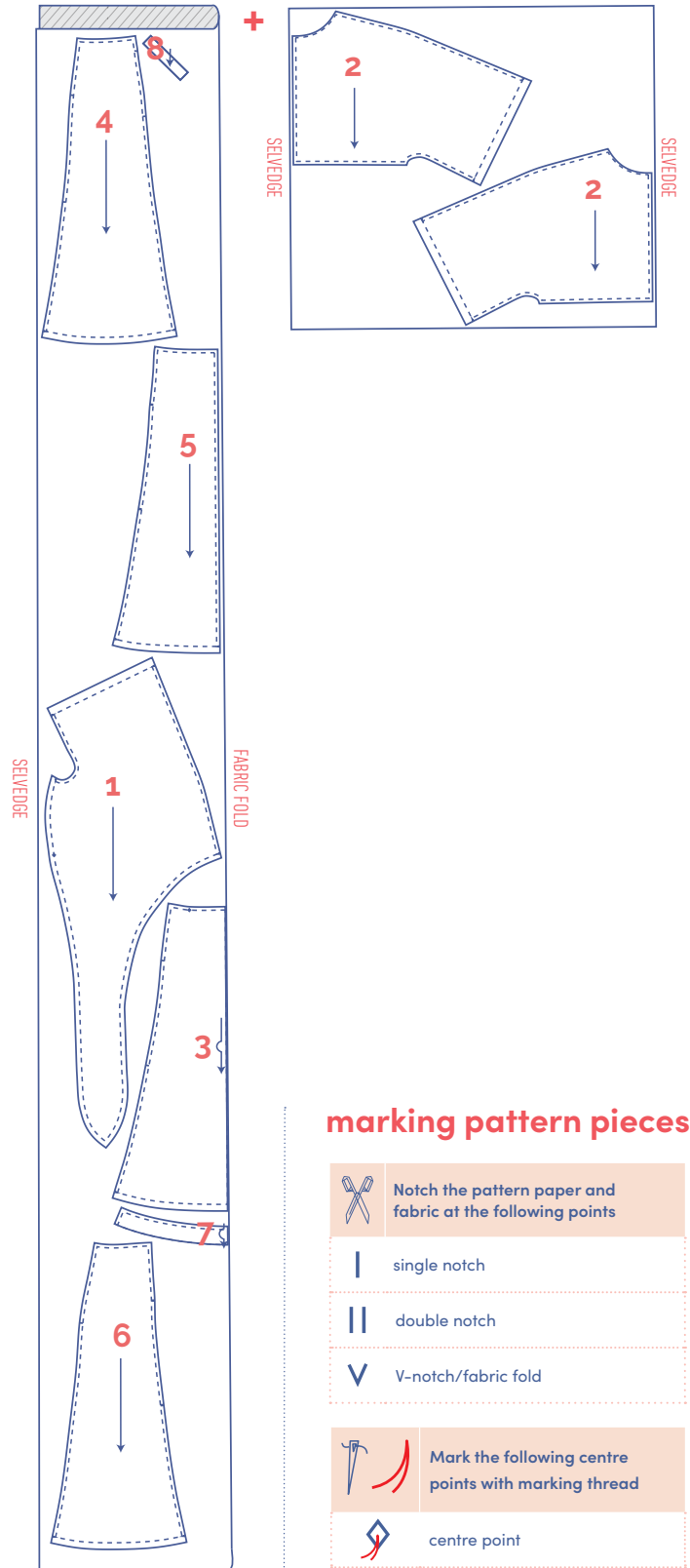

0 - 16



18 - 28



marking pattern pieces

	Notch the pattern paper and fabric at the following points
	single notch
	double notch
	V-notch/fabric fold
	Mark the following centre points with marking thread
	centre point

Important!

Pattern piece 1 is rotated at a 90° angle to fit the fabric width. Bear this in mind if you are working with a patterned or napped fabric.

Because the fabric is opened out as a single layer, you also need to cut mirror images of pattern piece 2. That's because you need a left and right back piece.

**fabric layout – solid fabrics
fabric width 55"**

0 - 16

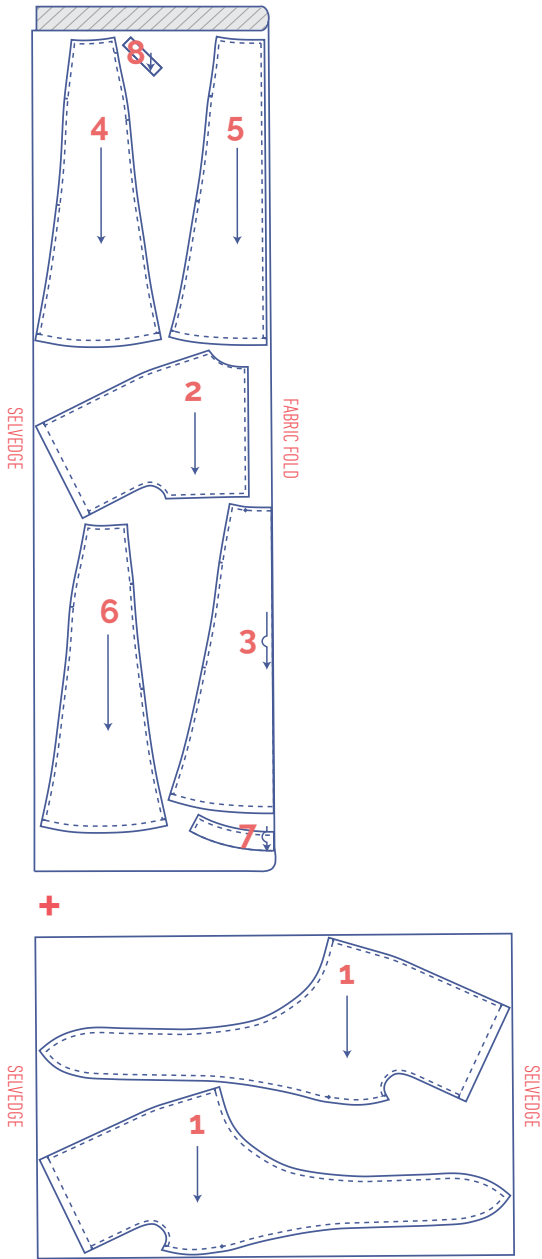

18 - 22

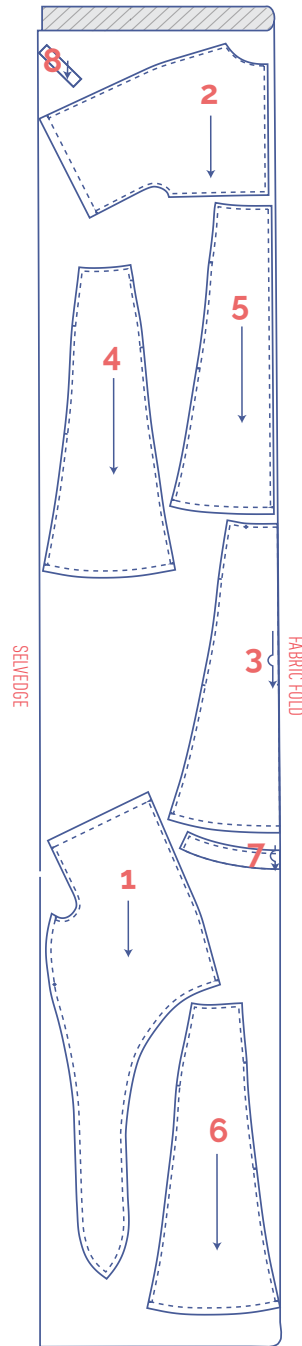

Important!
Pattern piece 1 is rotated at a 90° angle to fit the fabric width. Bear this in mind if you are working with a patterned or napped fabric.

Important!
Because the fabric is opened out as a single layer, you also need to mirror images of pattern piece 1. That's because you need a left and right front piece.

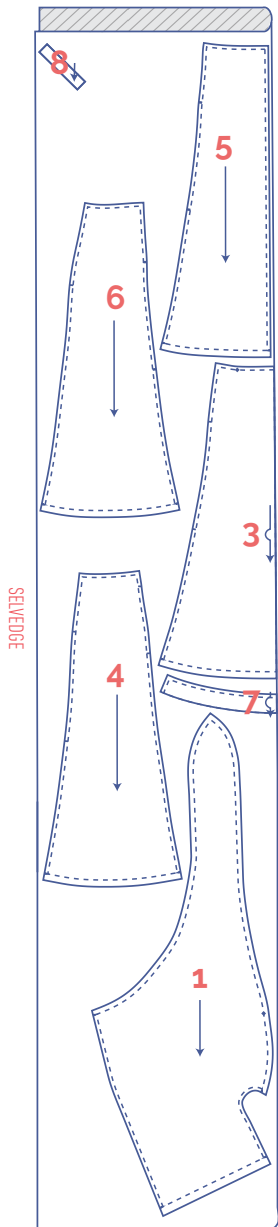





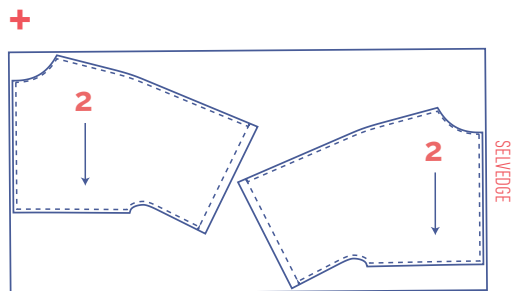

Important!

Pattern piece 1 is rotated at a 90° angle to fit the fabric width. Bear this in mind if you are working with a patterned or napped fabric.

Because the fabric is opened out as a single layer, you also need to cut mirror images of pattern piece 2. That's because you need a left and right back piece.



marking pattern pieces

 <p>Notch the pattern paper and fabric at the following points</p>	 <p>Mark the following centre points with marking thread</p>
 <p>single notch</p>	 <p>centre point</p>
 <p>double notch</p>	
 <p>V-notch/fabric fold</p>	

sewing instructions



The method used to finish the seams depends on the fabric used. The pieces are always sewn together with the right sides of the fabric facing, unless stated otherwise.

F front

B back

CF centre front

CB centre back

RBP right back 

LBP left back 

 right side

 wrong side

 iron-on interfacing

 elastic

1

Pin and sew each skirt back side (6) to a skirt back (5), matching the markings.

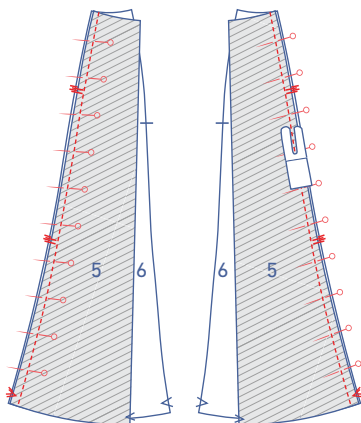

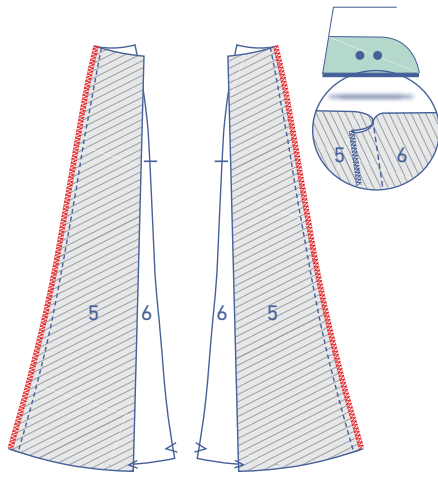

Finish the raw edges with overlock stitching. Press the seam allowance toward the CB.

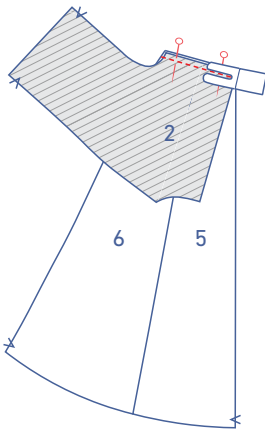

Pin and sew the skirt pieces to the back (2).

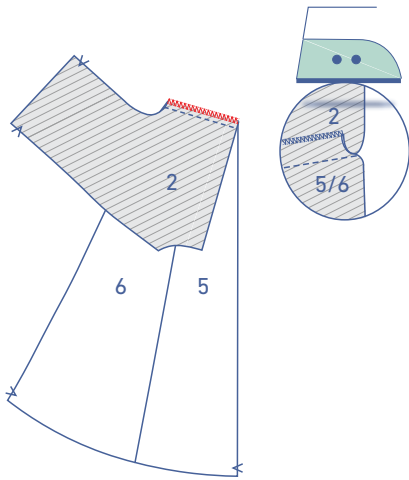

Finish the raw edges with overlock stitching. Press the seam allowance up towards the back.

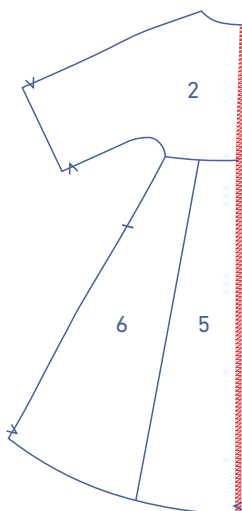

Finish the indicated edge with overlock stitching.

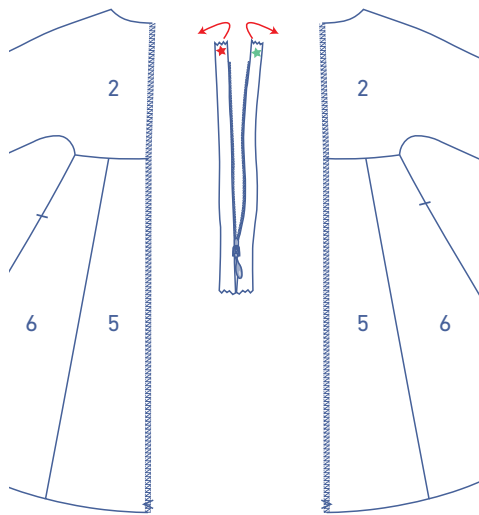

2

Place the back pieces in front of you with the right side facing up. Then place the concealed zip in front of you with the right side facing up. Open the zip.

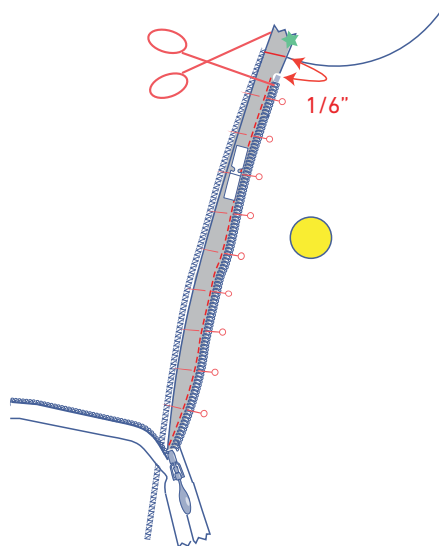

Fold the green star zip tape to the right and pin it to the RB. Line up the zip tape with the edge of the fabric, and the zip teeth $\frac{1}{6}$ " under the raw edge of the neckline. Trim the top of the zip tape to match the raw edge of the neckline and prevent any bunching. Sew into place with the invisible zipper foot.

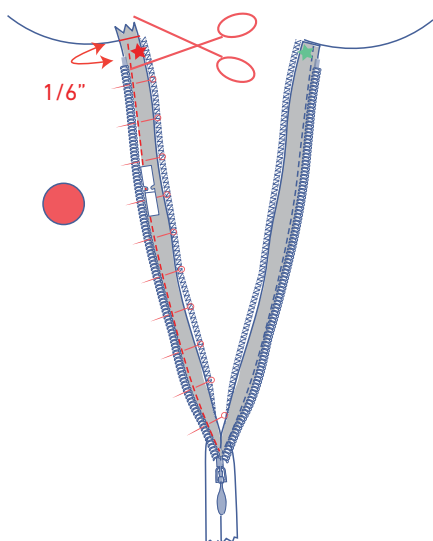

Fold the red star zip tape to the left and pin it to the LB. Line up the zip tape with the edge of the fabric. The zip teeth start $\frac{1}{6}$ " under the neckline's raw edge. Trim the top of the zip tape to match the raw edge of the neckline and prevent any bunching. Sew into place with the invisible zipper foot.

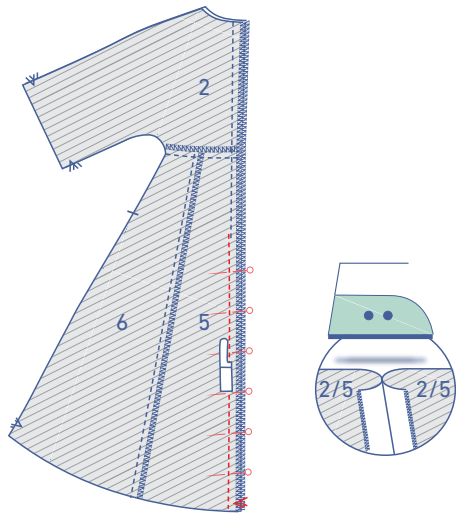

Close the zip and sew the rest of the CB seam with the zipper foot. Start sewing slightly above and right next to your previous stitching (where you attached the zip tapes). Press the seam allowance open.

3

Press the bias tape pieces (8) in half with the long ends together and the wrong sides of the fabric touching to create a fold line. Open back out.

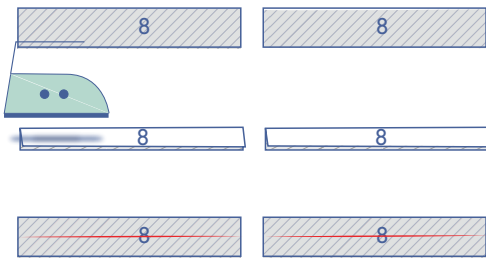

Now, fold the bias tape in half with the long ends together and the right sides touching. Sew one of the short ends closed.

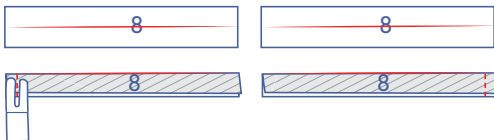

Turn the right way out.



Pin raw edges of the bias tape to the neckline of the back along the right side. Match the finished ends to finished CB lines.

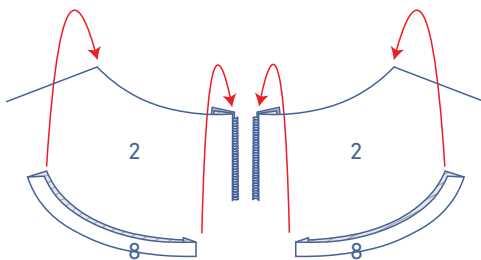

Snip off any excess bias tape as needed. The length and stretch of the tape will vary depending on the fabric type.

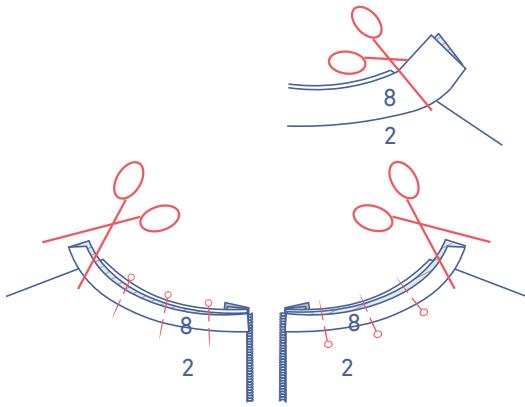

Sew the bias tape into place at 1/6" from the raw edge.

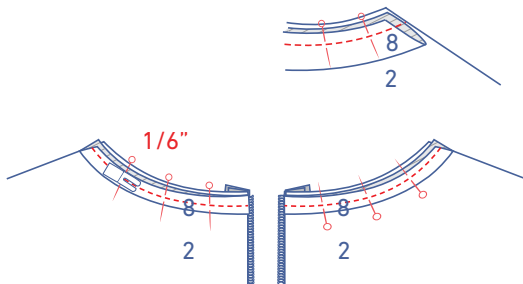

Fold the bias tape over and sew to the seam allowance underneath, anchoring it right next to the seam.

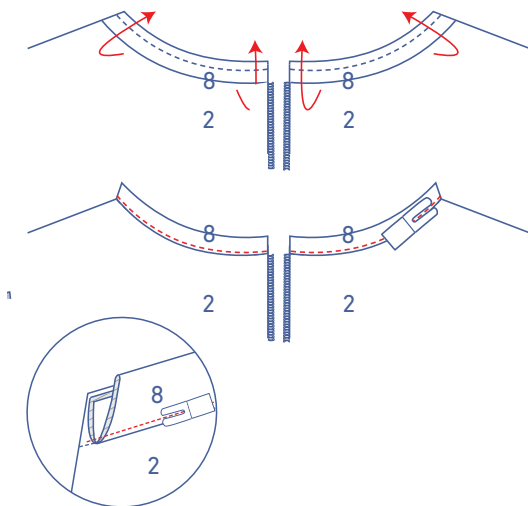

Fold the bias tape over to the wrong side, all the way around. Edgestitch into place.

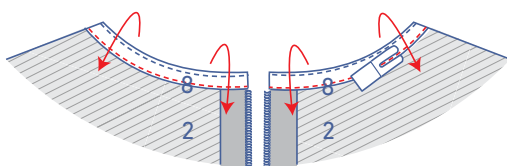

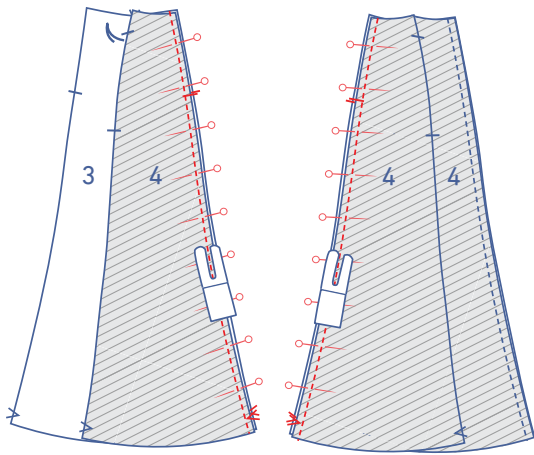

4

Pin and sew each skirt front side (4) to a skirt front (3), matching the markings.

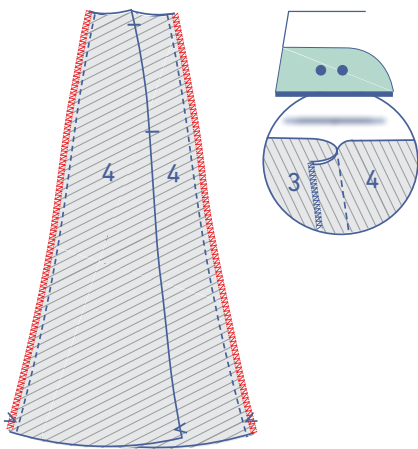

Finish the raw edges with overlock stitching. Press the seam allowance toward the CF.

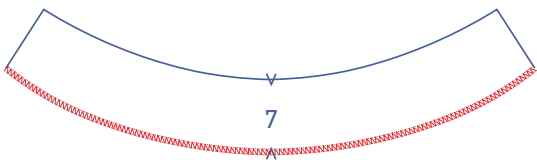

Finish the bottom of the facing (7) with overlock stitching.

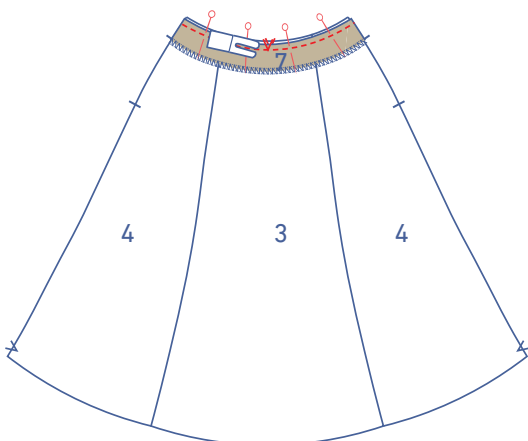

Pin and sew the top of the facing to the top of the skirt front.

Fold the facing over and sew the facing to the seam allowance underneath, anchoring it right next to the seam.

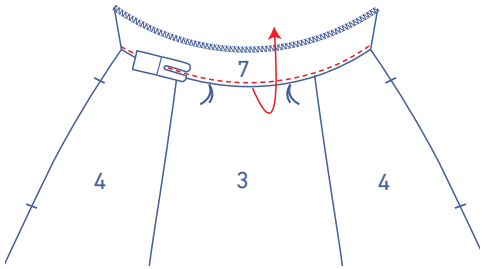
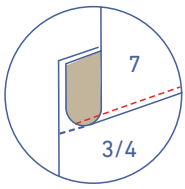

Then fold the facing all the way over to the wrong side. Pin the raw edges on the side of the facing temporarily to the side of the skirt.

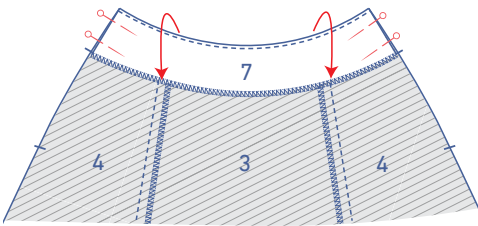

5

Pin and sew the shoulder seams of the front and back. The finished neckline of the back matches the V-notches in the front.

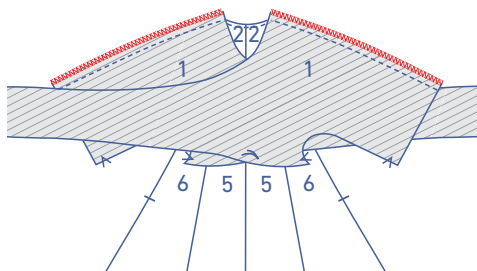
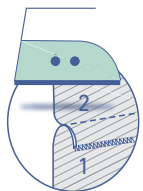
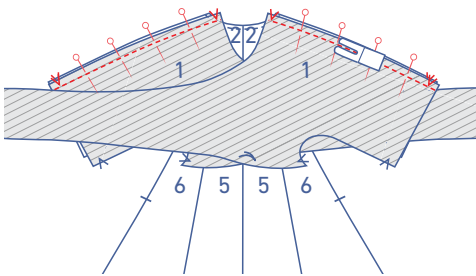
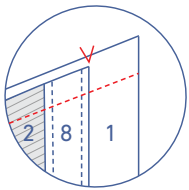

Finish the raw edges with overlock stitching. Press the seam allowance towards the front.

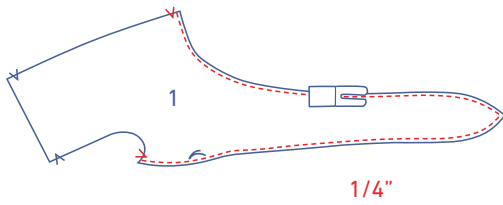

Sew at $\frac{1}{4}$ " from the indicated raw edges of the front.

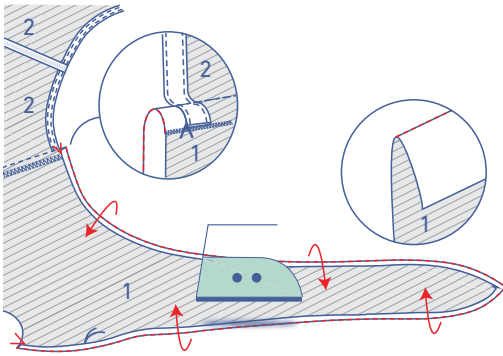

Press the edge over to the wrong side along the stitching line.

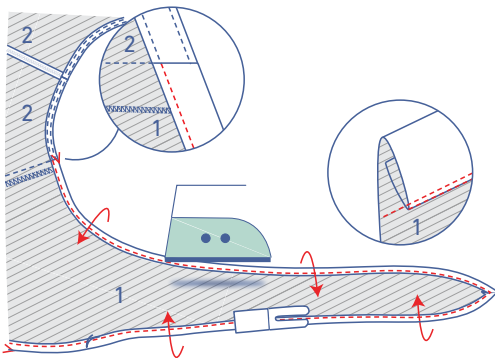

Fold over again and edgestitch into place.

6

Pin the front to the skirt (+ facing), matching the marking threads. Both pieces have right sides facing up. The fronts overlap the top of the skirt at the side seam. Match the finished bottom of the front to the diagonal notch at the side seam of the skirt.

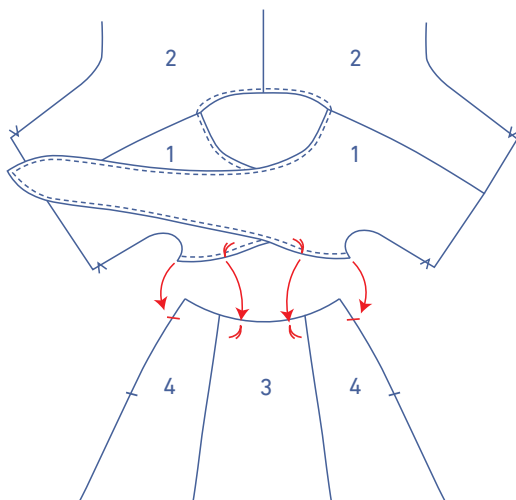

To finish the front, pin the front to the skirt where illustrated and sew into place.

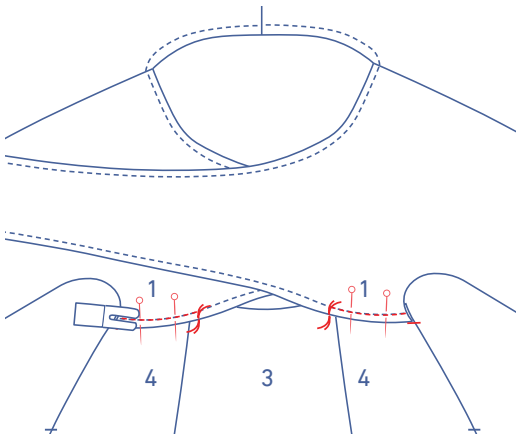

7

Now, pin the underarm and side seams together, matching the markings, and sew. Please note: the waist seam of the back matches the finished top of the skirt front.

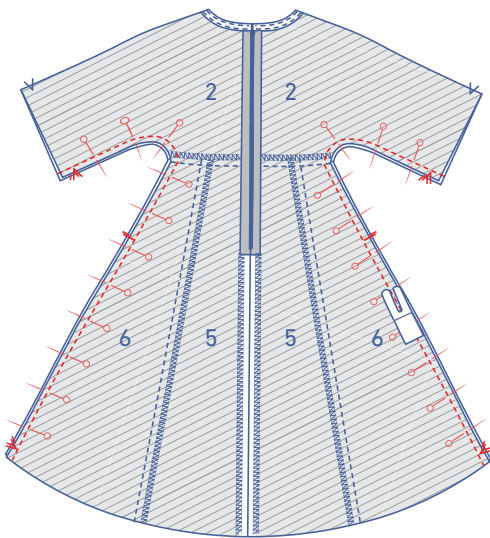

Finish the raw edges with overlock stitching.

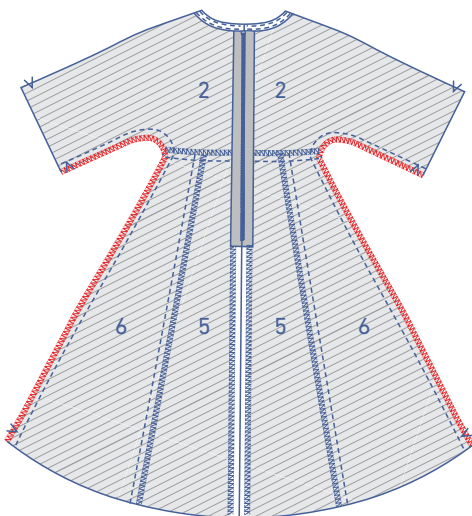

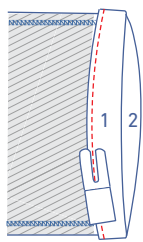
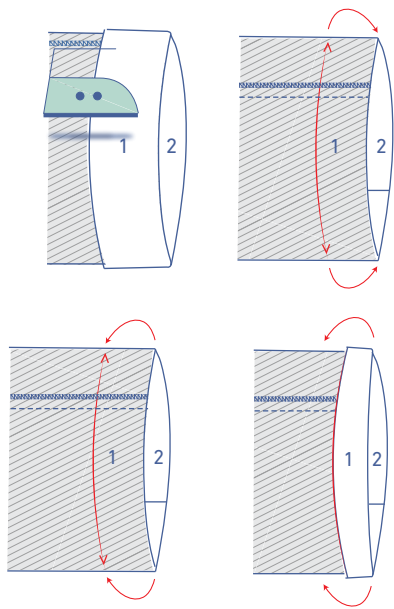

8.1 without elastic

Turn the sleeve hem allowance up towards the wrong side, press, and open back out.

Fold the raw edge to meet the pressed fold line and then fold over again.

Edgestitch into place.

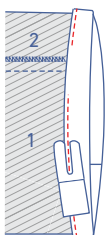
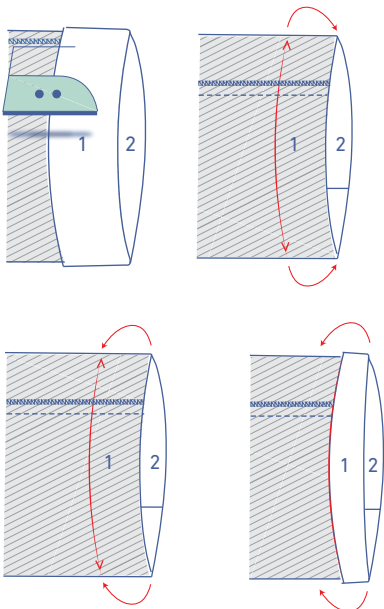

8.2 with elastic

Turn the sleeve hem allowance up towards the wrong side, press, and open back out.

Fold the raw edge to the pressed fold line and then fold over again.

Edgestitch into place, but leave a gap in the underarm seam through which to thread the elastic later.

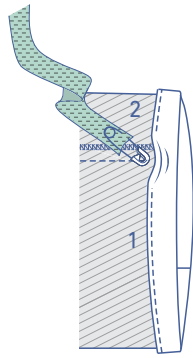

Thread the elastic through the casing.

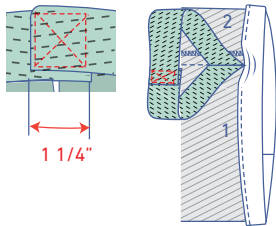

Overlap 1 ¼" of the ends and sew into place with a Box X stitch.



Tuck the elastic neatly back into the casing and sew the opening closed.

9

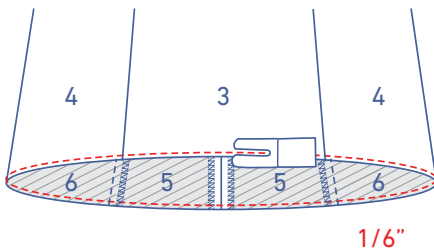

Sew all the way around the bottom of the dress at 1/6" from the raw edge.

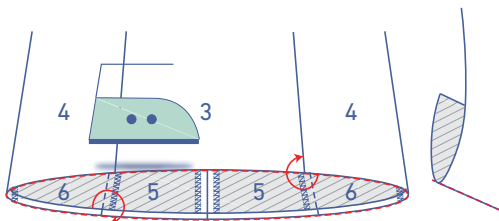

Then, press the edge over to the wrong side along the stitching line.

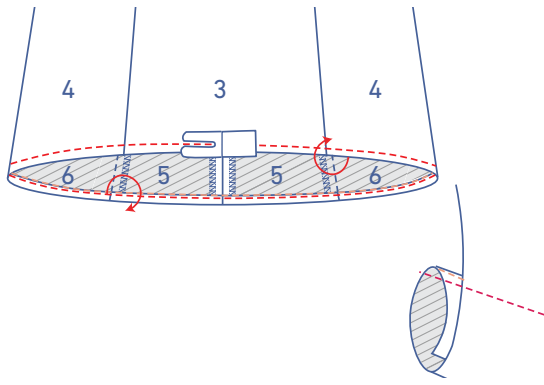

Turn the edge up again towards the wrong side. Edgestitch into place.

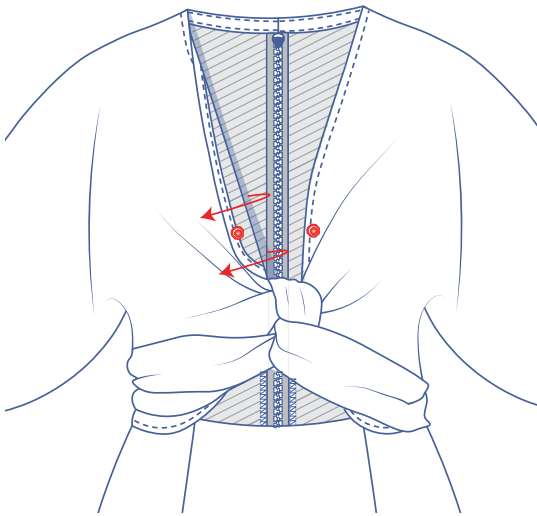

10

Optional: sew on a snap fastener for more coverage at the bust.