



Elba by Fibre ood

Elba by Fibre ood



XS - XXXL

Remember our classic Hunter coat pattern? That was our muse for this all-season waistcoat. Sometimes it's good to turn up the charm, which is why we gave Elba so many eye-catching details on the front. It's double-breasted and has an elegant collar with lapels, shoulder pads, a slash chest pocket, and side pockets. Fully lined, Elba feels extra luxurious. And the slit at the back ensures plenty of freedom of movement. Pair Elba with the [Freja trousers](#) or [Peaches trousers](#) for a guaranteed show-stopper. This waistcoat is bound to be an all-seasons classic – timeless with a subtle unisex feel.

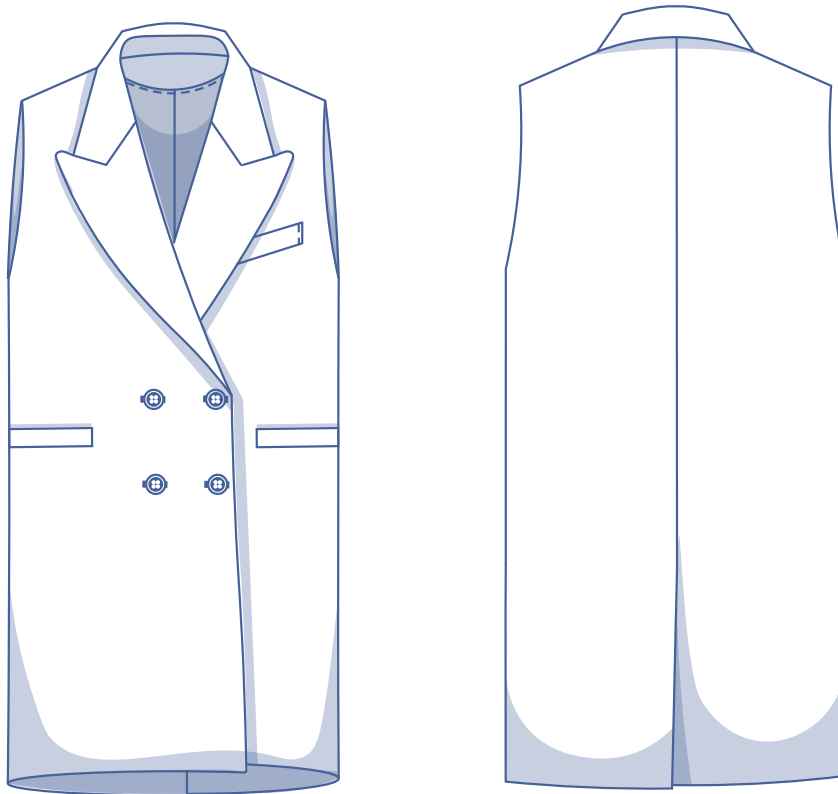

size chart (in inches)

size	XS		S		M		L		XL		XXL		XXXL		
	0	2	4	6	8	10	12	14	16	18	20	22	24	26	28
body height	5' 25"	5' 38"	5' 45"	5' 48"	5' 51"	5' 54"	5' 58"	5' 61"	5' 64"	5' 64"	5' 64"	5' 64"	5' 64"	5' 64"	5' 64"
B (bust)	29.9	31.5	33.1	34.6	36.2	37.8	39.4	40.9	43.3	45.7	48	50.4	52.8	55.1	57.5
H (hips)	33.9	35.4	37	38.2	39.4	40.6	41.7	42.9	45.3	47.2	49.2	51.2	53.1	55.1	57.1

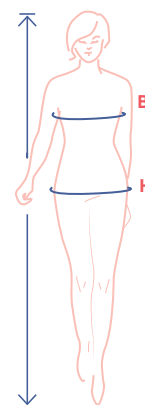

Select a size based on your **bust measurement**. If your hip measurements are wider than those in the size chart, check the hip measurements in the chart below to see if there is enough room or whether the pattern needs to be altered. It's easy to do. When tracing the pattern, simply trace from the line of one size to the line of the other.

pattern measurements (in inches)

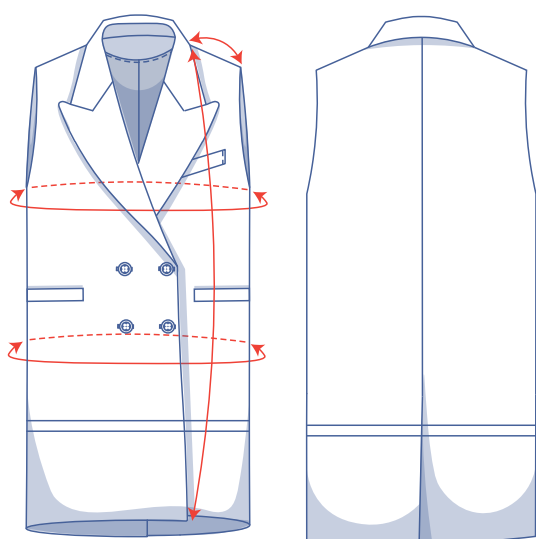

— shorten or lengthen the pattern here

This chart's measurements are the pattern measurements based on the fabric type and serve as a reference. Ease has been added to the width measurements (on top of the exact body measurements) for a more comfortable fit. Elba is designed to have a **relaxed fit**. Depending on the fit you have in mind, you could go a size smaller or larger than the recommended size.

size	XS	S	M	L	XL	XXL	XXXL
length	36.4	37.1	37.8	38.5	39.4	40.3	41.3
shoulder length	6.1	6.3	6.5	6.8	7	7.3	7.5
bust	36.2	39.4	42.5	45.7	49.6	54.3	59.1
hips	38.4	41.6	44.7	47.9	51.8	56.6	61.3

Compare the stated lengths to the measured or desired lengths. **Lengthen** or **shorten** the waistcoat by cutting the pattern pieces at the indicated double lines. Then either increase the distance between the cut pieces by the desired amount (to lengthen) or overlap the pieces (to shorten). Make sure that the CF and CB lines and the side seams are always straight.

IMPORTANT

Adjust the amount of fabric to be used based on these alterations.

notions



- Thread
- Iron-on interfacing: max. 3.1 yd
- Buttons (Ø 1"): 6
- Shoulder pads: 2
- Lining: see table
- Fabric: see table

lining fabric use		XS	S	M	L	XL	XXL	XXXL
fabric width 43"	yd	1 ½	2	2	2 ¼	2 ¼	2 ½	2 ½
fabric width 55"	yd	1 ¼	1 ½	1 ½	1 ½	2	2	2

The corresponding fabric layout can be found on page 6 of these sewing instructions.

fabric use		XS	S	M	L	XL	XXL	XXXL
fabric width 43"	yd	3	3 ¼	3 ¾	3 ¾	3 ¾	4	4
fabric width 55"	yd	2 ½	2 ½	2 ½	2 ¾	2 ¾	3	3

The corresponding fabric layout can be found on page 6 of these sewing instructions.

fabric advice



Elba looks lovely in heavier fabrics that provide enough structure. Woollen fabrics or wool blends, e.g. boiled wool, gabardine, tweed, and flannel, are excellent choices. Corduroy, velvet, jacquard, (faux) leather, and denim will also look great.



MEASURE

twice

&





CUT

once

pattern pieces & seam allowances (in inches)

To sew the garment as described in the instructions, draw the illustrated seam allowances around the paper pattern pieces before cutting them out. If you are using a PDF pattern, the pattern can be printed with or without seam allowance. To find out more, watch the [video](#).

1. front: 2x
2. back: 2x
3. upper collar: 1x on the fabric fold
4. undercollar: 1x on fabric fold
5. facing front: 2x
6. facing back: 2x
7. armhole facing front: 2x
8. armhole facing back: 2x
9. lining front: 2x
10. lining RB: 1x
11. lining LB: 1x
12. chest pocket flap: 1x
13. chest pocket opening: 1x
14. inner pocket bag for chest pocket: 1x
15. pocket opening: 2x
16. welt with inner pocket bag: 2x
17. pocket: 4x

 material type
 fabric
 iron-on interfacing
 lining

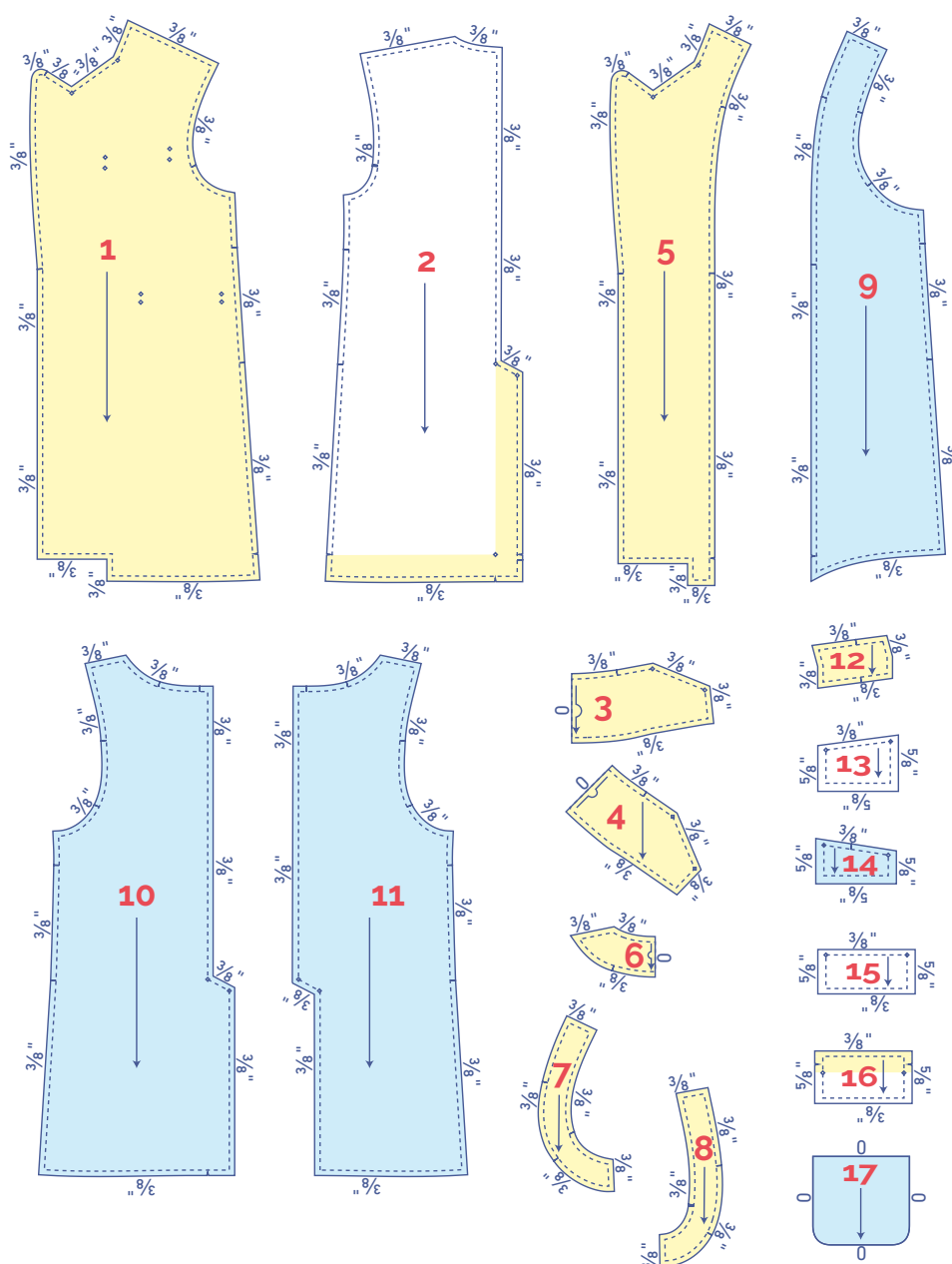

TIP!

The undercollar is smaller than the upper collar and is cut on the bias. This means the seam line won't show on the right side.

fabric layout – solid fabrics
fabric width 43"

XS - S

M - XXXL

Important!
 You only need pattern piece 4 once.

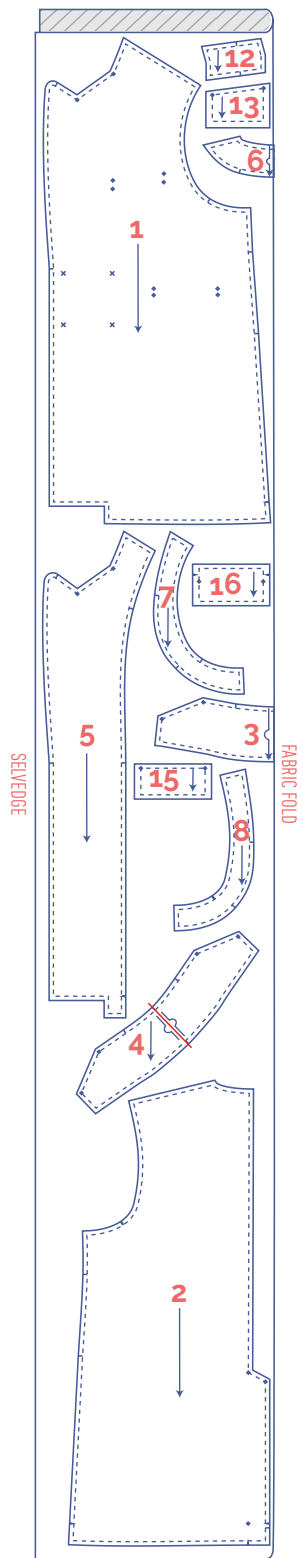
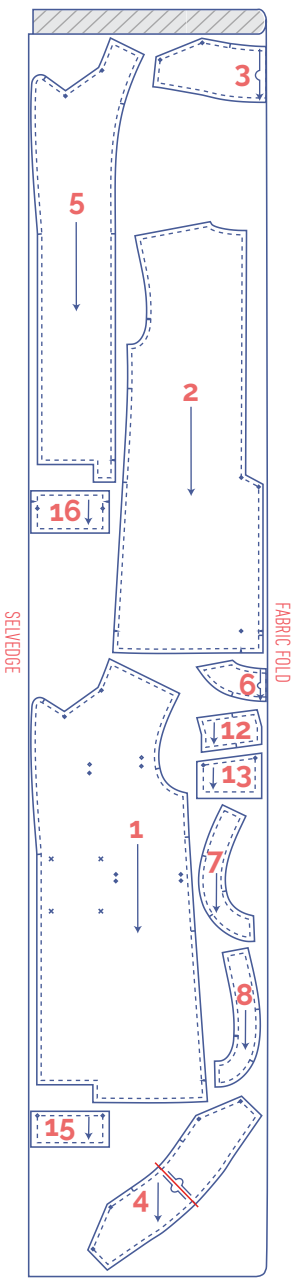

Important!
 You only need pattern piece 4 once.

marking pattern pieces

	Notch the pattern paper and fabric at the following points
	single notch
	double notch
V	V-notch/fabric fold
	Mark the following centre points with marking thread
	centre point
	buttons



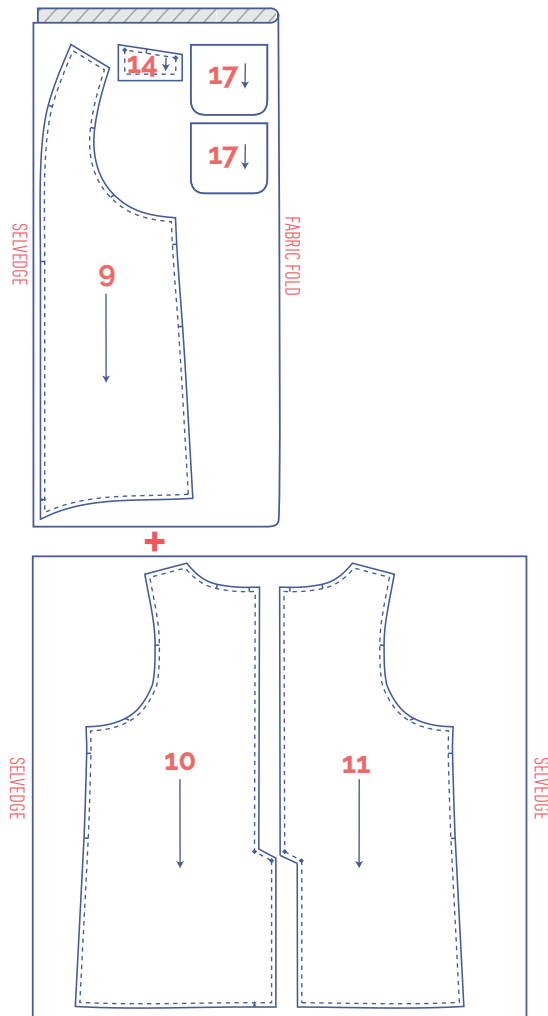
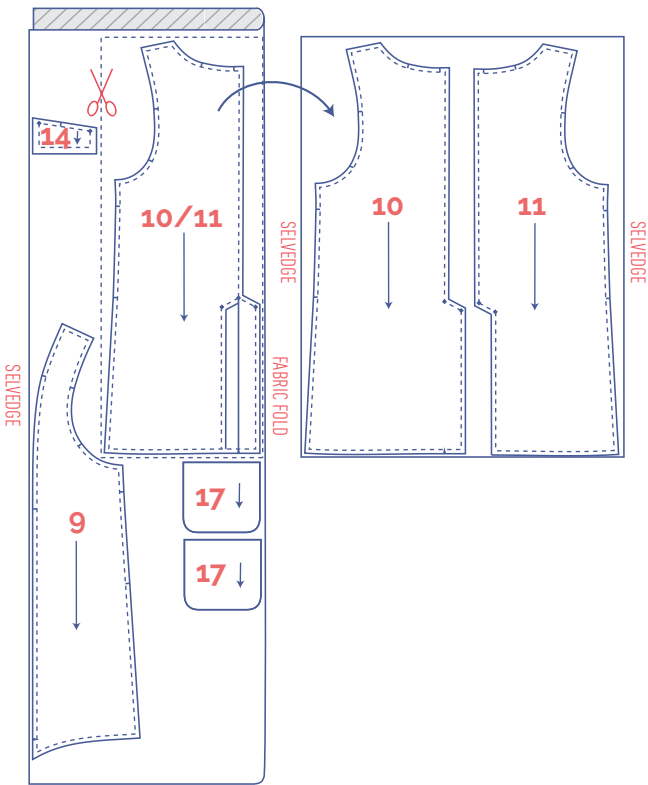

fabric layout for linings fabric width 43"

XS - M

L - XXXL



marking pattern pieces

	Notch the pattern paper and fabric at the following points
	single notch
	double notch
∨	V-notch/fabric fold
	Mark the following centre points with marking thread
	centre point
	buttons

fabric layout – solid fabrics fabric width 55"

XS - XXL

XXXL

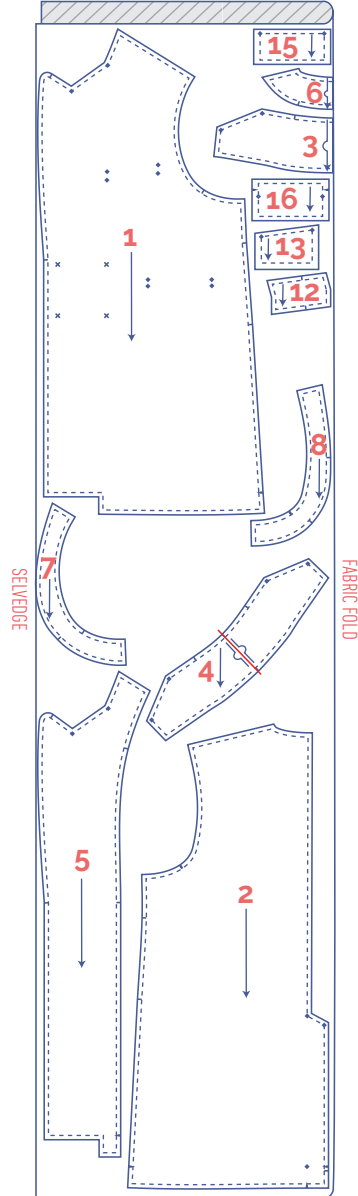
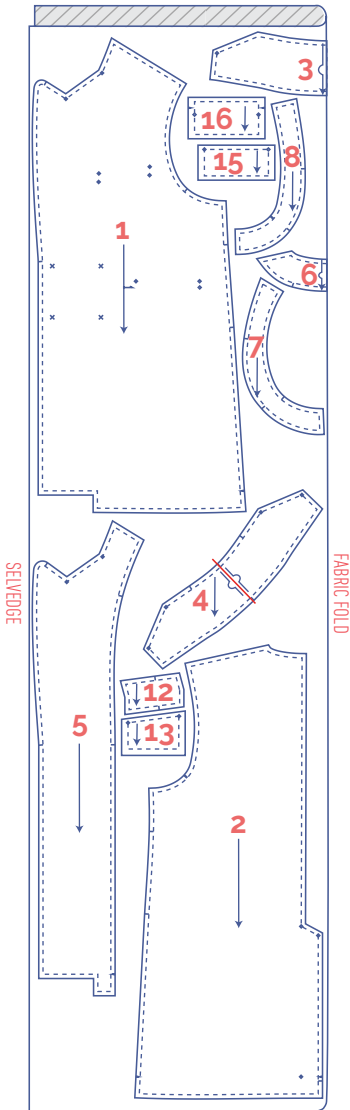

Important!
You only need pattern piece 4 once.

Important!
You only need pattern piece 4 once.

marking pattern pieces



Notch the pattern paper and fabric at the following points

| single notch

|| double notch

∨ V-notch/fabric fold



Mark the following centre points with marking thread

◇ centre point

✕ buttons

fabric layout for linings fabric width 55"

XS - L

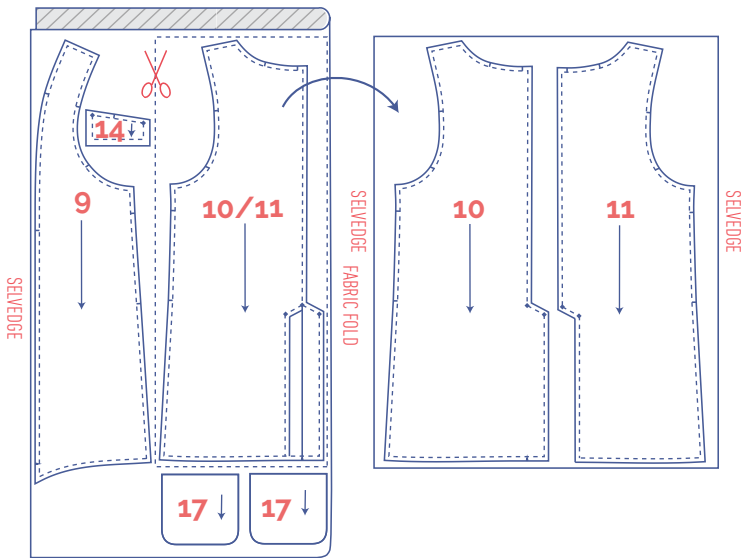

XL - XXXL

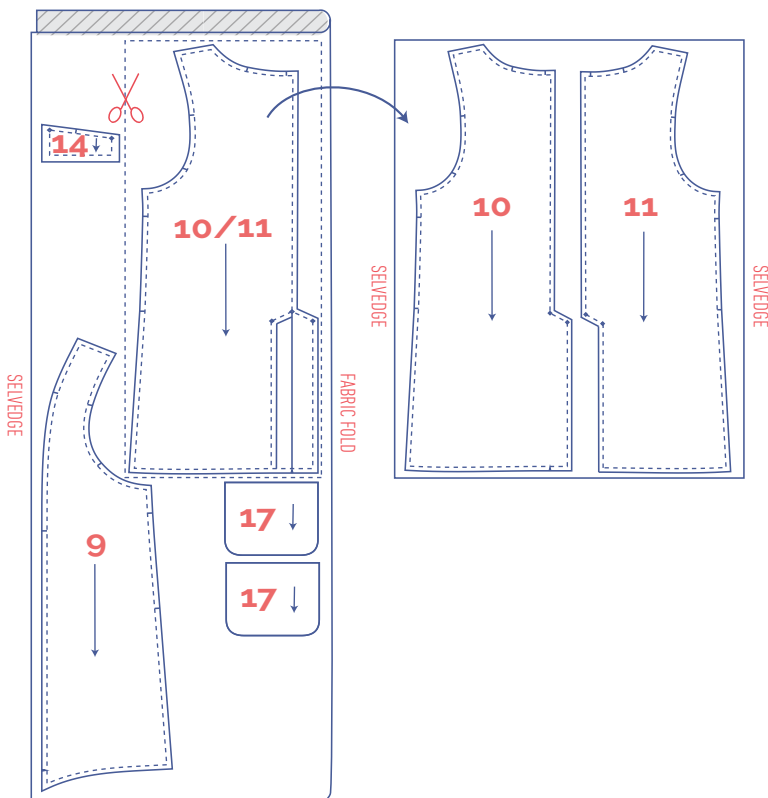

marking pattern pieces



Notch the pattern paper and fabric at the following points



single notch



double notch



V-notch/fabric fold



Mark the following centre points with marking thread



centre point



buttons

sewing instructions



The method used to finish the seams depends on the fabric used. The pieces are always sewn together with the right sides of the fabric facing, unless stated otherwise.

F front

B back

RF right front 

LF left front 

CF centre front

CB centre back

RBP right back 

LBP left back 

 right side

 wrong side

 lining right side

 lining wrong side

 iron-on interfacing

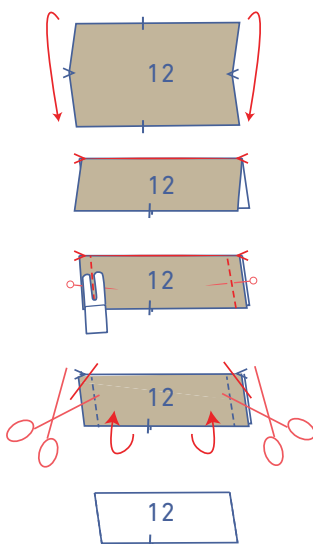

1

Fold the chest pocket flap (12) in half with the long ends together and the right sides of the fabric touching. Sew the short ends closed. Clip the corners and turn the right way out.

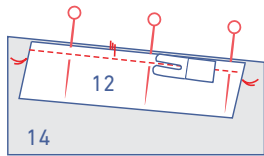

Pin the raw edges of the flap to the slanted end of the chest pocket's inner pocket bag (14), matching the notches.

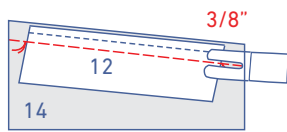

PLEASE NOTE: if the notches don't match, then your flap is upside down. The finished flap should be between the marking threads, so that seam allowance of the inner pocket remains on either side of the flap. Sew into place at presser foot width.

Sew a line of tacking $\frac{3}{8}$ " parallel to the raw edges from one end to the other (i.e. through the marking threads). Use a long stitch length at a low thread tension.

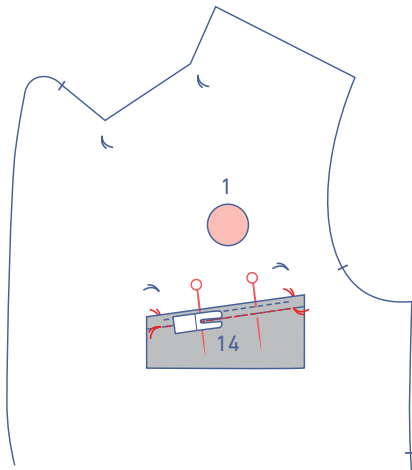

Place the flap and the chest pocket's inner pocket bag on the LF (1) so that the inner pocket bag's marking threads match the bottom marking threads on the front. The flap front and right side of the front should be matching with the straight end of the inner pocket bag facing the hem. Sew to the front along your previous line of tacking from marking thread to marking thread.

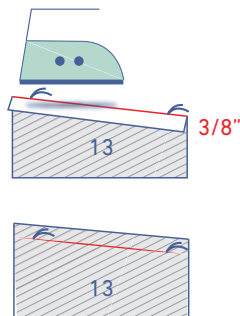

On the edge close to the marking threads, press $\frac{3}{8}$ " of the chest pocket opening (13) towards the wrong side to create a fold line. Open back out.

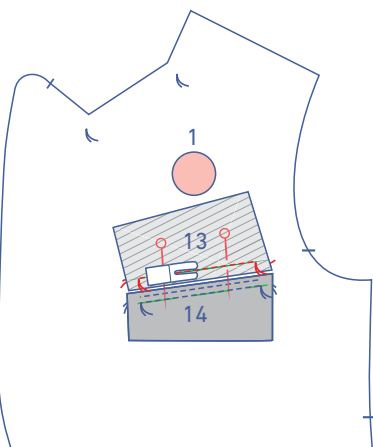

Place the chest pocket opening right side down on the front. Match the marking threads on the chest pocket opening to the marking threads on the front pocket as shown. The raw edge should match the inner pocket bag's raw edge. Sew to the front over the fold line from one marking thread to the other.

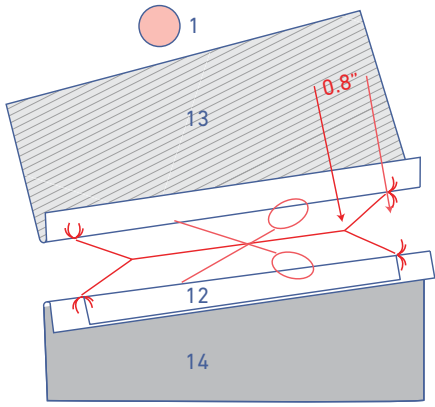

Snip into the front between the two lines of stitching. Start and stop cutting at 0.8" from the marking threads then clip diagonally to each corner from the ends of your cut. Only clip into the front. Do not cut the pocket pieces.

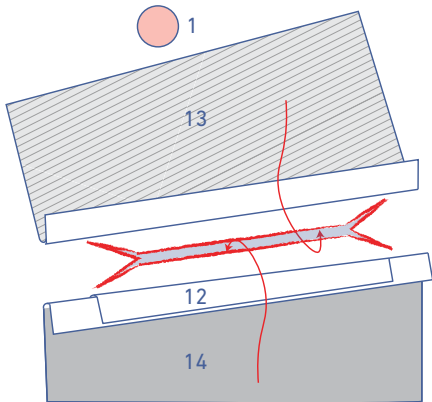

Pull the inner pocket bag and the pocket opening through the cut to the wrong side.

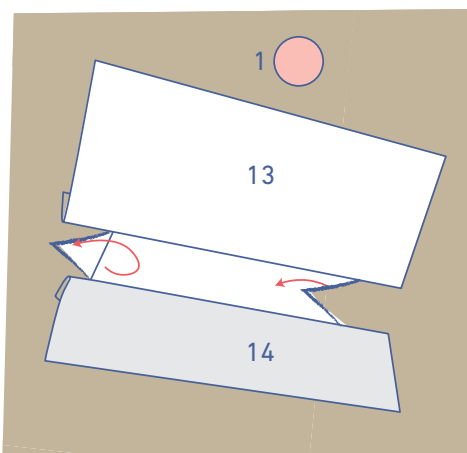
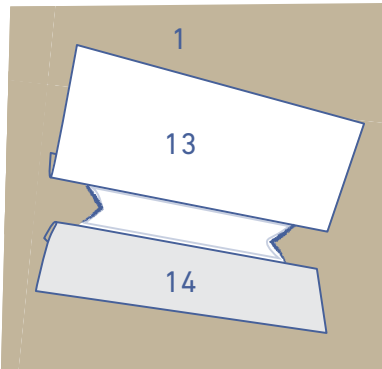

Push the triangles (from the diagonal clipping) on either side of the pocket opening towards the wrong side as well.

Place the flap neatly onto the right side of the LF.

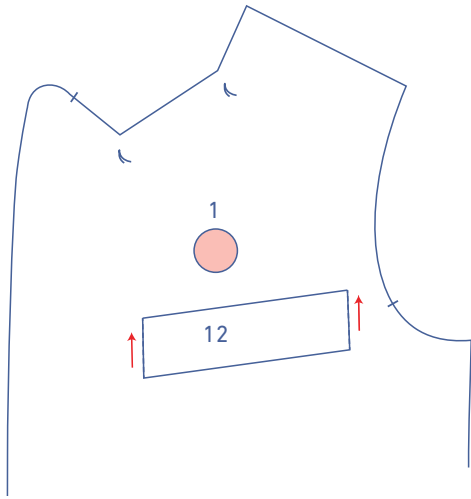

Sew the short ends of the flap to the right side of the front right next to the edge.

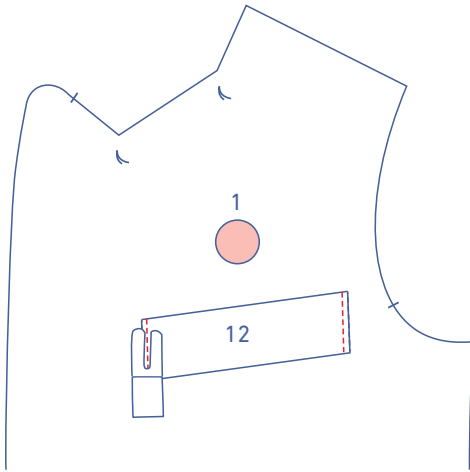

Fold the front out of the way and sew the contours of the pocket pieces at $\frac{5}{8}$ ".

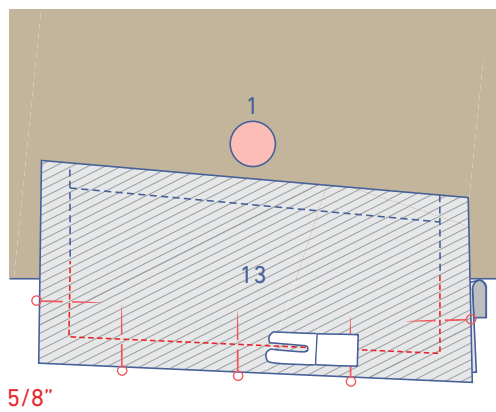

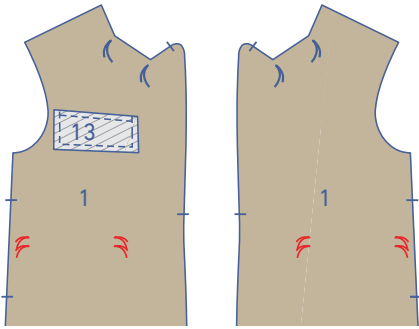

2

Draw straight chalk lines on the wrong side of the front to connect the corners of the lower pocket opening (marked with marking threads) and create a $\frac{5}{8}$ " x 6" rectangle.

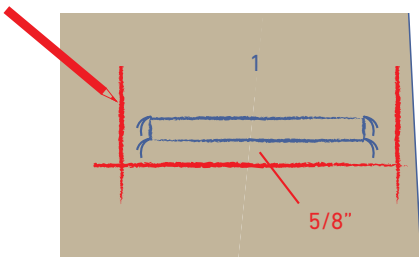
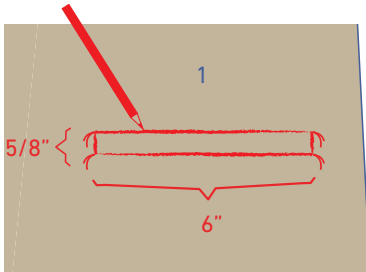

Draw a temporary line parallel to and $\frac{5}{8}$ " under the bottom long end of the pocket opening and two temporary lines parallel to and $\frac{5}{8}$ " away from the short ends.

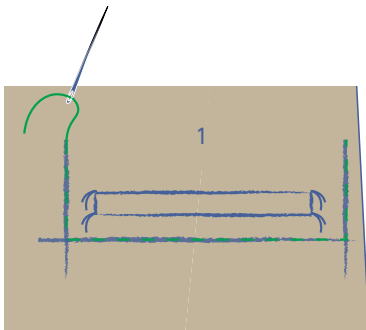

Use brightly-coloured thread to tack along these chalk lines. That will make them visible on the right side of the front.

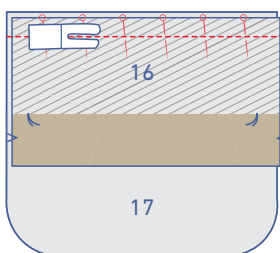

Pin and sew the bottom of the flap + inner pocket bag (16) to the top of the pocket (17).

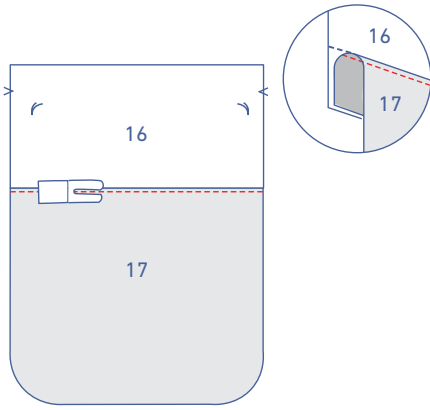

Fold the seam allowance towards the pocket. Sew the pocket right next to the seam, anchoring all layers (pocket + underlying seam allowance).

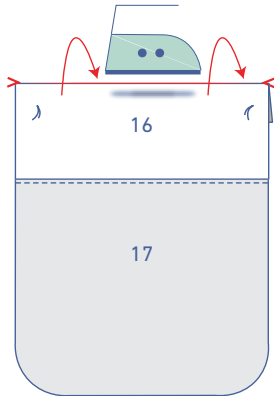

Press the flap towards the wrong side at the V-notches with the right sides of the fabric touching.

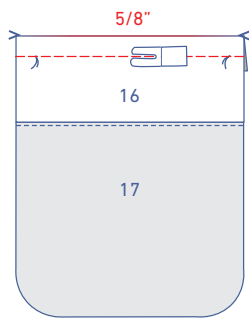

Sew a line of tacking (set to a long stitch length) 5/8" parallel to the fold line.

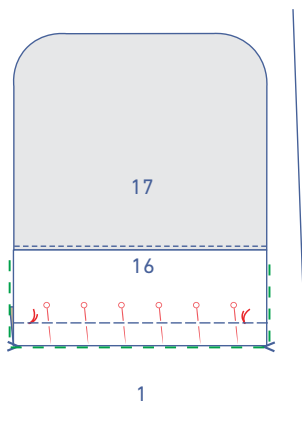

Place the flap + inner pocket bag construction on top of the front, right sides together. Match the edges to the tacking with the coloured thread as shown. Pin the flap + pocket to the front, matching the marking threads that mark the ends of the flap.

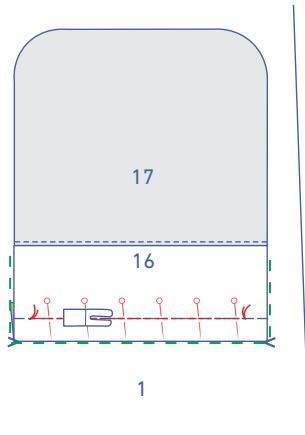

Sew the flap + inner pocket bag to the front along your previous tacking, only between the marketing threads.

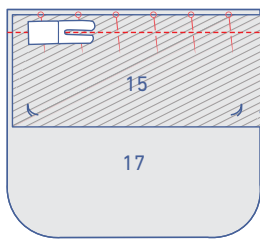

Pin and sew the bottom of the pocket opening (15) to the top of the pocket lining.

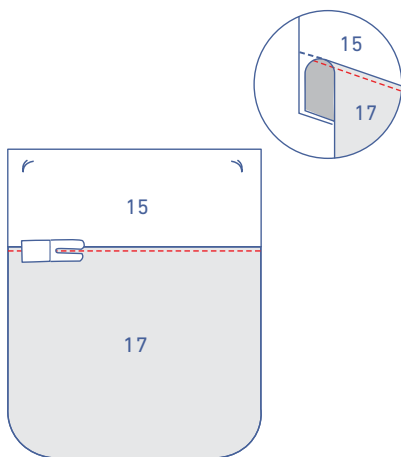

Fold the seam allowance towards the pocket. Sew the pocket right next to the seam, anchoring all layers (pocket + underlying seam allowance).

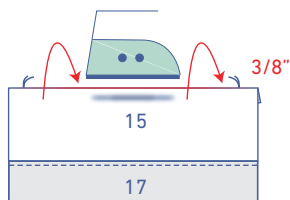

Press $\frac{3}{8}$ " of the pocket opening towards the wrong side to create a fold line. Open back out.



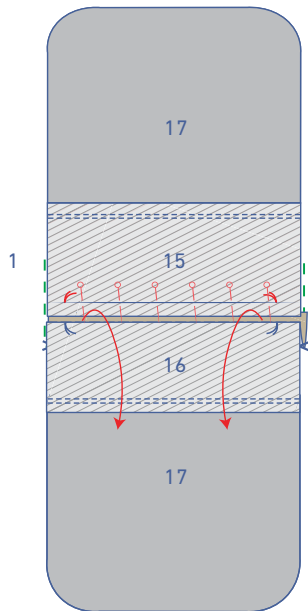

Fold the inner pocket bag + pocket lining (16 + 17) over at the stitching. Pin the pocket opening + pocket lining (15 + 17) to the front, matching the marking threads. Tip: the seam allowances will slightly overlap.

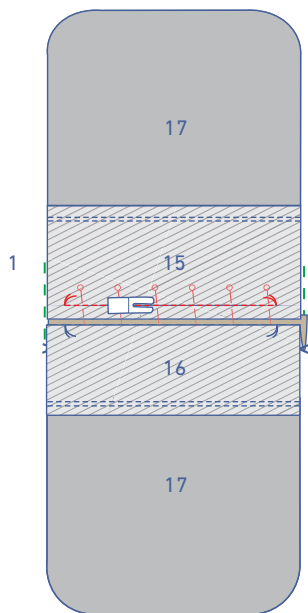

Sew over the fold line between marking threads.

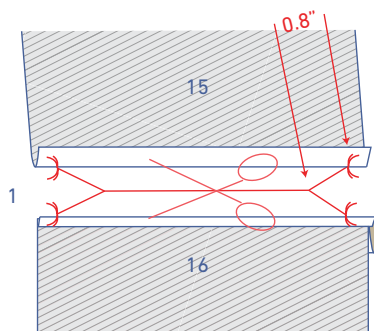

Fold both pocket pieces over and snip into the front between the two lines of stitching. Start and stop cutting at 0,8" from the marking threads then clip diagonally to each corner from the ends of your cut. Only snip into the front. Do not cut the pocket pieces.

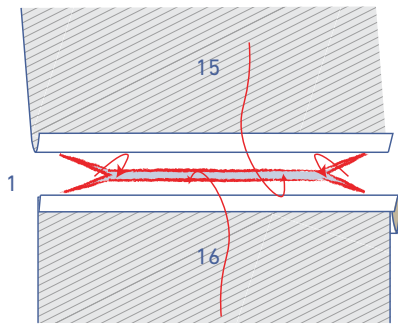

Push the pocket pieces through the opening towards the wrong side of the front. Push the triangles (from the diagonal clipping) on either side of the pocket opening towards the wrong side as well.

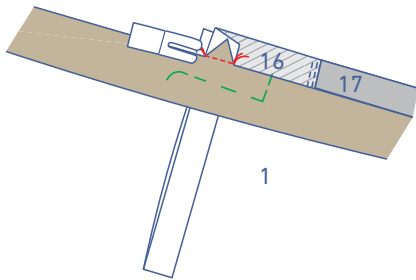

Lay both pocket pieces neatly flat. Fold the front over and sew the triangles to the pocket pieces, working from corner to corner, along both sides. Check that you have made clean right angles for the flap on the right side.

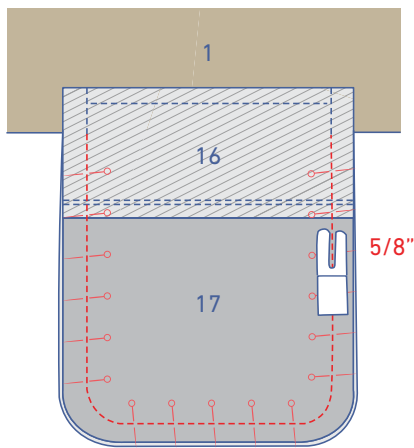

Pin and sew the contours of the pocket pieces together at 5/8".

3

Pin the CB seam to the back (2) pieces. Sew from the neckline to the top marking thread and then continue sewing to the next marking thread.

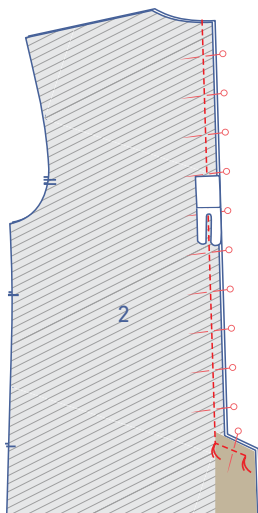

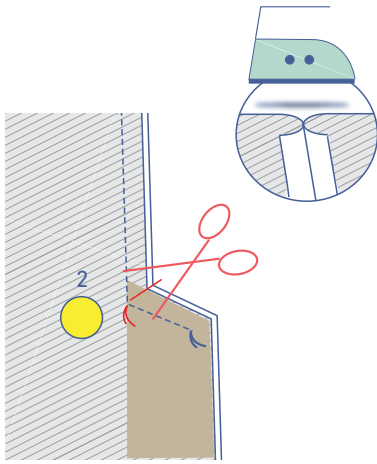

Diagonally clip the RB's seam allowance at the top marking thread in order to press open the seam allowance above.

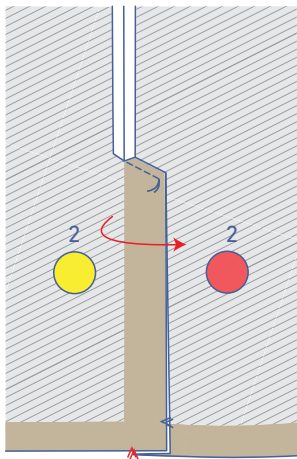

Angle the facing pieces of the slit towards the LB and smooth everything flat. The LB facing should be folded in half with the V-notches at the bottom of the RB and LB matching.

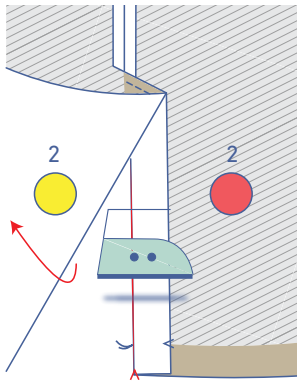

Open the RB's facing out and press the LB to create a fold line between the marking thread at the top of the slit and the V-notch in the hem. Open back out.

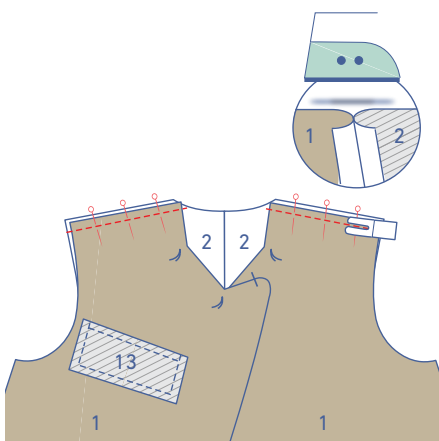

4

Pin and sew the shoulder seams of the front and back together. Press the seam allowance open.

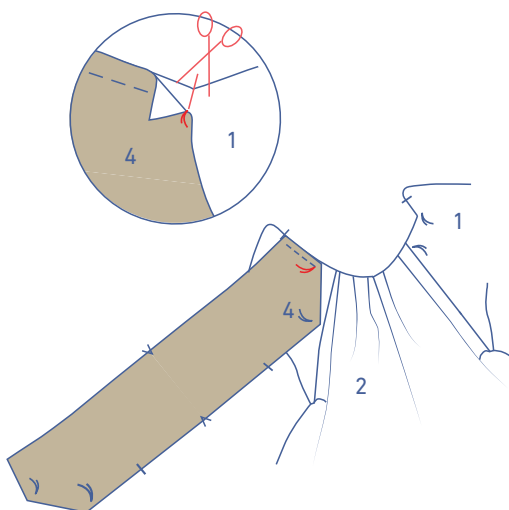
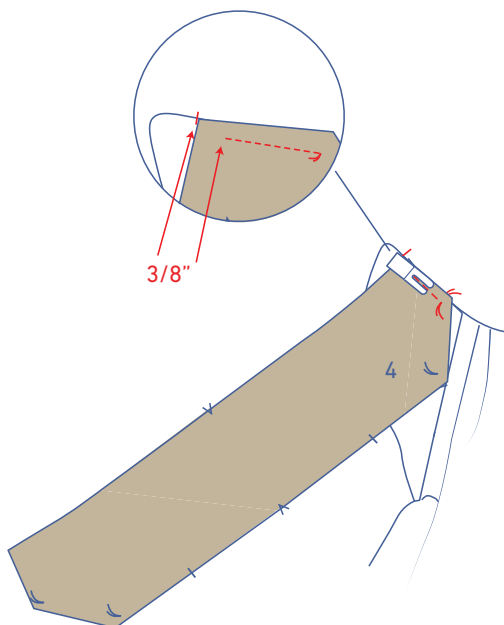
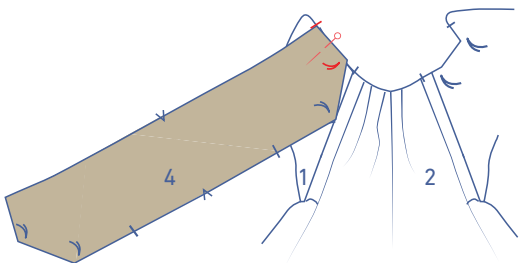
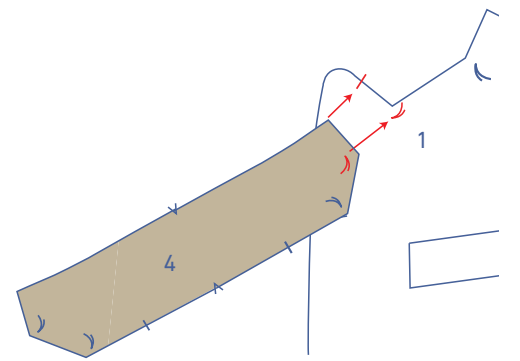

5

Match the short end of the undercollar (4) (the collar cut on the bias) to the single notch and marking thread in the front lapel. The rest of the collar points downwards. The first marking thread in the corner of the collar matches the first marking thread in the corner of the front.

Pin and sew this end of the collar up to the collar up to the first marking threads. Start sewing at $\frac{3}{8}$ " from the notch.

Leave the needle lowered into the fabric there. Raise the presser foot and fold over the corner of the collar. Snip into the seam allowance of the front, stopping just before the needle. Turn the garment to realign the raw edges and then lower the presser foot back down.

Now, sew the next edge between the marking threads. Leave the needle lowered into the fabric at the second marking thread. Raise the presser foot and fold over the corner of the collar. Snip into the seam allowance of the front, stopping just before the needle.

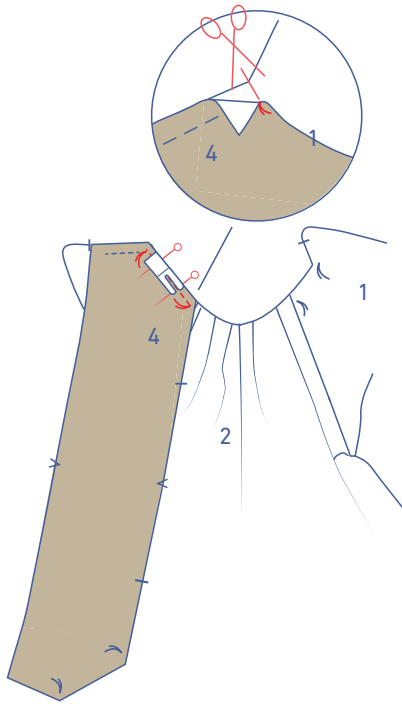

Turn the garment to sew the collar to the garment neckline, and then lower the presser foot back down. Sew up to the next marking thread in the corner. The collar's single notches match the shoulder seams, and the V-notch marking the centre of the collar lines up with the CB seam. Repeat the steps above to sew the other side of the collar, stopping $\frac{3}{8}$ " before the end of the collar.

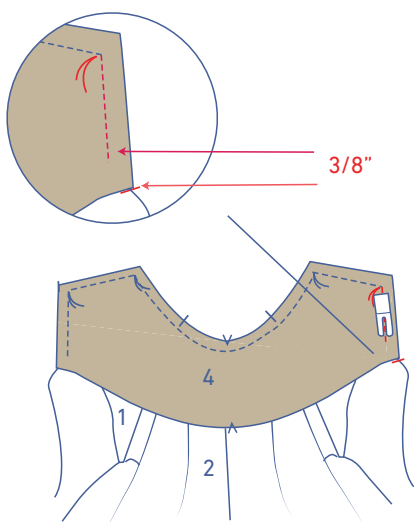
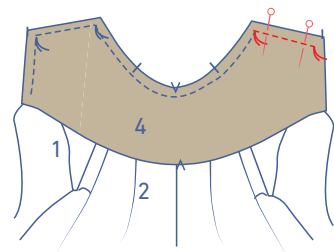
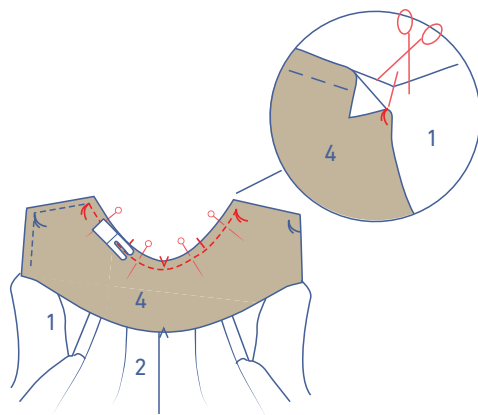

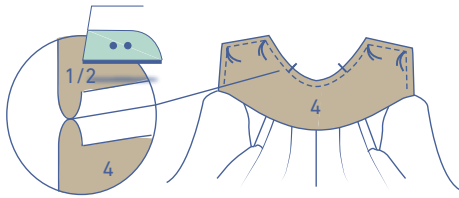

Press the seam allowance open. Notch the seam allowance of the collar (to reduce bulk) and clip the seam allowance of the waistcoat's neckline (to allow the collar to lie properly later).

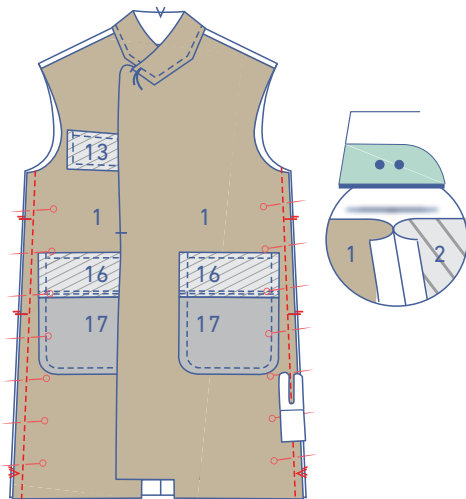
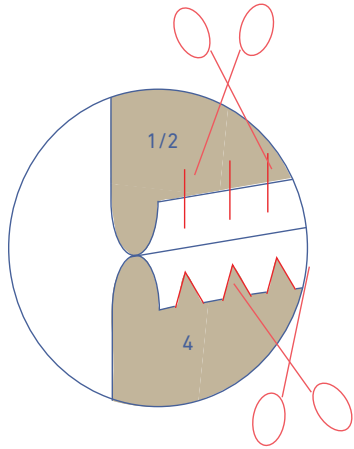

6

Pin and sew the side seams. Press the seam allowance open.

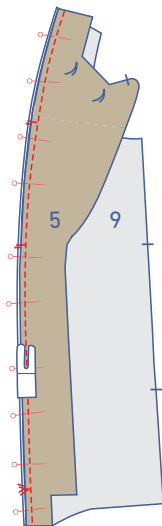

7

Pin and sew the facing front (5) to the front lining (9), matching the notches.

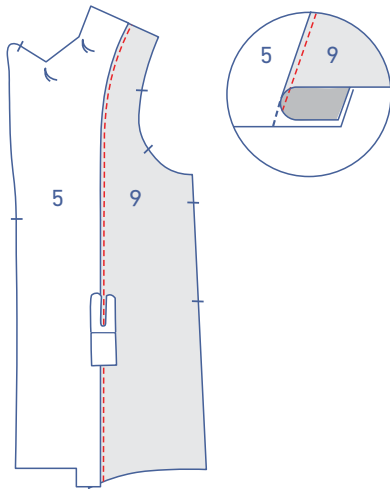

Fold the seam allowance towards the lining. Sew the lining right next to the seam, anchoring all layers (lining + underlying seam allowance).

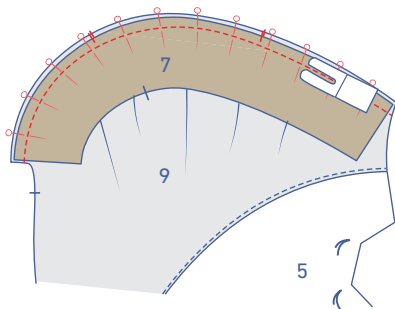

Pin and sew the front armhole facing (7) to the front lining, matching the notches.

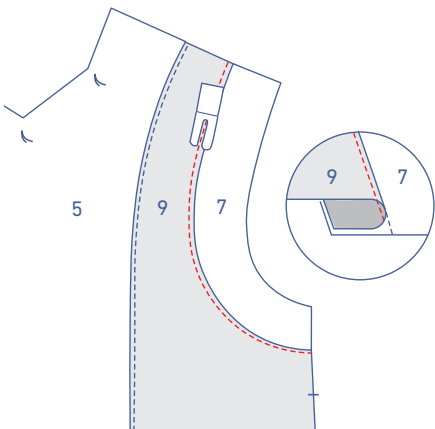

Fold the seam allowance towards the lining. Sew the lining right next to the seam, anchoring all layers (lining + underlying seam allowance).

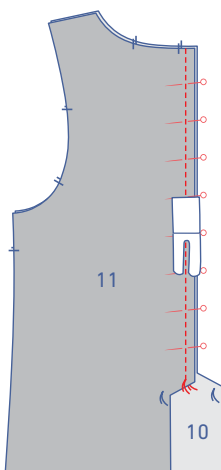

Pin and sew the CB seam of the RB lining (10) and LB lining (11) pieces together from the neckline to the top marking thread.

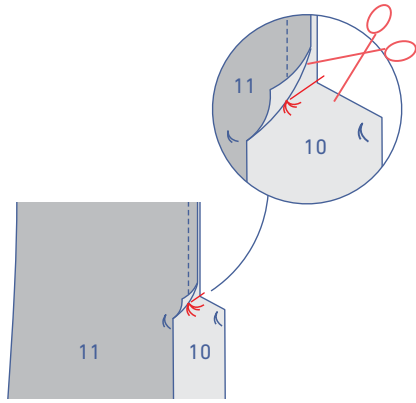

Leave the needle lowered into the fabric there. Raise the presser foot and fold over the corner of the LB lining. Snip into the seam allowance of the RB, stopping just before the needle.

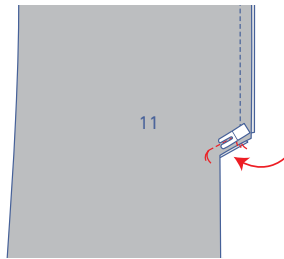

Turn the garment to realign the raw edges and then lower the presser foot back down. Continue sewing to the next marking thread.

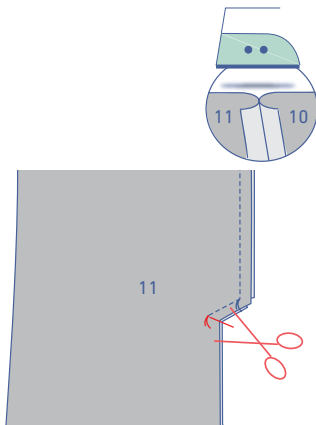

Clip diagonally into the seam allowance of the LB lining to just before the stitching. Press the seam allowance above the top marking thread open.

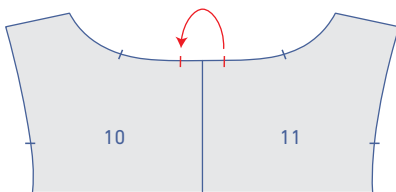

Create a pleat in the CB by matching the notches closest to the CB with the right sides of the fabric touching. Sew a line about 1 1/4" long, parallel to the CB line.

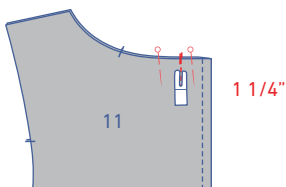

Fold the pleat in the direction indicated and sew into place at presser foot width from the raw edge.

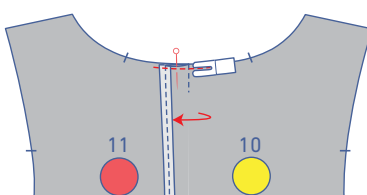

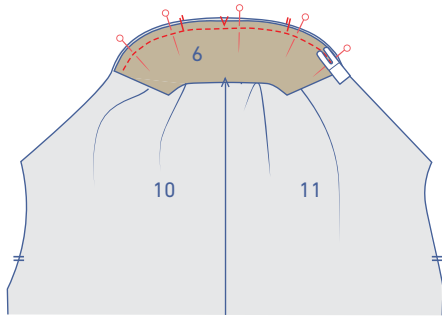

Pin and sew the bottom of the back facing (6) to the top of the back lining, matching the notches.

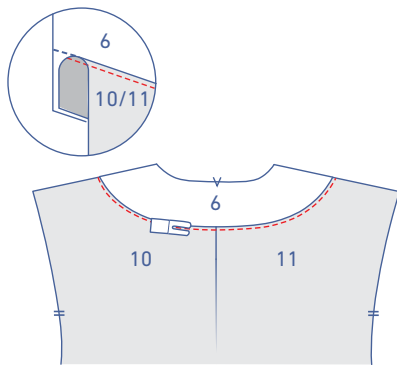

Fold the seam allowance towards the lining. Sew the lining right next to the seam, anchoring all layers (lining + underlying seam allowance).

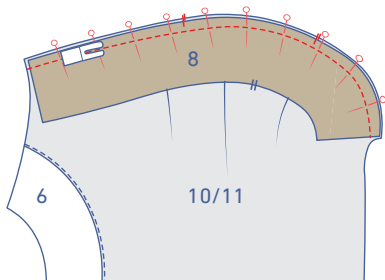

Pin and sew the back armhole facing (8) to the back lining, matching the notches.

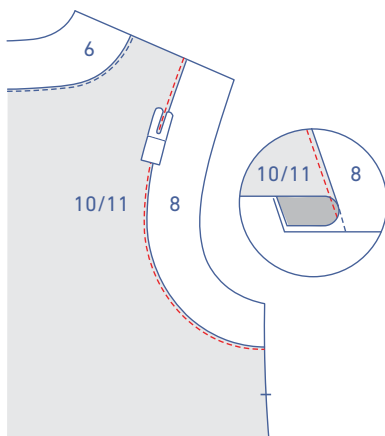

Fold the seam allowance towards the lining. Sew the lining right next to the seam, anchoring all layers (lining + underlying seam allowance).

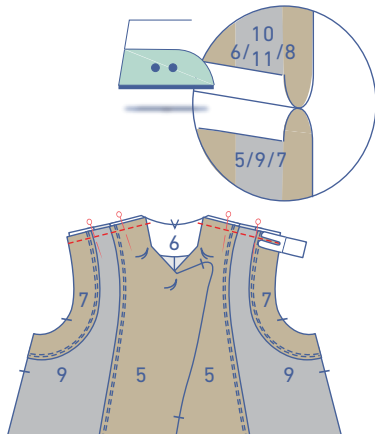

Pin and sew the shoulder seams. Press the seam allowance open.

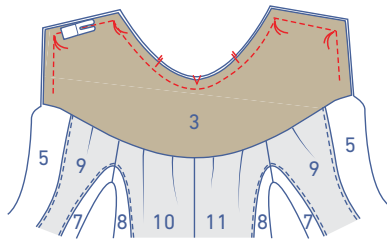

Now, follow the instruction in step 5 to join the upper collar (3) to the waistcoat lining.

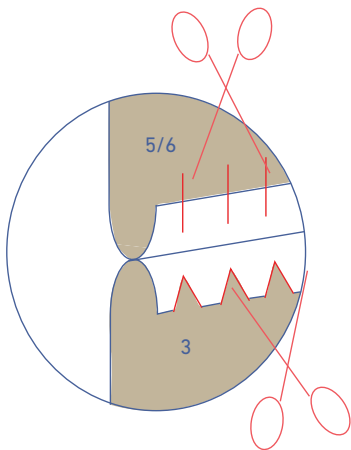

Notch the seam allowance of the collar and clip the seam allowance of the neckline of the waistcoat lining.

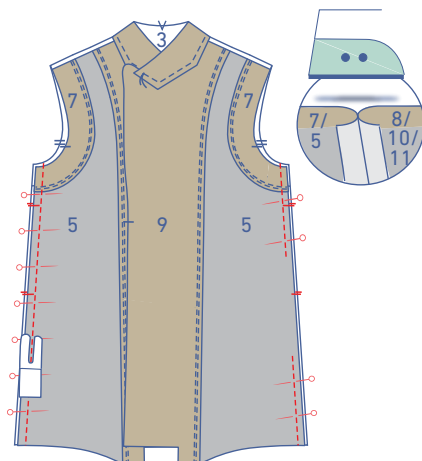

Pin and sew the side seams of the waistcoat lining, but make sure to leave an opening in one of the side seams to turn the waistcoat the right way out later. Press the seam allowance open.

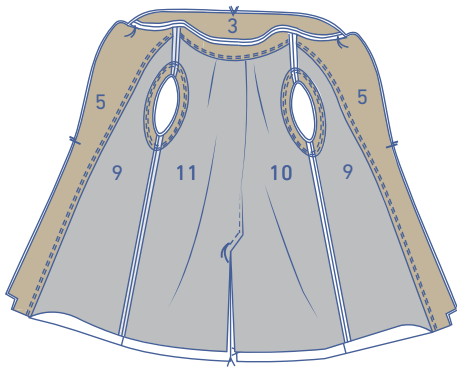

8

Match the right sides of the waistcoat and waistcoat lining.

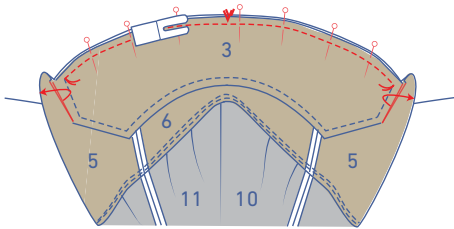

Pin the upper and undercollar together (the undercollar is smaller than the upper collar, so stretch the contours to match). Sew between marking threads, folding the seam allowances of the lapels out of the way as you go.

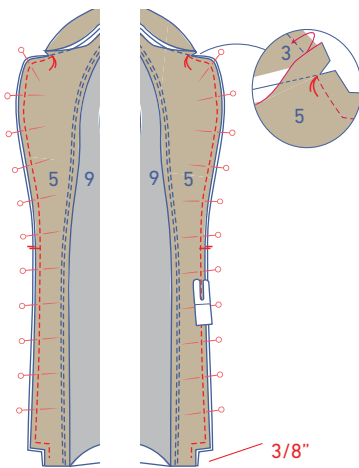

Now, pin the lapels and CF lines together and sew. Start sewing from the marking thread at the intersection of the collar and lapels and stop $\frac{3}{8}$ " before the raw edges of the hem. Fold the seam allowance of the collar out of the way so you can sew from the marking thread.

Trim the seam allowance at the curves and corners.

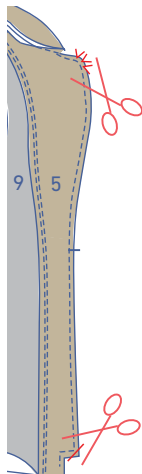

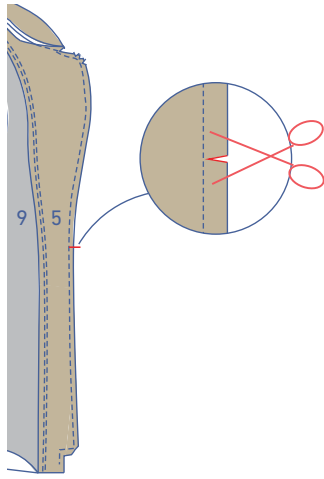

Clip the seam allowance of the lapel at the single notch just up to the stitching.

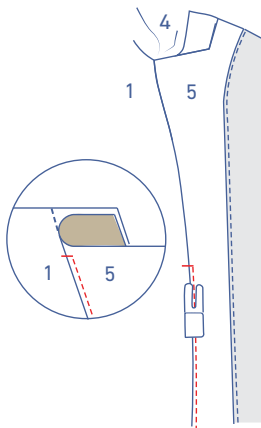

Turn the waistcoat the right way out. Fold the seam allowance at the facing underneath the notch so it seam allowance points towards the facing. Sew the facing to the seam allowance underneath, right next to the seam from the hem to the single notch. This creates nice, clean lines, and it prevents the seam from tending to roll or curl over.

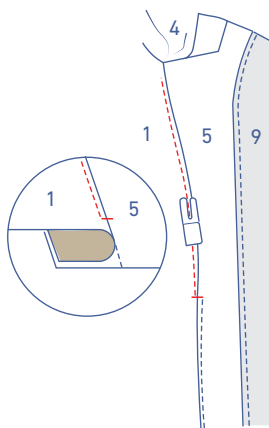

Now, fold the seam allowance above the notch towards the front and sew the front to the seam allowance underneath. Start at the notch and sew as far as possible.

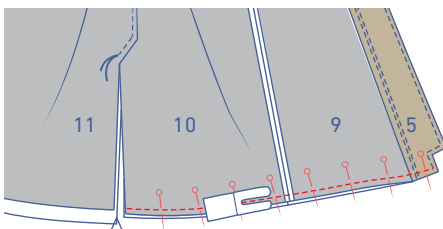

9

Turn the waistcoat the wrong way out again. Pin the hem of the RF + RB and the RF lining + RB lining together with the right sides touching. Sew into place.

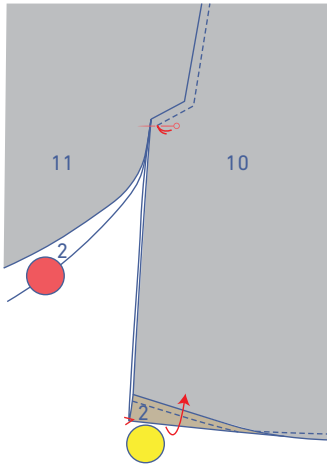

Pin the marking threads above the slit of the RB and RB lining together. Turn the hem allowance of the RB up at the V-notch with the right sides touching.

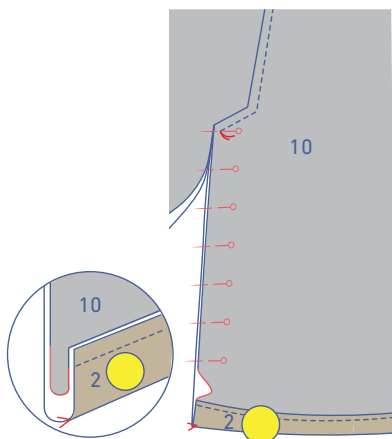

Now, pin the slit in the waistcoat lining to the main fabric waistcoat from the marking thread towards the hem. The waistcoat lining slit is longer than the main fabric waistcoat so you will need to slightly pleat the waistcoat lining slit to make both ends the same length. The excess waistcoat lining can be neatly tucked between the waistcoat and the hem allowance of the waistcoat.

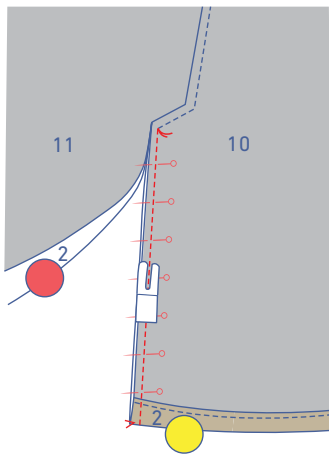

Sew into place between the marking thread and the hem.

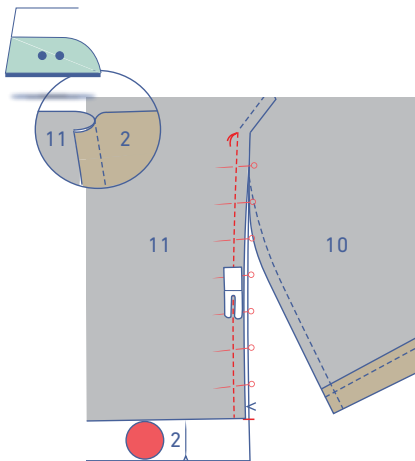

Now, pin the LB slit to the LB lining slit, matching the marking threads. The bottom of the lining slit matches the single notch in the edge of the LB. Sew together from the marking thread to the bottom of the lining. Press the seam allowance towards the lining.

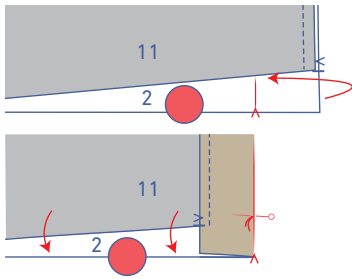

Fold the slit facing of the LB over at the pressed fold line with the right sides of the fabric touching. Now, match the hems of the LF+LB and the LF lining + LB lining and pin. You will need to tug the facing at the slit at an angle to properly align the edges. Tip: the marking thread must remain on the edge. Make sure it doesn't curl onto the inside.

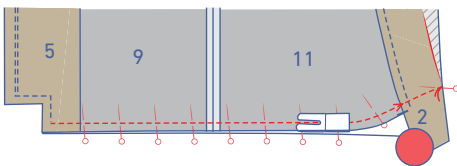
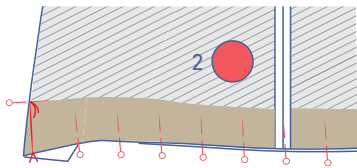
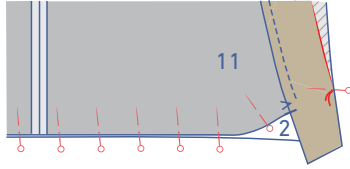

Now, sew the main fabric waistcoat and lining waistcoat hems together from the marking thread on the edge. Sew in a curved line towards the V-notch until you are left with $\frac{3}{8}$ " of seam allowance. Continue sewing towards the CF.

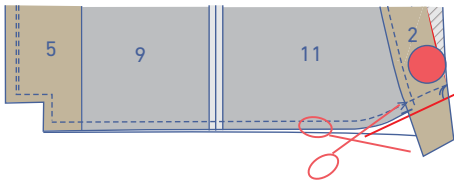

Neatly clip the LB slit at an angle.

10

Turn the waistcoat the right way out.

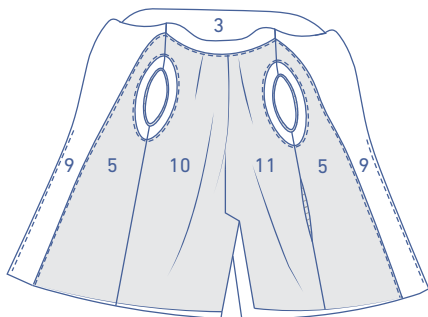

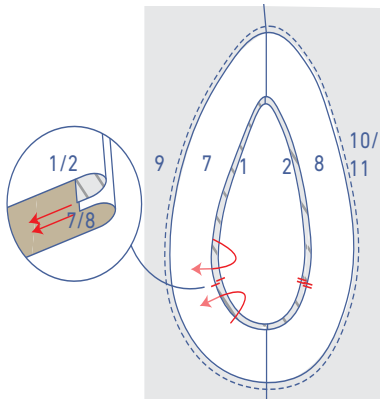

Neatly align the waistcoat armholes with the waistcoat lining armholes. Firmly take hold of the armholes and pull them through the opening in the side seam.

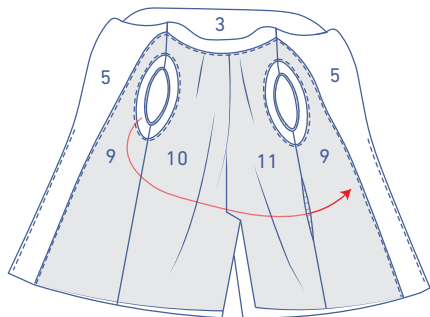

Now, fold the seam allowances of the waistcoat and waistcoat lining's armholes together so that the right sides are touching. Match the raw edges of the armholes.

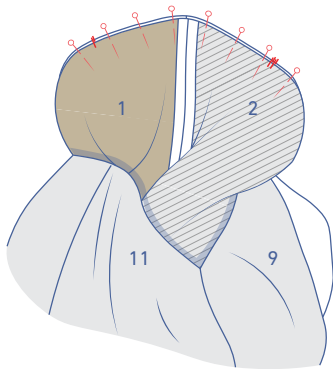

Sew the armholes all the way around. Do this in 1/8" increments: match the raw edges and sew approx. 1/8". Realign the raw edges and sew another 1/8" increment. etc. Continue until you've sewn all the way around.

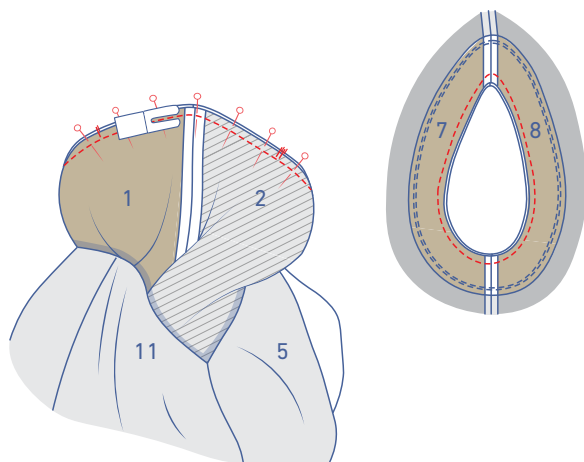

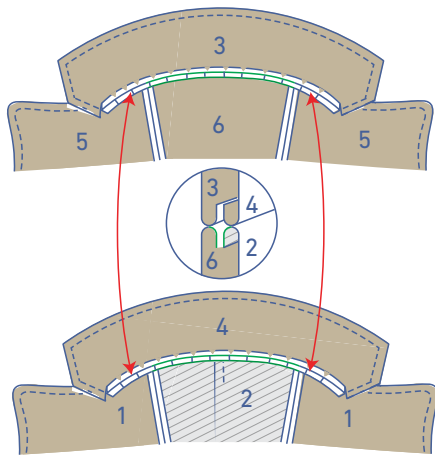

11

Turn the waistcoat the right way out again. Slide your hand through the opening in the side seam and pull the seam allowance of both waistcoat necklines through the opening. Hand sew or stitch the seam allowances together from shoulder to shoulder.

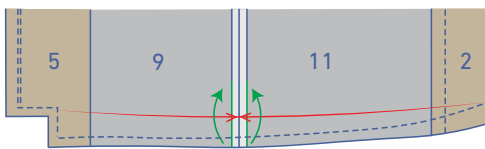

Turn the hem allowance (+ corner of the hem) up and press. Then, match the seam allowances marked with a green line. Slide your hand through the opening in the side seam and pull these points through the opening. Hand sew or stitch the seam allowances together at the side seams.

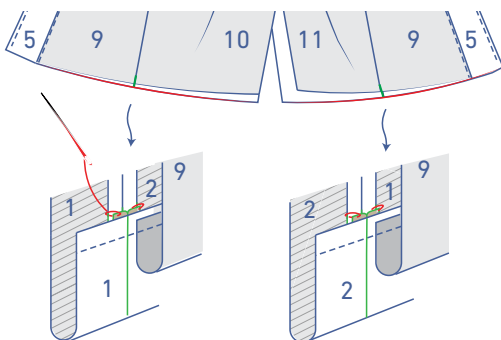
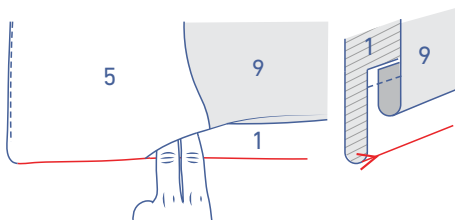
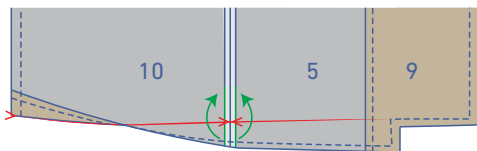

To sew the shoulder pads, slide them through the side seam.

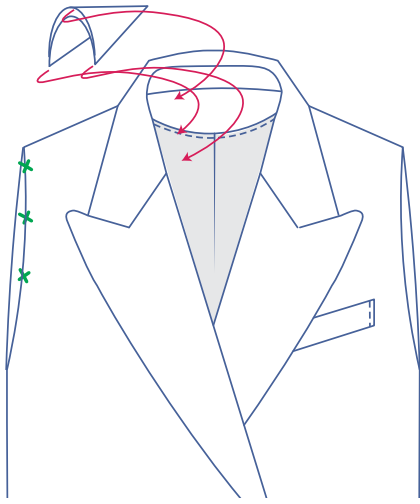

Pass your hand through the opening in the lining. Secure the facing to the side seams with just a few stitches and secure on the inside with some hand stitches where indicated.

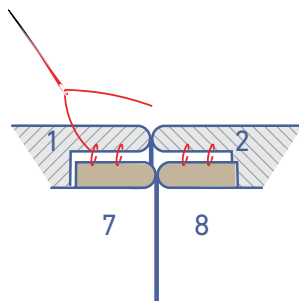
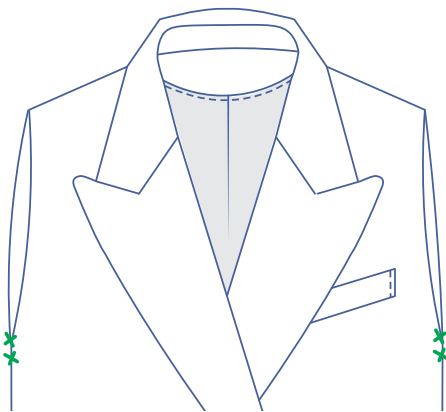

Now, hand sew or stitch the opening in the side seam of the waistcoat lining closed.

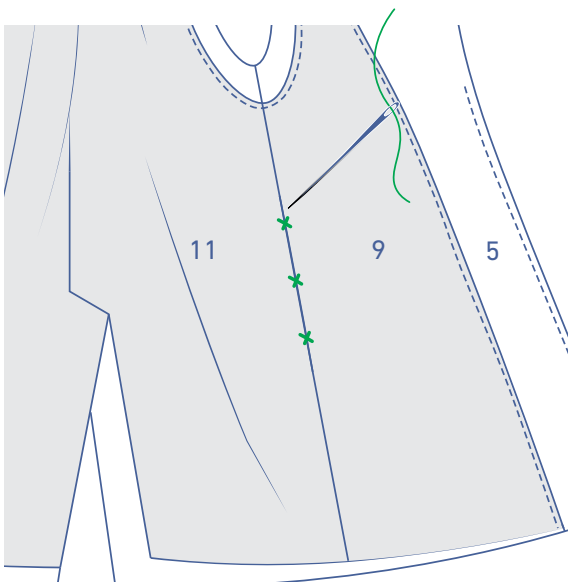

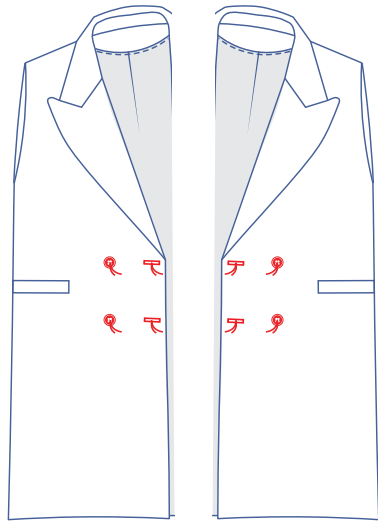

12

Sew the buttons on where indicated. Make horizontal buttonholes to match.

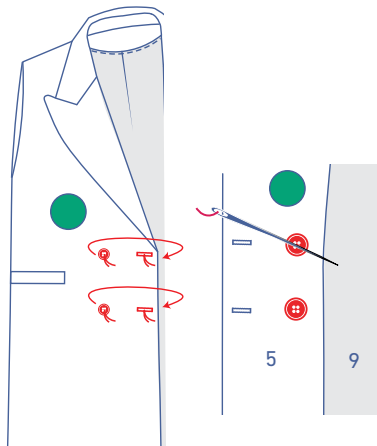

Sew the buttons on where indicated.