



Sasha by Fibre ood

Sasha by Fibre ood



4 - 32

The romantic wins the day with this festive, billowy dress. Sasha's criss cross ties add interest to the back (and it's bra friendly!) Make this dress with or without an elastic waist. And the length? That's also up to you! Ditch the ruffled tiers, and you've got a gorgeous top. Add two tiers or more to increase the length of your dress. The gathers at the top and the deep pleats at the sleeve trim turn up the flair. Sleeve trim gives the slightly puffed sleeves the perfect drape. Our faithful Sewist(a)s are bound to catch a hint of the [Doris dress](#) and [Marion dress](#) in this design.

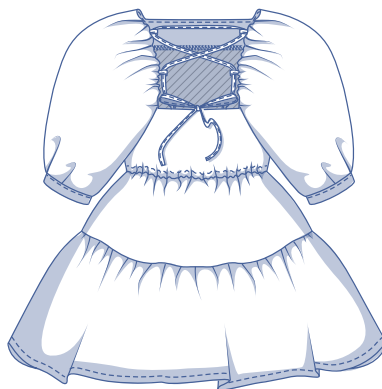
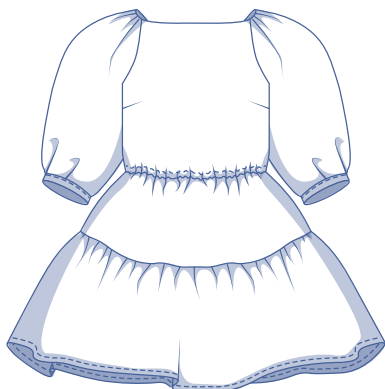
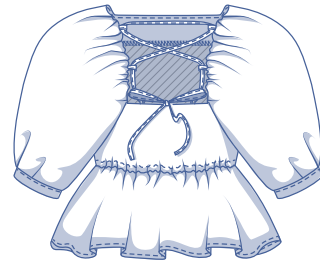
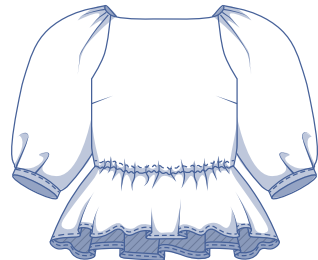
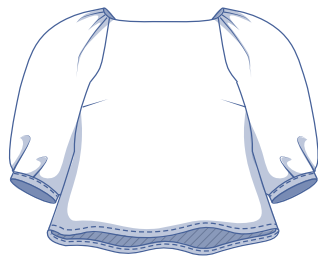

size chart (in cm)

size	4	6	8	10	12	14	16	18	20	22	24	26	28	30	32
body height	160	164	166	167	168	169	170	171	172	172	172	172	172	172	172
B (bust)	76	80	84	88	92	96	100	104	110	116	122	128	134	140	146

Choose your size based on your **bust measurement**. Pick the size that is the best match for your bust.

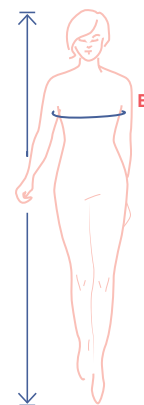

pattern measurements (in cm)

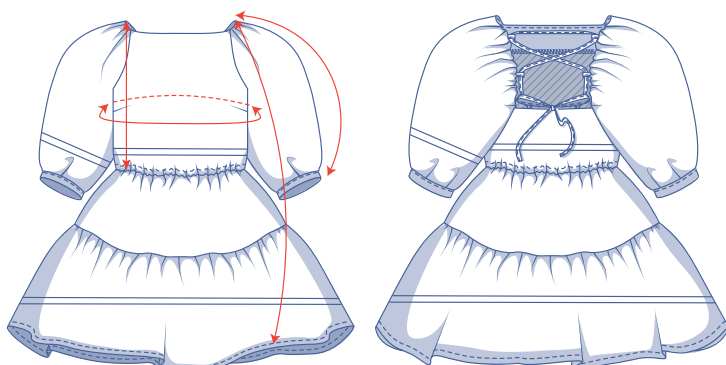

— shorten or lengthen the pattern here

This chart's measurements are the pattern measurements based on the fabric type and serve as a reference. Ease has been added to the width measurements (in addition to the exact body measurements) for a more comfortable fit. Sasha is designed to have a **fitted bust**.

size	4	6	8	10	12	14	16	18	20	22	24	26	28	30	32
dress length	87.75	88.25	88.75	89.5	90	90.5	93	93.5	97.5	98.25	99	99.75	100.5	101.5	102.25
top length*	54.5	55.25	56	56.75	57.5	58.25	59	59.75	60.75	61.75	62.75	63.75	64.75	65.75	66.75
sleeve length**	45	45.5	46.25	46.75	47.25	47.75	48.5	49	51.25	52	52.5	53	53.75	54.5	55
bust	84	87.75	91.75	95.5	99.25	103	106.75	110.5	117.25	122.75	128.25	133.75	139.25	144.75	150.25

* Lengthen pattern pieces 1 and 2 to this length to make the top.

** Including cuff.

Compare the stated lengths to the measured or desired lengths. **Lengthen** or **shorten** the dress and/or the sleeves by cutting the pattern pieces at the indicated double lines. Then either increase the distance between the cut pieces by the desired amount (to lengthen) or overlap the pieces (to shorten). Make sure that the CF and CB lines and the side seams are always straight.

IMPORTANT

Adjust the amount of fabric to be used based on these alterations.

notions



- Thread
- Iron-on interfacing: max. 35 cm
- Elastic* (width 0.5 cm): see table
- Shoulder strap retainer: 2
- Fabric: see table

elastic*		4	6	8	10	12	14	16	18	20	22	24	26	28	30	32
length	cm	68	70	72	76	80	84	86	90	96	103	109	116	122	129	135

* The elastic's stated measurements (including overlap) are merely indicative and depend on the type of elastic. First, take your measurements with the elastic to determine the precise length. Always add 3 cm of overlap to your measurements.

fabric use dress		4	6	8	10	12	14	16	18	20	22	24	26	28	30	32
fabric width 110 cm	cm	295	295	300	300	305	305	340	345	365	375	390	400	415	425	440
fabric width 140 cm	cm	255	260	265	285	290	290	300	300	320	325	325	330	340	345	355

The corresponding fabric layout can be found on page 6 of these sewing instructions.

fabric use top		32	34	36	38	40	42	44	46	48	50	52	54	56	58	60
fabric width 110 cm	cm	245	250	255	255	260	265	265	270	275	280	285	290	290	295	300
fabric width 140 cm	cm	220	230	235	240	245	250	255	260	270	275	280	285	290	295	300

fabric advice



Sasha looks a treat in all kinds of fabrics, from a light and fluid drape to stiff and somewhat heavier fabrics. Whether you go for a soft drape or fabric with more body depends on the look you're going for. Drama lovers? Choose something with a little more oomph, e.g. poplin. Are you after subtle charm? Soft drape materials with little to no texture, e.g. viscose (crepe), lyocell, and satin, are all good options. A solid or a print? Sasha can handle anything.

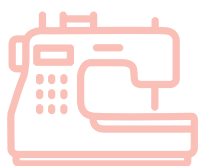

Sewing
MENDS
THE
soul



pattern pieces & seam allowances (in cm)

To sew the garment as described in the instructions, draw the illustrated seam allowances around the paper pattern pieces before cutting them out. If you are using a PDF pattern, the pattern can be printed with or without seam allowance. To find out more, watch the [video](#).

- | | |
|------------------------------------|-------------------------------------|
| 1. front: 1x on fabric fold | 7. skirt front A: 1x on fabric fold |
| 2. back: 1x on fabric fold | 8. skirt front B: 1x on fabric fold |
| 3. sleeve: 2x | 9. skirt back A: 1x on fabric fold |
| 4. cuff: 2x | 10. skirt back B: 1x on fabric fold |
| 5. facing front: 1x on fabric fold | 11. loops: 1x |
| 6. facing back: 1x on fabric fold | 12. tie: 1x on fabric fold |

Important!

Pattern pieces '7 and 9' and '8 and 10' are the same pieces.

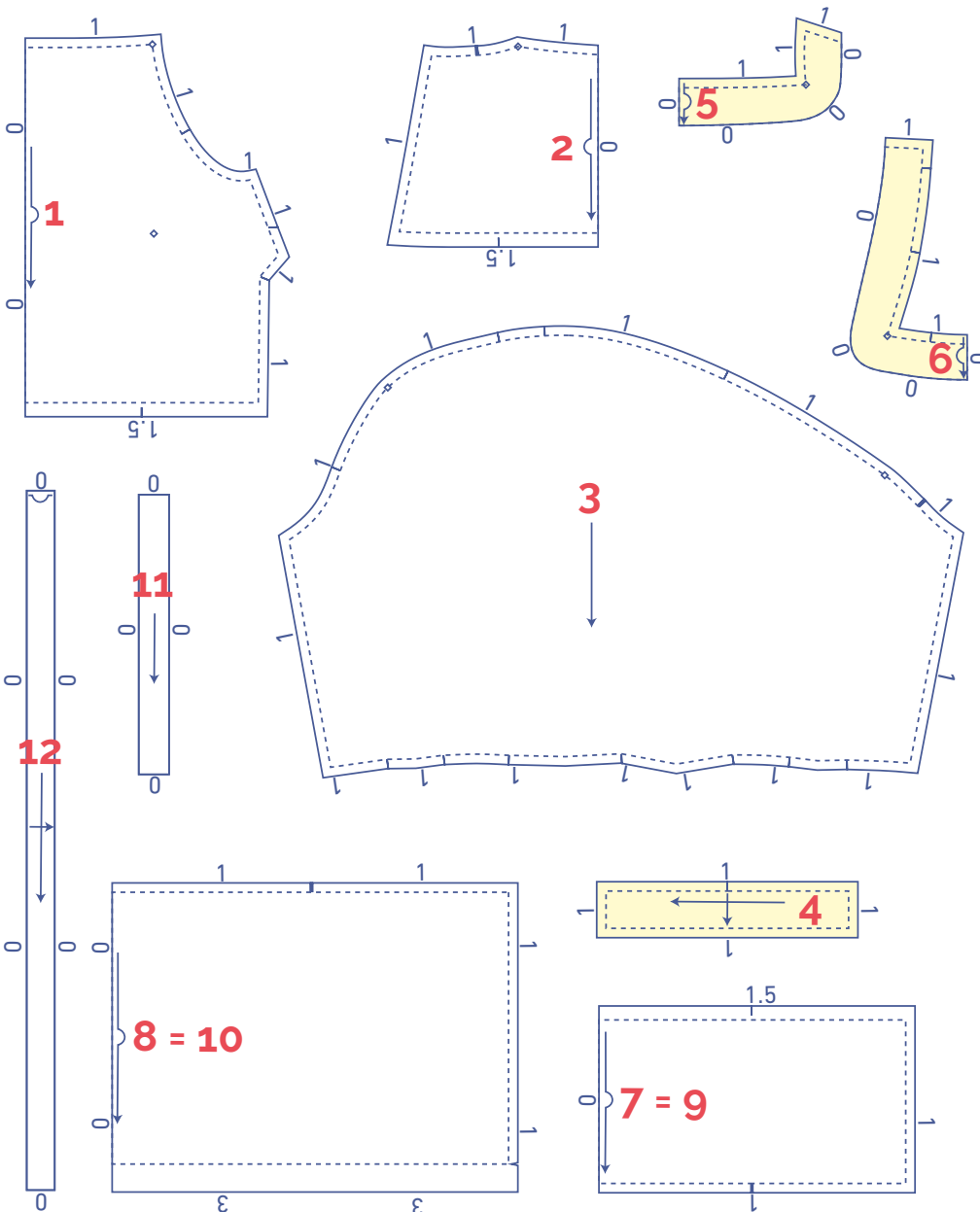

	material type
	fabric
	iron-on interfacing

TIP

To make the top, lengthen pattern pieces 1 and 2 to your preferred length and add 3 cm of hem allowance. The top omits pattern pieces 7 through 10.

To make a peplum top add 3 cm hem allowance to pattern pieces 7 and 9 to finish the top as shown in the sewing instructions. You don't need pattern pieces 8 and 10.

If you are making the dress, you can add an extra ruffled tier at the bottom. Measure the circumference of the skirt front B and skirt back B. Add 30%. Draw a rectangle to this length and the desired width. Add 1 cm of seam allowance to the bottom of skirt front B and skirt back B. Add 3 cm of hem allowance to the bottom of the new rectangular strip.

fabric layout – solid fabrics
fabric width 110 cm

4 - 14

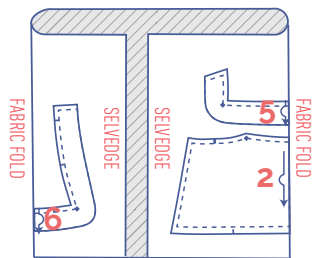
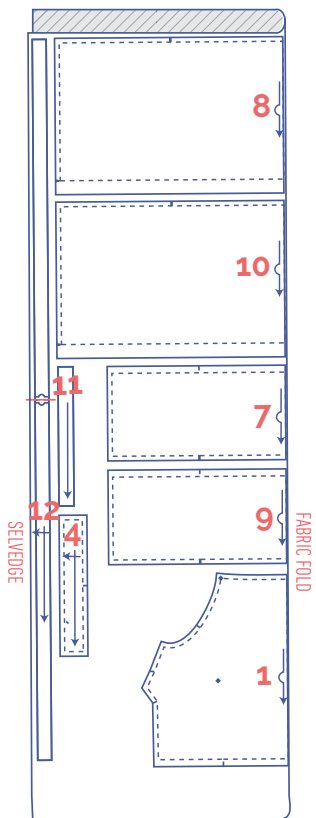

+

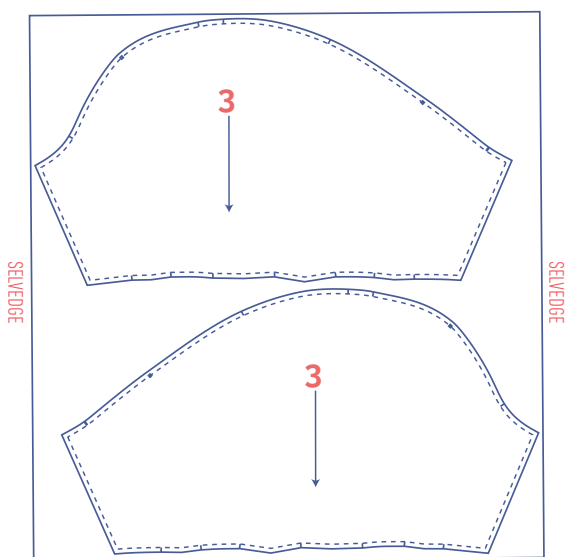

16 - 18

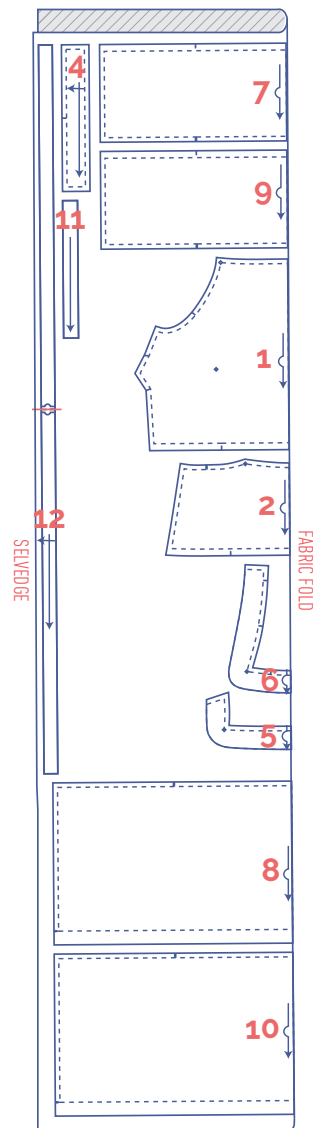

+

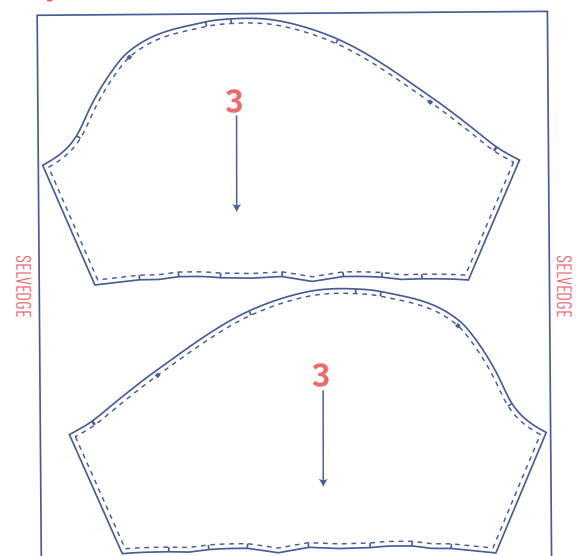

Important!

Because the fabric is opened out as a single layer, you need to cut mirror images of pattern piece 3 so you have a left and a right sleeve.

You only need pattern piece 11 once.

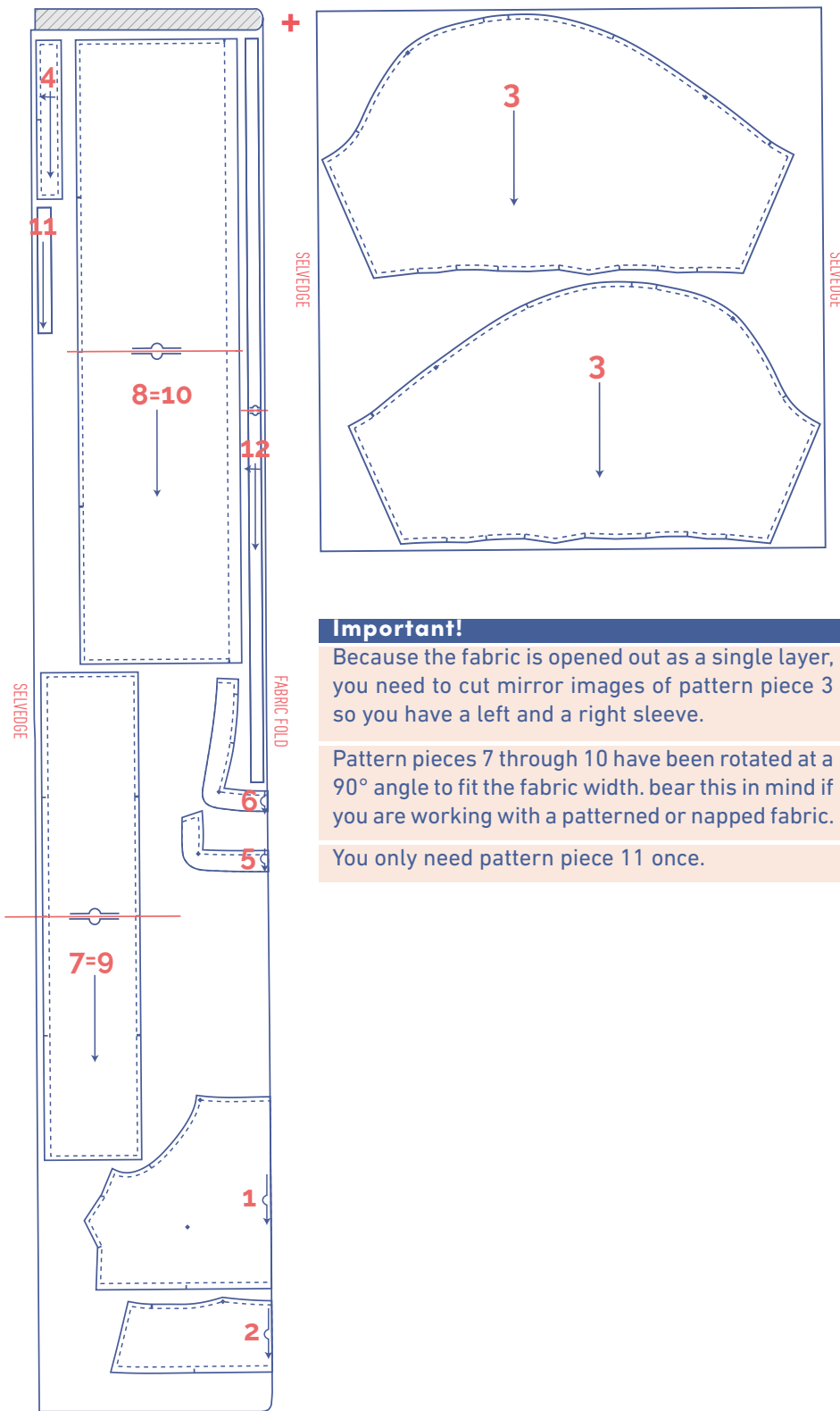

Important!
 Because the fabric is opened out as a single layer, you need to cut mirror images of pattern piece 3 so you have a left and a right sleeve.
 Pattern pieces 7 through 10 have been rotated at a 90° angle to fit the fabric width. bear this in mind if you are working with a patterned or napped fabric.
 You only need pattern piece 11 once.

marking pattern pieces

	Notch the pattern paper and fabric at the following points
	single notch
	double notch
∨	V-notch/fabric fold

	Mark the following centre points with marking thread
	centre point

fabric layout – solid fabrics fabric width 140 cm

4 - 8

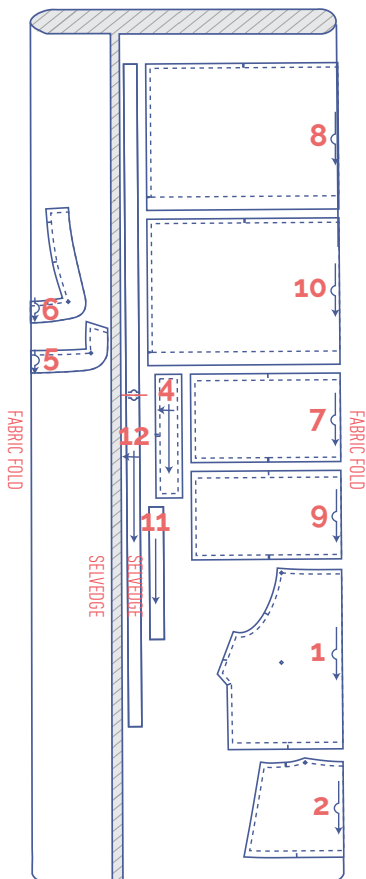

+

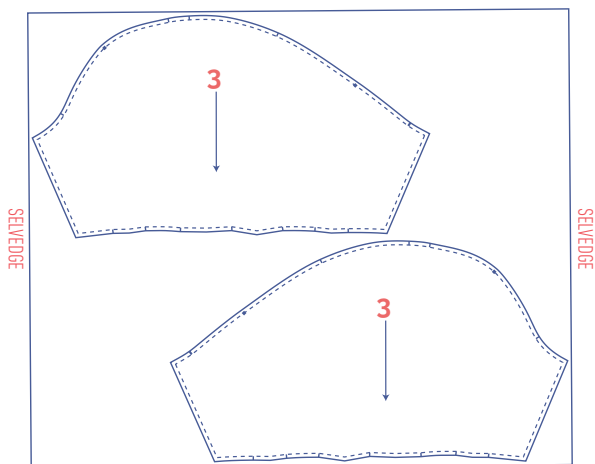

Important!

Because the fabric is opened out as a single layer, you also need to cut-to-mirror pattern piece 3. That's because you need a left and a right sleeve.

You only need pattern piece 11 once.

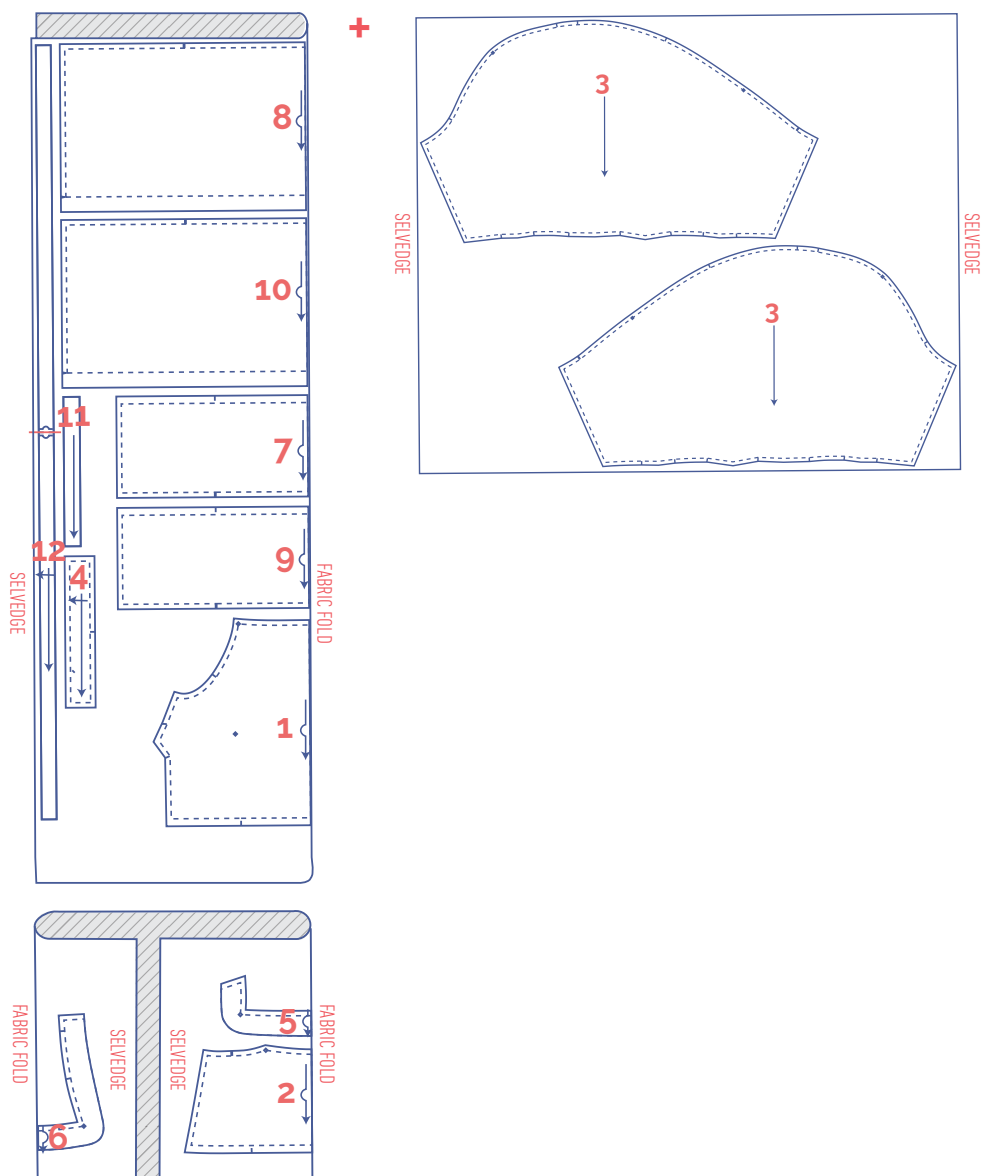

Important!





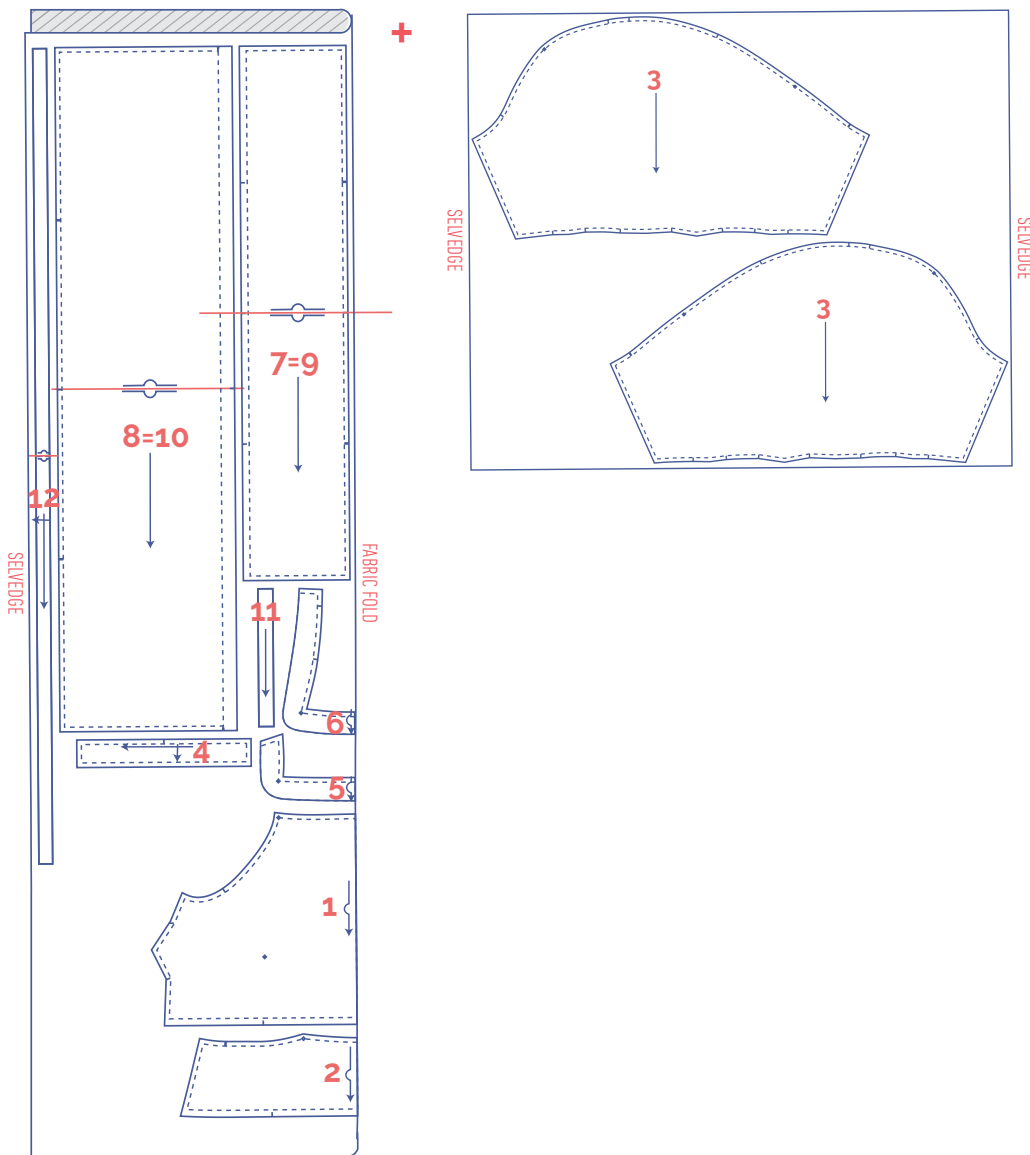

Because the fabric is opened out as a single layer, you also need to cut mirror images of pattern piece 3 so you have a left and a right sleeve.

You only need pattern piece 11 once.



Important!
 Because the fabric is opened out as a single layer, you also need to cut mirror images of pattern piece 3 so you have a left and a right sleeve.
 Pattern pieces 7 through 10 have been rotated at a 90° angle to fit the fabric width. Bear this in mind if you are working with a patterned or napped fabric.
 You only need pattern piece 11 once.

marking pattern pieces

 <p>Notch the pattern paper and fabric at the following points</p>	 <p>Mark the following centre points with marking thread</p>
 <p>single notch</p>	 <p>centre point</p>
 <p>double notch</p>	
 <p>V-notch/fabric fold</p>	

sewing instructions



The method used to finish the seams depends on the fabric used. The pieces are always sewn together with the right sides of the fabric facing, unless stated otherwise.

F front

B back



right side



wrong side



iron-on interfacing



elastic

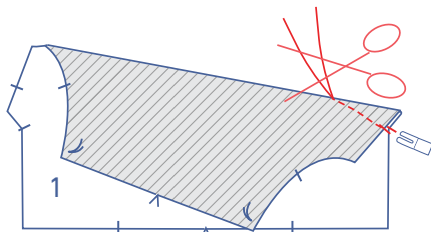
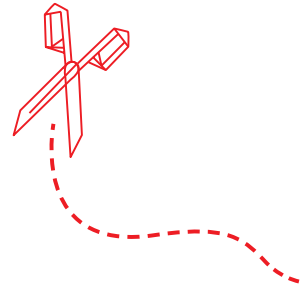

1

Fold the notches in the side seam of the front (1) together with the right sides of the fabric facing. Sew the dart in a slightly curved line towards the marking thread. Sew up to and just past the marking thread so that you sew past the fabric. Snip the threads and tie a knot.

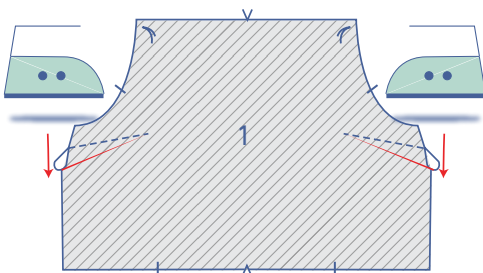

Turn the front over so that the wrong side is facing up. Press the dart downwards.

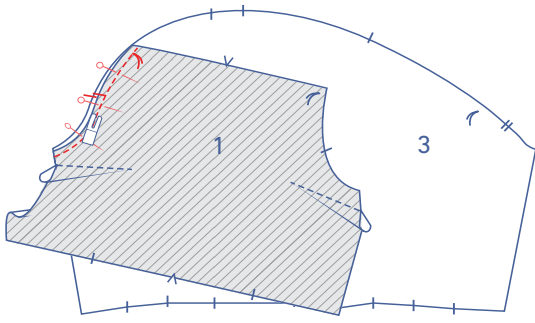

2

Pin and sew the sleeve (3) end with a single notch to the front, matching the markings.

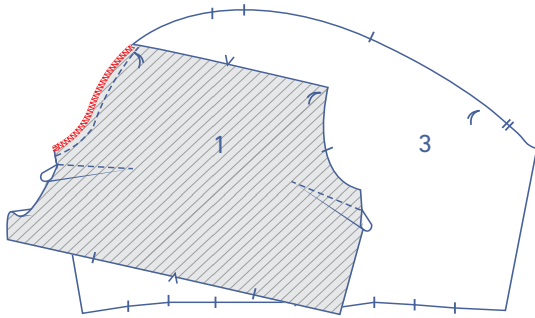

Finish the raw edges with overlock stitching. Press the seam allowance towards the front.

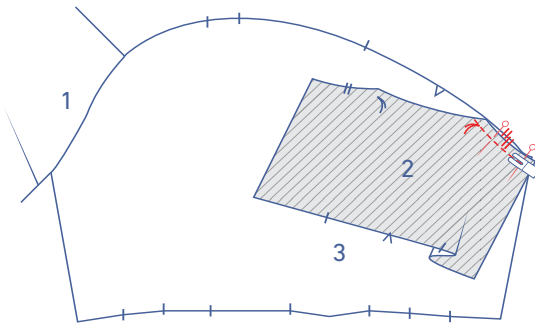
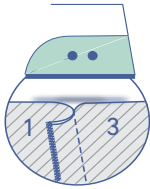

Pin and sew the sleeve end with a double notch to the back (2), matching the markings.

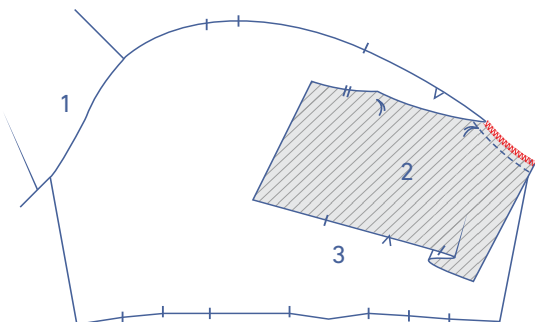

Finish the raw edges with overlock stitching. Press the seam allowance towards the back.

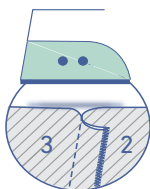

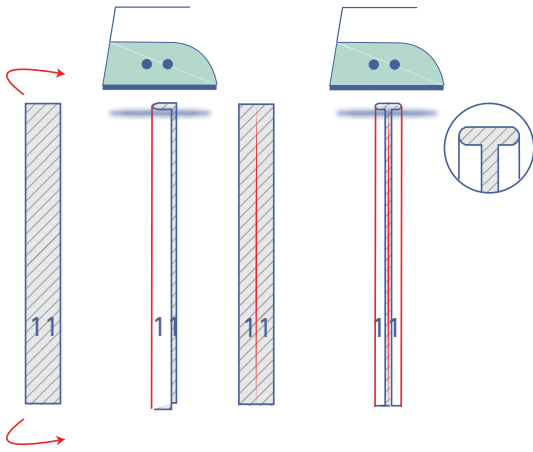

3

Press the loop strip (11) in half with the long ends together and the wrong sides of the fabric touching. Open back out.

Press both raw edges in to the pressed centre line.

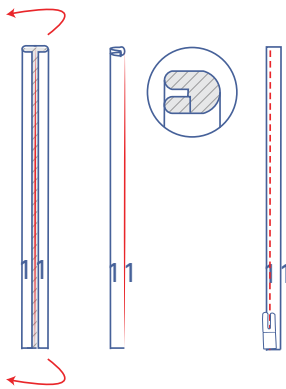

Fold the loop strip in half along the pressed centre line. Edgestitch into place.

Cut into 6 equal pieces.

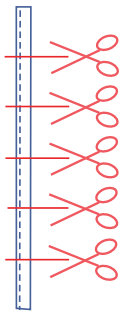

Pin each loop with the ends overlapping to the back facing (6) where indicated. Sew into place at presser foot width from the edge.

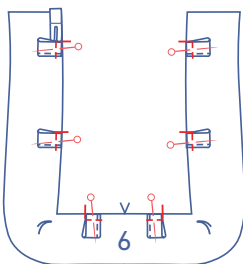

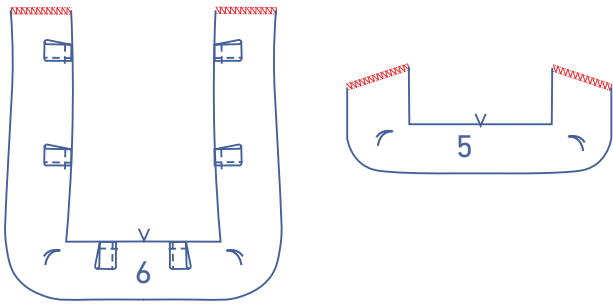

4

Finish the edges of the front facing (5) and the back facing with overlock stitching where indicated.

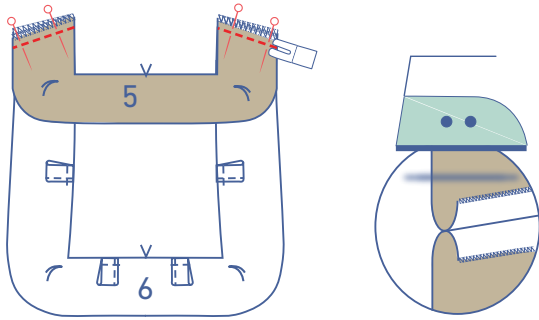

Pin and sew the shoulder seams of both facing pieces. Press the seam allowance open.

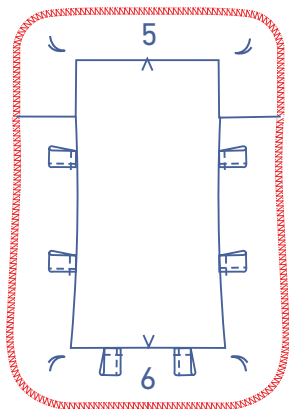

Finish the outer edge of the facing with overlock stitching.

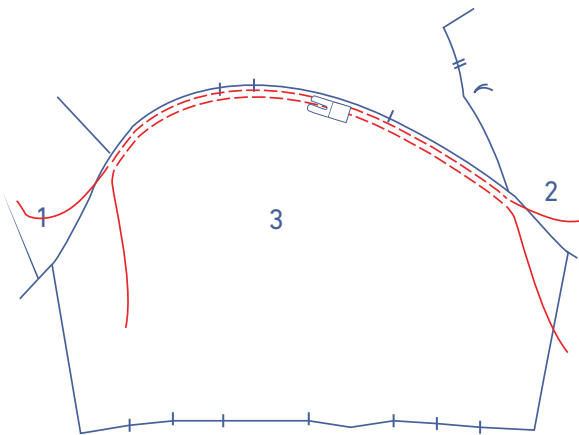

Sew the top of the sleeve with two parallel lines between the front and back seams, using a long stitch length at a low thread tension. Leave a length of thread at the beginning and end of your stitching.

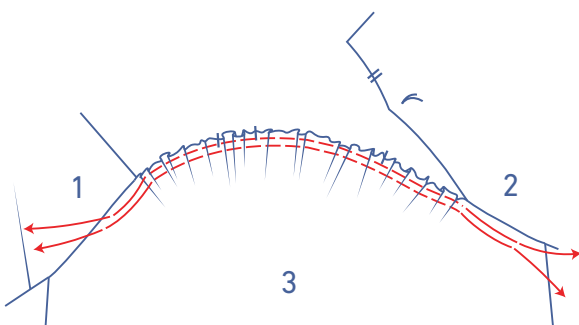

Then, gently tug the gathering threads to gather the fabric.

Pin the facing to the garment. Distribute the gathers, matching markings.

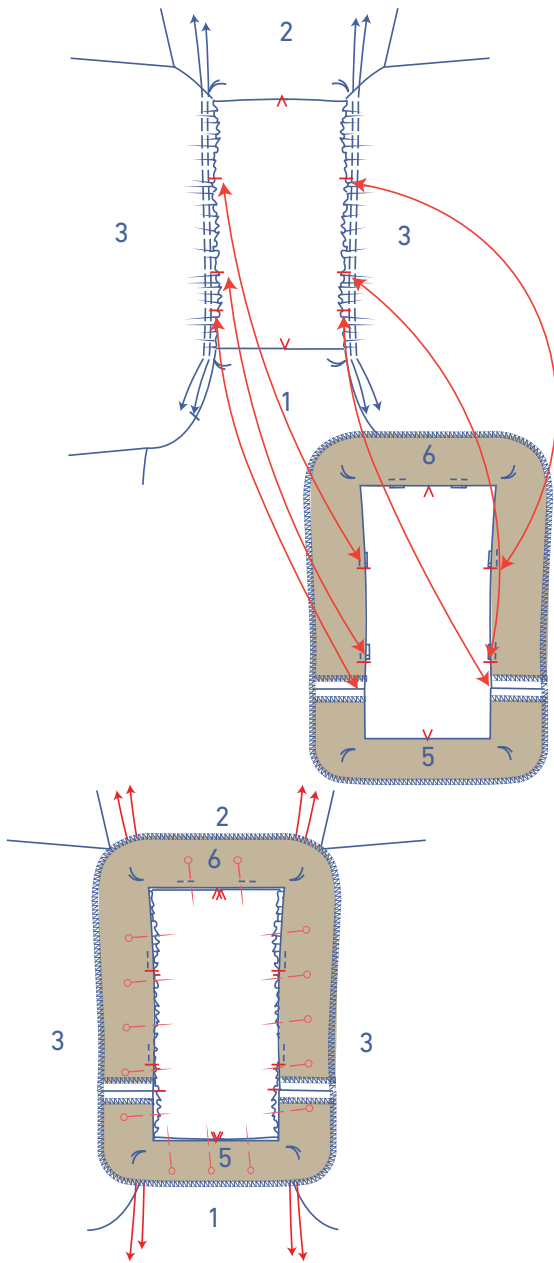

Sew the facing to the garment. Each time you reach a corner (i.e. a marking thread). Leave the needle in the fabric, raise the presser foot and turn the garment. Lower the presser foot back down and continue sewing.

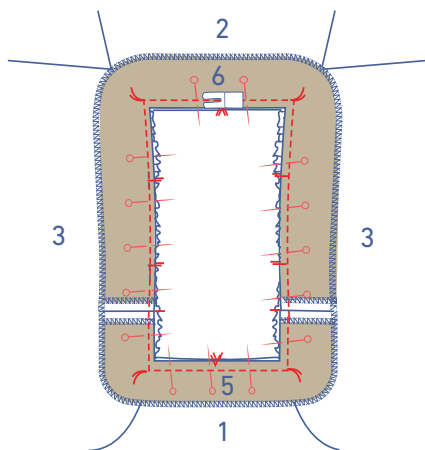

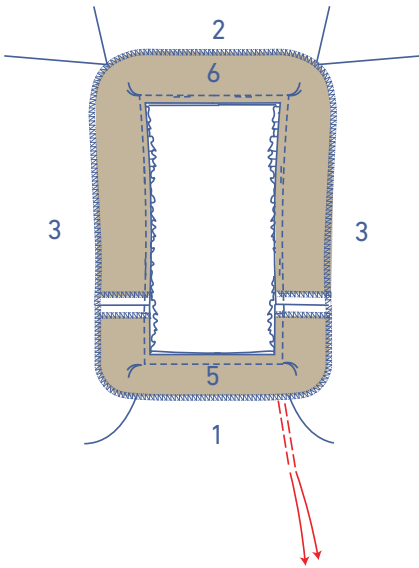

Remove the gathering threads.

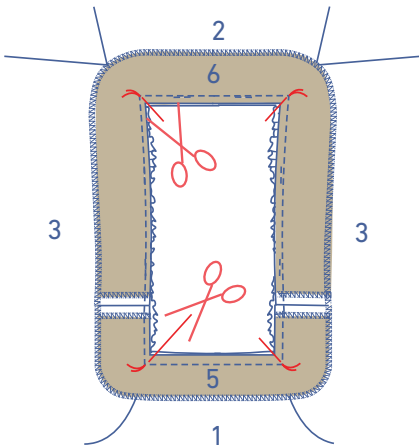

Clip diagonally into the seam allowance at the corners.

Note:

For clean right angles, snip up to the marking threads.

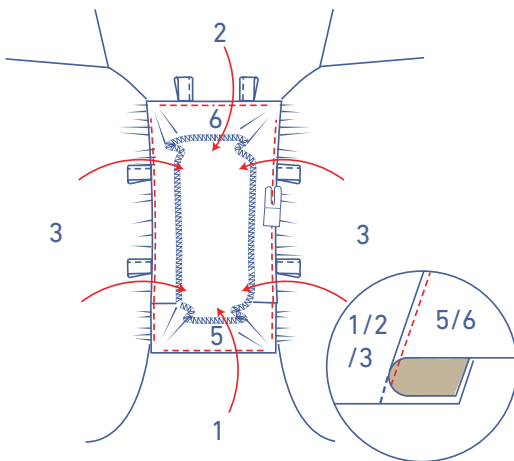

Fold the facing and seam allowance over and sew to the seam allowance underneath, anchoring it right next to the seam. Sew as far as possible towards the corners.

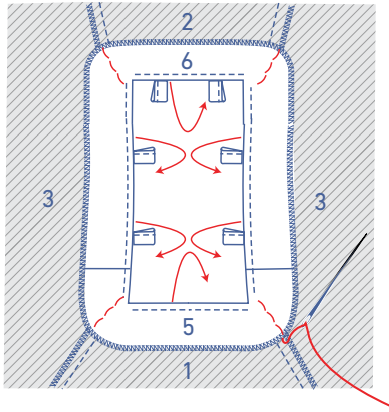

Fold the facing all the way over to the wrong side and secure the corners to the seam allowance with just a few stitches.

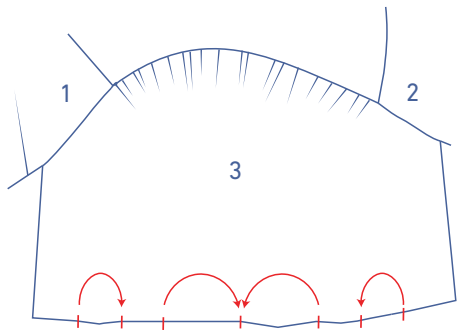

5

Make the sleeve hem pleats by matching the single notches facing the direction illustrated. The wrong sides of the fabric should be touching.

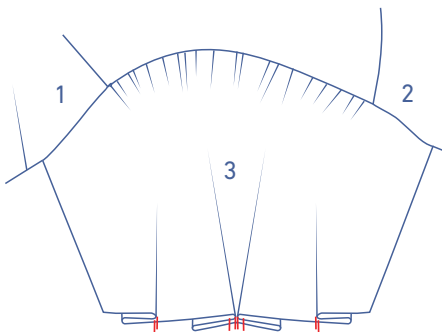

Pin and sew into place at presser foot width from the edge.

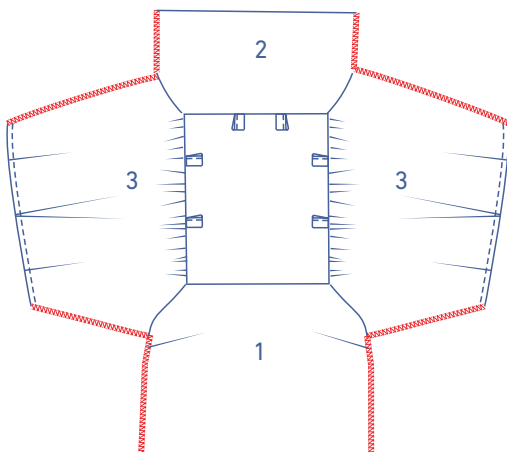
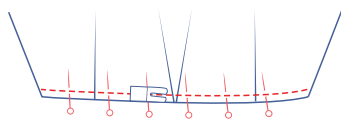

Finish the underarm and side seams with overlock stitching.

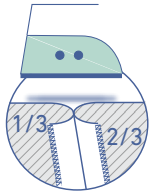
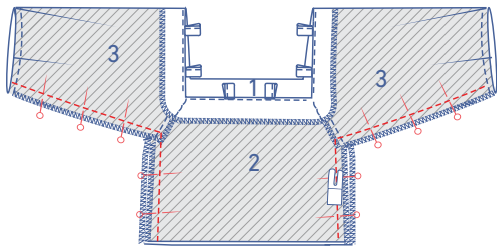

Pin the underarm and side seams together and sew. Press the seam allowance open.

6

Press the cuff (4) in half with the long ends together and the wrong sides of the fabric touching to create a fold line. Open back out.

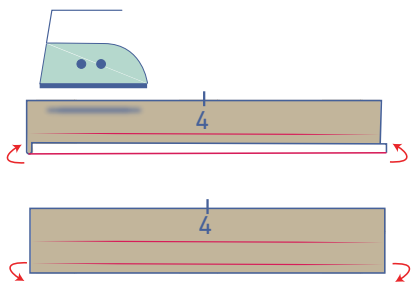
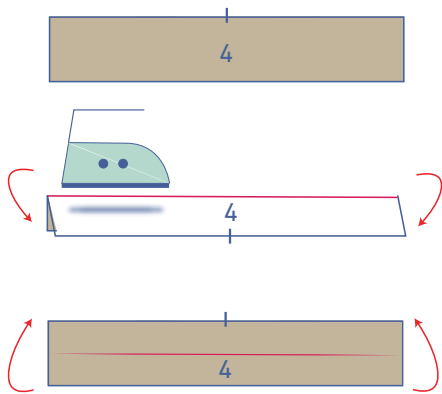

Press the unnotched long end 1 cm towards the wrong side. Open back out.

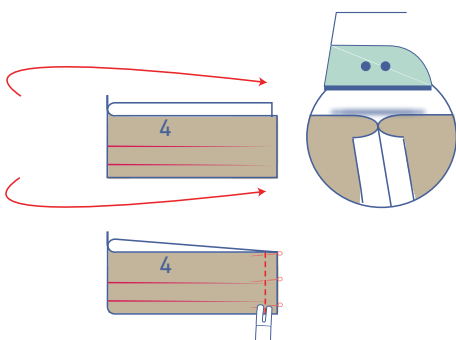

Fold the cuff in half so that the short ends are touching, and the right sides of the fabric are facing each other. Pin and sew the seam. Press the seam allowance open.

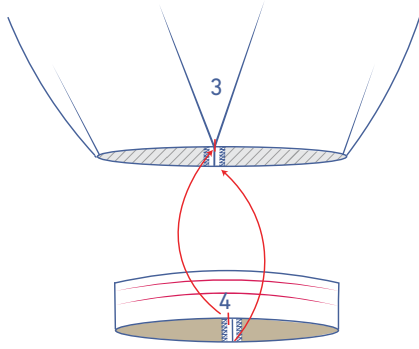

Slide the sleeve over the cuff, pinning the unpressed raw edge of the cuff to the bottom of the sleeve along the wrong side. The notch in the cuff matches the single notch in the middle of the sleeve hem. The right side of the cuff touches the wrong side of the sleeve.

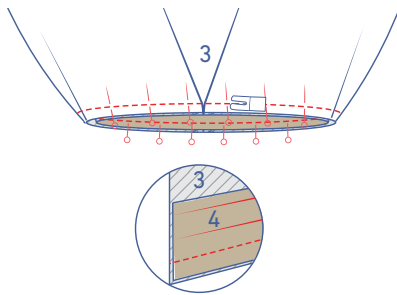

Sew into place.

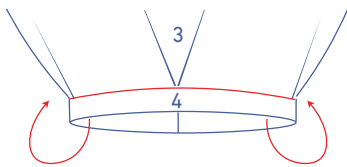

Open the cuff out to the right side of the sleeve and tuck under the raw edge at the fold line. Place the fold line (of the pressed seam allowance) directly over your previous stitching. Edgestitch into place.

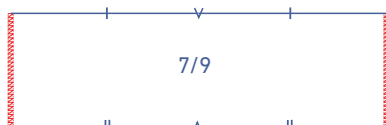
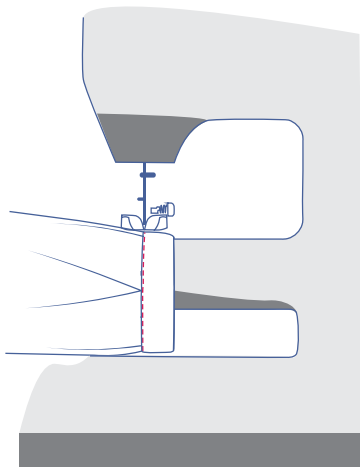

7

Finish the sides of the skirt pieces (7 through 10) with overlock stitching.

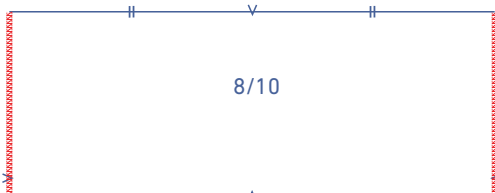

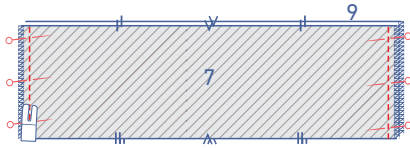

Pin and sew the side seams of the skirt front and back A pieces. Press the seam allowance open.

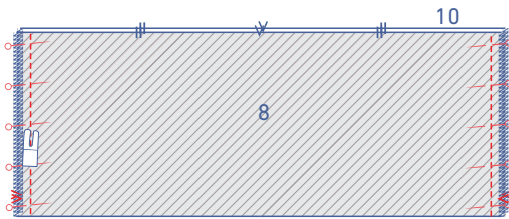
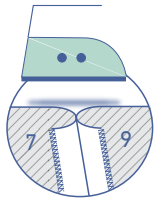

Pin and sew the side seams of the skirt front and back B pieces. Press the seam allowance open.

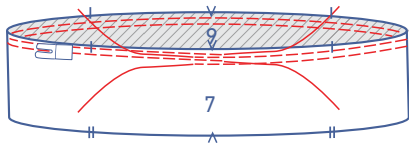
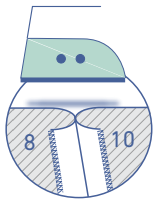

Sew the top of the skirt pieces with two parallel lines, using a long stitch at a low thread tension. Leave a length of thread at the beginning and end of your stitching.

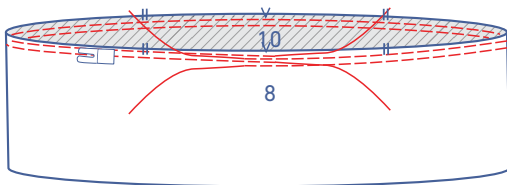

Gently tug the ends of the threads to gather the fabric.

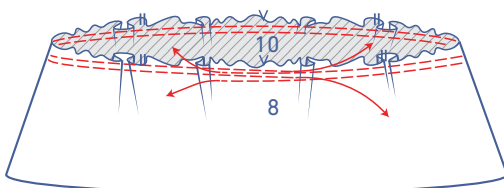
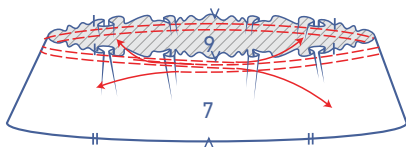

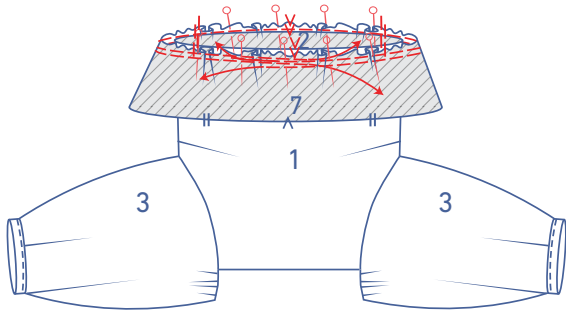

Slide skirt piece A over the bodice and pin, distributing the gathers until the skirt notches match those in the bottom of the bodice.

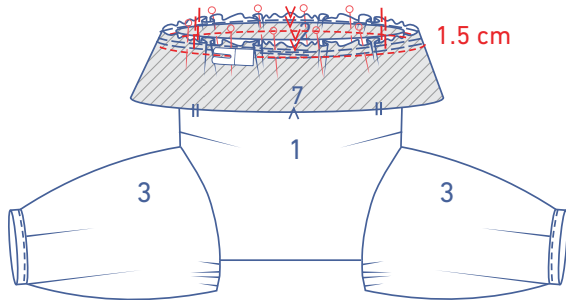

Sew into place with a 1.5 cm seam allowance.

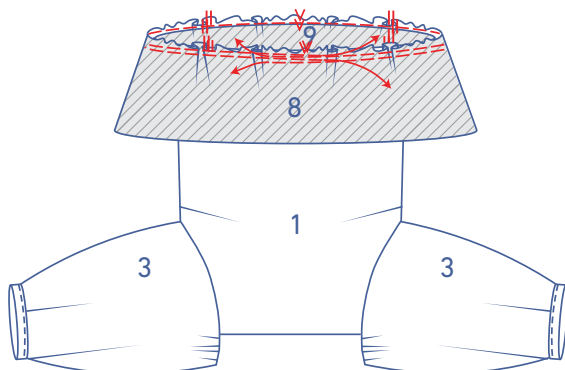

Pin skirt piece B to the bottom of skirt piece A, right sides together, distributing the gathers until the notches in skirt piece B match the ones at the bottom of skirt piece A.

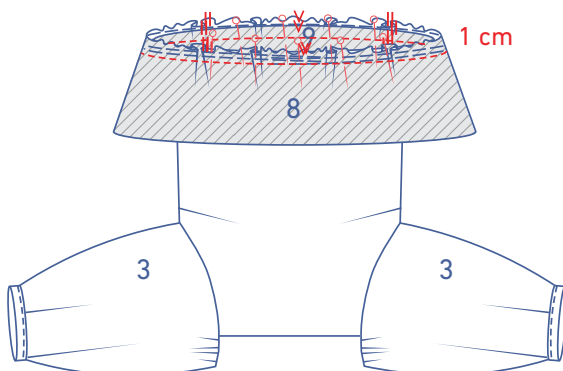

Sew into place at 1 cm.

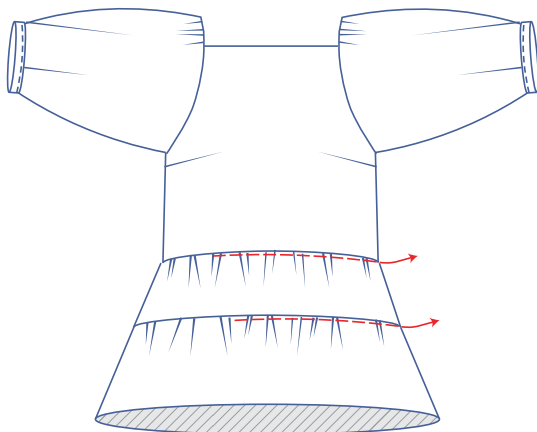

Remove the gathering threads.

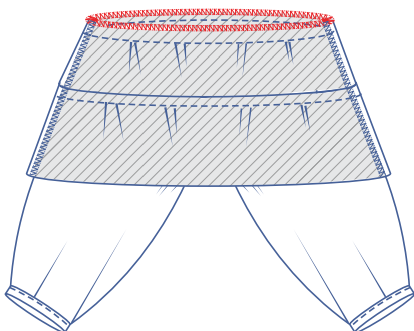

Finish all the raw edges with overlock stitching.

Repeat the previous steps for any additional ruffled tiers.

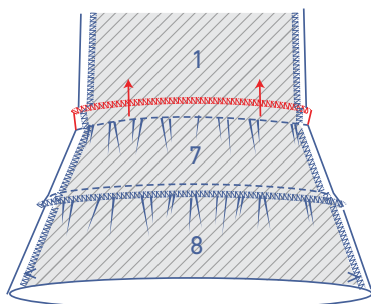
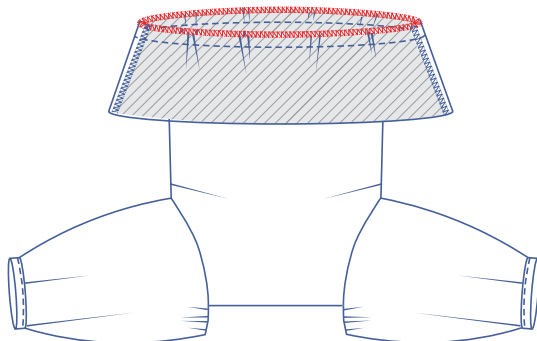

8 Optional

Press the seam allowance from sewing skirt piece A out towards the bodice.

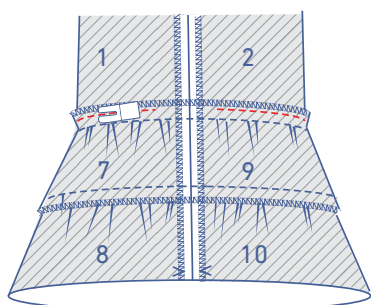

Sew the seam allowance into place at presser foot width from the seam to create a casing. Leave an opening in the side seam to thread through the elastic.

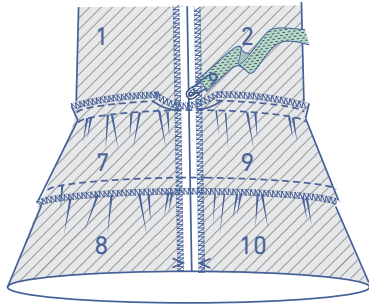

Thread the elastic through the casing via the opening.

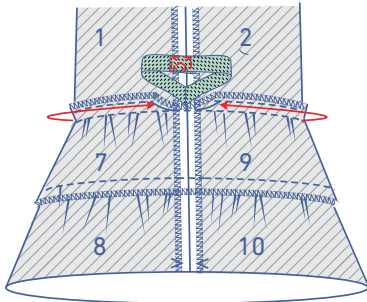

Overlap 3 cm of the ends and sew into place with a Box X stitch.

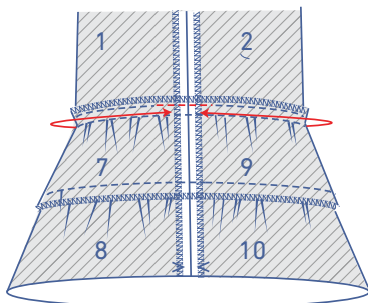
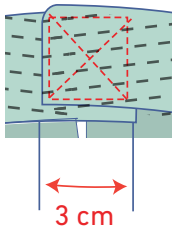

Tuck the elastic neatly back into the casing and sew the opening closed.

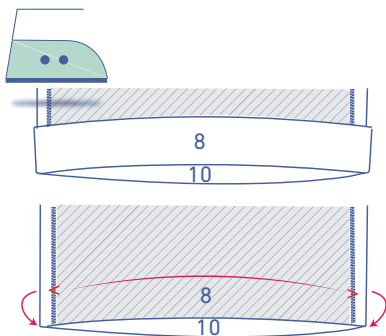

9

Turn the skirt B hem allowance up towards the wrong side, press, and open back out.

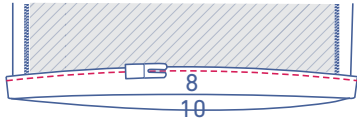
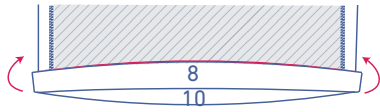
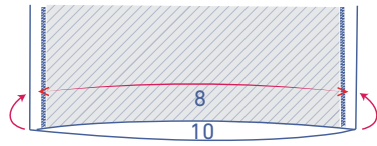

Match the raw edge to meet the pressed fold line and turn up again at the pressed fold line.

Edgestitch into place.

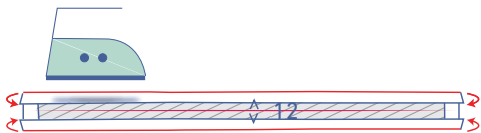
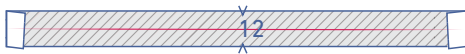
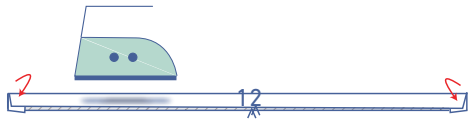
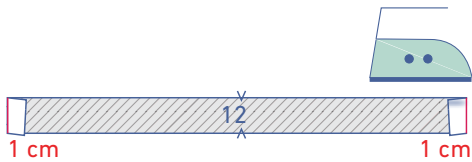

10

Press both short ends of the tie (12) 1 cm towards the wrong side.

Press in half with the long ends together and the wrong sides of the fabric facing each other.

Open back out.

Press the raw edges in to meet the fold line in the middle.

Now, fold back in half along the pressed centre line.

Sew all the way around, right next to the edge.

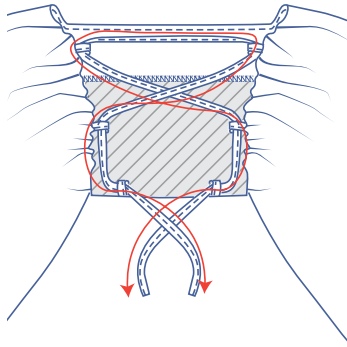

Follow the illustration to thread the tie through the loops.

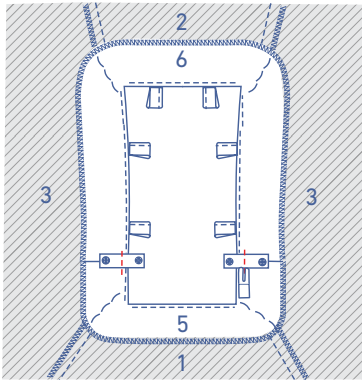

11

Hand sew or stitch the shoulder strap retainers to the facing at the shoulder seams.