

# Danna by Fibre ⚡ood



# Danna by Fibre ood



0 - 26

Danna makes you long for summer. But the great thing is that you don't have to! If it's still chilly out, just throw on a cardigan or jumper. This romantic button-down dress with a lovely square neckline can also be shortened into a comfy top. And... long live ruffles! You'll find them at the top and bottom of the bracelet sleeves and at the front and back; ruffles add an extra degree of comfort while retaining a lot of charm. Wear Danna tightened at the waist with a belt or loose and easy.

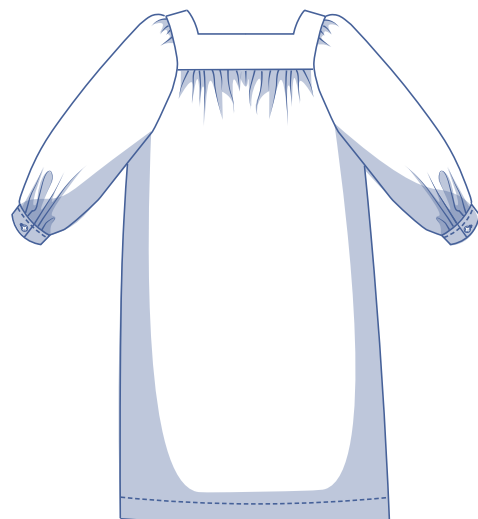
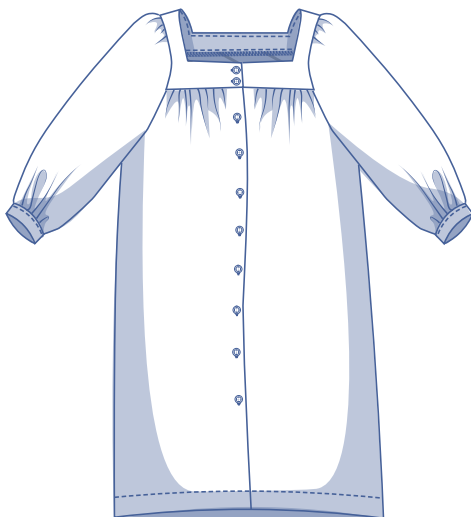
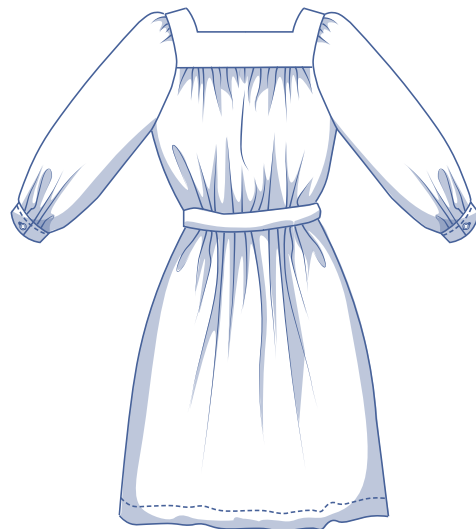
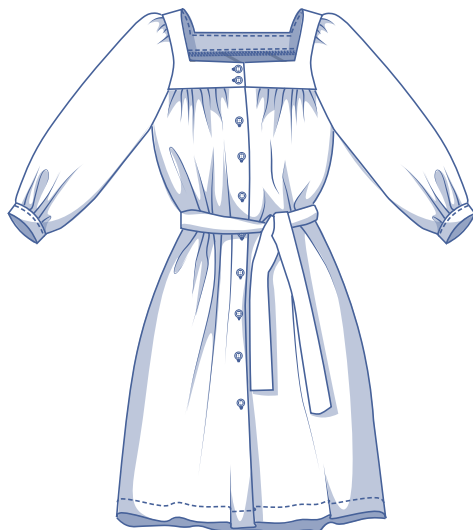

## size chart (in inches)

size	EUR	32	34	36	38	40	42	44	46	48	50	52	54	56	58
	US	0	2	4	6	8	10	12	14	16	18	20	22	24	26
H (height)		5'24"	5'38"	5'45"	5'48"	5'51"	5'54"	5'58"	5'61"	5'64"	5'64"	5'64"	5'64"	5'64"	5'64"
B (bust)		29.9	31.5	33.1	34.6	36.2	37.8	39.4	40.9	43.3	45.7	48	50.4	52.8	55.1
H (hips)		33.9	35.4	37	38.2	39.4	40.6	41.7	42.9	45.3	47.2	49.2	51.2	53.1	55.1

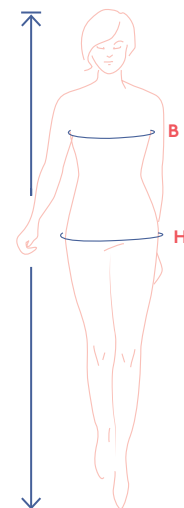

Choose your size based on your **bust measurement**. If your hip measurements are wider than those in the size chart, check the hip measurements in the chart below to see if there's enough room or whether the pattern needs to be altered. It's easy to do. Simply trace the line of the one size instead of the other.

## pattern measurements (in inches)

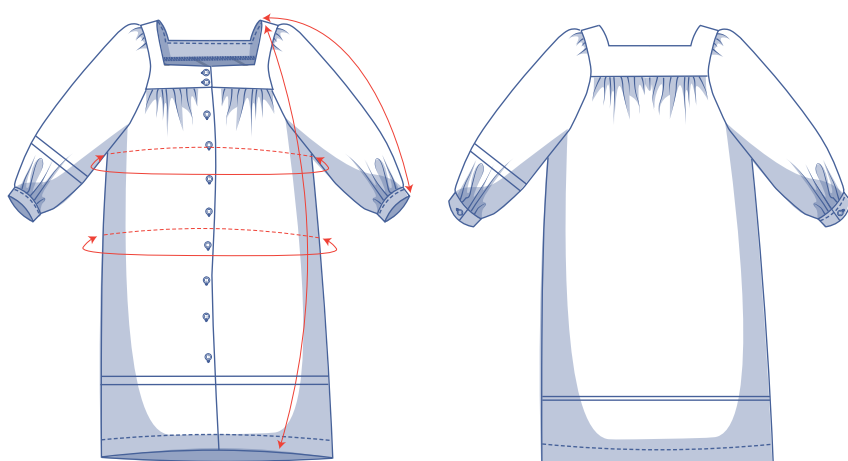

— shorten or lengthen the pattern here

This chart's measurements are the pattern measurements based on the fabric type and serve as a reference. Ease has been added to the width measurements (in addition to the exact body measurements) for a more comfortable fit. Danna is designed to have a more **relaxed cut**. Depending on the preferred cut, you could decide to go a size smaller or larger than the recommended size.

size	0	2	4	6	8	10	12	14	16	18	20	22	24	26
length	40.6	40.8	41	41.2	41.4	41.6	42.6	42.8	44.4	44.7	44.9	45.2	45.4	45.7
sleeve length*	24.7	24.7	24.8	24.8	24.8	24.9	24.9	24.9	25.0	25.1	25.1	25	25	25.3
bust	44.4	46.5	48.6	50.6	52.7	54.7	56.8	58.9	62	65	68.1	71.1	74.2	77.2
hips	46.2	48.3	50.3	52.4	54.4	56.5	58.6	60.6	63.8	66.8	69.9	72.9	75.9	79

\* Including shoulder length and cuff.

Compare the stated lengths to the measured or desired lengths. **Lengthen** or **shorten** the dress and/or sleeves by cutting the pattern pieces at the indicated double lines. Then either increase the distance between the cut pieces by the desired amount (to lengthen), or overlap the pieces (to shorten). Make sure that the CF and CB lines and the side seams are always straight.



### IMPORTANT

Adjust the amount of fabric to be used based on these alterations.

## notions



- Thread
- Iron-on interfacing: max. 1 ⅛ yd
- Buttons (Ø ⅜"): 12
- Fabric: see table

fabric		0	2	4	6	8	10	12	14	16	18	20	22	24	26
fabric width 43"	yd	3 ¼	3 ¼	3 ¼	3 ¼	3 ¼	3 ½	3 ½	3 ½	3 ¾	4 ¼	4 ½	5	5 ½	5 ½
fabric width 55"	yd	2 ½	2 ¾	2 ¾	2 ¾	2 ¾	2 ¾	3	3	3 ¼	3 ½	3 ½	3 ½	3 ½	3 ½

The corresponding fabric layout can be found on page 6 of these sewing instructions.

## fabric advice



Danna looks gorgeous in all kinds of fabrics. Chambray, poplin, Tencel, viscose (crêpe), and double gauze are just a few examples. However, due to the delicate neckline stitching, wovens work better than knit fabrics.

# Proud to be #Sewista

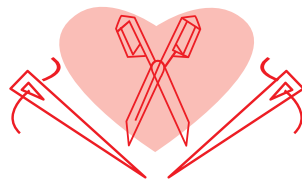

## pattern pieces & seam allowances (in inches)

To sew the garment as described in the instructions, draw the illustrated seam allowances around the paper pattern pieces before cutting them out. If you are using a PDF pattern, the pattern can be printed with or without seam allowance.

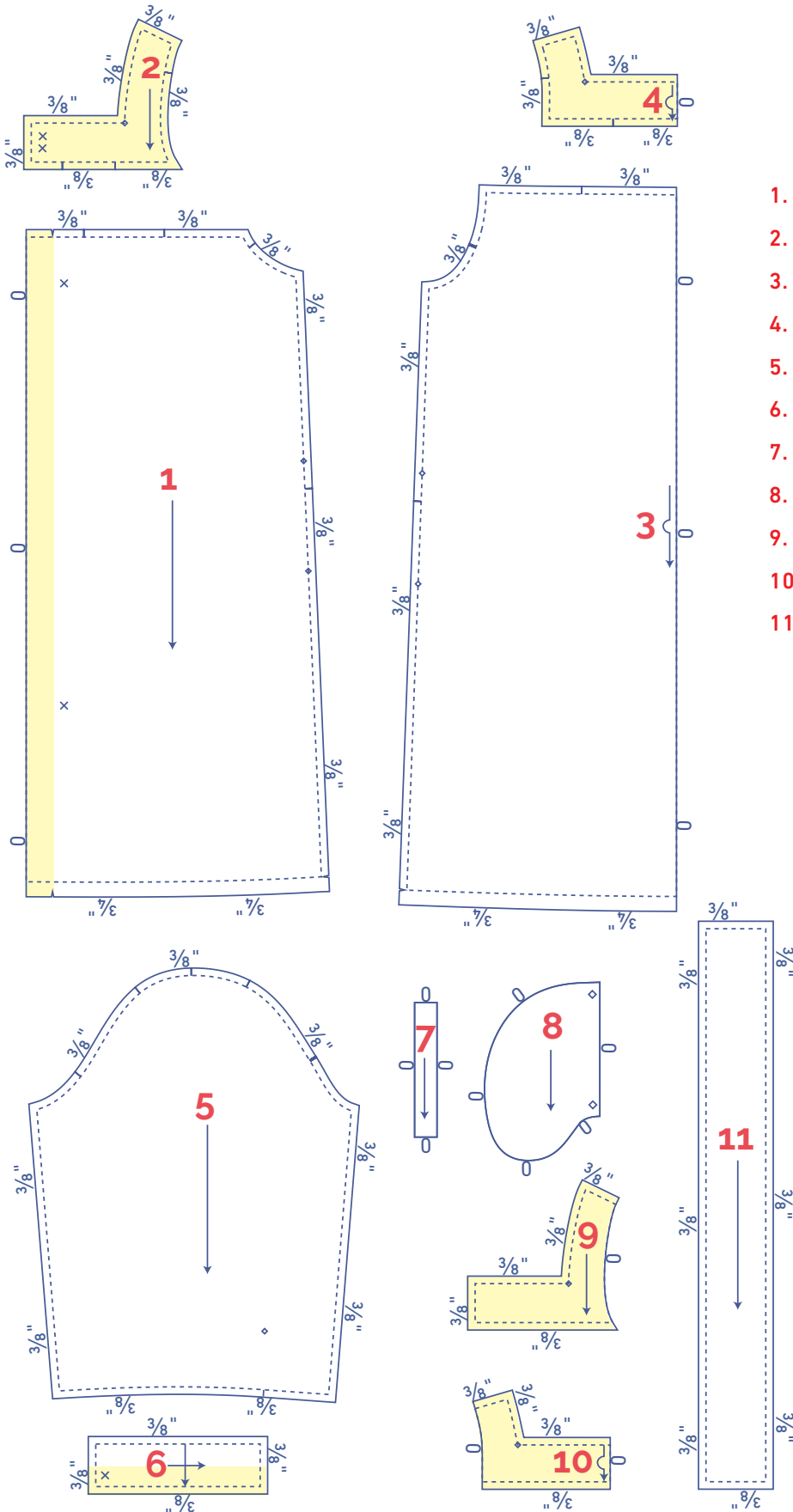

To find out more, watch the [video](#).



1. front: 2x
2. top piece front: 2x
3. back: 1x on fabric fold
4. top piece back: 1x on fabric fold
5. sleeve: 2x
6. cuff: 2x
7. sleeve binding: 2x
8. pocket: 4x
9. facing front top: 2x
10. facing back top: 1x on fabric fold
11. belt: 2x

### IMPORTANT

The pieces highlighted in light yellow have iron-on interfacing attached to the wrong side.

	material type
	fabric
	iron-on interfacing

**fabric layout – solid fabrics**  
**fabric width 43"**

0 - 8

10 - 16

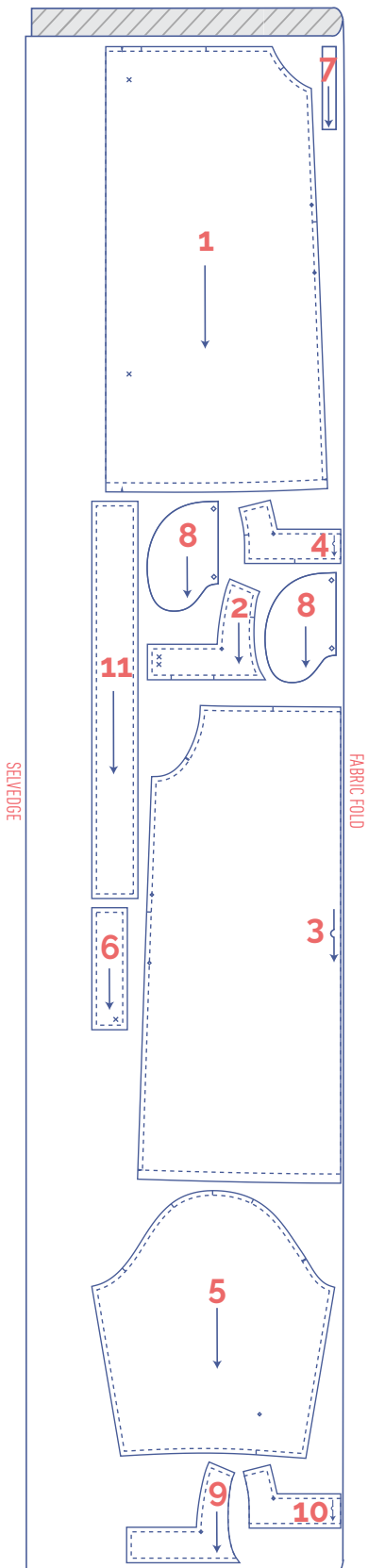
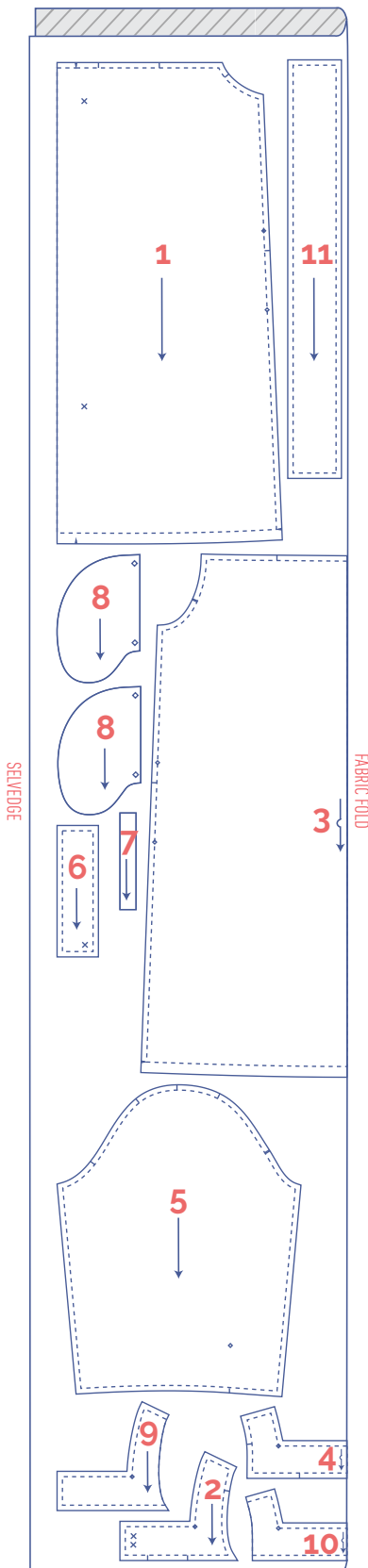

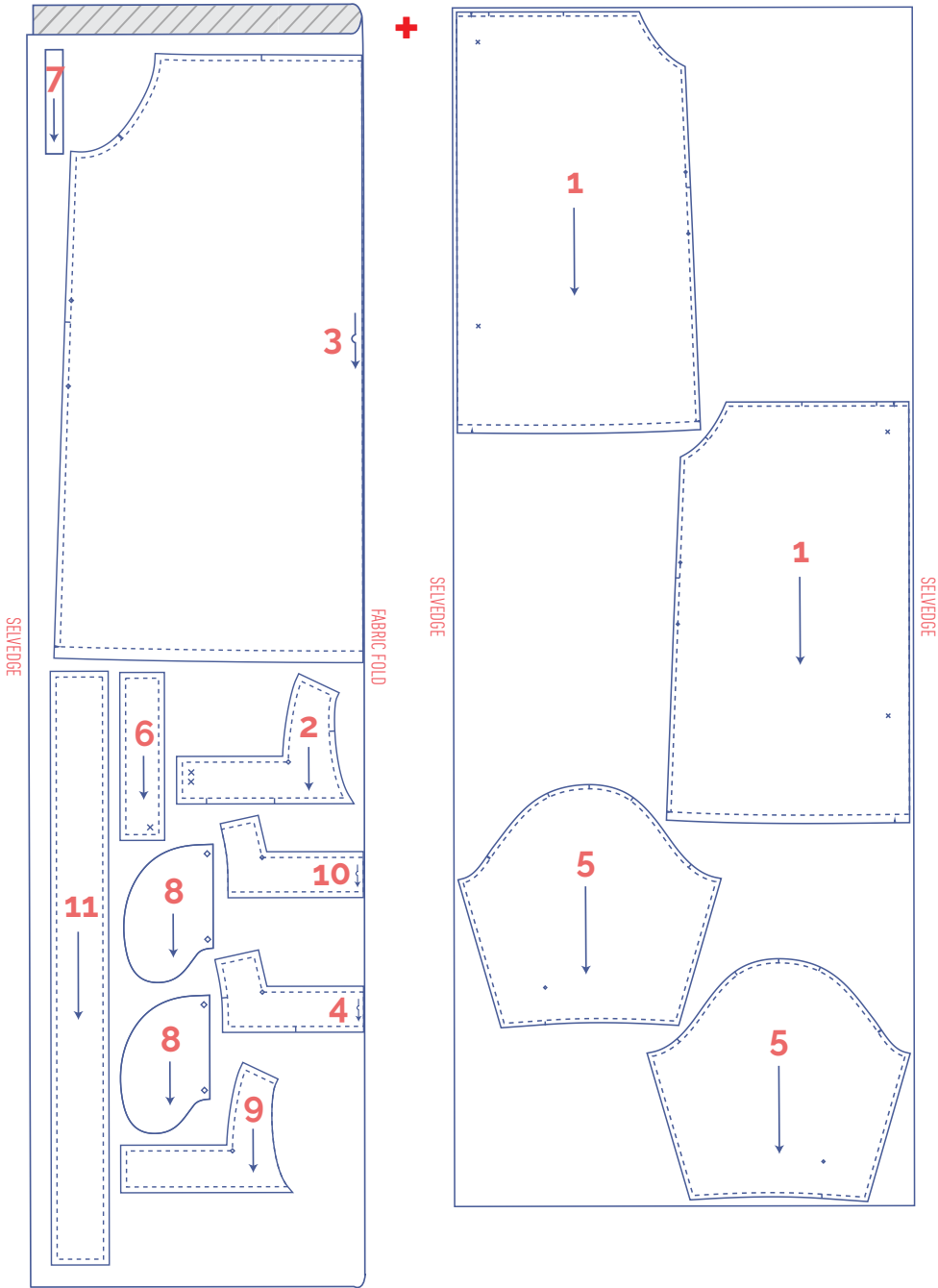

**fabric layout – solid fabrics**  
**fabric width 55"**

0 - 4

6 - 16

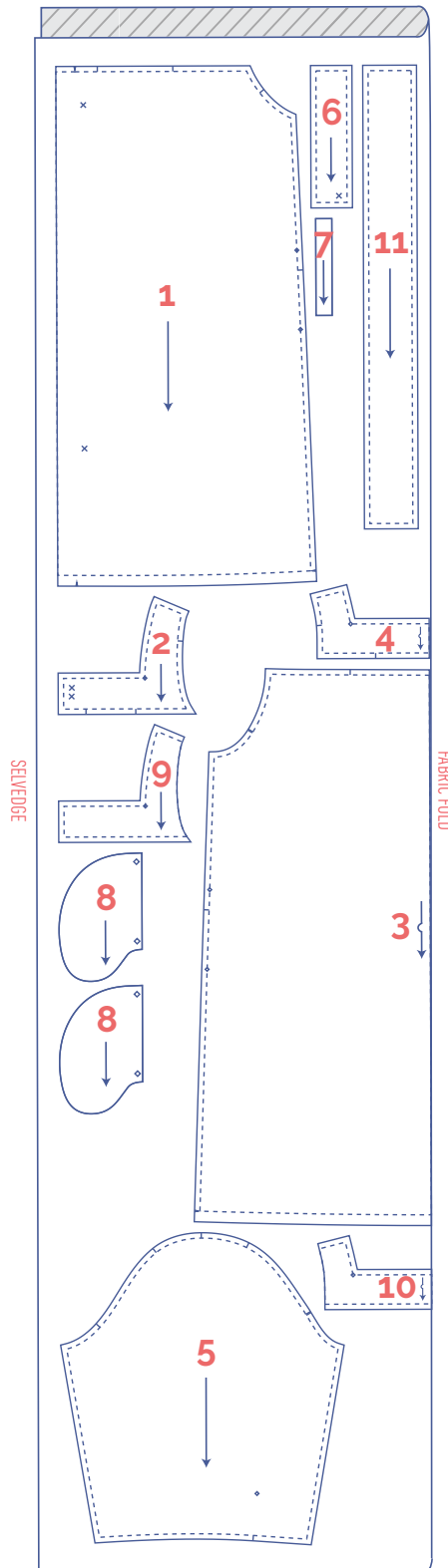
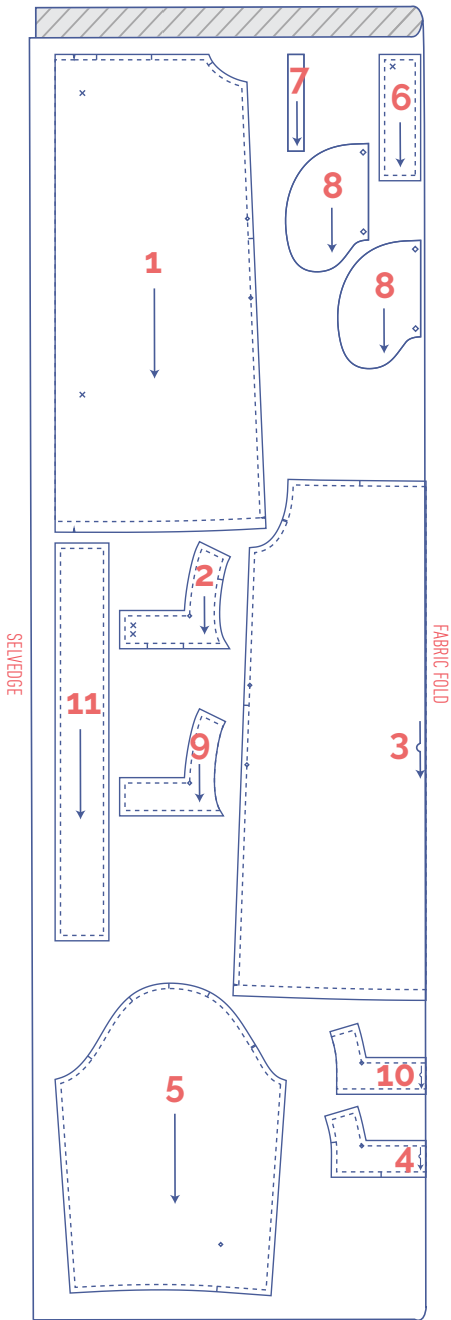



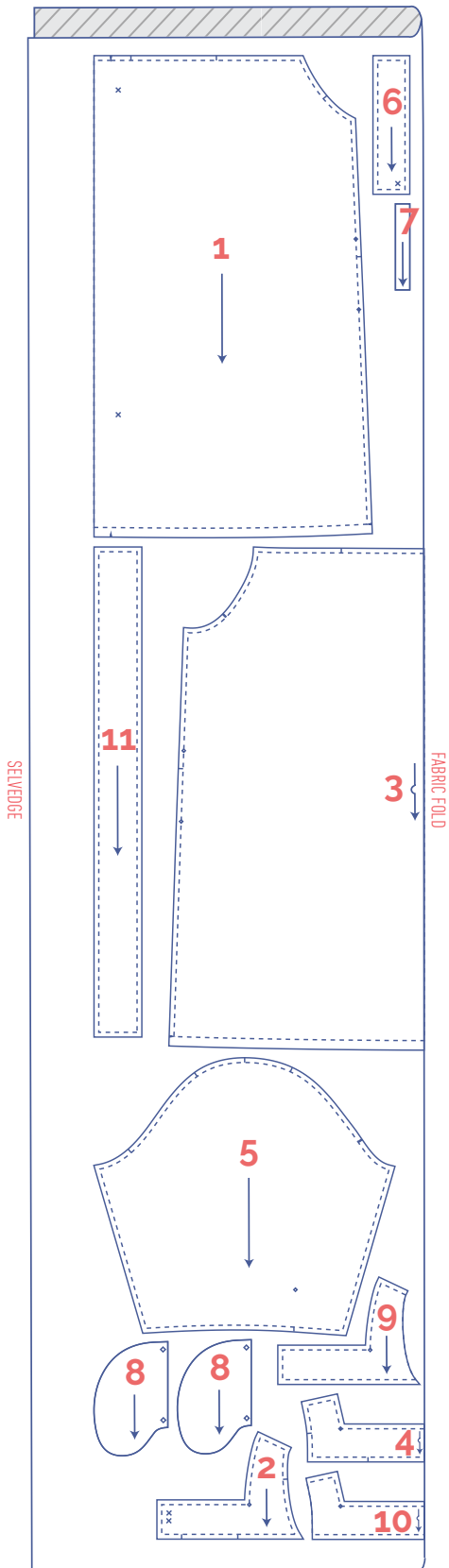

## marking pattern pieces



Notch the pattern paper and fabric at the following points



single notch



double notch



V notch



Mark the following points using marking thread



centre point



buttons

# sewing instructions



The method used to finish the seams depends on the fabric used.  
The pieces are always sewn together with the right sides of the fabric facing, unless stated otherwise.

F front

B back

RF right front

LF left front

CF centre front

CB centre back

 right side

 wrong side

 iron-on interfacing

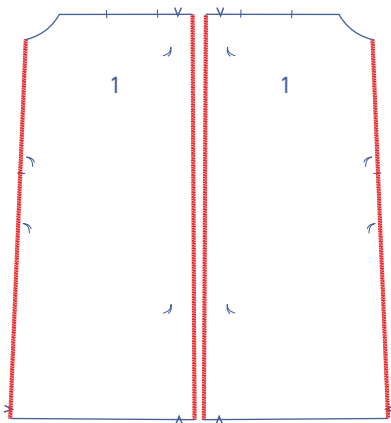

**1**

Finish the indicated edges of the front (1) with overlock stitching.

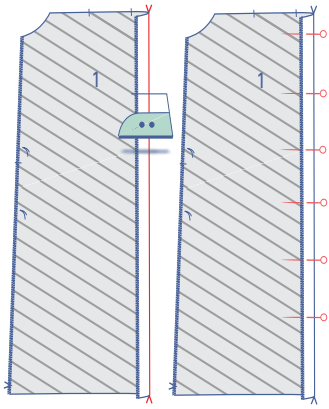

Press the facing over towards the wrong side at the V notches. Pin temporarily into place.

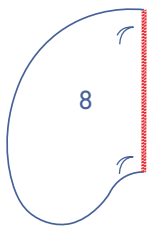

Finish the straight edges of the pocket pieces (8) with overlock stitching.

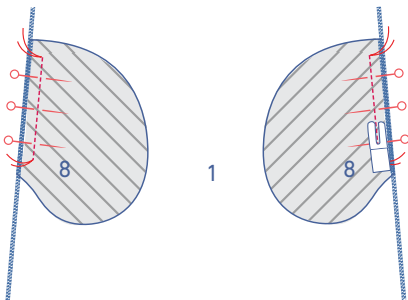

Pin the straight end of 2 of the 4 pocket pieces to the front, matching the marking threads. Sew into place between the marking threads.

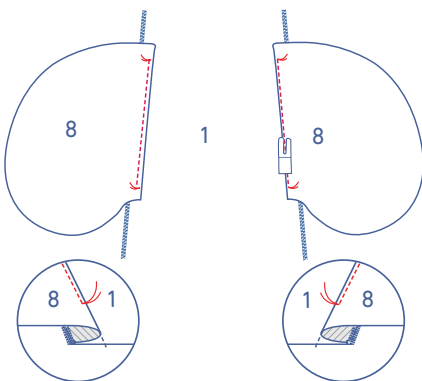

Fold the pocket and seam allowance over and sew the pocket to the seam allowance underneath.

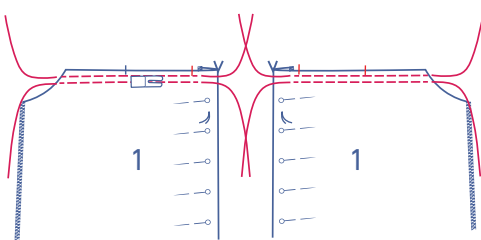

Starting just past the indicated notch, sew 2 parallel rows of stitching at the top of the front using a long stitch length at a low thread tension. Take care not to catch the facing (the folded part)

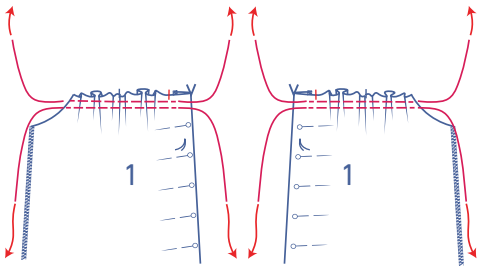

Carefully tug the ends of the threads to gather the fabric into ruffles.

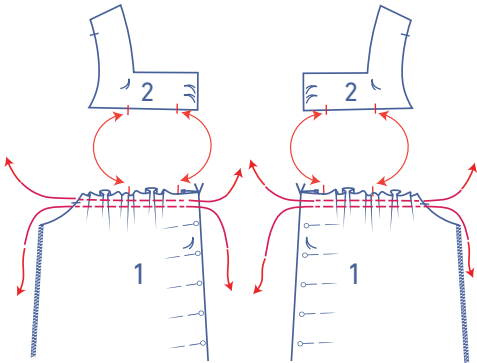

Distribute the ruffles so that the notches in the front match the notches in the top front (2).

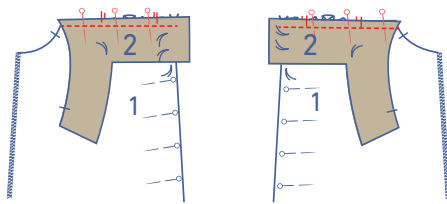

Pin and sew the front to the top front with the corresponding notches matching. There will be  $\frac{3}{8}$ " of seam allowance of the front top extending past the front.

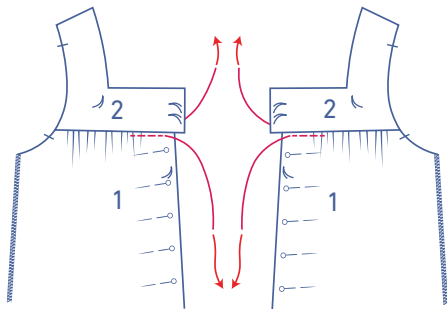

Remove the gathering threads.

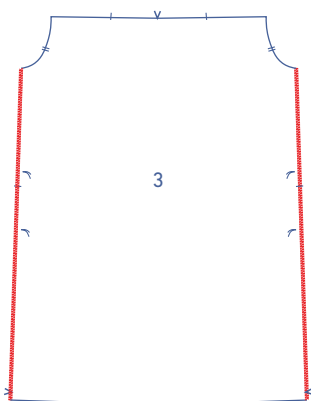

## 2

Finish the side seams of the back (3) with overlock stitching.

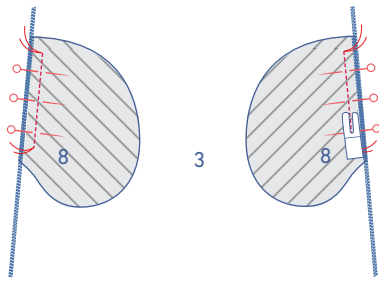

Pin the straight ends of the 2 remaining pocket pieces to the back, matching the marking threads. Sew into place between the marking threads.

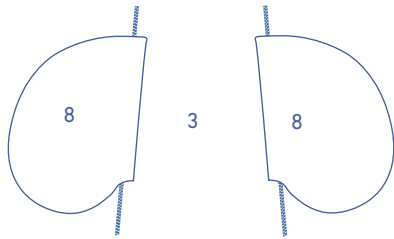

Fold the pocket pieces to the side.

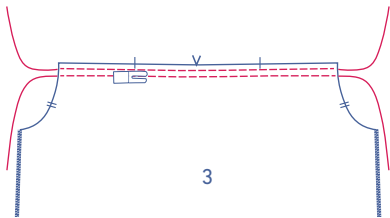

Sew 2 parallel rows of stitching at the top of the back, using a long stitch length and a low thread tension. Leave long thread tails at the start and the end.

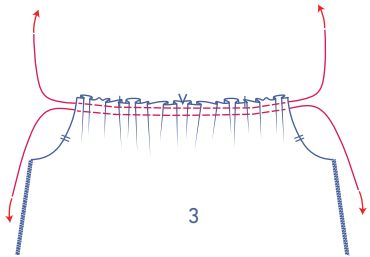

Carefully tug the ends of the threads to gather the fabric into ruffles.

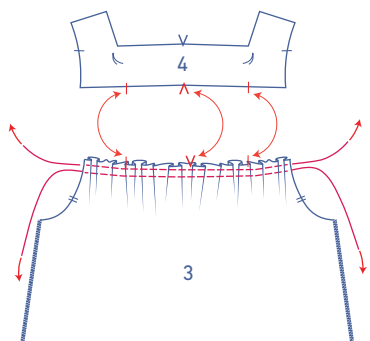

Distribute the ruffles so that the notches in the back match the notches in the top back (4).

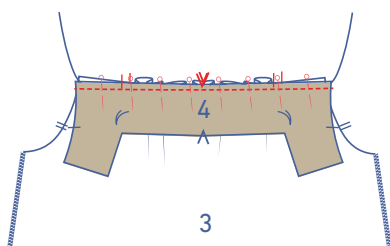

Pin and sew the back to the top back with the corresponding notches matching.

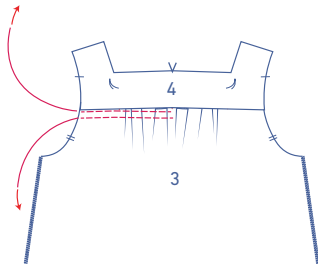

Remove the gathering threads.

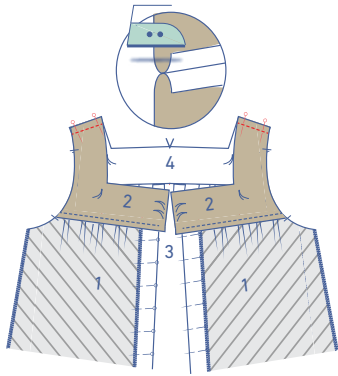

### 3

Pin and stitch the shoulder seams. Press the seam allowances open.

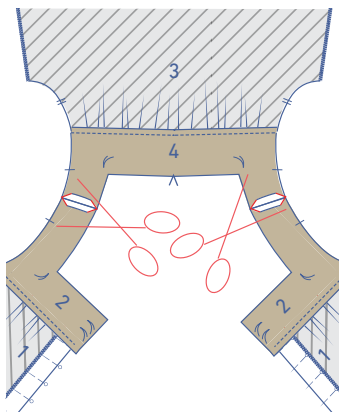

Trim the seam allowance at the tips at an angle to prevent the fabric from bunching.

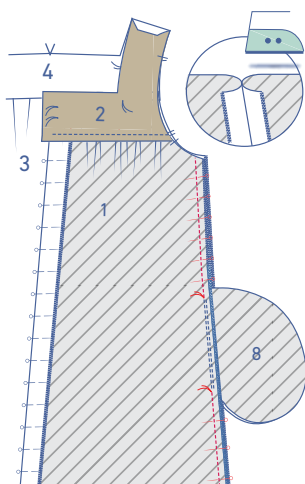

### 4

Pin and sew the side seams together. Sew from the armhole down to the marking thread indicating the top of the pocket opening. Now, stitch from the next marking thread down to the hem. Press the seam allowance open.

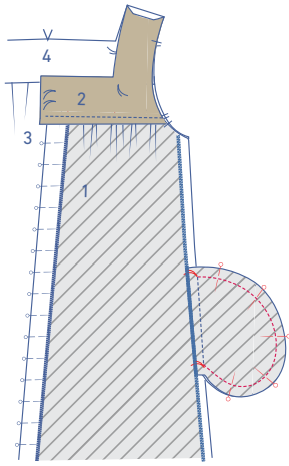

Pin and sew the edges of the pocket pieces together.

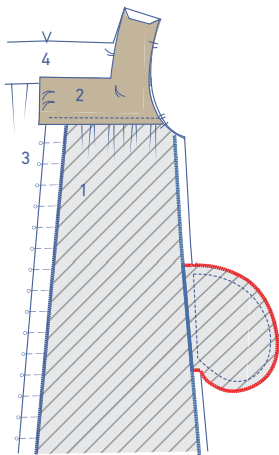

Finish the raw edges with overlock stitching.

---

## 5

Finish the sides of the sleeve (5) with overlock stitching.

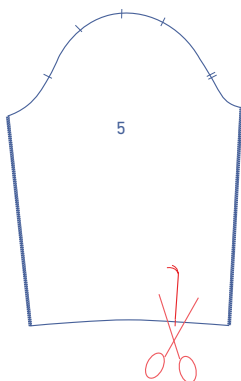
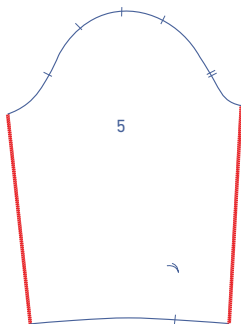

Snip into the sleeve from the notch in the hem up to the marking thread.

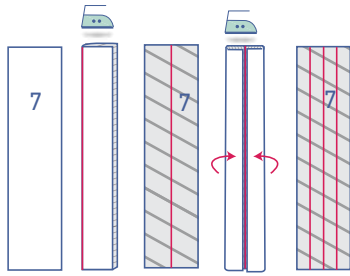

Press the sleeve binding (7) as follows:

- Start by pressing the bias in half lengthwise all the way down to create a fold line.
- Next, press the long ends until the raw edges meet the fold line.
- Open the bias tape back out.

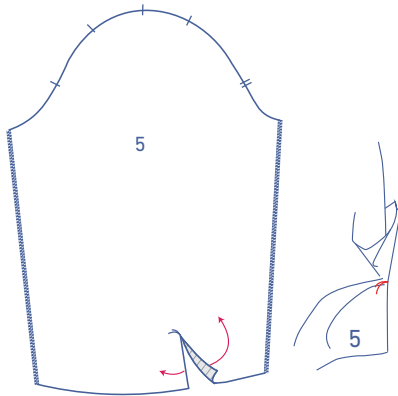

Open the sleeve split so that you end up with a single straight line.

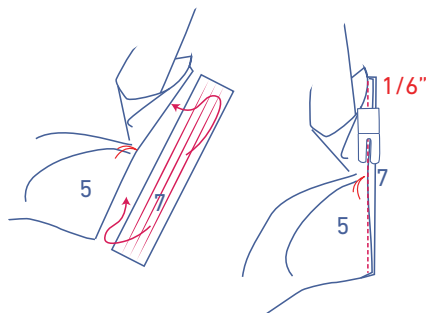

Slide the sleeve binding under the sleeve with the right side facing up. Line up the long ends of the bias tape with the edges of the sleeve split. At the marking thread, pull the sleeve a little to the side. Sew into place at  $\frac{1}{6}$ ". You'll only have sewn a tiny bit of fabric at the marking thread.

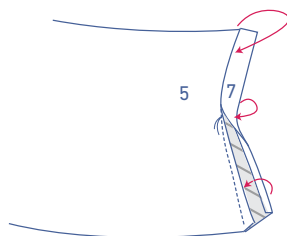

Fold the sleeve binding onto the right side of the sleeve. Tuck the raw edge under and place the pressed fold line directly over the previous stitching. Sew into place right next to the edge.

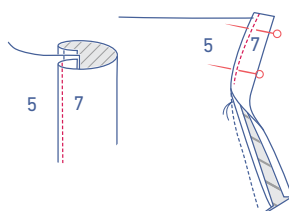

Edge stitch into place.



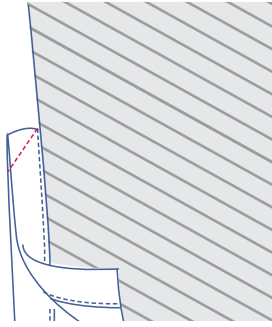

Fold the sleeve in half crosswise with the right sides facing. Sew the top of the sleeve binding together at an angle.

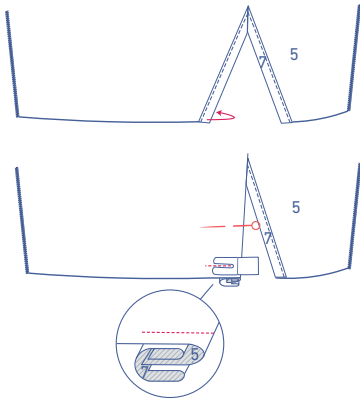

Fold the sleeve binding at the front of the sleeve (i.e., the widest side) over to the wrong side of the sleeve.

Sew the sleeve binding into place at presser foot width from the bottom.

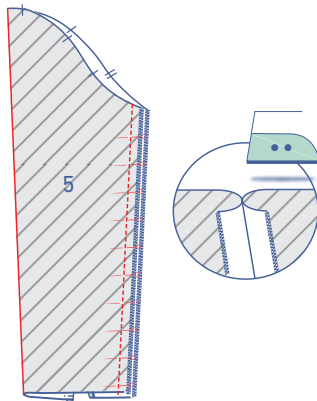

Pin and sew the sleeve sides. Press the seam allowances open.

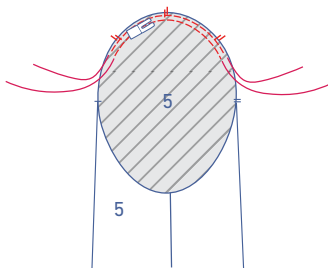

Sew two parallel rows of stitching from the top of the sleeve, using a long stitch length at a low thread tension. Sew just past the indicated single notches. Leave a length of thread at the start and end of the rows.

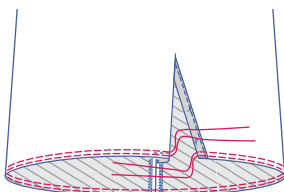

Stitch two parallel rows along the bottom of the sleeve, using a long stitch at a low thread tension. Leave a length of thread at the start and end of the rows.

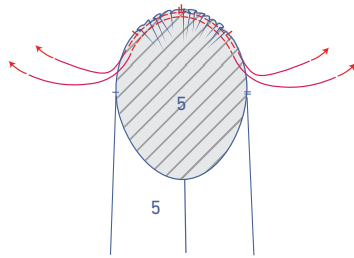

Carefully tug the ends of the threads to gather the fabric into ruffles.

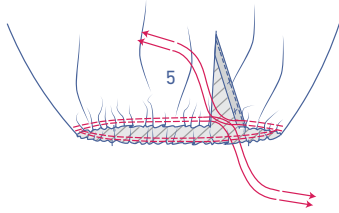

Fold the cuff (6) in half lengthwise with the wrong sides of the fabric facing each other to create a fold line. Open back up.

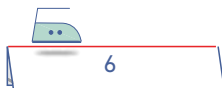

Press the long side of the edge with the marking thread 3/8" over to the wrong side.

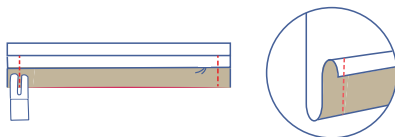
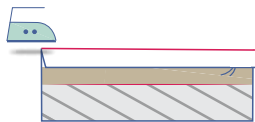

Fold the cuff in half at the pressed fold line with the right side of the fabric facing inwards. Sew the short ends.



Turn the cuff the right way out.

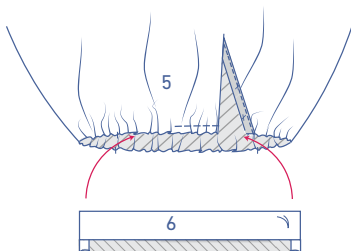

Pin the unpressed raw edge of the cuff to the bottom of the sleeve along the inside (= the wrong side). Distribute the ruffles so that the bottom of the sleeve matches the cuff.

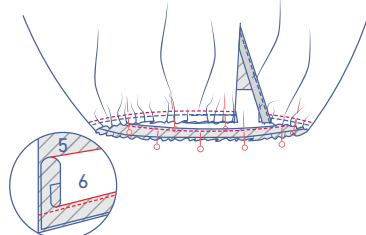

Stitch into place.

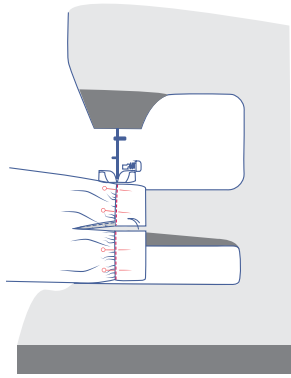

Turn the cuff over to the right side of the sleeve. Place the fold line directly over the stitching. Edge stitch into place.

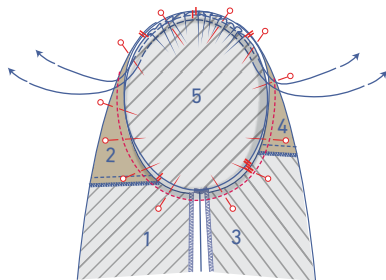

## 6

Pin and sew the top of the sleeve (= sleeve cap) to the armhole with the notches matching. The single notch marks the front, while the double notch marks the back. The single notch at the top aligns with the shoulder seam. Distribute the ruffles so that the top single notches in the sleeve match the notches in the top.

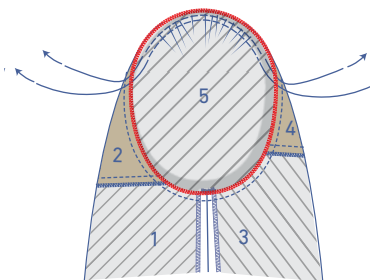

Finish the raw edges with overlock stitching.

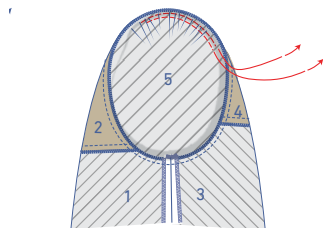

Remove the gathering threads.

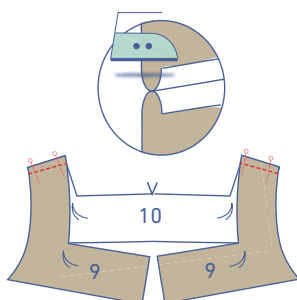

## 7

Pin and sew the shoulder seams of the facing front top (9) and facing back top (10). Press the seam allowances open.

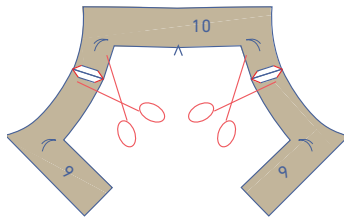

Trim the seam allowance at the tips at an angle to prevent the fabric from bunching.

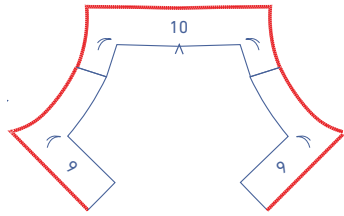

Finish the indicated edges of the facing with overlock stitching.

3

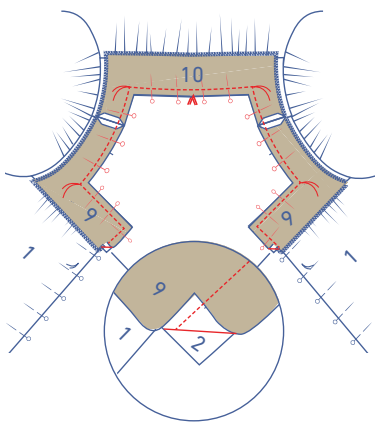

Place the facing on top of the dress, right sides together. Pin and sew the neckline where indicated.

Each time you reach a corner (marked with a marking thread), leave the needle in the fabric, raise the presser foot, turn the garment, lower the presser foot back down and continue sewing.

3

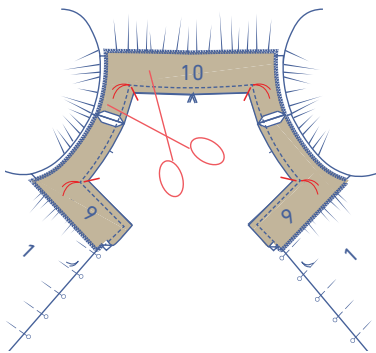

Snip diagonally towards the corners in the seam allowance. **Note:** to make clean right angles, snip until just before the marking thread!

3

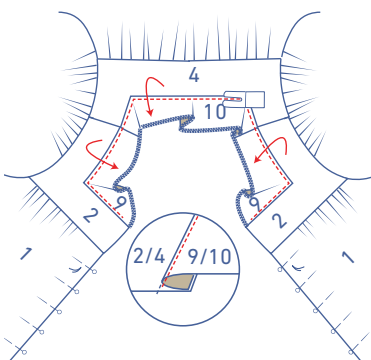

Fold the facing and seam allowance over and sew the facing to the seam allowance underneath, right next to the seam. This will give your neckline nice, clean lines. Make sure that any time you fold or move fabric out of the way, that the straight edges you will be stitching are as flat as possible.

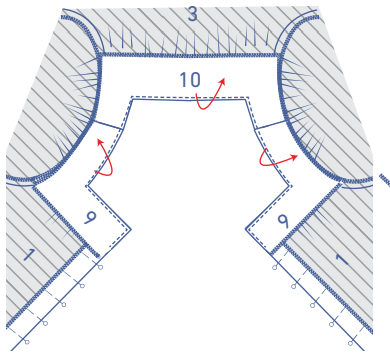

Turn the facing towards the wrong side.

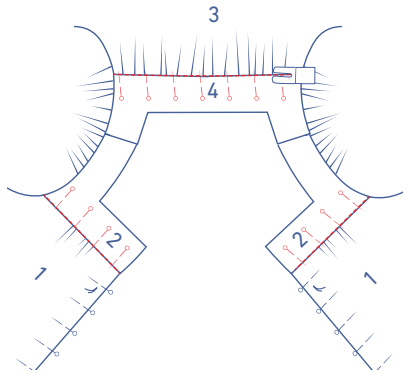

Pin it into place along the right side. Secure by stitching in the ditch from the right side.

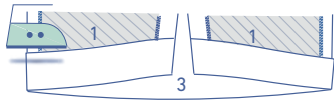

**8**

Turn the hem allowance up over the wrong side, press, and open back out.

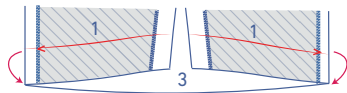

Place the raw edge against the pressed fold line and fold and fold back up along the pressed fold line.

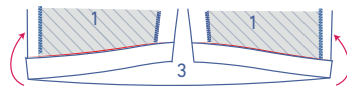
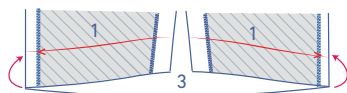

Edge stitch into place.

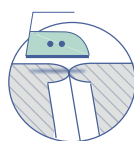
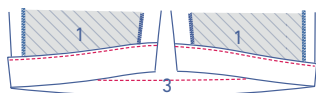

**9**

Sew the short sides the belt pieces (11) together. Press the seam allowance open.



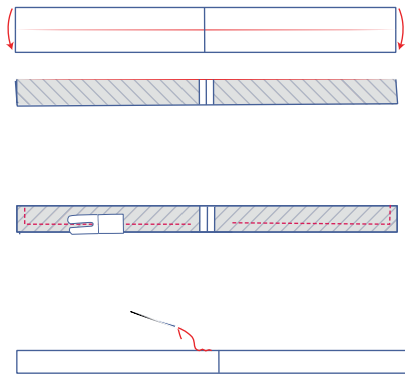

Fold the belt in half lengthwise with the right sides of the fabric facing.

Sew the indicated sides but leave an opening to turn the belt the right way out again.

Turn the belt the right way out and sew the opening closed.

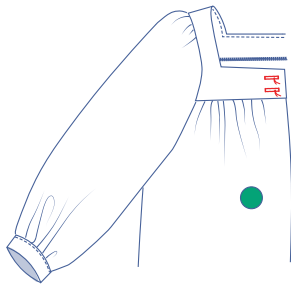

## 10

Make 2 horizontal buttonholes on the top RF based on the location of the buttons.

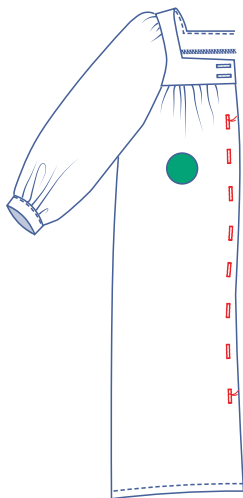

Make vertical buttonholes on the RF at the places marked. The top and bottom button have been marked on the pattern. Divide the distance between these 2 evenly to determine the location of the other buttons.

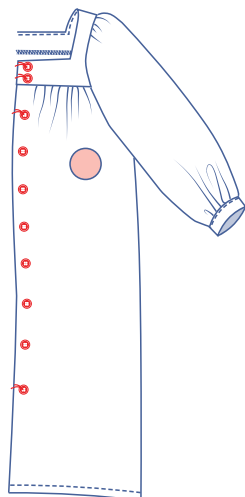

Sew on buttons.

Make a horizontal buttonhole halfway up cuff and  $\frac{3}{8}$ " from the edge.

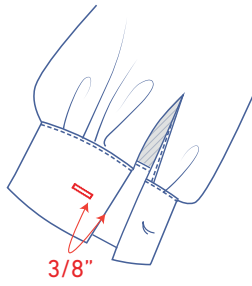

Sew the button on where indicated.

