

Bloom by Fibre ⚡ood



Bloom by Fibre ood



4 - 30

A Bloom for every day of the week – why ever not? Really, you can never get enough of this paperbag skirt. This straight skirt features an elastic waist with adjustable ties so you know it always fits perfectly! Know what there's no need to get tied up in knots about? With Bloom, your dream skirt is ready in 1-2-3. After all, the pattern only consists of two pieces that will take you no time to trace, cut out, and sew together. Ready, set, go!

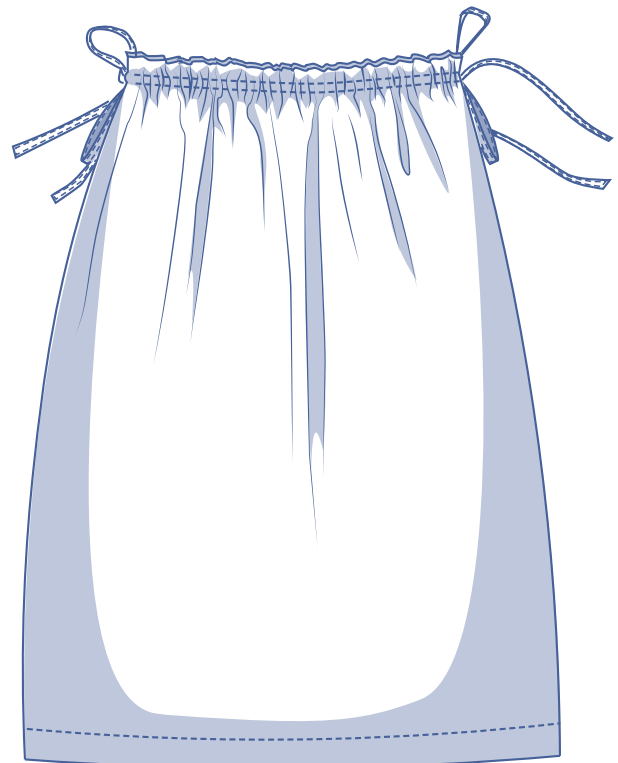
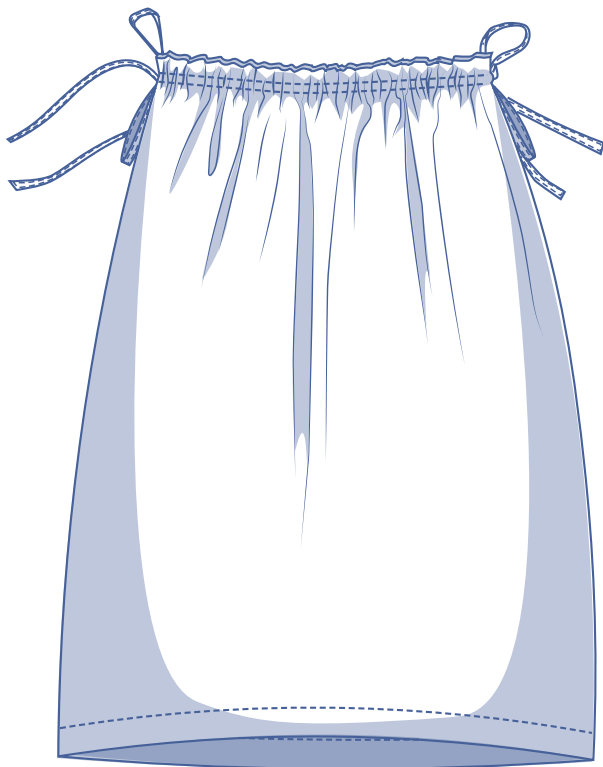

size chart (in cm)

size	EUR	32	34	36	38	40	42	44	46	48	50	52	54	56	58
	UK	4	6	8	10	12	14	16	18	20	22	24	26	28	30
H (height)		160	164	166	167	168	169	170	171	172	172	172	172	172	172
W (waist)		66	68	70	74	78	82	84	88	94.5	101	107.5	114	120.5	127
H (hips)		86	90	94	97	100	103	106	109	115	120	125	130	135	140

Choose your size based on your **hip measurement**. Pick the size that is the best match for the hips. The waistline measurement is a snap to alter with the elastic and the ties.

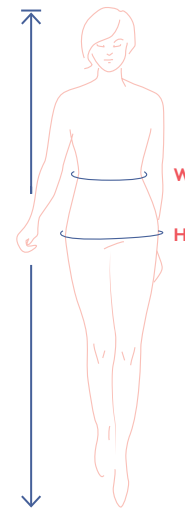

pattern measurements (in cm)

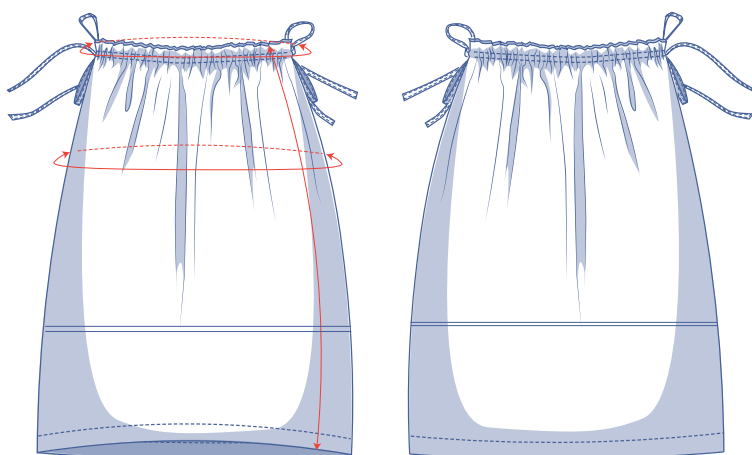

This chart's measurements are the pattern measurements based on the fabric type and serve as a reference. Ease has been added to the width measurements (in addition to the exact body measurements) for a more comfortable fit. Bloom is designed to have a **comfortable** cut.

— shorten or lengthen the pattern here

size	4	6	8	10	12	14	16	18	20	22	24	26	28	30
side length*	74.25	74.5	75	75.25	75.5	75.75	76	76.25	77.75	78	78.25	78.5	78.75	79
waistline without elastic	100.25	102.25	104.25	108.25	112.25	116.25	118.25	122.25	128.25	134.25	140.25	146.25	152.25	158.25
hips	106.25	110.25	114.25	117.25	120.25	123.25	126.25	129.25	135.25	140.25	145.25	150.25	155.25	160.25

* Keep in mind that this length extends 1.5 cm above the natural waist.

Compare the stated lengths to the measured or desired lengths. **Lengthen** or **shorten** the skirt by cutting the pattern pieces at the indicated double lines. Then either increase the distance between the cut pieces by the desired amount (to lengthen) or overlap the pieces (to shorten). Make sure that the CF and CB lines and the side seams are always straight.



IMPORTANT

Adjust the amount of fabric to be used based on these alterations.

notions

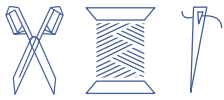

- Thread
- Elastic* (width 0.5 cm): see table
- Fabric: see table

elastic*		4	6	8	10	12	14	16	18	20	22	24	26	28	30
length	cm	60	62	64	68	72	76	78	82	89	95	102	108	115	121

* The measurements of the elastic (3 cm overlap included) are only indicative and depend on the type of elastic. To determine the exact length, use the elastic to measure around the waist. Add 3 cm to this.

fabric		4	6	8	10	12	14	16	18	20	22	24	26	28	30
fabric width 110 cm	cm	170	170	170	170	170	170	170	170	175	175	175	175	175	180
fabric width 140 cm	cm	110	110	110	115	115	170	170	170	175	175	175	175	175	180

The corresponding fabric layout can be found on page 6 of these sewing instructions.

fabric advice



The Bloom skirt pattern is so simple that just about any fabric will work. Structured fabrics (e.g. poplin and linen) and fabrics with a fluid drape (e.g. viscose, viscose crêpe, satin, Tencel, etc.) are equally good options. But you don't have to limit yourself to wovens, of course. Knit fabrics (e.g. French terry bamboo blends, light jacquards, etc.) could also yield a stunning result. Prints? Well, just let your imagination run wild! The design itself is simple, so why not steal the show with a statement print? Bloom in plissé sounds like a winner to us! Think maximum wow for minimal effort.

Proud to be #Sewista

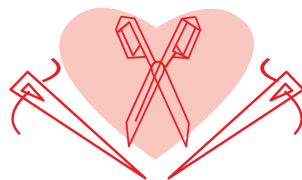

pattern pieces & seam allowances (in cm)

To sew the garment as described in the instructions, draw the illustrated seam allowances around the paper pattern pieces before cutting them out. If you are using a PDF pattern, the pattern can be printed with or without seam allowance.

To find out more, watch the [video](#).

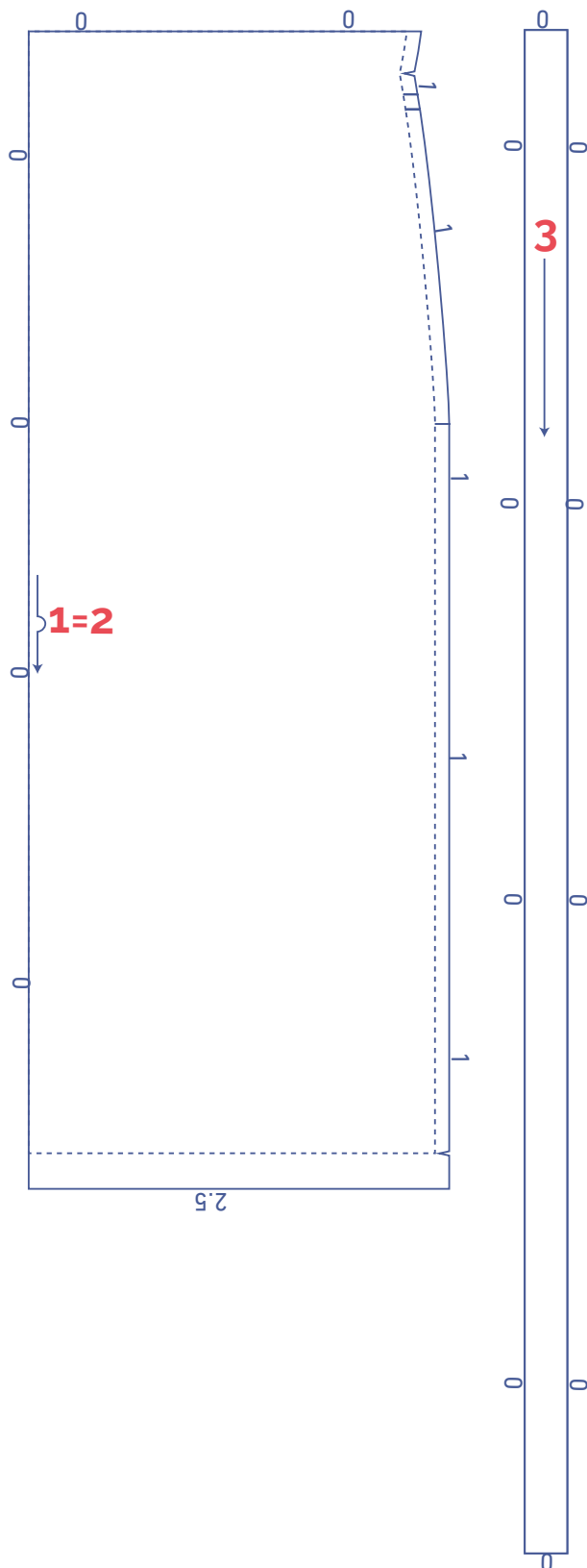

1. front: 1x on fabric fold
2. back: 1x on fabric fold
3. tie: 2x

IMPORTANT

Pattern pieces 1 and 2 are the same.

fabric layout – solid fabrics fabric width 110 cm

4 - 30

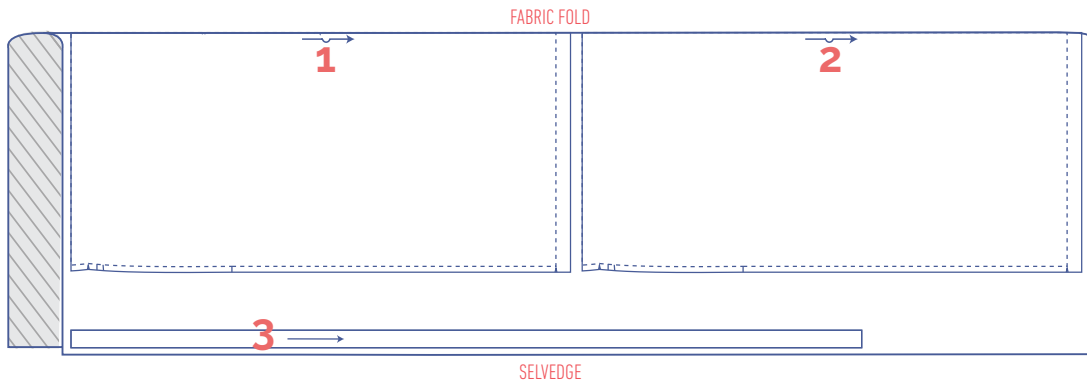

fabric layout – solid fabrics fabric width 140 cm

4 - 12

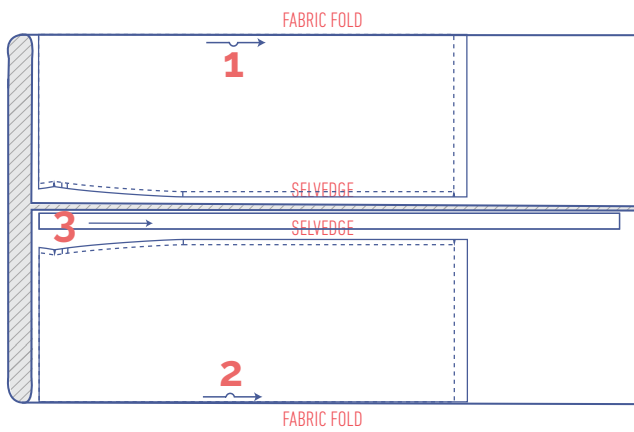

14 - 30

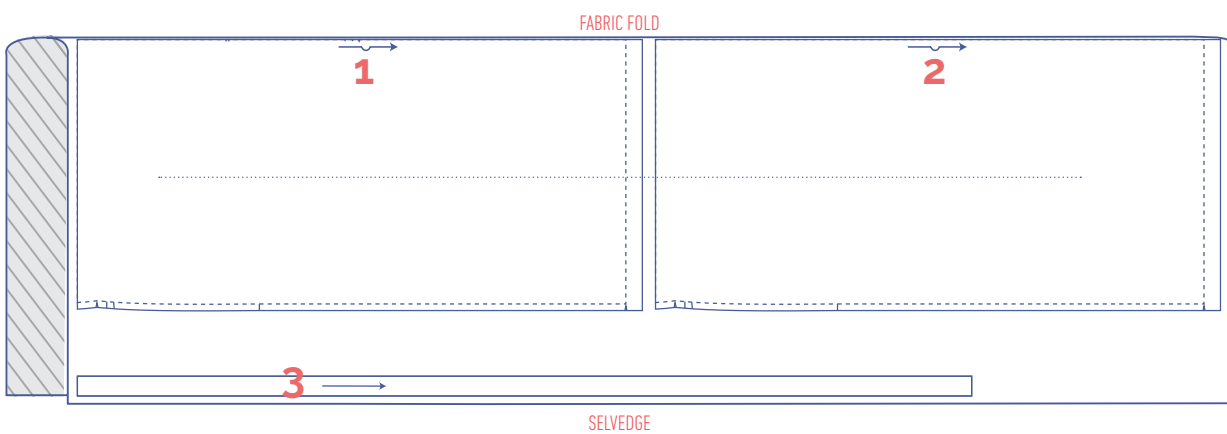

marking pattern pieces



Notch the pattern paper and fabric at the following points

| single notch

|| double notch

V V notch

sewing instructions



The method used to finish the seams depends on the fabric used.
The pieces are always sewn together with the right sides of the fabric facing, unless stated otherwise.

F front

B back



right side



wrong side



elastic

1

Finish the side seams of the front (1) and back (2) with overlock stitching.

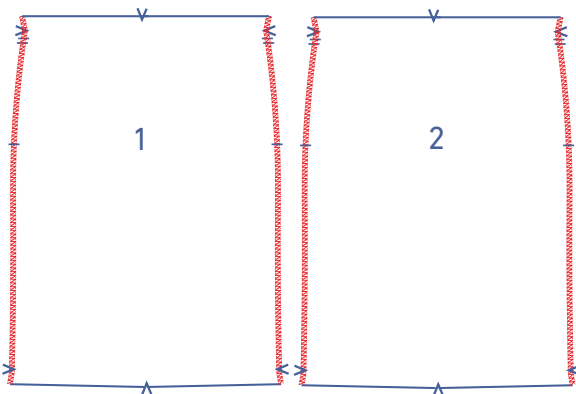

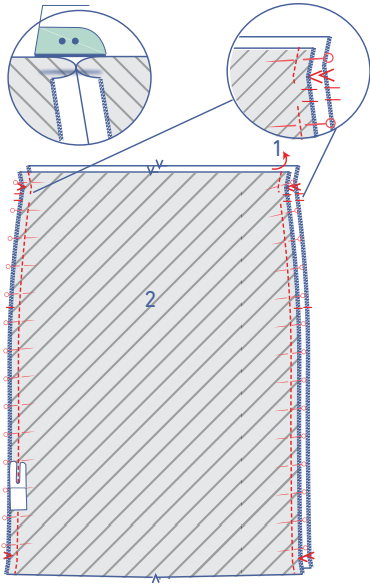

Pin and sew the side seams together. Leave an opening between the single notches so that you can thread the elastic and the tie through later. Press the seam allowance open.



Finish the top and bottom of the skirt with overlock stitching.



Press the facing over towards the wrong side at the V notches.

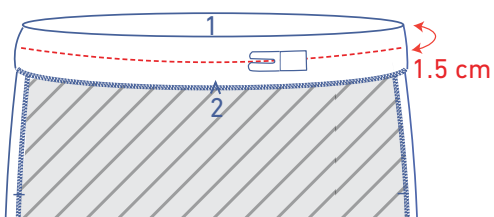
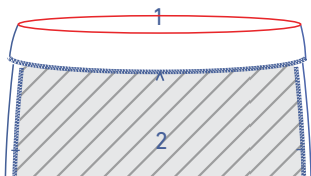

To make the casing, first stitch a line of topstitching at 1.5 cm from the top edge.

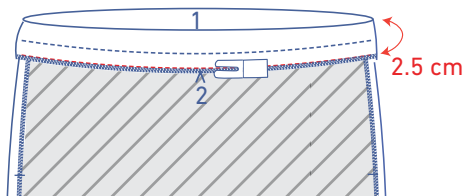

Stitch a second line of topstitching at 2.5 cm away from edge. That will be the 1-cm-wide casing's bottom row of stitching.

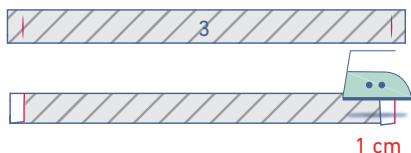

2

Press each short end of the ties (3) 1 cm over towards the wrong side.

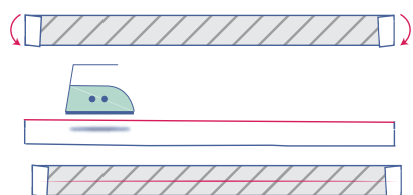

Press in half lengthwise with the wrong sides of the fabric facing.

Open back out.



Press the long ends in to meet the pressed centre line.



Press in half.



Stitch into place all the way around, right next to the edge.

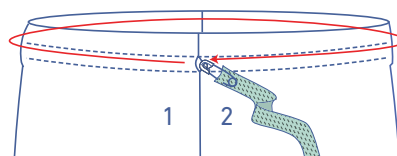

Thread the elastic through the casing through the opening in the side seam.

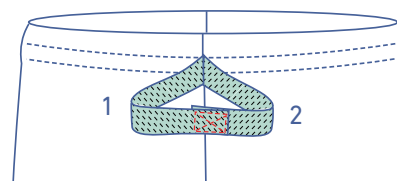

Overlap 3 cm of the ends and sew into place with a Box X stitch. Pull the elastic all the way through the casing.

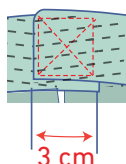

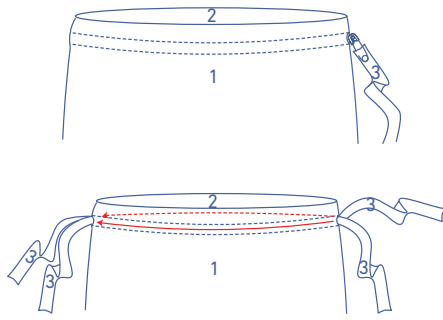

Thread 1 tie via the opening in the side seam through the casing at the front to the opening in the other side seam. Thread the other tie via the opening in the side seam through the casing at the back to the opening in the other side seam.

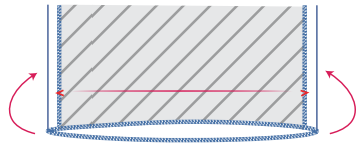

3

Press the hem allowance up towards the wrong side.

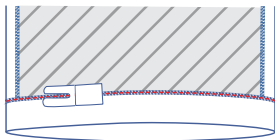

Stitch into place.