

Alena by Fibre ood



Alena by Fibre



4 - 32

At first glance, Alena looks like a simple, casual dress with a round neckline and short sleeves. Spin her 'round though and you'll discover an elegantly designed back opening. At the back, the elastic brings in the waist of the dress a striking accent. Alena is designed with a subtle, fitted cut. She will look gorgeous in whatever length you choose.

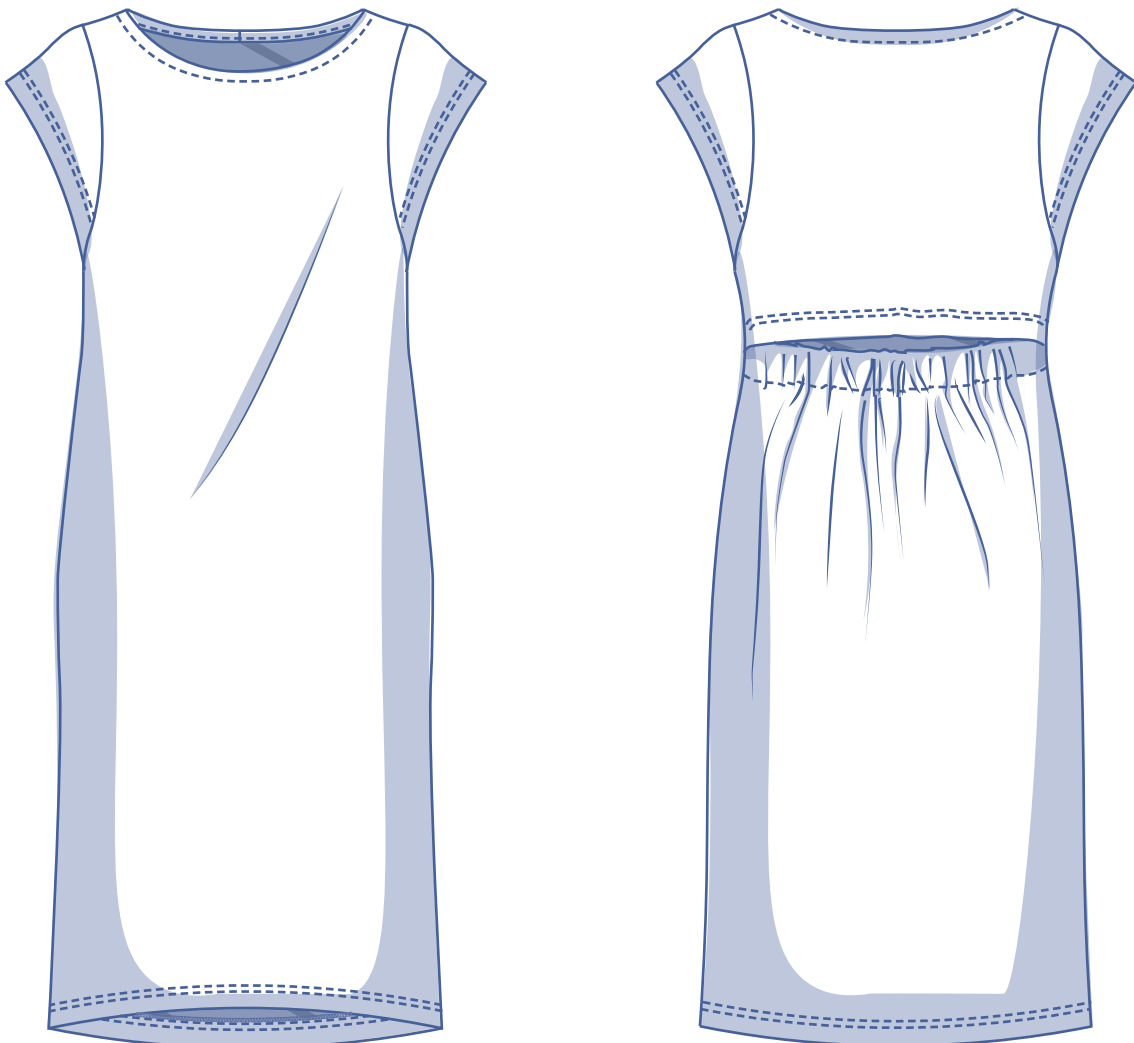

size chart (in cm)

size	4	6	8	10	12	14	16	18	20	22	24	26	28	30	32
body height	160	164	166	167	168	169	170	171	172	172	172	172	172	172	172
B (bust)	76	80	84	88	92	96	100	104	110	116	122	128	134	140	146
H (hips)	86	90	94	97	100	103	106	109	115	120	125	130	135	140	145

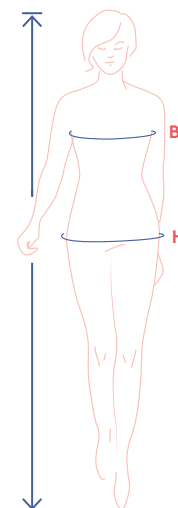

Choose your size based on your **bust measurement**. If your hip measurements are wider than those in the size chart, check the hip measurements in the chart below to see if there's enough room or whether the pattern needs to be altered. It's easy to do. Simply trace the line of the one size instead of the other.

pattern measurements (in cm)

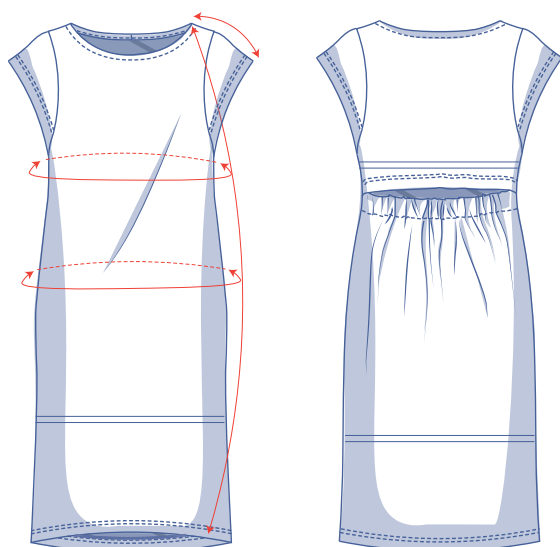

This chart's measurements are the pattern measurements based on the fabric type and serve as a reference. Ease has been added to the width measurements (in addition to the exact body measurements) for a more comfortable fit. Alena is designed to have a **relaxed cut**. Depending on the preferred cut, you could decide to go a size smaller or larger than the recommended size.

==== shorten or lengthen the pattern here

size	4	6	8	10	12	14	16	18	20	22	24	26	28	30	32
length	115	115.5	116.25	116.75	117.25	117.75	118.25	119	120.75	121.5	122.25	123	124	124.75	125.5
sleeve length*	19.5	19.75	20.25	20.5	20.75	21	21.25	21.75	22	22.5	22.75	23.25	23.75	24	24.5
bust	76	80	84	88	92	96	100	104	110	116	122	128	134	140	146
hips	90.75	93.75	96.75	99.75	102.75	105.75	108.75	111.75	117.75	124.25	130.5	137	143.5	149.75	156.25

* Including shoulder length.

Compare the stated lengths to the measured or desired lengths. **Lengthen** or **shorten** the dress by cutting the pattern pieces along the indicated double lines. Then either increase the distance between the cut pieces by the desired amount (to lengthen) or overlap the pieces (to shorten). Make sure that the CF and CB lines and the side seams are always straight.



IMPORTANT

Adjust the amount of fabric to be used based on these alterations.

notions



- Thread
- Iron-on interfacing: max. 15 cm
- Elastic (width 4 cm): see table
- Bias tape: see table
- Fabric: see table

elastic		4	6	8	10	12	14	16	18	20	22	24	26	28	30	32
length*	cm	30	31	32	33	34	35	36	37	39	41	43	45	48	50	52

* The elastic measurements (including seam allowance) are only indicative and depend on the type of elastic. To determine the desired length, thread the elastic through the casing. Add 2 x 1 cm seam allowance to the measured length.

bias tape		4	6	8	10	12	14	16	18	20	22	24	26	28	30	32
length	cm	61.25	62.5	63.5	64.50	65.5	66.5	67.5	68.5	70	71.5	73	74.5	76	77.5	79.25

fabric		4	6	8	10	12	14	16	18	20	22	24	26	28	30	32
fabric width 110 cm	cm	170	170	170	170	290	290	290	295	300	300	310	315	325	330	335
fabric width 140 cm	cm	150	150	170	170	170	170	175	175	175	175	180	305	305	305	310

The corresponding fabric layout can be found on page 6 of these sewing instructions.

fabric advice



The ideal choice is a fabric with a nice drape that isn't too lightweight. Alena looks darling in jersey, e.g. bamboo French terry, viscose jersey, French terry, etc. Woven options that work well include double gauze and chambray.

Proud to be #Sewista

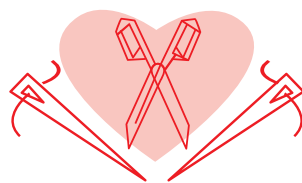

pattern pieces & seam allowances (in cm)

To sew the garment as described in the instructions, draw the illustrated seam allowances around the paper pattern pieces before cutting them out. If you are using a PDF pattern, the pattern can be printed with or without seam allowance.

To find out more, watch the [video](#).

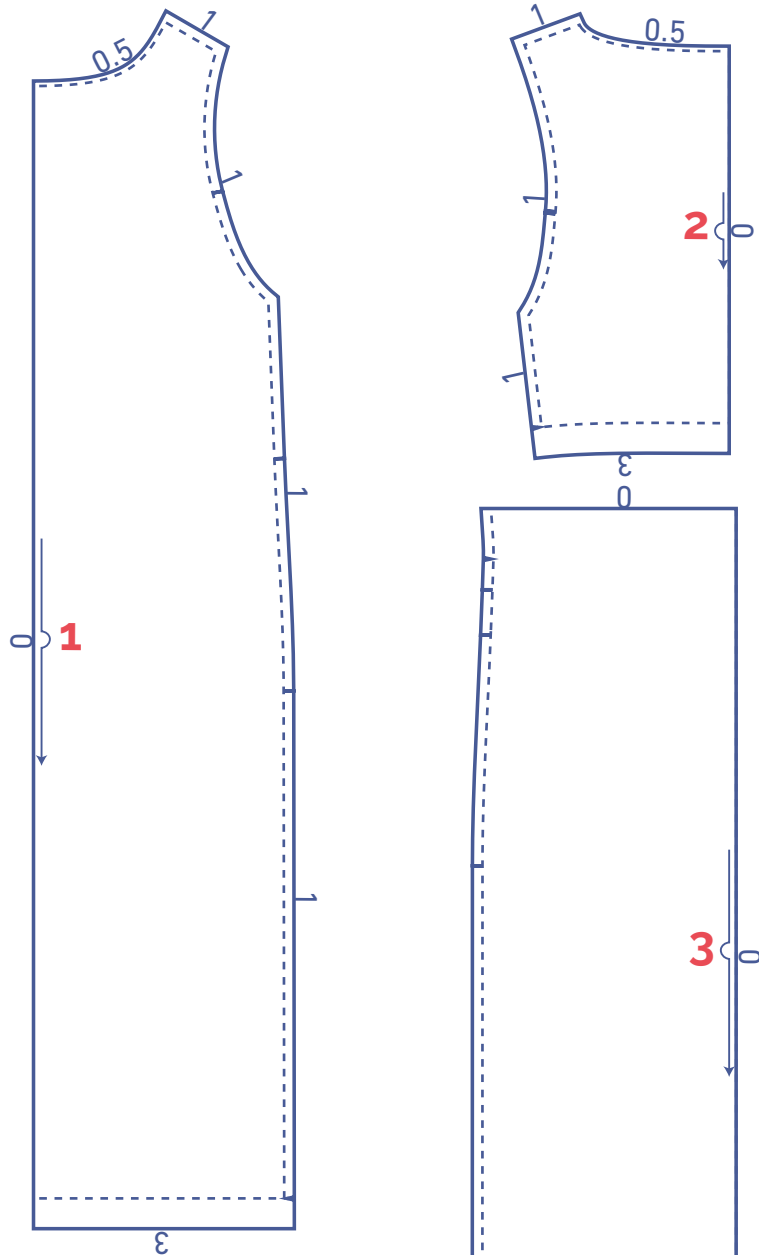

1. front: 1x on fabric fold
2. back bodice: 1x on fabric fold
3. skirt back: 1x on fabric fold
4. sleeve: 2x
5. sleeve facing: 2x

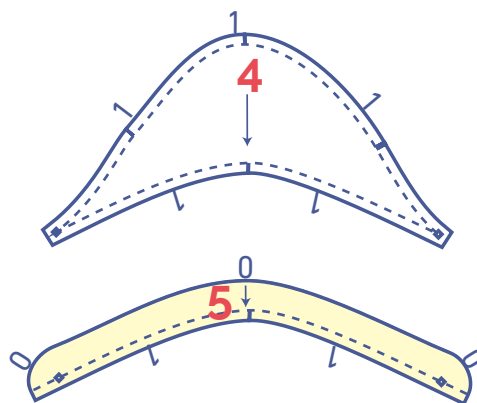

IMPORTANT

The pieces highlighted in light yellow have iron-on interfacing attached to the wrong side.



 material type
 fabric
 iron-on interfacing

fabric layout – solid fabrics
fabric width 110 cm

4 - 10

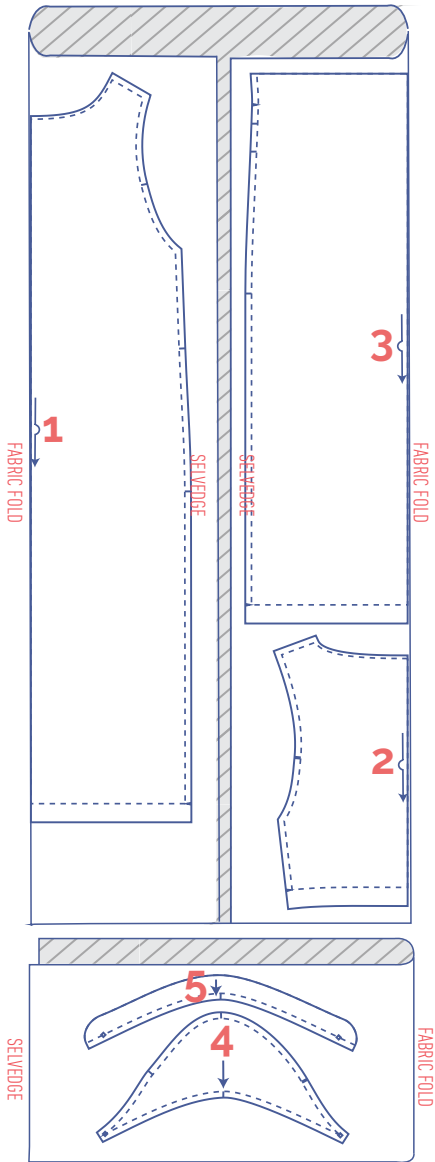

12 - 22

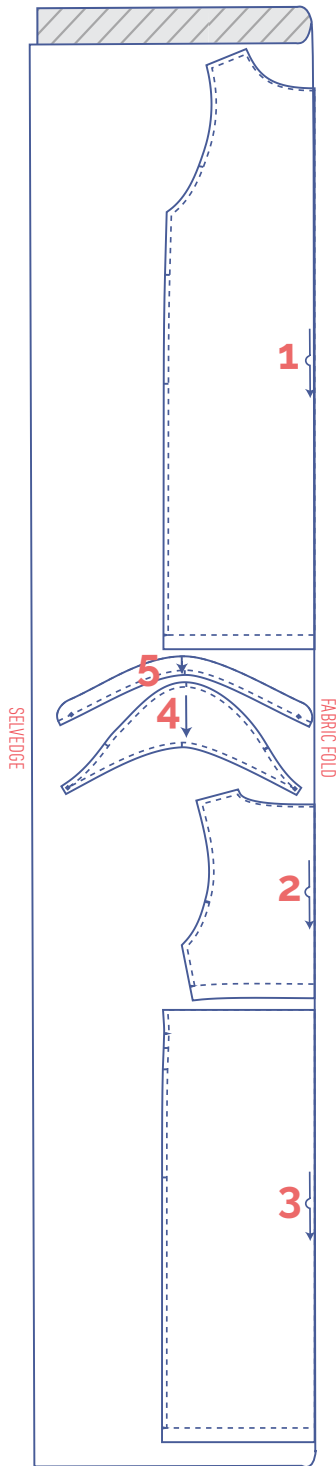

24 - 32

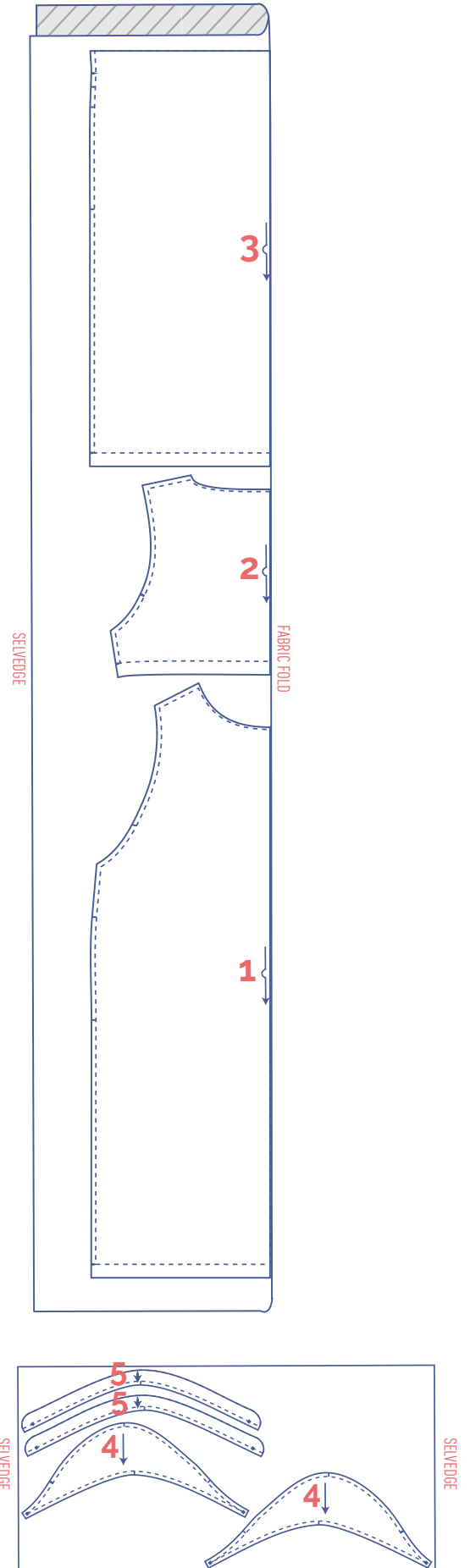

fabric layout – solid fabrics

fabric width 140 cm

4 - 6

8 - 24

26 - 32

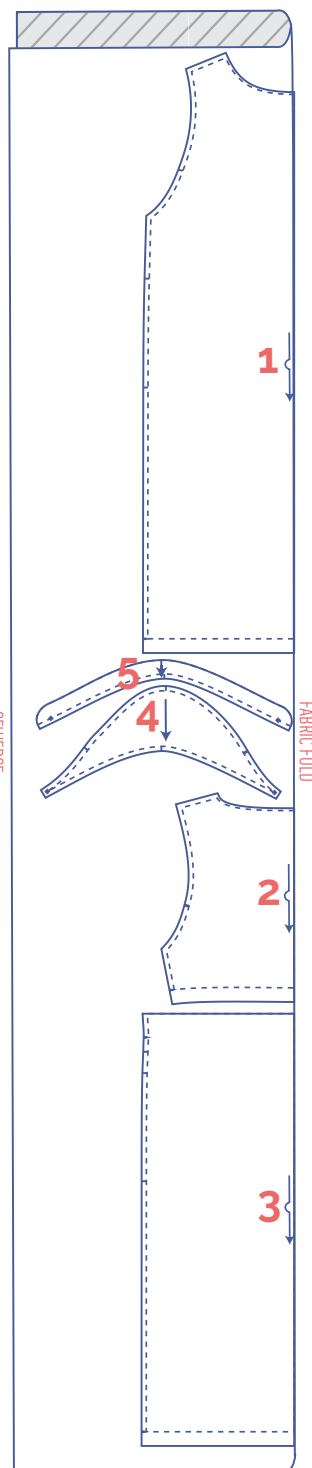
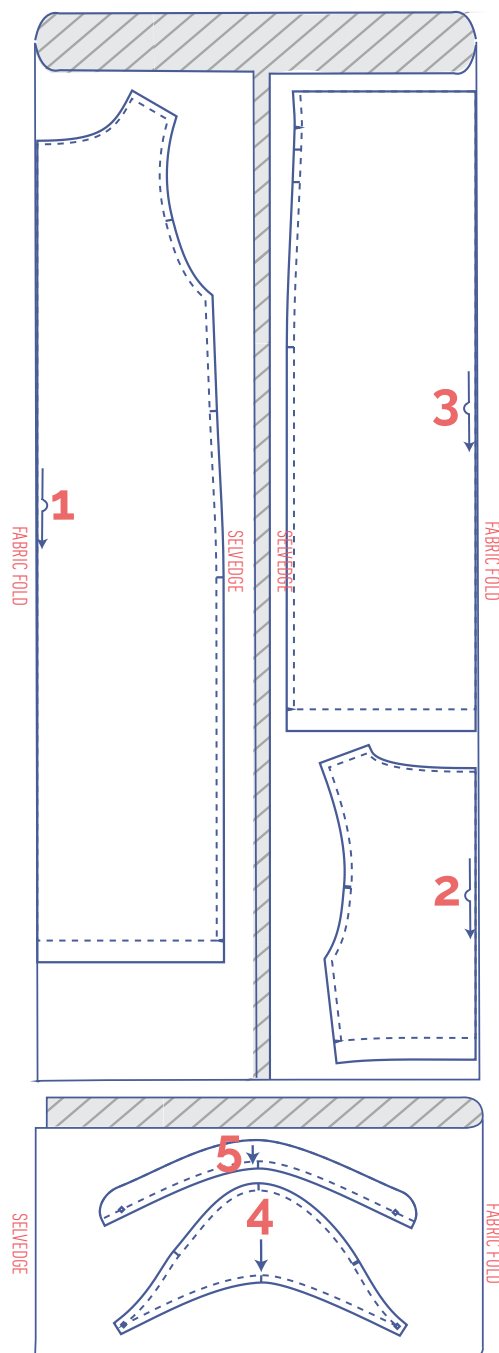
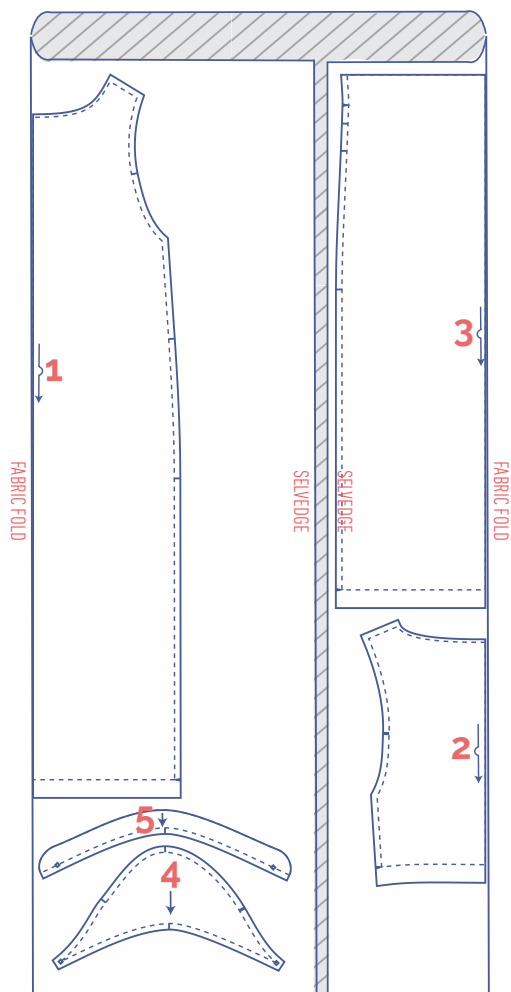

marking pattern pieces

	Notch the pattern paper and fabric at the following points		Mark the following points using marking thread
	single notch		centre point
	double notch		
V	V notch		

sewing instructions



The method used to finish the seams depends on the fabric used.
The pieces are always sewn together with the right sides of the fabric facing, unless stated otherwise.



F front

B back

CF centre front

CB centre back

 right side

 wrong side

 iron-on interfacing

 elastic

 bias tape

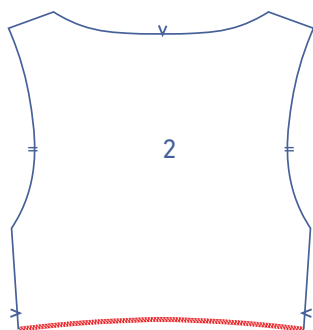
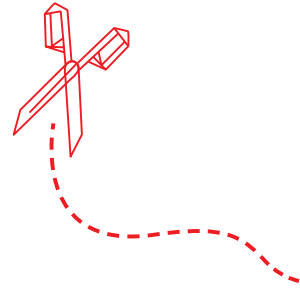

1

Finish the bottom of the back bodice (2) with overlock stitching.

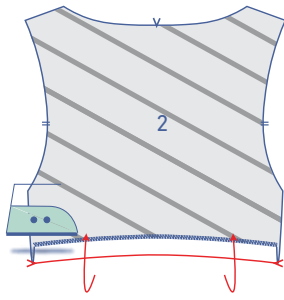

Press the hem allowance up at the V notches.

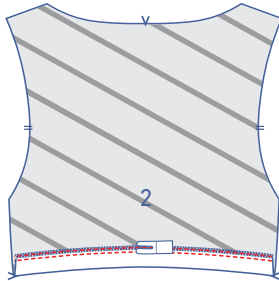

Stitch the hem allowance into place with two rows of topstitching.

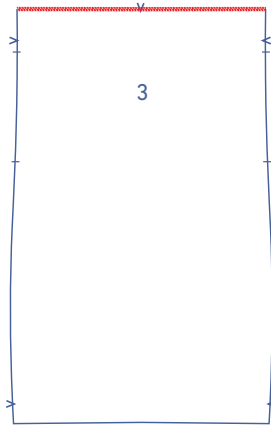

2

Finish the top of the skirt piece back (3) with overlock stitching.

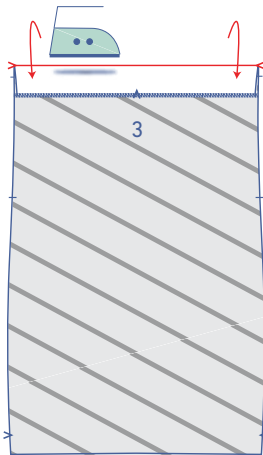

Press the top of the skirt down at the V notches.

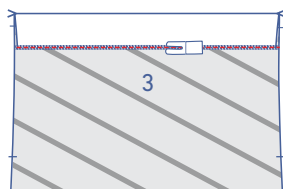

Make the casing by edgestitching the bottom of the facing..

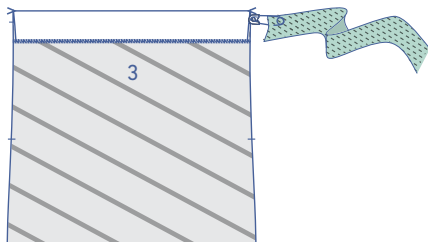

Thread the elastic through the casing through the opening in the side seam.

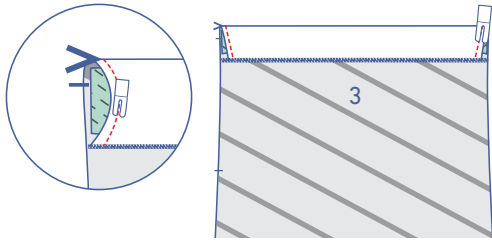

Sew the ends closed at the raw edges.

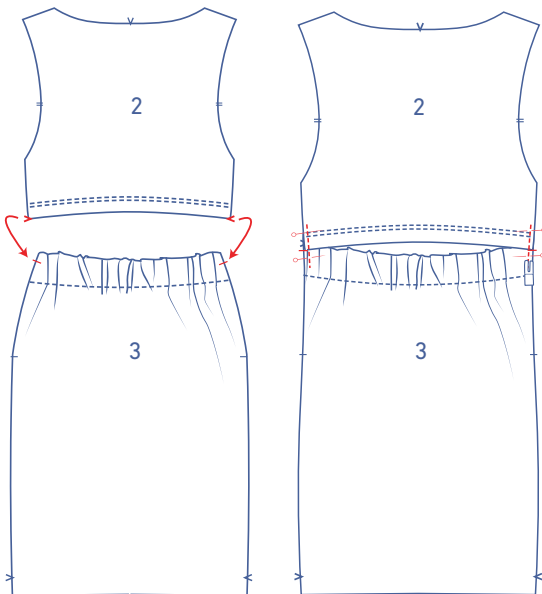

Pin the back bodice to the skirt piece back. The folded edge of the bodice aligns with the single notches in the sides of the skirt. Sew together at presser foot width from the edge.

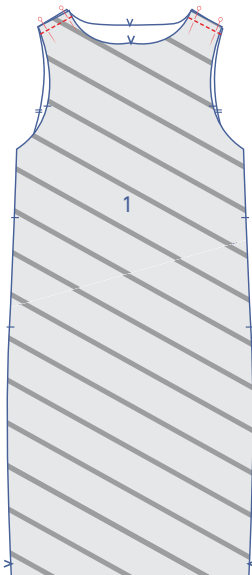

3

Pin and sew the shoulder seams of the front (1) and back together.

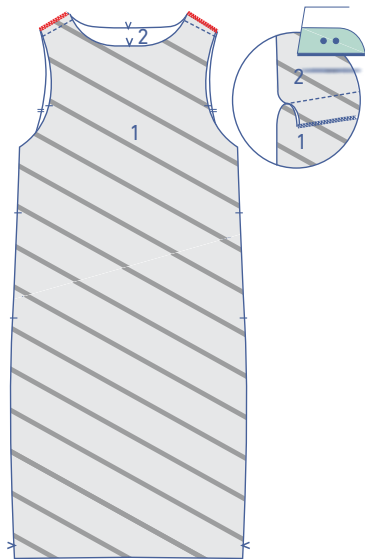

Finish the raw edges with overlock stitching. Press the seam allowance towards the front.

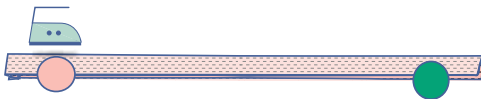
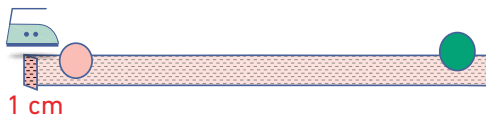

4

Open the pre-pressed bias tape out and press flat.

Press 1 short end of the bias tape 1 cm over towards the wrong side. This pressed short end is marked with a pink circle. The unpressed short end is marked with a green circle.

Press the bias tape in half with the wrong sides of the fabric facing.

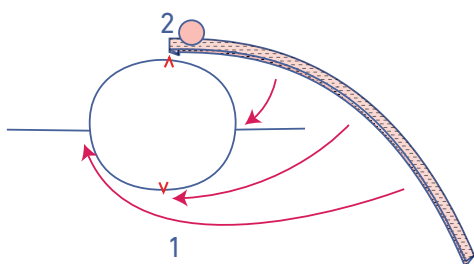

Pin both raw edges of the bias tape to the right side of the neckline. The folded end (pink circle) aligns with the CB.

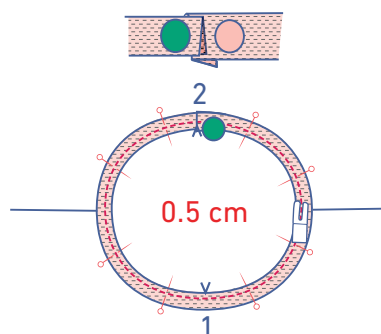

The unfolded end (green circle) of the bias tape should be on top of the folded end. Snip off any excess tape. Sew bias tape into place at 0.5 cm from the raw edge.

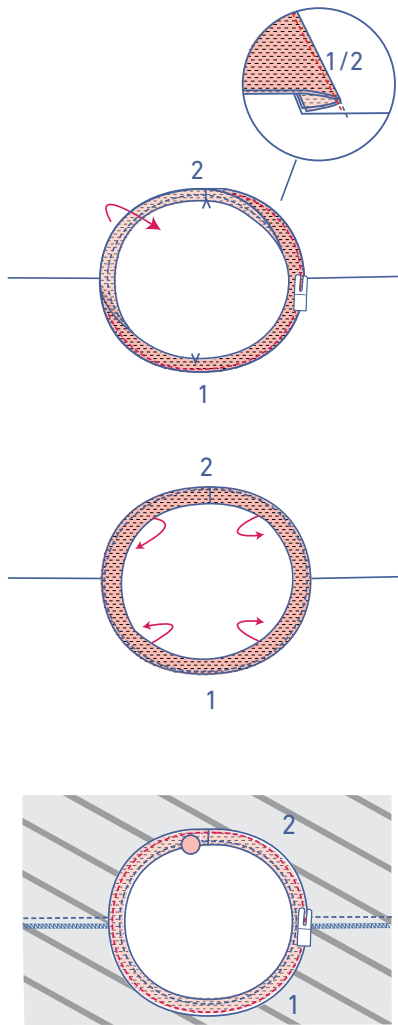

Fold the bias tape and seam allowance over and stitch to the seam allowance underneath, right next to the seam.

Press the bias tape all the way over to the wrong side.

Stitch into place right next to the edge.

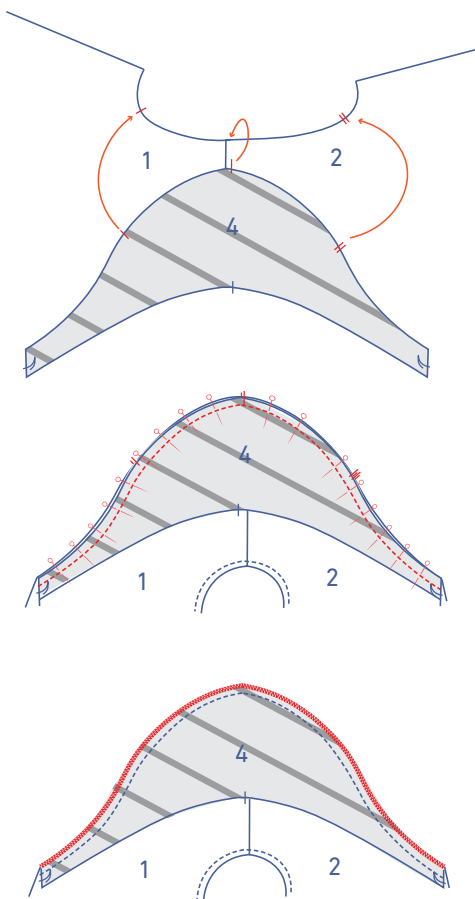

5

Pin and sew the top of the sleeve (= sleeve cap) (4) to the armhole, matching the notches. The single notch marks the front, while the double notch marks the back. The single notch at the top aligns with the shoulder seam.

Finish the raw edges with overlock stitching.

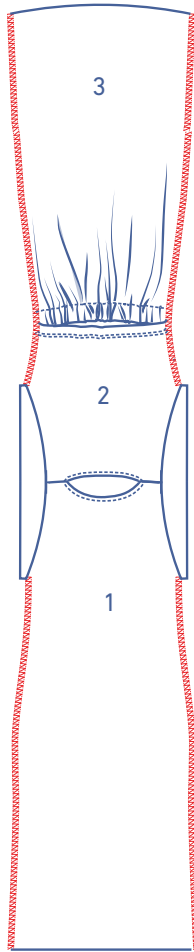

Finish the sides of the front and back with overlock stitching.

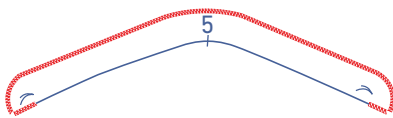

Finish the highlighted contours of the sleeve facing (5) with overlock stitching (refer to diagram).

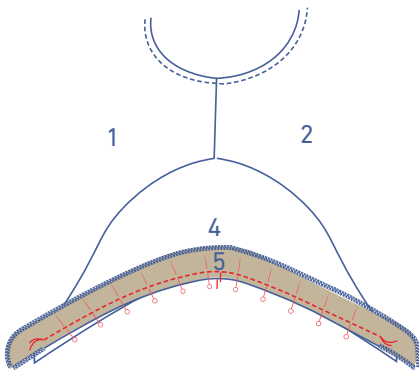

Pin and sew the facing to the bottom of the sleeve from one marking thread to the other.

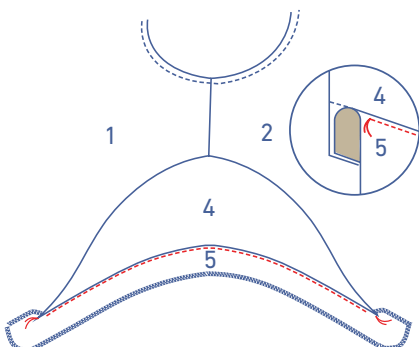

Fold the facing over and stitch to the seam allowance underneath from one marking thread to the other, right next to the seam.

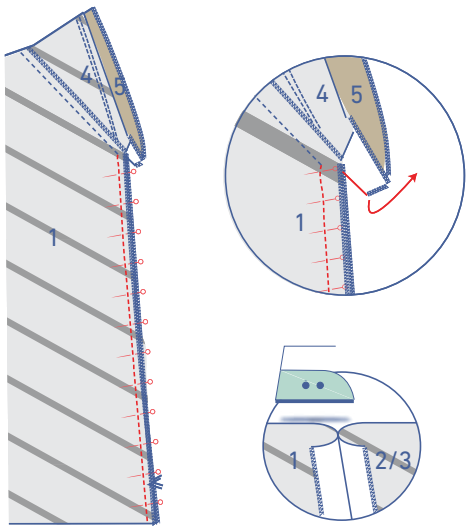

Fold over the bottom of the facing so it is out of the way. Pin and sew the side seams of the front and back. Press the seam allowance open.

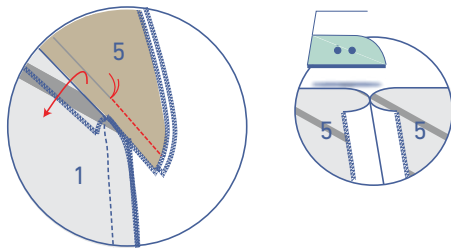

Now pin and stitch the short edge of the facing underneath the marking thread. Press the seam allowance open.

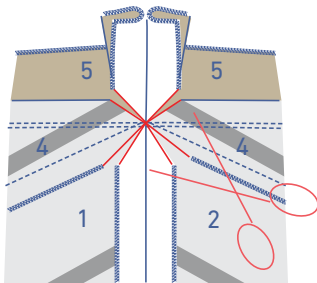

Trim the seam allowances to avoid bunching.

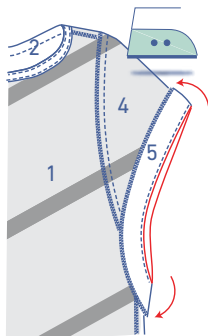

Fold the facing pieces over towards the wrong side and press neatly flat.

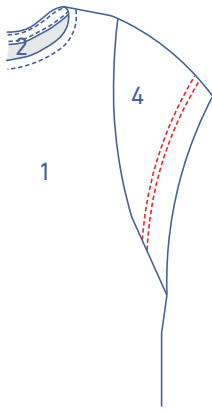

Stitch the facing into place with two parallel rows of topstitching that extend to the seam joining the sleeve and the bodice.

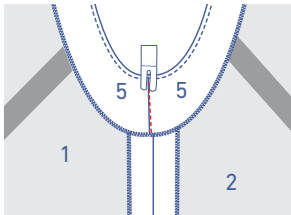

Stitch the facing into place at the front and back along the side seam.

6

Finish the hem based on your fabric type.

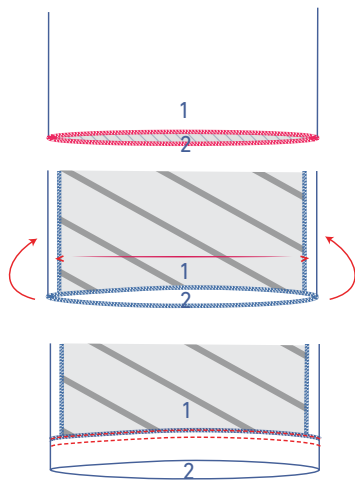

Finish the hem with overlock stitching.

Fold the hem allowance up at the V notches and stitch into place with two rows of topstitching.

OR

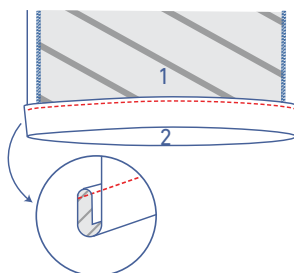

OR

Fold the hem allowance over twice and sew into place right next to the edge.