

# Zita by Fibre ⚡ood



# Zita by Fibre ood



**XS - XXXL**

Zita is the perfect solution for those sultry summer nights and sun-drenched days spent out on the beach. It's done in a jiffy, so you don't have to spend any more time in your sewing room than you want. Hey ... why not set your sewing machine up on your terrace or in the garden? Now, there's an idea! Either way, you'll have this graceful A-line pattern finished in a flash. Short, long or in-between – it's up to you. The scooped neckline and open back are finished with bias tape. And the same goes for the comfortable armholes.

Sew the side seam pockets and the job is done!

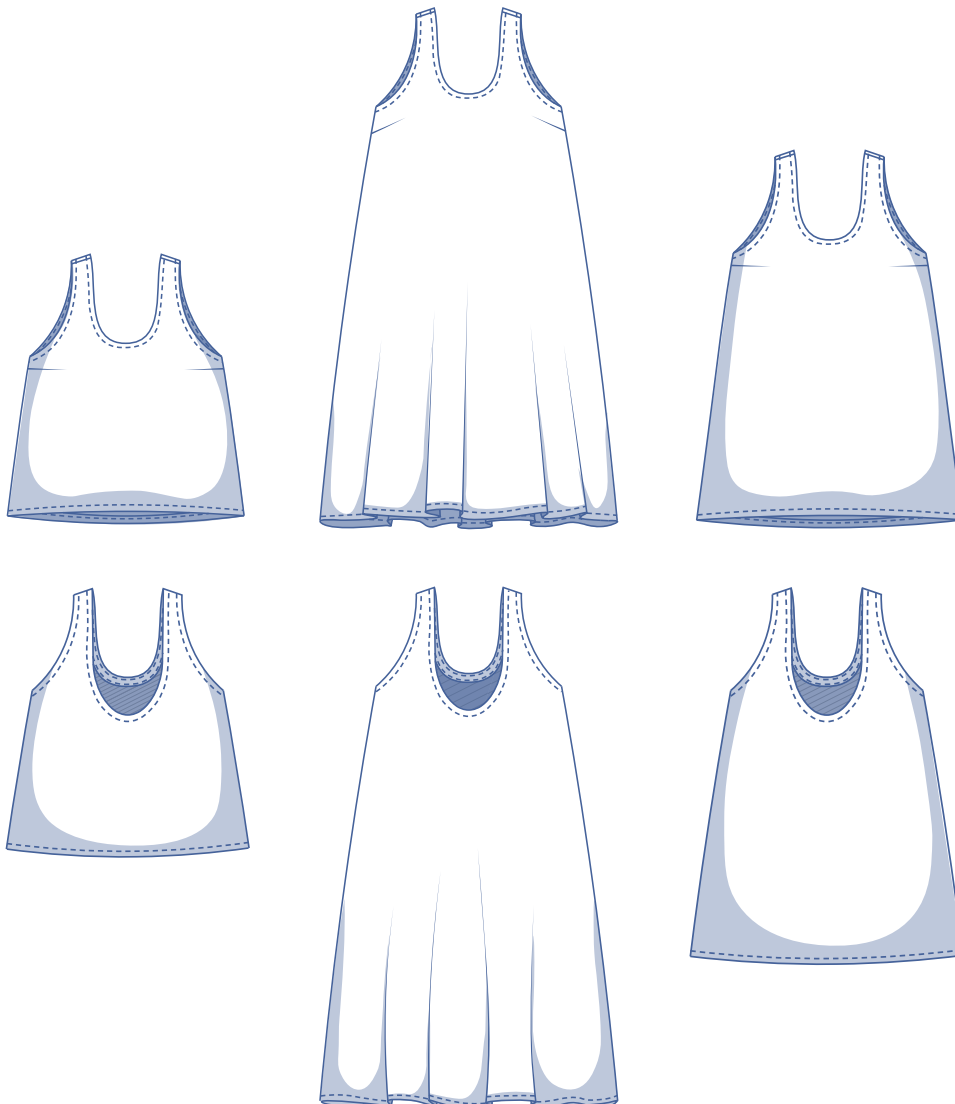

## size chart (in inches)

size	XS		S		M		L		XL		XXL		XXXL		
	0	2	4	6	8	10	12	14	16	18	20	22	24	26	28
body height	5' 25"	5' 38"	5' 45"	5' 48"	5' 51"	5' 54"	5' 58"	5' 61"	5' 64"	5' 64"	5' 64"	5' 64"	5' 64"	5' 64"	5' 64"
B (bust)	29.9	31.5	33.1	34.6	36.2	37.8	39.4	40.9	43.3	45.7	48	50.4	52.8	55.1	57.5
H (hips)	33.9	35.4	37	38.2	39.4	40.6	41.7	42.9	45.3	47.2	49.2	51.2	53.1	55.1	57.1

Choose your size based on the **bust measurement**. If your hip measurements are wider than those in the size chart, check the hip measurements in the chart below to see if there's enough room or whether the pattern needs to be altered. It's easy to do. When tracing the pattern, simply trace from the line of one size to the line of the other.

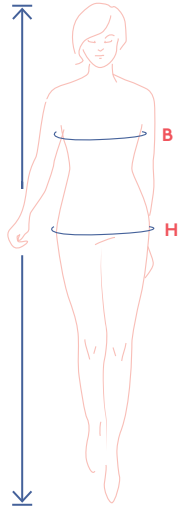

## pattern measurements (in inches)

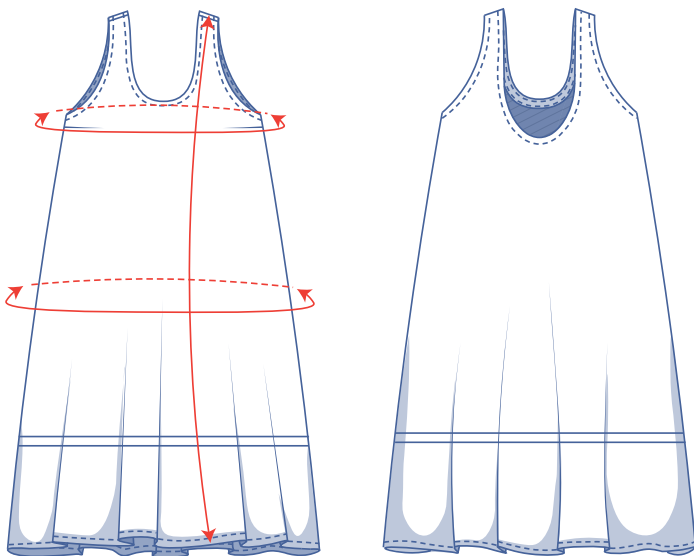

== shorten or lengthen the pattern here

This chart's measurements are the pattern measurements based on the fabric type and serve as a reference. Ease has been added to the width measurements (in addition to the exact body measurements) for a more comfortable fit. Zita is designed to have a **relaxed cut**.

size	XS	S	M	L	XL	XXL	XXXL
length. long dress	46.7	47	47.5	47.9	48.9	49.6	50.2
length. short dress*	31.1	31.6	32	32.8	33.9	34.8	35.5
length. top**	18.6	19.3	20	20.7	21.7	22.5	23.4
bust	34.9	38	41	44.1	47.9	52.6	57.2
hips	51.5	54.6	57.8	60.9	64.9	69.6	74.3

\* Cut pattern pieces 1 and 2 to this length for the short dress.

\*\* Cut pattern pieces 1 and 2 to this length for the top.

Compare the stated lengths to the measured or desired lengths. **Lengthen** or **shorten** the dress by cutting the pattern pieces along the indicated double lines. Then either increase the distance between the cut pieces by the desired amount (to lengthen) or overlap the pieces (to shorten). Make sure that the CF and CB lines and the side seams are always straight.



### IMPORTANT

Adjust the amount of fabric to be used based on these alterations.

## notions

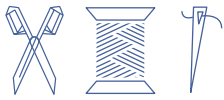

- Thread
- Fabric: see table

fabric use. long dress		XS	S	M	L	XL	XXL	XXXL
fabric width 43"*	yd	4 ¼	4 ½	*	*	*	*	*
fabric width 55"	yd	3 ¾	3 ¾	3 ¾	3 ¾	3 ¾	4 ½	5

The corresponding fabric layout can be found on page 6 of these sewing instructions.

\* Fabric use is not specified because pattern pieces 1 and 2 are too wide to reasonably fit the stated fabric width.

fabric use. short dress		XS	S	M	L	XL	XXL	XXXL
fabric width 43"	yd	2 ¾	2 ¾	3	3	4 ¼	4 ½	4 ¾
fabric width 55"	yd	2 ¾	2 ¾	3	3	3	3 ¼	3 ½

fabric use. top		XS	S	M	L	XL	XXL	XXXL
fabric width 43"	yd	2 ¼	2 ¼	2 ¼	2 ¼	2 ¼	2 ¼	2 ½
fabric width 55"	yd	1 ½	1 ½	2 ¼	2 ¼	2 ¼	2 ¼	2 ½

**fabric advice** The Zita dress calls for a lovely, soft drape fabric. You could select an incredibly drapery fabric such as satin, viscose (crepe) to a moderately fluid drape fabric such as lyocell or chambray. e.g. faux suede. Jacquard or other slightly textured fabrics work as well so long as they are not too thick or stiff.



# Proud to be #Sewista

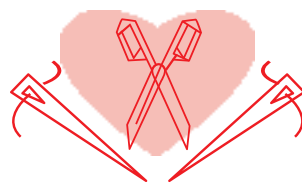

## pattern pieces & seam allowances (in inches)

To sew the garment as described in the instructions, draw the illustrated seam allowances around the paper pattern pieces before cutting them out. If you are using a PDF pattern, the pattern can be printed with or without seam allowance. To find out more, watch the [video](#).

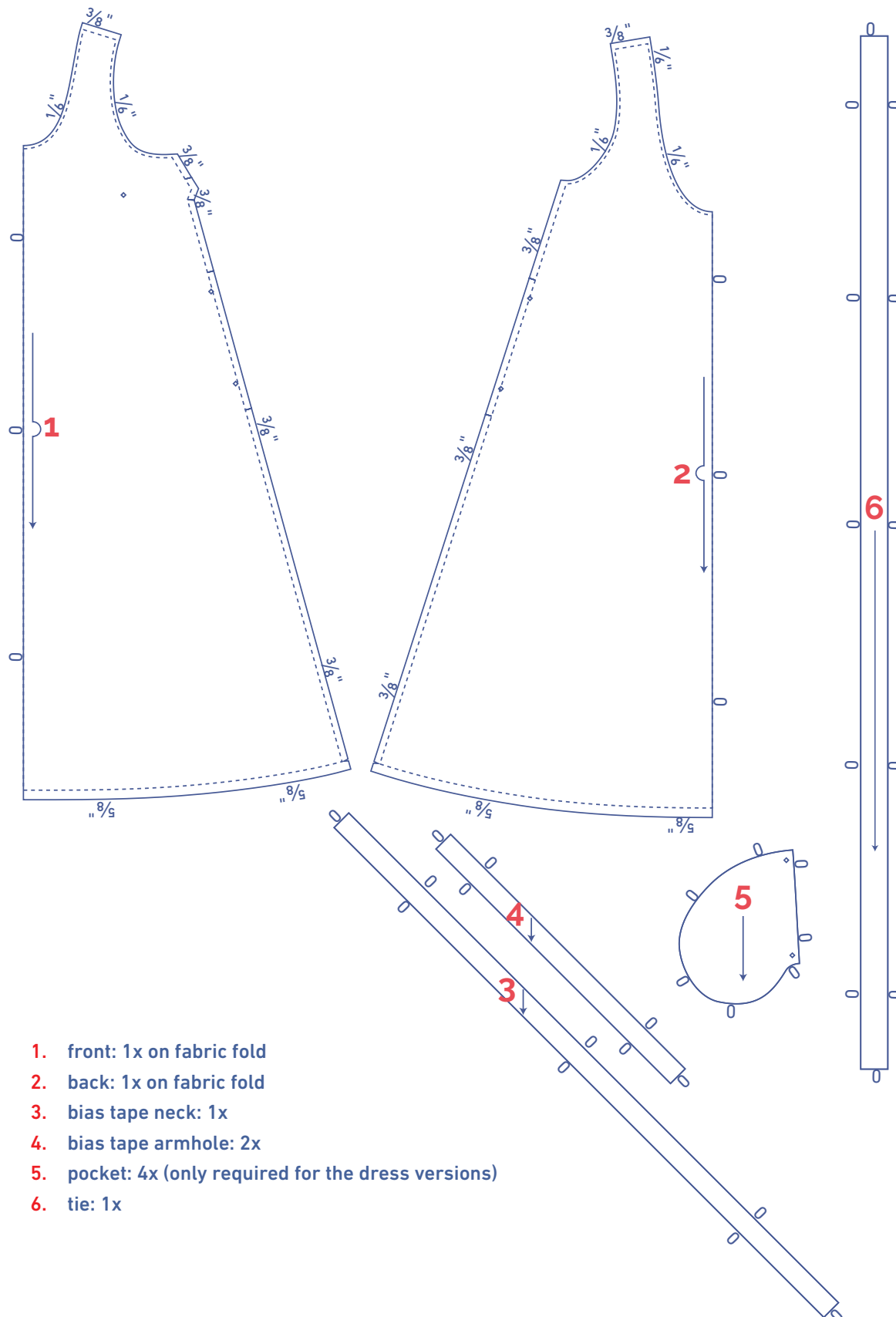

1. front: 1x on fabric fold
2. back: 1x on fabric fold
3. bias tape neck: 1x
4. bias tape armhole: 2x
5. pocket: 4x (only required for the dress versions)
6. tie: 1x

## fabric layout – solid fabrics fabric width 43"

XS - S

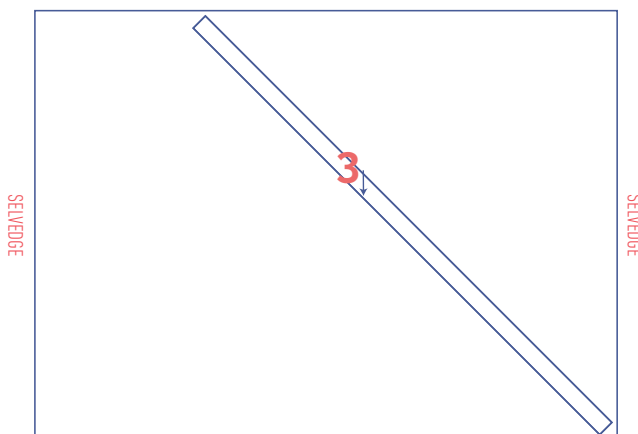
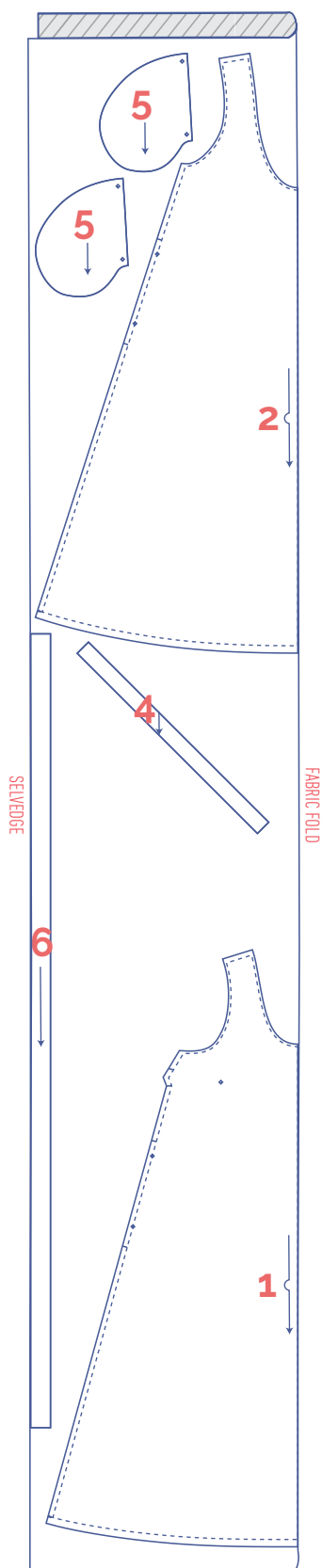

### marking pattern pieces



Notch the pattern paper and fabric at the following points

| single notch

∨ V-notch/fabric fold



Mark the following points with marking thread



centre point

### IMPORTANT

You only need pattern piece 6 once.

# fabric layout – solid fabrics fabric width 55"

XS - XL

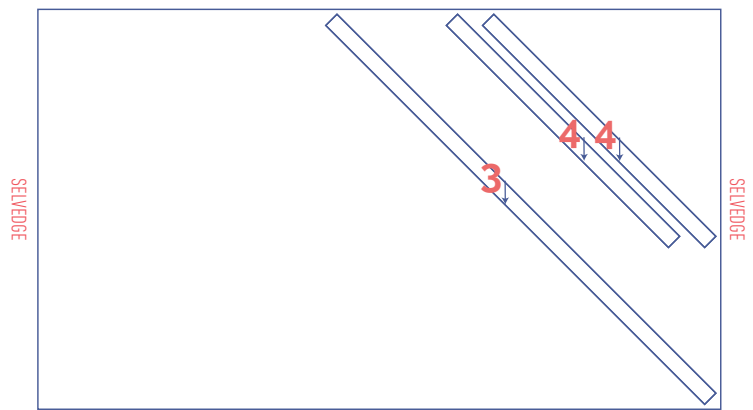
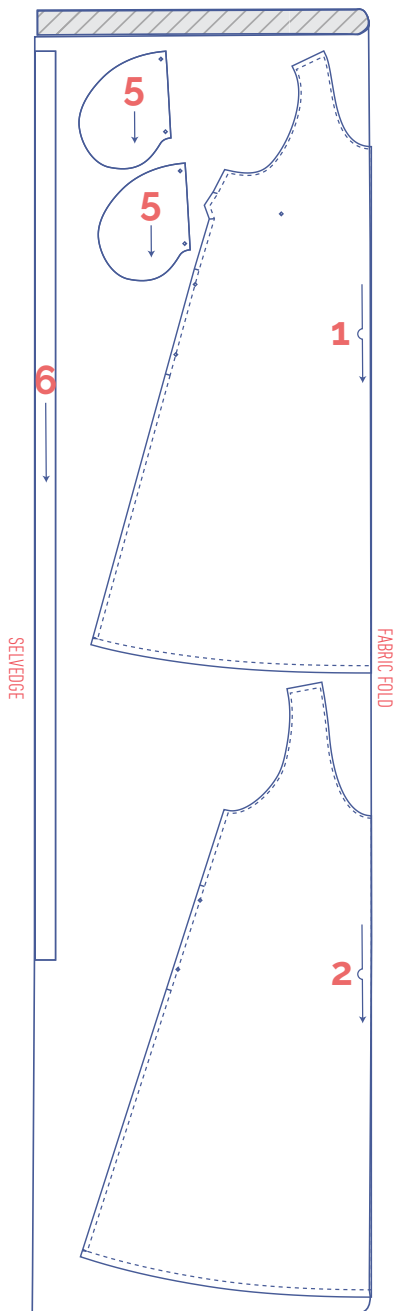

## IMPORTANT

You only need pattern piece 6 once.

XXL - XXXL

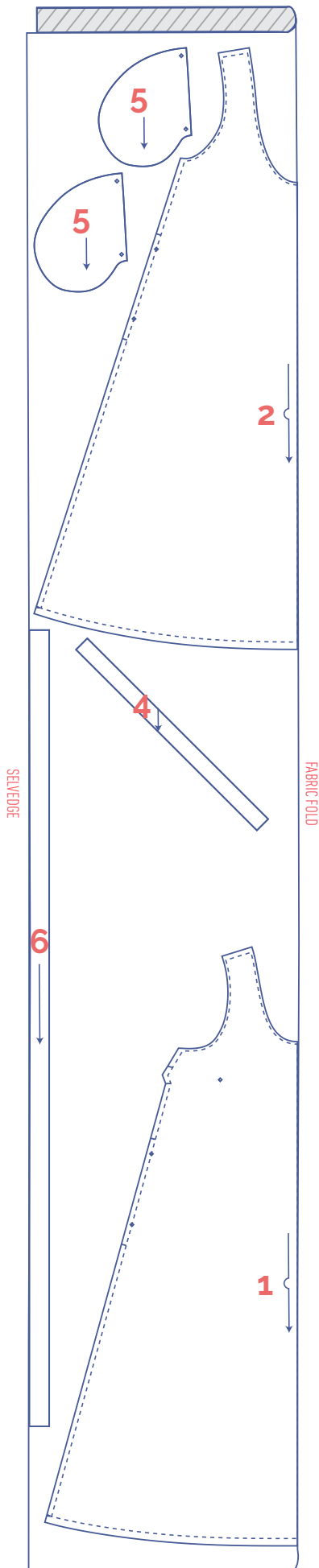

+

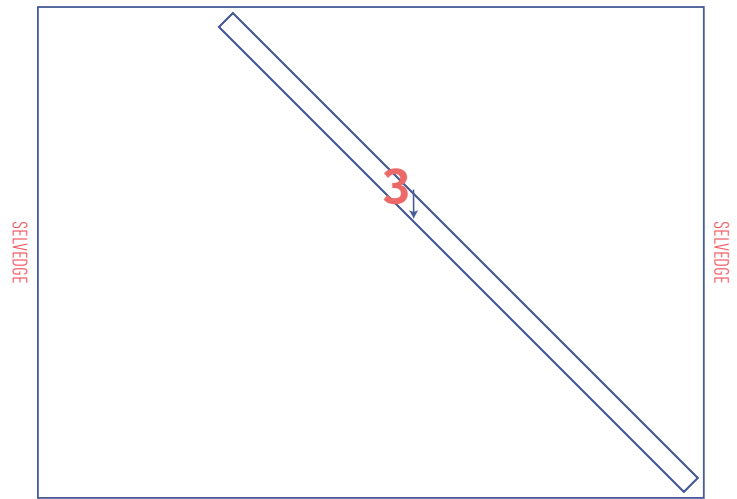

**IMPORTANT**

You only need pattern piece 6 once.

**marking pattern pieces**



Notch the pattern paper and fabric at the following points

| single notch

V V-notch/fabric fold



Mark the following points with marking thread



centre point



# sewing instructions



The method used to finish the seams depends on the fabric used. The pieces are always sewn together with the right sides of the fabric facing unless stated otherwise.



F front

B back

CF centre front

CB centre back

 right side

 wrong side

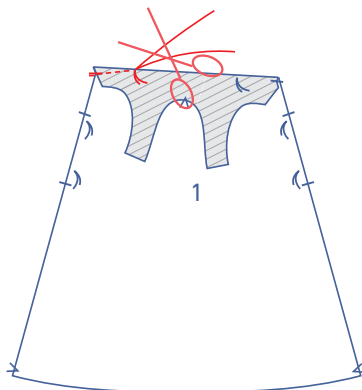
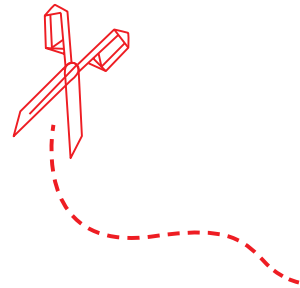

## 1

Fold the bodice together right sides together at the side seam, matching notches. Sew the dart in a slightly curved line towards the marking thread. Sew up to and just past the marking thread, so that you've sewn past the fabric. Snip the threads and tie a knot.

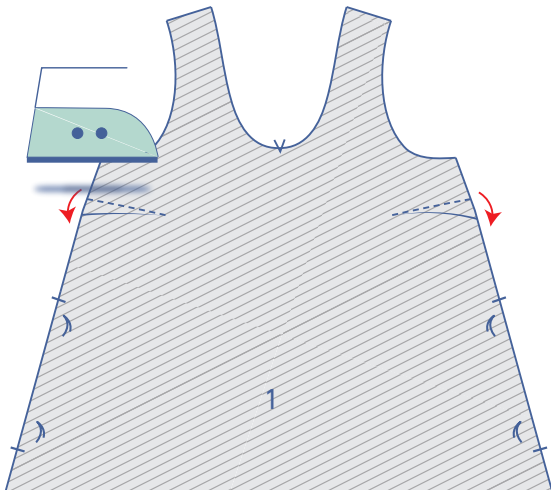

Turn the front over so that the wrong side is facing up.  
Press the dart allowance down.

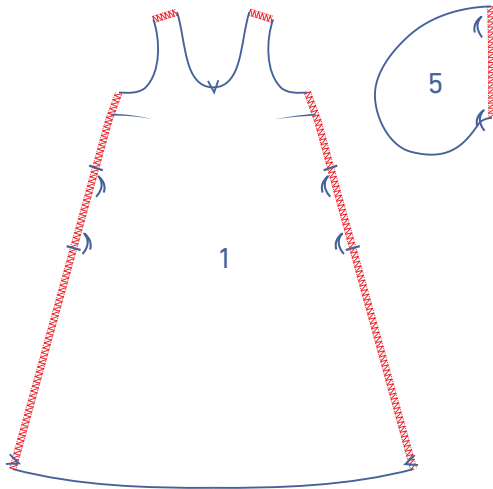

## 2

Finish the edges of the front (1) and back (2) and the straight ends of the pockets (5) with overlock stitching where indicated.

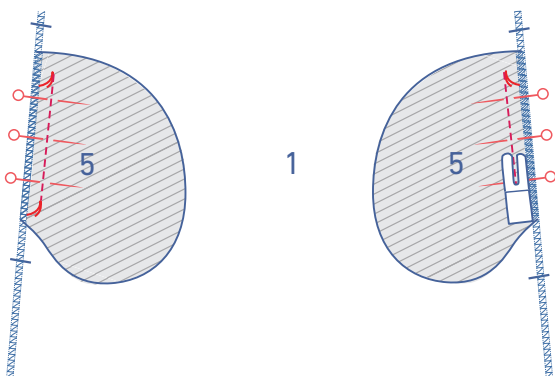
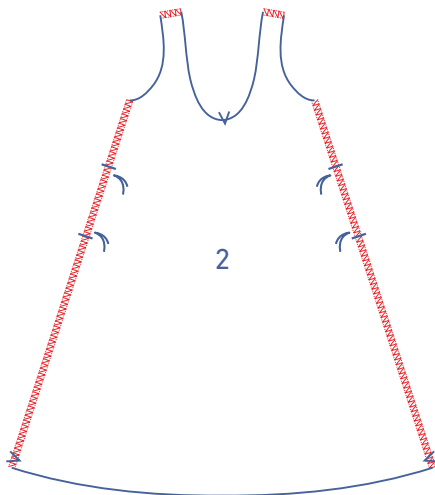

Pin the straight ends of 2 of the 4 pocket pieces to the front, matching the marking threads. Sew into place between the marking threads.

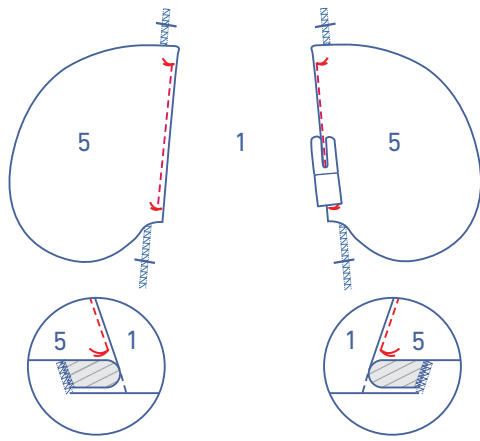

Fold the pocket and seam allowance over and sew the pocket to the seam allowance underneath.

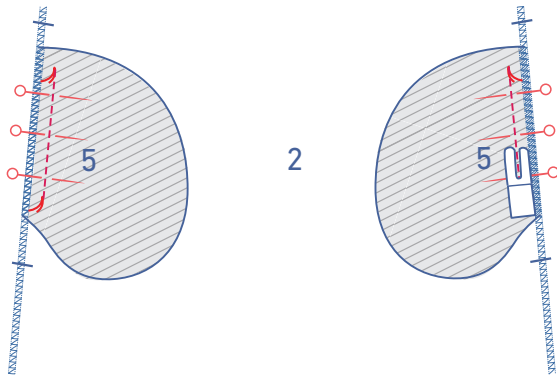

Pin the straight ends of the two remaining pocket pieces to the back, matching the marking threads. Sew into place between the marking threads.

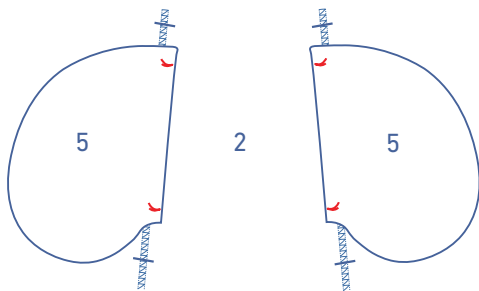

Fold the pocket pieces over.

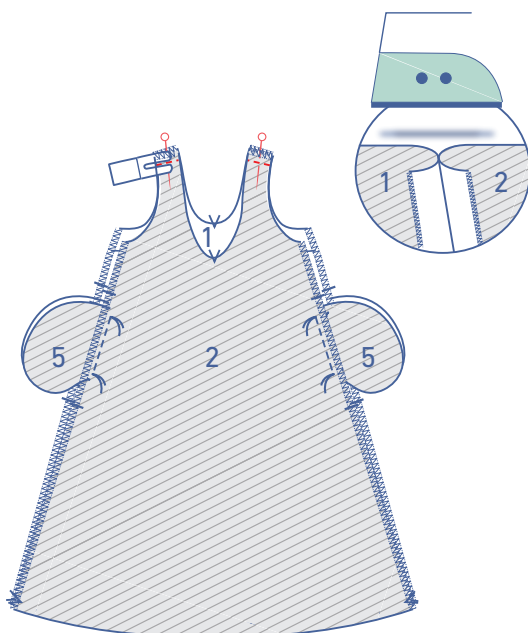

Pin the shoulder seams together and sew. Press the seam allowance open.

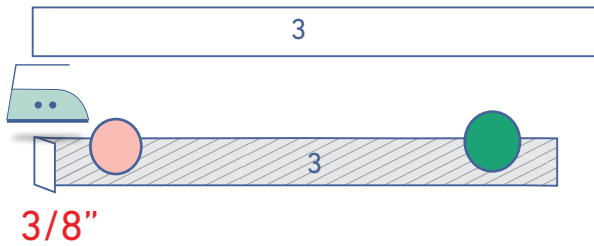

**3**

Press  $\frac{3}{8}$ " of one short end of the neckline bias tape (3) towards the wrong side.

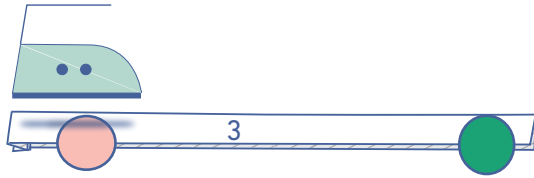

Press the bias tape in half with the long ends together and the wrong sides of the fabric facing each other.

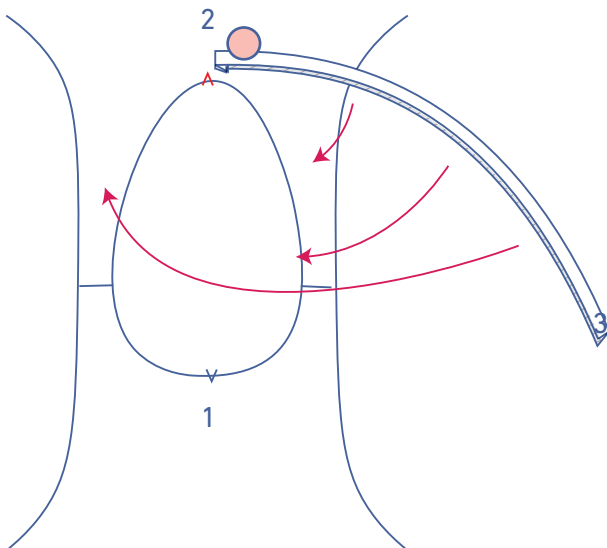

Pin the raw edges of the bias tape to the right side of the neckline. The folded end (pink circle) should line up with the CB.

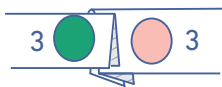

The unfolded end (green circle) of the bias tape should be on top of the folded end.

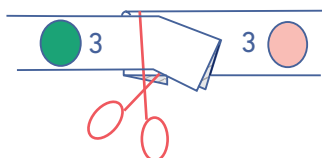
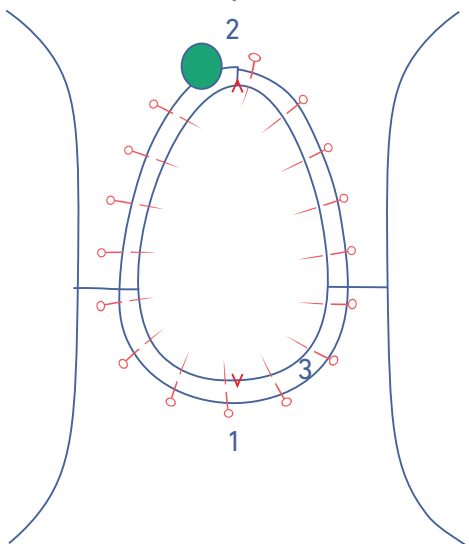

Snip off any excess bias tape. (Stating the precise length isn't possible because the grainline is on the bias. i.e. it will differ according to the fabric type.)

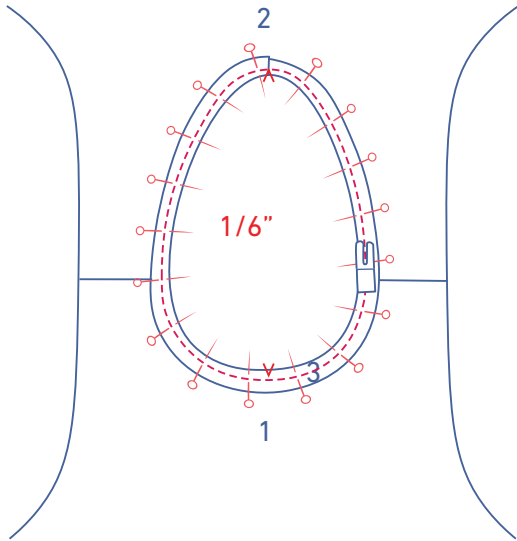

Sew into place at 1/6" from the raw edge.

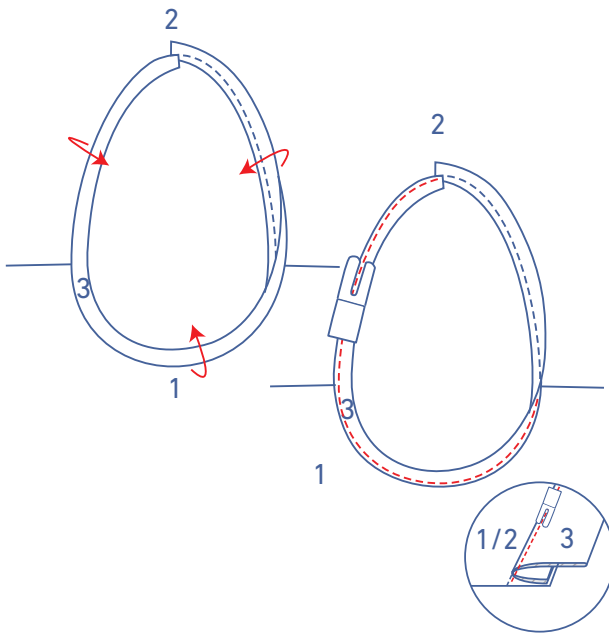

Fold the bias tape and seam allowance over and stitch the bias tape to the seam allowance underneath right next to the seam.

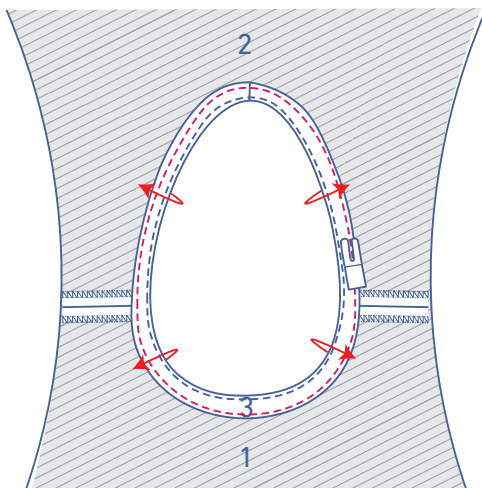

Fold the bias tape all the way over to the wrong side and edgestitch into place.

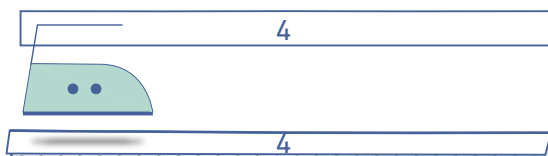

**4**

Press the armhole bias tape (4) in half with the long ends together and the wrong sides of the fabric facing each other.

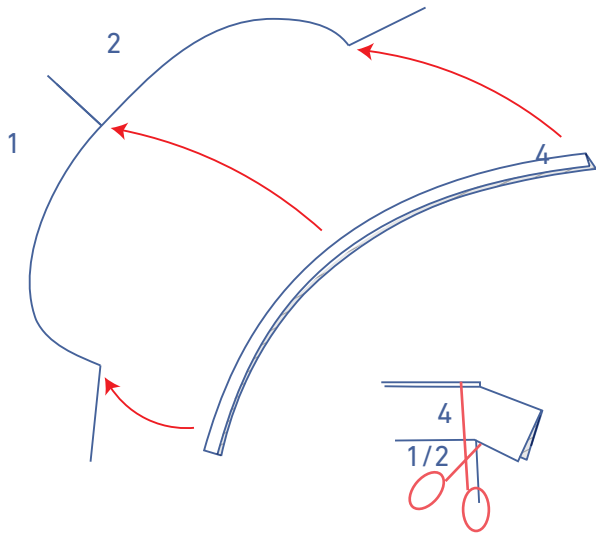

Pin both raw edges of the bias tape to the right side of the armhole.

Snip off any excess bias tape. (Stating the precise length isn't possible because the grainline is on the bias. i.e. it will differ according to the fabric type.)

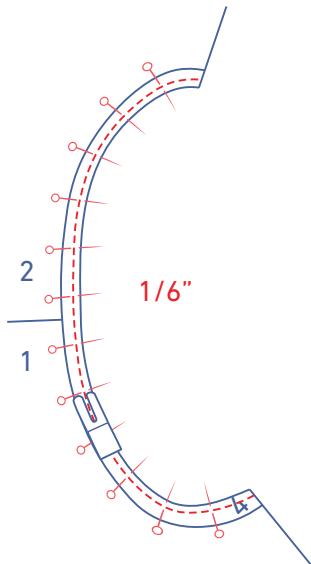

Sew into place at 1/6" from the raw edge.

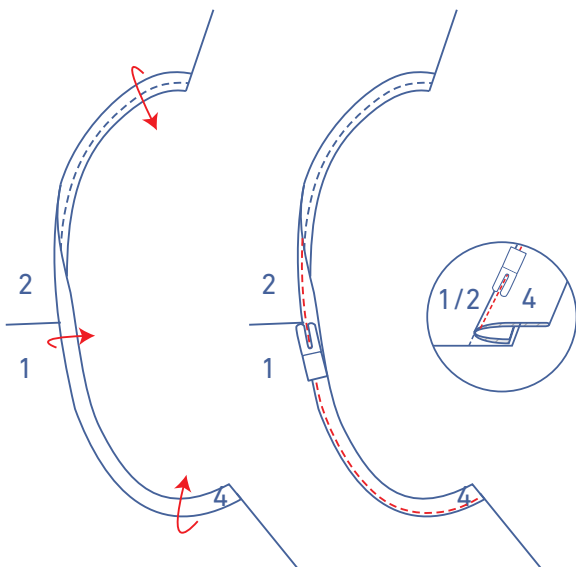

Fold the bias tape and seam allowance over and stitch the bias tape to the seam allowance underneath right next to the seam.

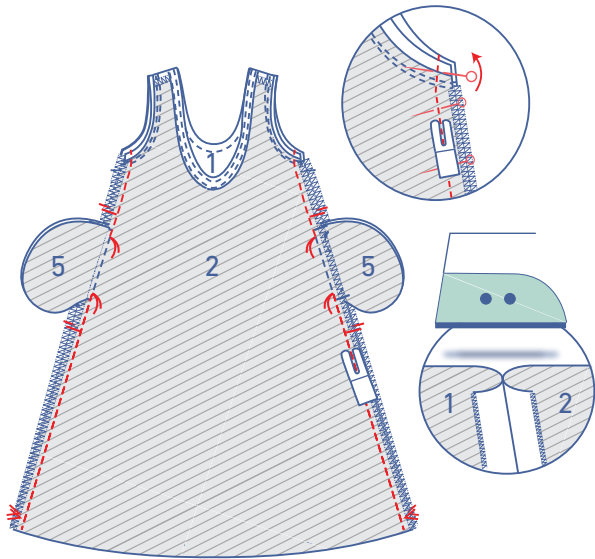

Pin the side seams (with the bias tape folded up) up to the marking threads that mark the top of the pocket opening and sew together. Continue sewing from the next marking thread to the hem.

Press the seam allowance open.

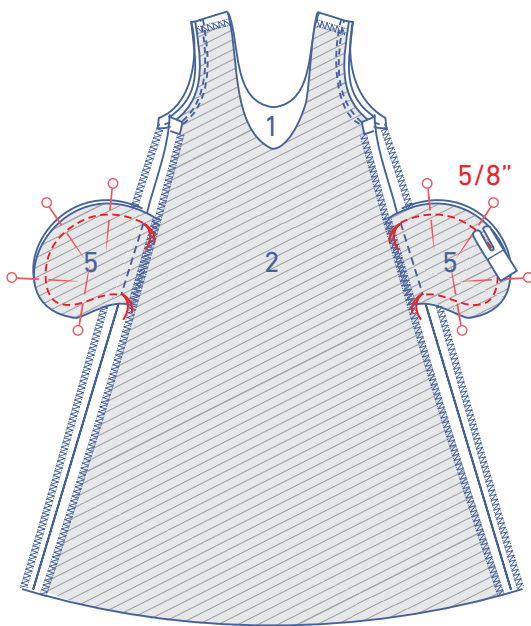

Pin and sew the contours of the pocket pieces together at  $\frac{5}{8}$ ".

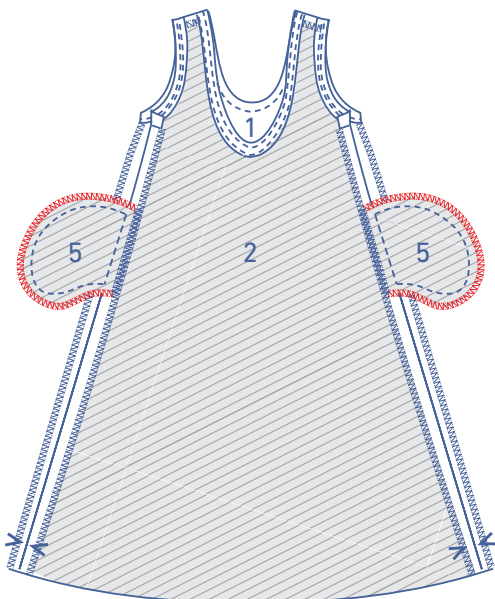

Finish the raw edges with overlock stitching.

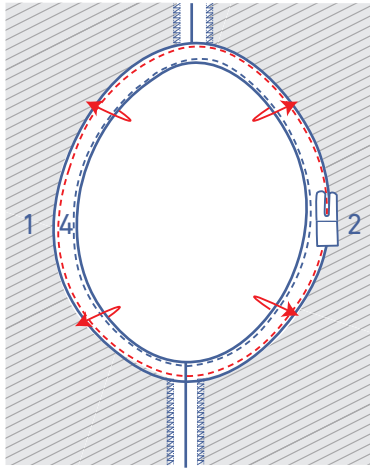

Fold the armhole bias tape all the way around over to the wrong side and edgestitch into place.

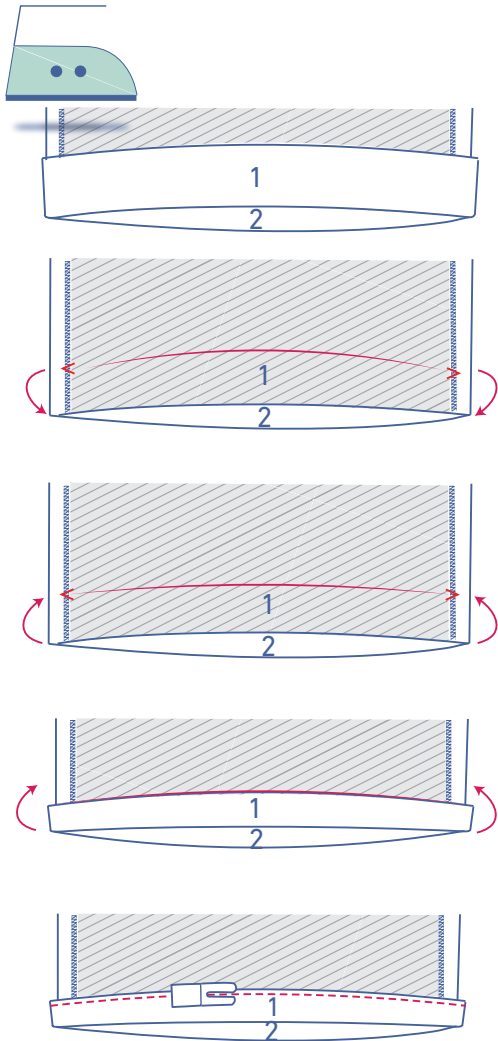

## 5

Press the hem allowance of the dress over at the V notches and open back out.

Fold the raw edge to the pressed fold line and then turn up again.

Edgestitch into place.

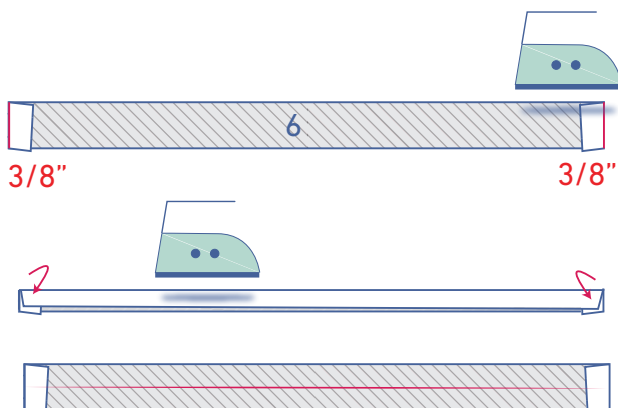

## 6

Press both short ends of the tie (6)  $\frac{3}{8}$ " towards the wrong side.

Fold the tie in half with the long ends together and the wrong sides of the fabric facing.

Open back out.





Press the raw edges all the way across to meet the fold line in the middle.



Stitch into place all the way around, right next to the edge.