

Wanda by Fibre ⚡ood



Wanda by Fibre ood



0 - 28

Wearing the Wanda mini dress is such a treat. It's super laid-back, with an ideal length and three-quarter draped sleeves. Plus there's a lace-up décolleté – leather or not – with metal eyelets to make it lady-of-the-castle worthy. All kinds of fabrics work well with this great pattern. Did we mention there's also side seam pockets? Don't be alarmed if a love-struck troubadour shows up unannounced beneath your bedroom window!



size chart (in inches)

size	0	2	4	6	8	10	12	14	16	18	20	22	24	26	28
body height	5' 25"	5' 38"	5' 45"	5' 48"	5' 51"	5' 54"	5' 58"	5' 61"	5' 64"	5' 64"	5' 64"	5' 64"	5' 64"	5' 64"	5' 64"
B (bust)	29.9	31.5	33.1	34.6	36.2	37.8	39.4	40.9	43.3	45.7	48	50.4	52.8	55.1	57.5
H (hips)	33.9	35.4	37	38.2	39.4	40.6	41.7	42.9	45.3	47.2	49.2	51.2	53.1	55.1	57.1

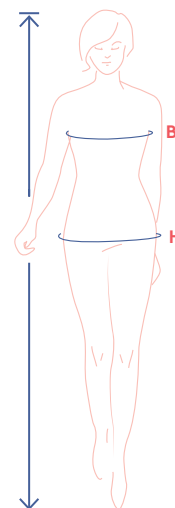

Choose your size based on your **bust measurement**. Is your hip measurement wider than what's listed in the size chart? If so, check the hem circumference in the size chart below to check whether there is enough room or whether the pattern needs to be altered. It's easy to do. When tracing the pattern, simply trace from the line of one size to the line of the other.

pattern measurements (in inches)

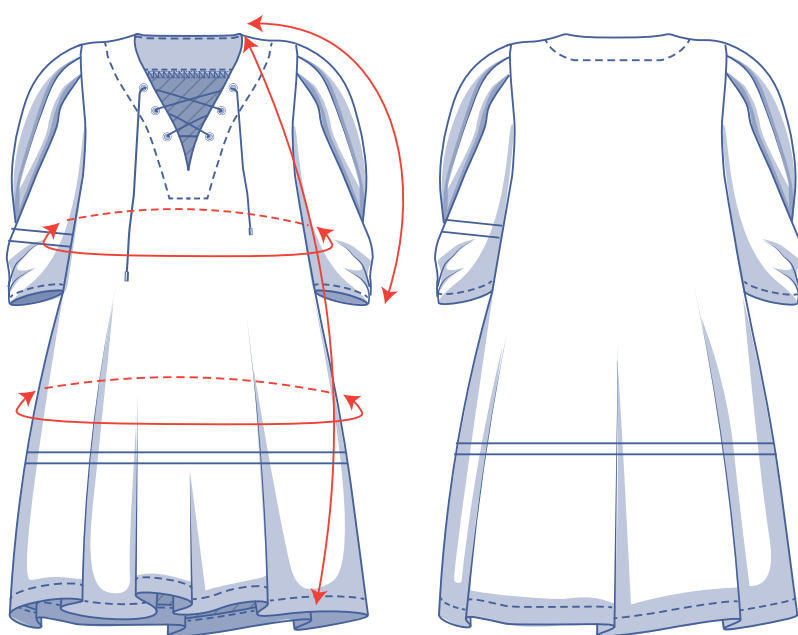

== shorten or lengthen the pattern here

This chart's measurements are the pattern measurements based on the fabric type and serve as a reference. Ease has been added to the width measurements (in addition to the exact body measurements) for a more comfortable fit. Wanda is designed to have a **comfortable fit**. Depending on the preferred cut, you could decide to go a size smaller or larger than the recommended size.

size	0	2	4	6	8	10	12	14	16	18	20	22	24	26	28
length	35.30	35.50	35.70	36.00	36.20	36.40	37.40	37.60	39.10	39.40	39.70	40.10	40.40	40.70	41.00
top length*	23.90	24.20	24.50	24.80	25.10	25.40	25.70	26.00	26.40	26.70	27.10	27.50	27.90	28.30	28.70
sleeve length**	21.00	21.30	21.50	21.70	21.90	22.20	22.40	22.60	23.10	23.40	23.70	23.90	24.20	24.40	24.70
bust	33.90	35.50	37.00	38.60	40.10	41.70	43.20	44.80	47.10	49.50	51.80	54.10	56.50	58.80	61.10
hips	45.60	47.20	48.80	50.40	52.00	53.60	55.20	56.90	59.30	61.70	64.10	66.50	68.90	71.30	73.70

* If you prefer to make the Wanda top, shorten pattern pieces 1 and 2 to this length.

** Including the shoulder length.

Compare the stated lengths to the measured or desired lengths. **Lengthen** or **shorten** the dress and/or the sleeves by cutting the pattern pieces at the indicated double lines. Then either increase the distance between the cut pieces by the desired amount (to lengthen) or overlap the pieces (to shorten). Make sure that the CF and CB lines and the side seams are always straight.



IMPORTANT

Adjust the amount of fabric to be used based on these alterations.

notions



- Thread
- Iron-on interfacing: max. 14"
- Cord/tie: this is optional. You could also use the pattern piece to make your own tie.
- Eyelets (Ø 1/6"): 6
- Fabric: see table

dress fabric		0	2	4	6	8	10	12	14	16	18	20	22	24	26	28
fabric width 43"	yd	2 ¾	2 ¾	2 ¾	2 ¾	3	3	3	3	3 ½	3 ½	3 ¾	3 ¾	3 ¾	4 ¼	4 ¼
fabric width 55"	yd	2 ½	2 ½	2 ½	2 ½	2 ¾	2 ¾	2 ¾	2 ¾	3	3	3	3	3	3 ¼	3 ¼

The corresponding fabric layout can be found on page 6 of these sewing instructions.

top fabric		0	2	4	6	8	10	12	14	16	18	20	22	24	26	28
fabric width 43"	yd	2	2	2	2 ¼	2 ¼	2 ¼	2 ¼	2 ½	2 ¾	3	3	3	3 ¼	3 ¼	3 ¼
fabric width 55"	yd	1 ½	1 ½	1 ½	1 ½	1 ½	2	2	2	2 ¼	2 ¼	2 ¼	2 ¼	2 ¼	2 ½	2 ½

fabric advice



Wanda looks a treat in all kinds of fabrics, from light and fluid drape to stiff and somewhat heavier fabrics. The drape you select depends on the look you're going for. Drama lovers tend towards stiff corduroy, denim, poplin, or leather(ette). If you prefer something a little more understated, then soft drape materials with minimal texture, e.g. viscose (crepe), lyocell, and satin are all good options. Solid or print, which should it be? With Wanda, anything goes!

Proud to be #Sewista

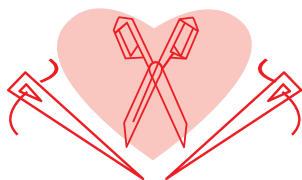

pattern pieces & seam allowances (in inches)

To sew the garment as described in the instructions, draw the illustrated seam allowances around the paper pattern pieces before cutting them out. If you are using a PDF pattern, the pattern can be printed with or without seam allowance. To find out more, watch the [video](#).

1. front: 1x on fabric fold
2. back: 1x on fabric fold
3. sleeve: 2x
4. pocket: 4x
5. tie: 1x (optional since you could also use ready-made cord)
6. facing front: 1x on fabric fold
7. facing back: 1x on fabric fold

IMPORTANT

To make the top, shorten pattern pieces 1 and 2 to your preferred length and then add $\frac{3}{4}$ " of hem allowance. Ignore the pocket markings.

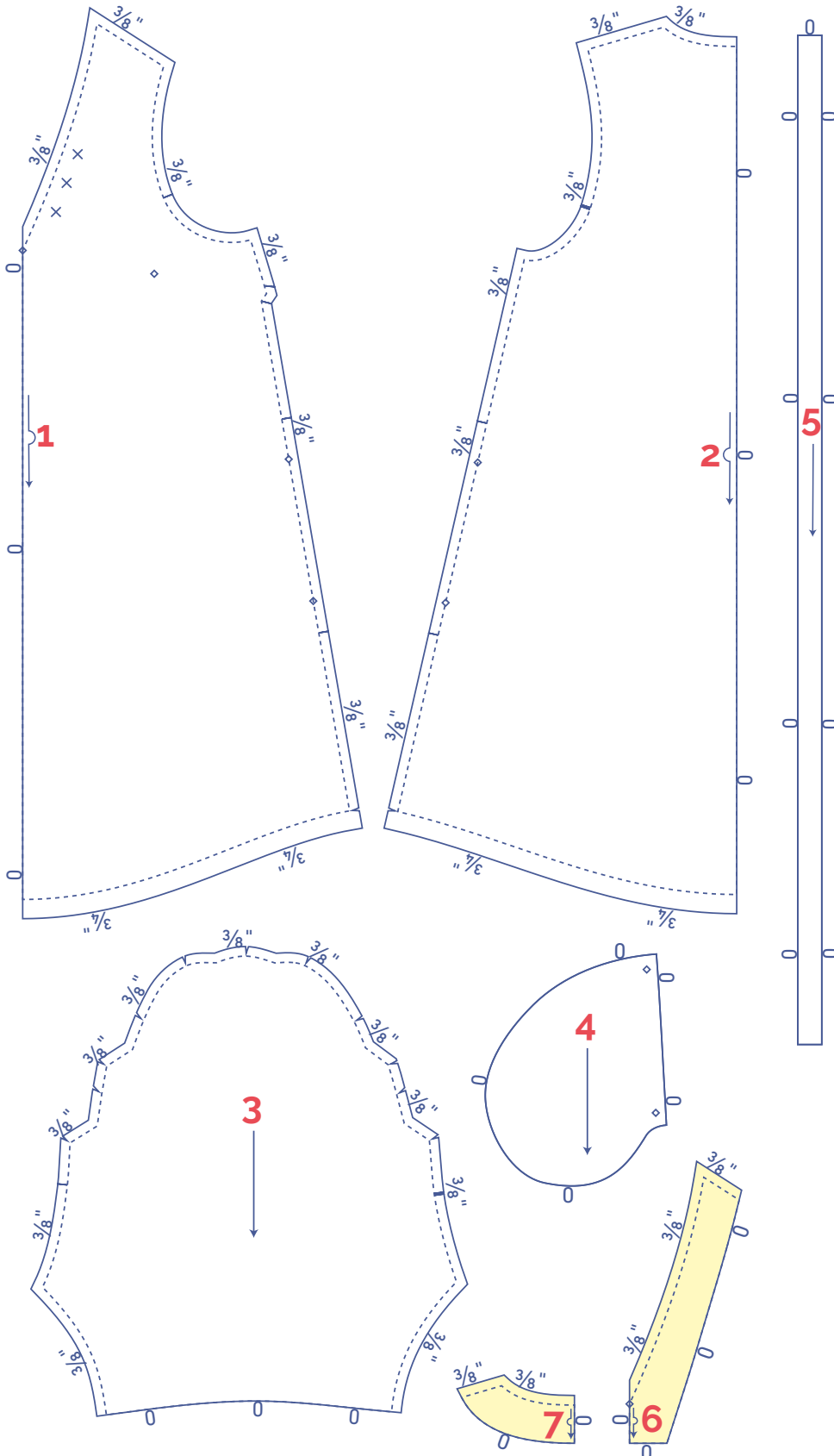

IMPORTANT

The pieces highlighted in light yellow have iron-on interfacing attached to the wrong side.

	material type
	fabric
	iron-on interfacing

fabric layout – solid fabrics
fabric width 43"

0 - 14

IMPORTANT

You only need pattern piece 5 once.

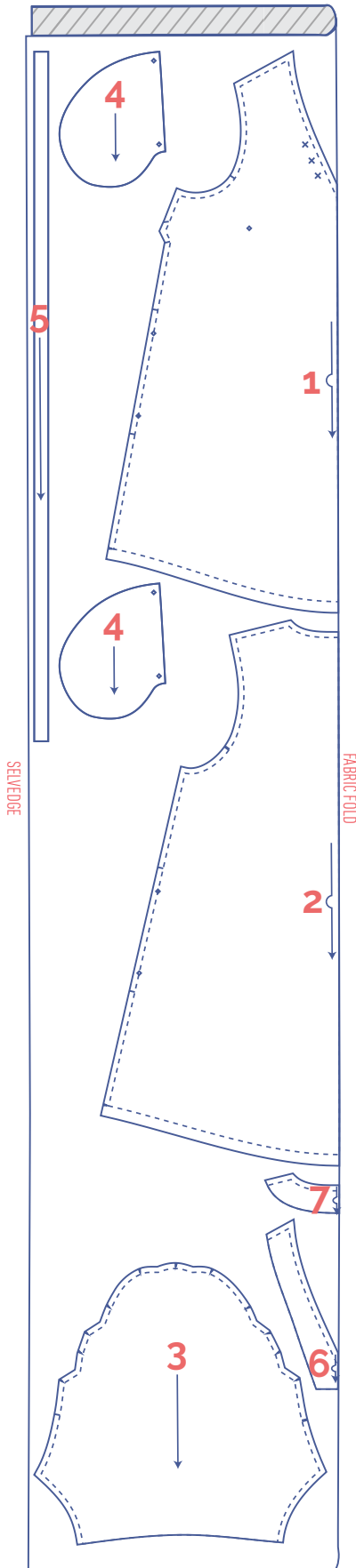

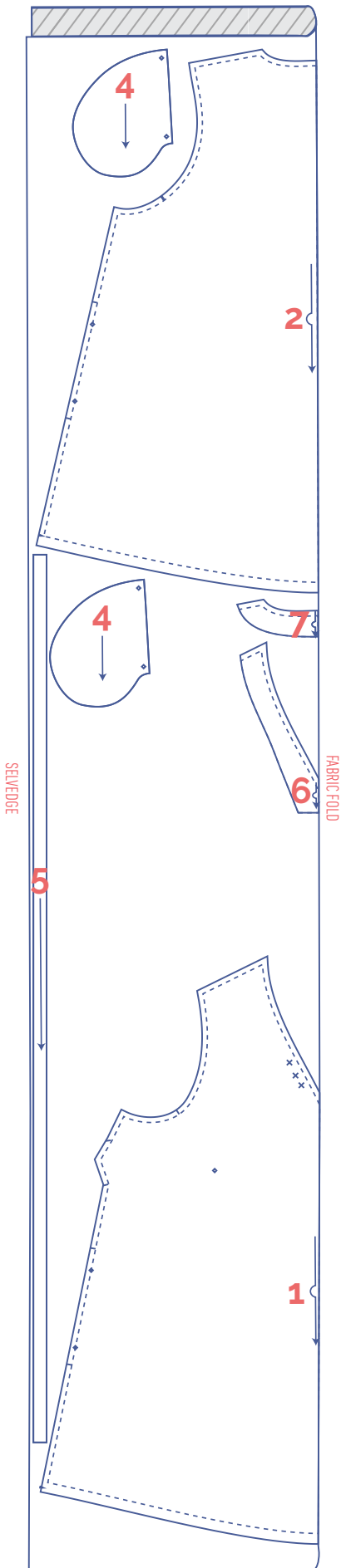

+

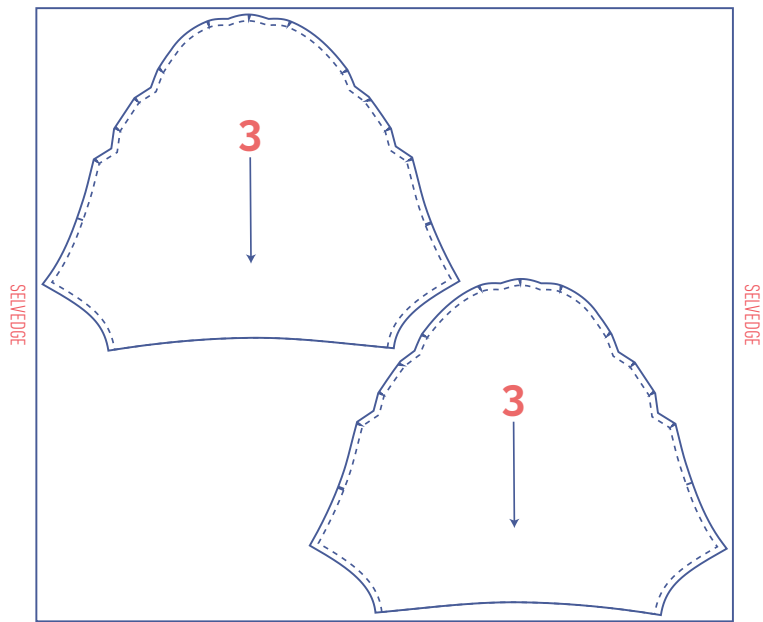

IMPORTANT

Because the fabric is single layer, you'll need to cut mirror images of pattern piece 3 so you have a right sleeve and left sleeve.

IMPORTANT

You only need pattern piece 5 once.

fabric layout – solid fabrics fabric width 55"

0 - 10

12 - 28

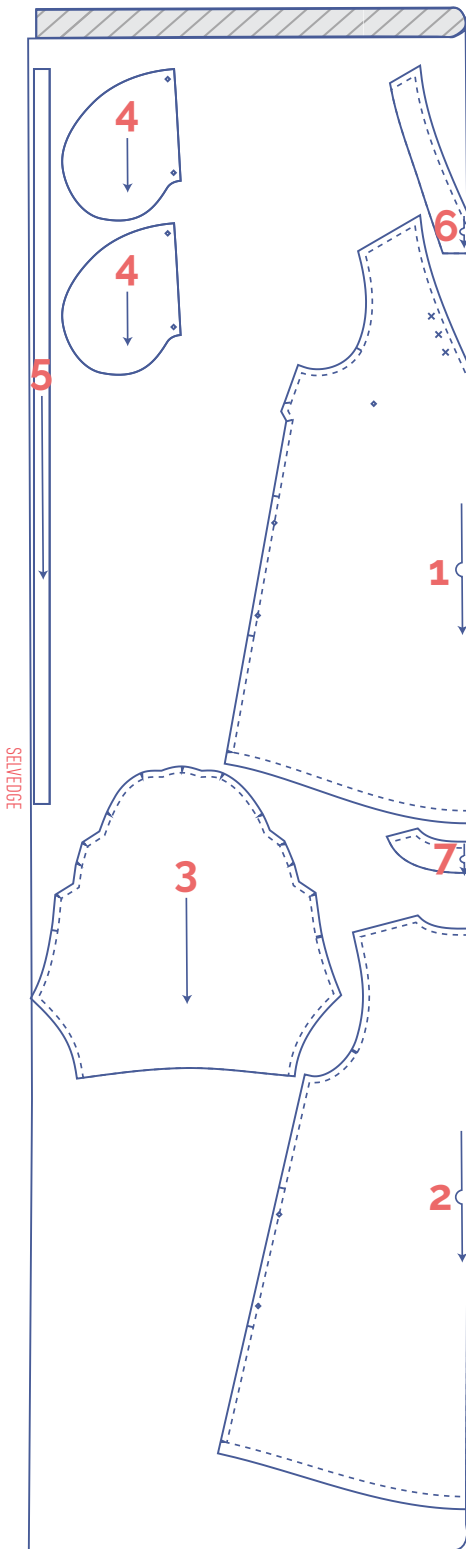

IMPORTANT



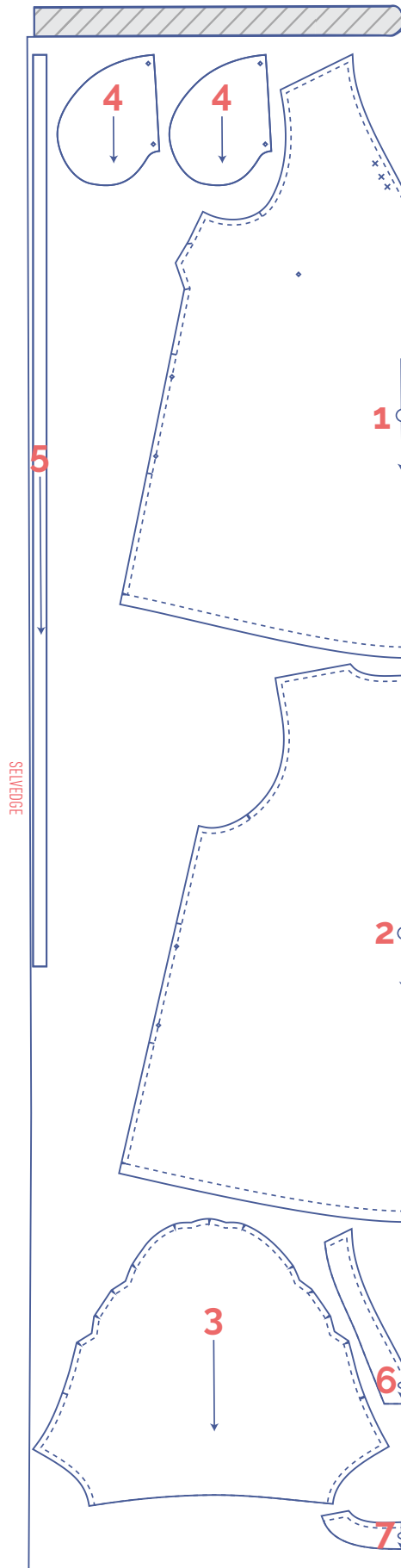

You only need pattern piece 5 once.



IMPORTANT

You only need pattern piece 5 once.

marking pattern pieces

	Notch the pattern paper and fabric at the following points
	single notch
	double notch
V	V notch
	Mark the following points with marking thread
	centre point
	snap/button

sewing instructions



The method used to finish the seams depends on the fabric used. The pieces are always sewn together with the right sides of the fabric facing, unless stated otherwise.



F	front
B	back
CF	centre front
CB	centre back
	right side
	wrong side
	iron-on interfacing

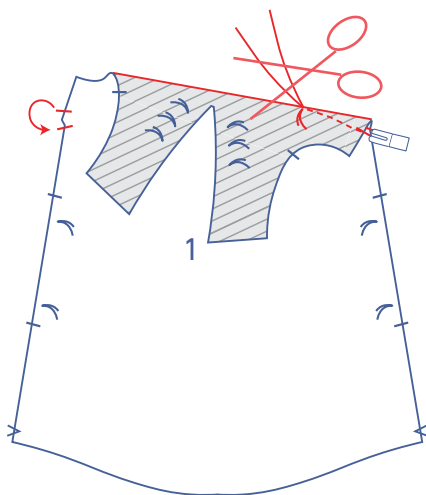
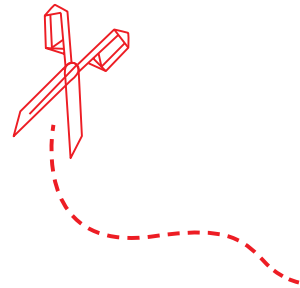

1

Fold the front (1) right sides together at the side seam so the notches match. Sew the bust dart in a slightly curved line towards the marking thread. Sew up to and just past the marking thread, so that you've sewn past the fabric. Snip the threads and tie a knot.

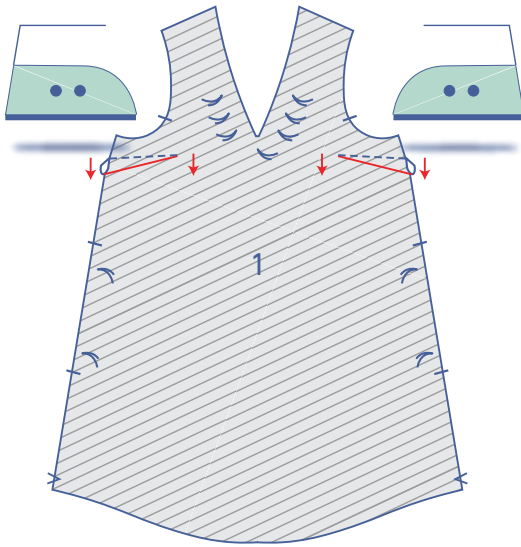

Turn the front over so that the wrong side is facing up. Press the dart down.

2

Pin and sew the shoulder seams of the front and back (2).

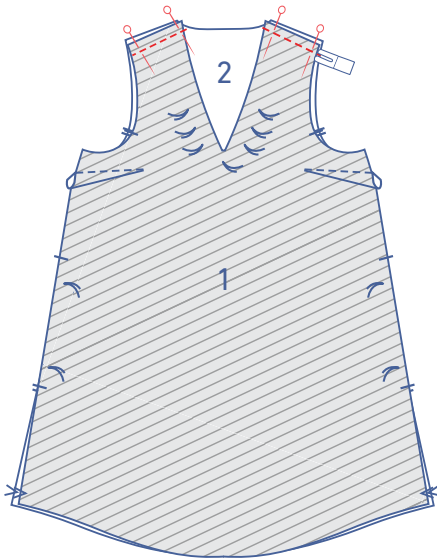

Finish the raw edges with overlock stitching. Press the seam allowance towards the front.

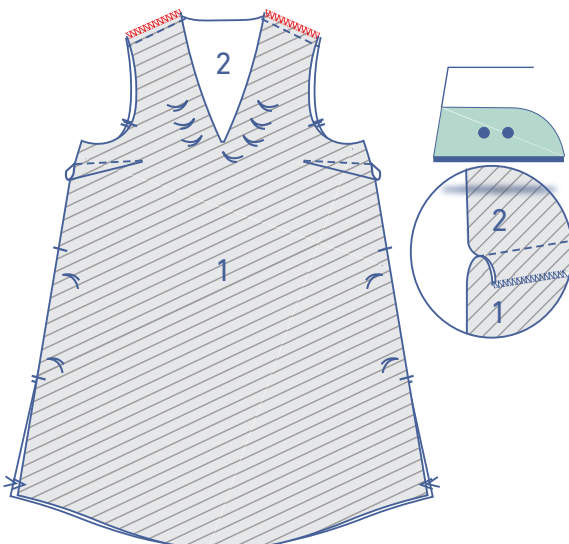

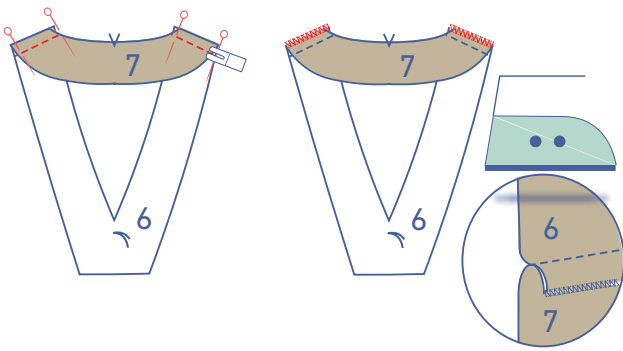

3

Pin and sew the shoulder seams of the facing front (6) and facing back (7). Finish the raw edges with overlock stitching. Press the seam allowance towards the back.

Finish the outer edge of the facing with overlock stitching.

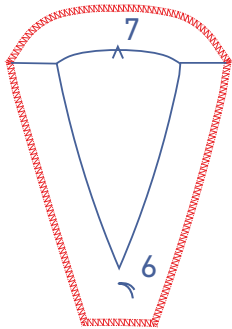

Pin and sew the facing neckline to the neckline of the front and back.

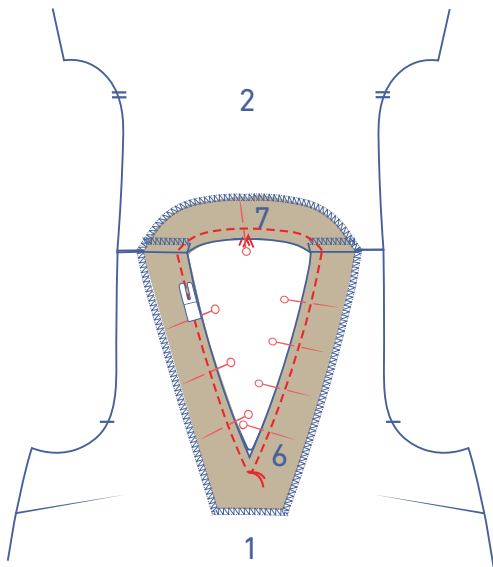

Snip into the seam allowance at the apex of the V until just before the marking thread. Notch the seam allowance at the back so that the facing lies flat when turned out.

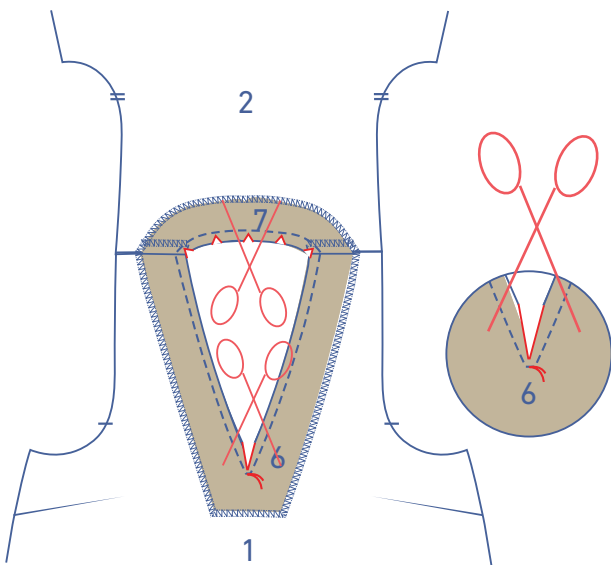

Fold the facing over and sew right next to the seam through all the layers (= facing + underlying seam allowance).

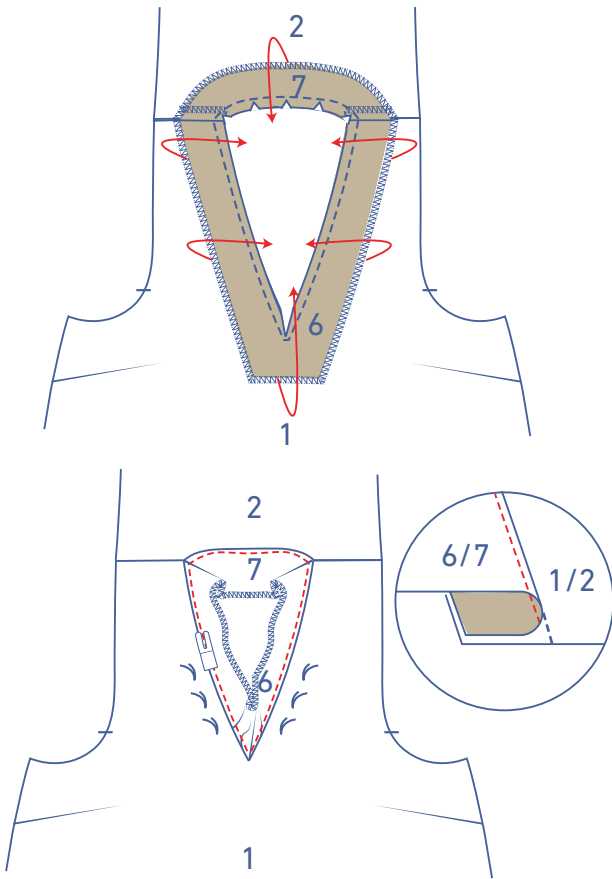

Press the facing neatly towards the wrong side.

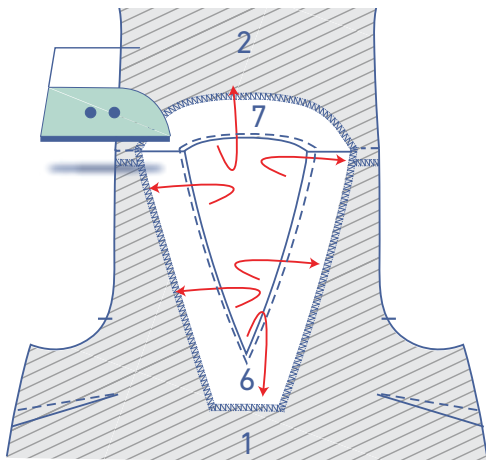

Pin into place, following the edge of the facing. Topstitch along the right side of the fabric, anchoring all layers.

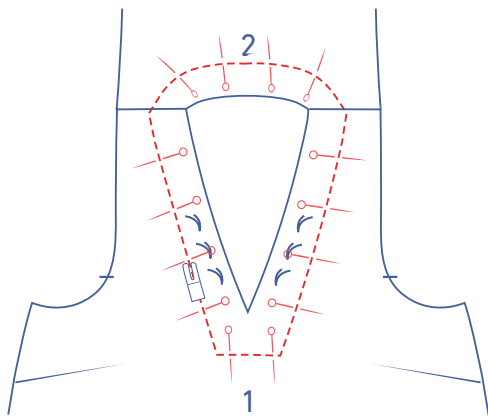

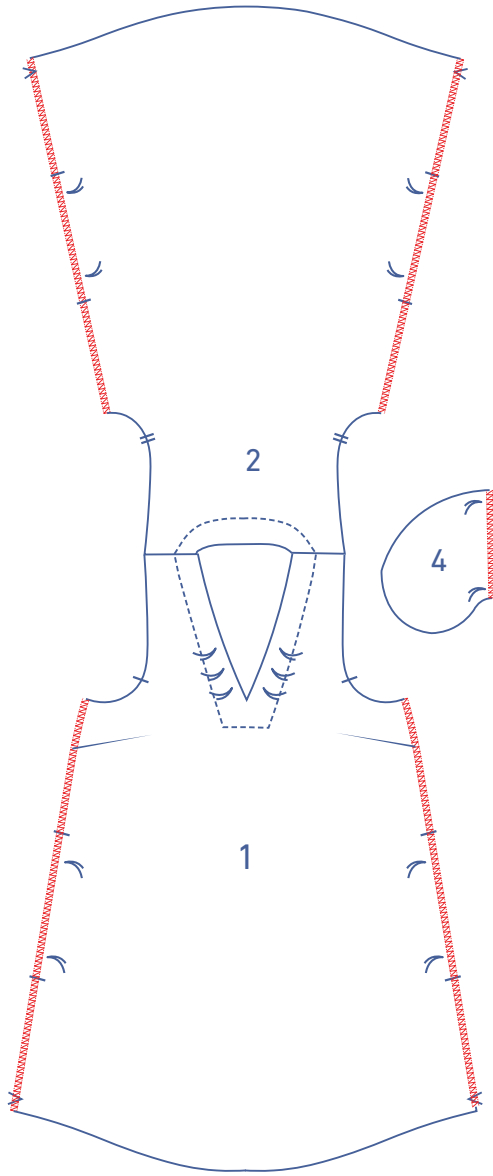

4

Finish the raw edges of the front and back and the straight ends of the pocket (4) with overlock stitching.

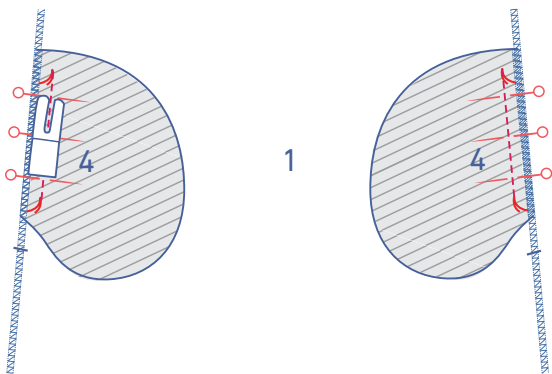

Pin the straight ends of 2 of the 4 pocket pieces to the front, matching the marking threads. Sew into place between the marking threads.

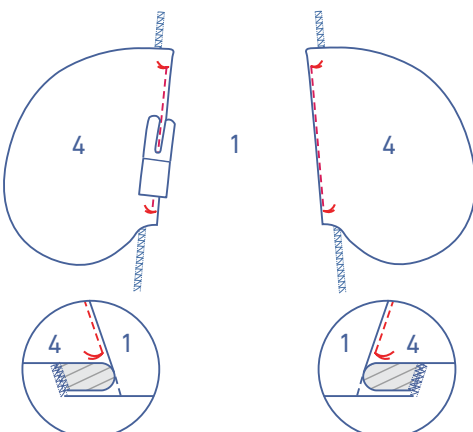

Fold the pocket and seam allowance over and sew the pocket to the seam allowance underneath (= understitch).

Pin the straight ends of the two remaining pocket pieces to the back, matching the marking threads. Sew into place between the marking threads. Fold the pocket pieces over but do not understitch.

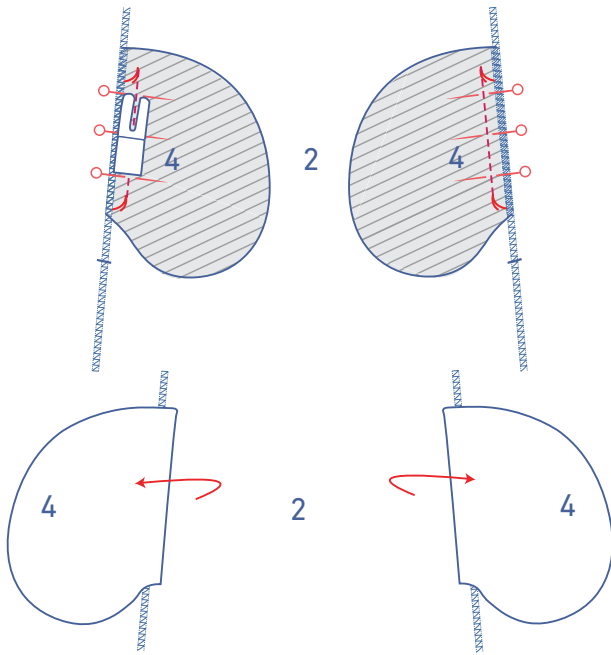

Pin and sew the side seams from the underarm up to the marking threads that mark the top of the pocket opening. Now, sew from the next marking thread to the hem. Press the seam allowance open.

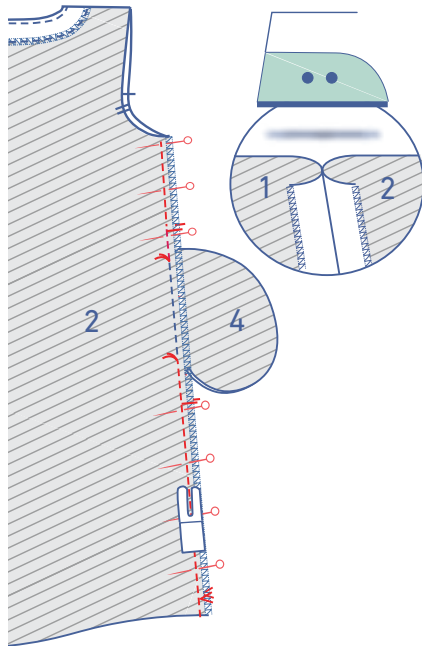

Pin and sew the contours of the pocket pieces together at 5/8".

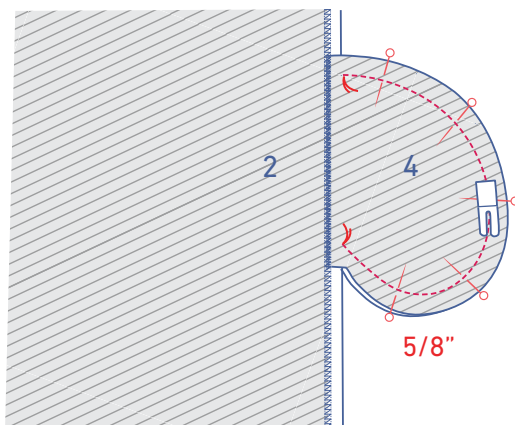

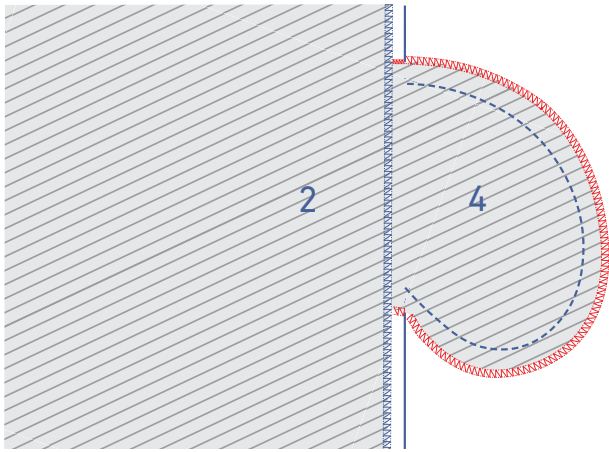

Finish the raw edges with overlock stitching.

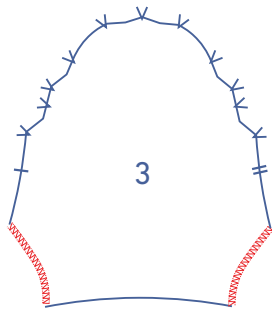

5

Finish the edges of the sleeve (3) with overlock stitching where indicated.

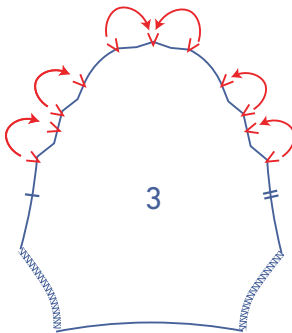

Pin the V notches at the top of the sleeve together in the direction indicated, with the wrong sides of the fabric facing each other.

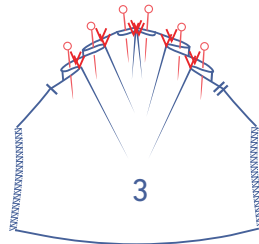

Tack the pleats temporarily into place right next to the edge.

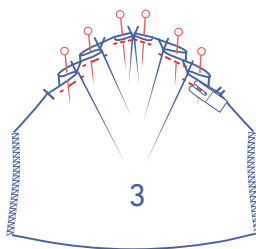

Fold the sleeve in half with the right sides of the fabric facing and sew the underarm seam. Press the seam allowance open.

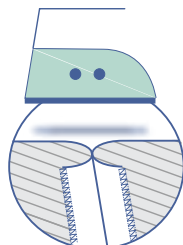
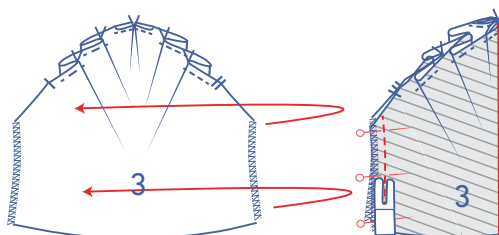

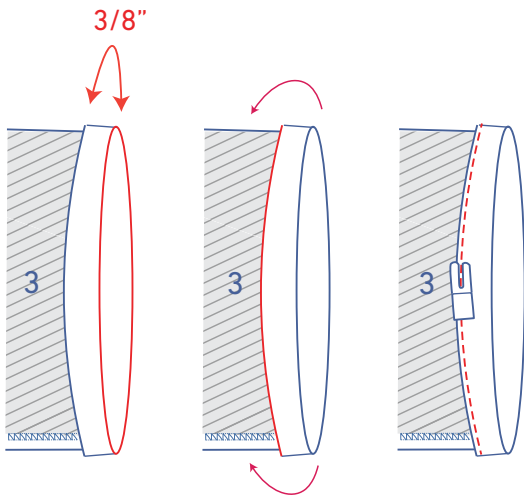

Turn $\frac{3}{8}$ " of the sleeve hem towards the wrong side and then turn up again. Sew into place right next to the edge.

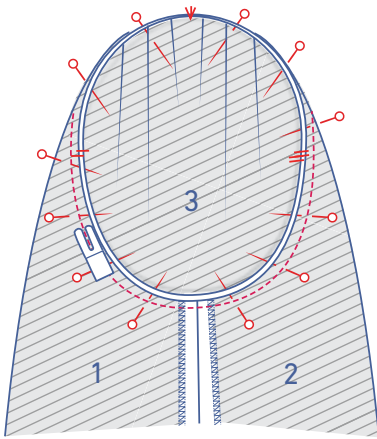

Pin the top of the sleeve to the armhole with the notches matching. The single notch marks the front, while the double notch marks the back. The V notches in the top please should line up evenly with the shoulder seam. Sew into place.

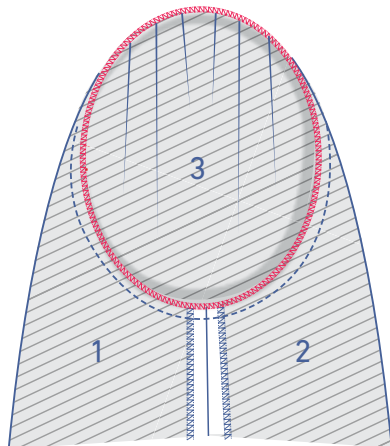

Finish the raw edges with overlock stitching.

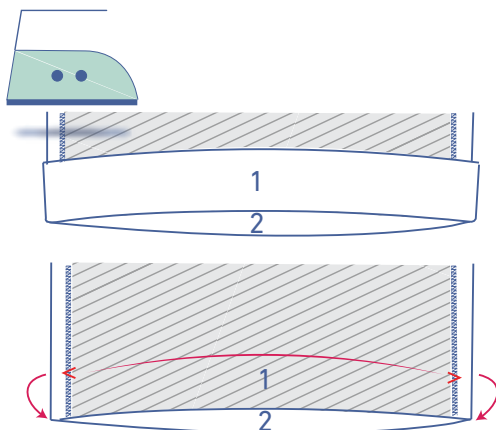

6

Press the hem allowance of the dress over at the V notches and open back out.

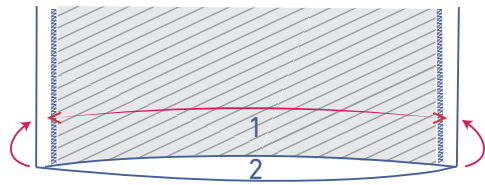

Fold the raw edge to the pressed fold line, and then turn up again.

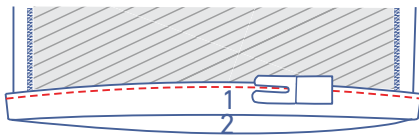
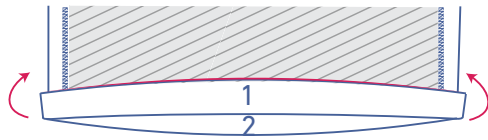

Sew the hem allowance into place right next to the edge.

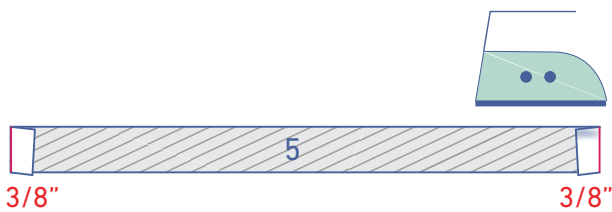

7

Press both short ends of the tie (5) $\frac{3}{8}$ " towards the wrong side.



Fold the tie in half with the long ends together and the wrong sides of the fabric facing each other.



Open back out.

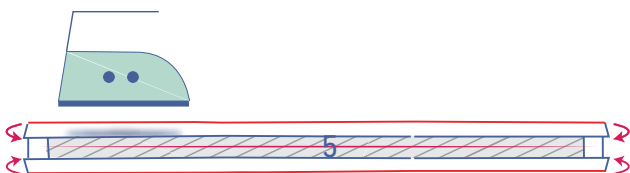

Press the raw edges in to meet the fold line in the middle.



Now, fold back in half along the pressed centre line.

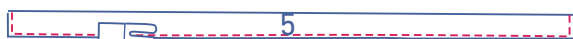

Sew all the way around, right next to the edge.



8

Attach the eyelets where indicated.

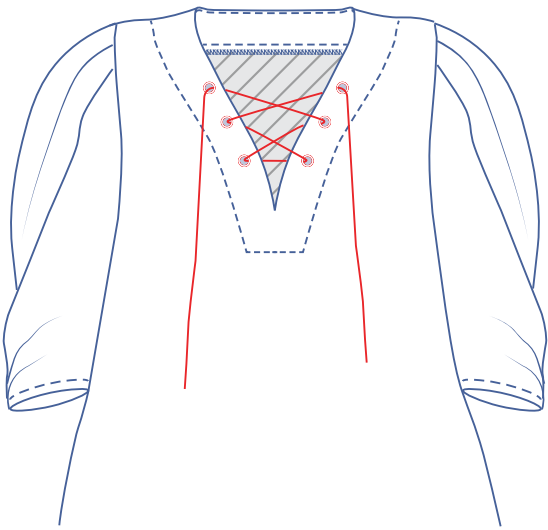

Lace the cord/tie through the eyelets.