

Rachel by Fibre ⚡ood



Rachel by Fibre ood



0 - 28

Bermuda season is here! And Rachel is a simple yet stylish addition to your summer wardrobe. It's fun to make and great to wear. So, feel free to pick a few different fabrics with 'one is never enough' as your motto. Rachel has double pleats at the front and tailored darts at the back. There are handy side seam pockets and turned up hems above the knee.

Zip, button – done and dandy. Time to bare those legs!

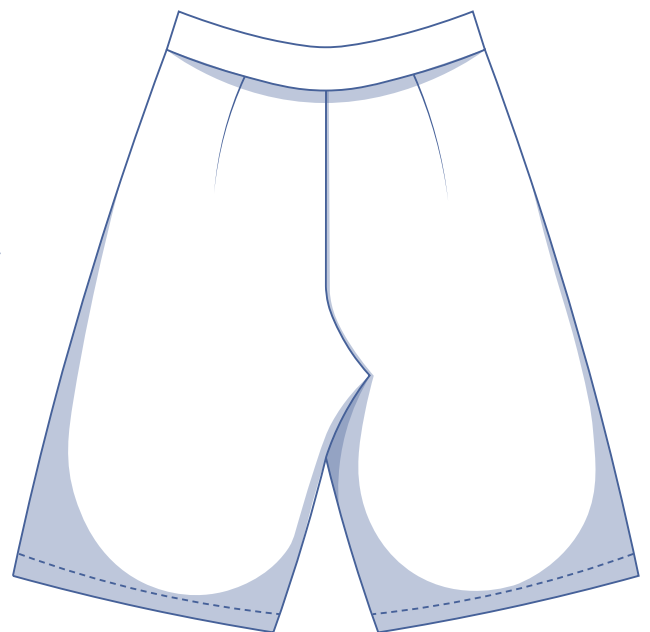
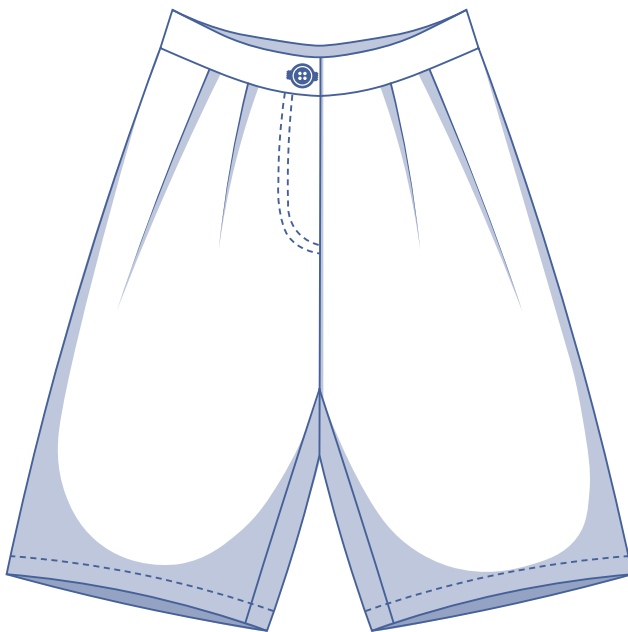

size chart (in inches)

size	0	2	4	6	8	10	12	14	16	18	20	22	24	26	28
body height	5' 25"	5' 38"	5' 45"	5' 48"	5' 51"	5' 54"	5' 58"	5' 61"	5' 64"	5' 64"	5' 64"	5' 64"	5' 64"	5' 64"	5' 64"
W (waist)	26	26.8	27.6	29.1	30.7	32.3	33.1	34.6	37.2	39.8	42.3	44.9	47.4	50	52.6
H (hips)	33.9	35.4	37	38.2	39.4	40.6	41.7	42.9	45.3	47.2	49.2	51.2	53.1	55.1	57.1

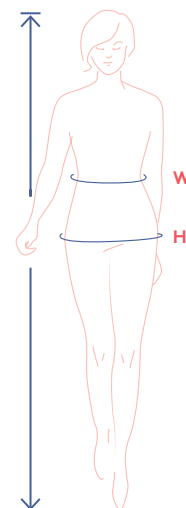

To choose your size, start with your **waistline measurement**. Pick the size that's the best match for your waistline. Next, see which size is closest to your hip measurement. Is your hip measurement wider than what's listed in the size chart? If so, check the hip measurements in the chart below to see if there's enough room or whether the pattern size needs to be altered. It's easy to do. When tracing the pattern, simply trace from the line of one size to the line of the other.

pattern measurements (in inches)

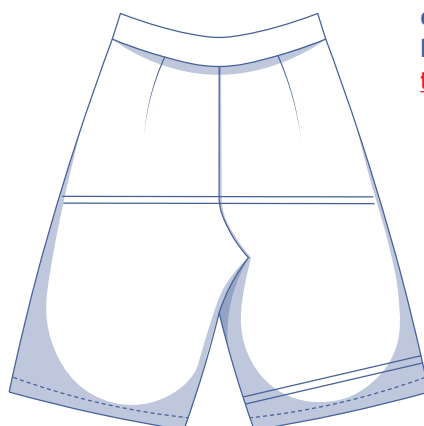
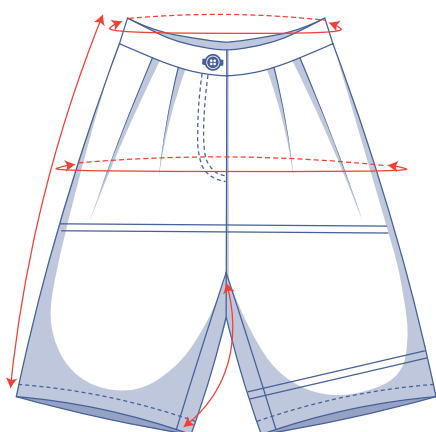

== shorten or lengthen the pattern here

This chart's measurements are the pattern measurements based on the fabric type and serve as a reference. Ease has been added to the width measurements (on top of the exact body measurements) for a more comfortable fit. Rachel is designed to be **fitted at the waist and relaxed at the hips**.

size	0	2	4	6	8	10	12	14	16	18	20	22	24	26	28
side length*	24.6	24.8	25	25.2	25.4	25.5	25.7	26	26.1	26.3	26.5	26.7	27	27.1	27.3
inseam length	12.2	12.2	12.3	12.3	12.3	12.3	12.3	12.3	12.4	12	12	13	12.5	12.5	12.6
waistline	26	26.8	27.6	29.2	30.8	32.3	33.1	34.7	37.3	39.8	42.4	44.9	47.5	50	52.6
hips**	37.8	39.3	40.9	42.1	43.3	44.5	46	46.9	49.3	51.2	53.2	55.2	57.1	59.1	61.1

* Including the waistband.

** Including the pleat allowances.

Compare the stated lengths to the measured or desired lengths. **Shorten** or **lengthen** the rise and/or trouser legs by cutting the pattern pieces at the indicated double lines. Then either increase the distance between the cut pieces by the desired amount (to lengthen) or overlap the pieces (to shorten). Make sure that the CF and CB lines and the side seams are always straight.



IMPORTANT

Adjust the amount of fabric to be used based on these alterations.

notions



- Thread
- Iron-on interfacing: max. 53"
- Button or snap fastener (Ø 1 1/16"): 1
- Closed end zip: see table
- Fabric: see table

zip		0	2	4	6	8	10	12	14	16	18	20	22	24	26	28
length	yd	6	6	6	6	6	6	6	7	7	7	7	7	7	7	7

fabric use		0	2	4	6	8	10	12	14	16	18	20	22	24	26	28
fabric width 43"	yd	1 ½	1 ½	1 ½	1 ½	2	2	2	2	2	2 ¼	2 ½	2 ½	2 ½	2 ¾	2 ¾
fabric width 55"	yd	1 ½	1 ½	1 ½	1 ½	1 ½	1 ½	1 ½	1 ¾	1 ¾	1 ¾	2	2	2	2	2

The corresponding fabric layout can be found on page 6 of these sewing instructions.

fabric advice



Anything is possible – really! Rachel is easy to make in poplin (stretch or non-stretch) or chambray. Linen, baby wale corduroy, gabardine or even leather(ette) would also be perfect.

Proud to be #Sewista

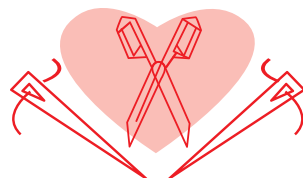

pattern pieces & seam allowances (in inches)

To sew the garment as described in the instructions, draw the illustrated seam allowances around the paper pattern pieces before cutting them out. If you are using a PDF pattern, the pattern can be printed with or without seam allowance. To find out more, watch the [video](#).

1. front: 2x
2. back: 2x
3. waistband: 1x
4. pocket: 4x
5. fly: 1x

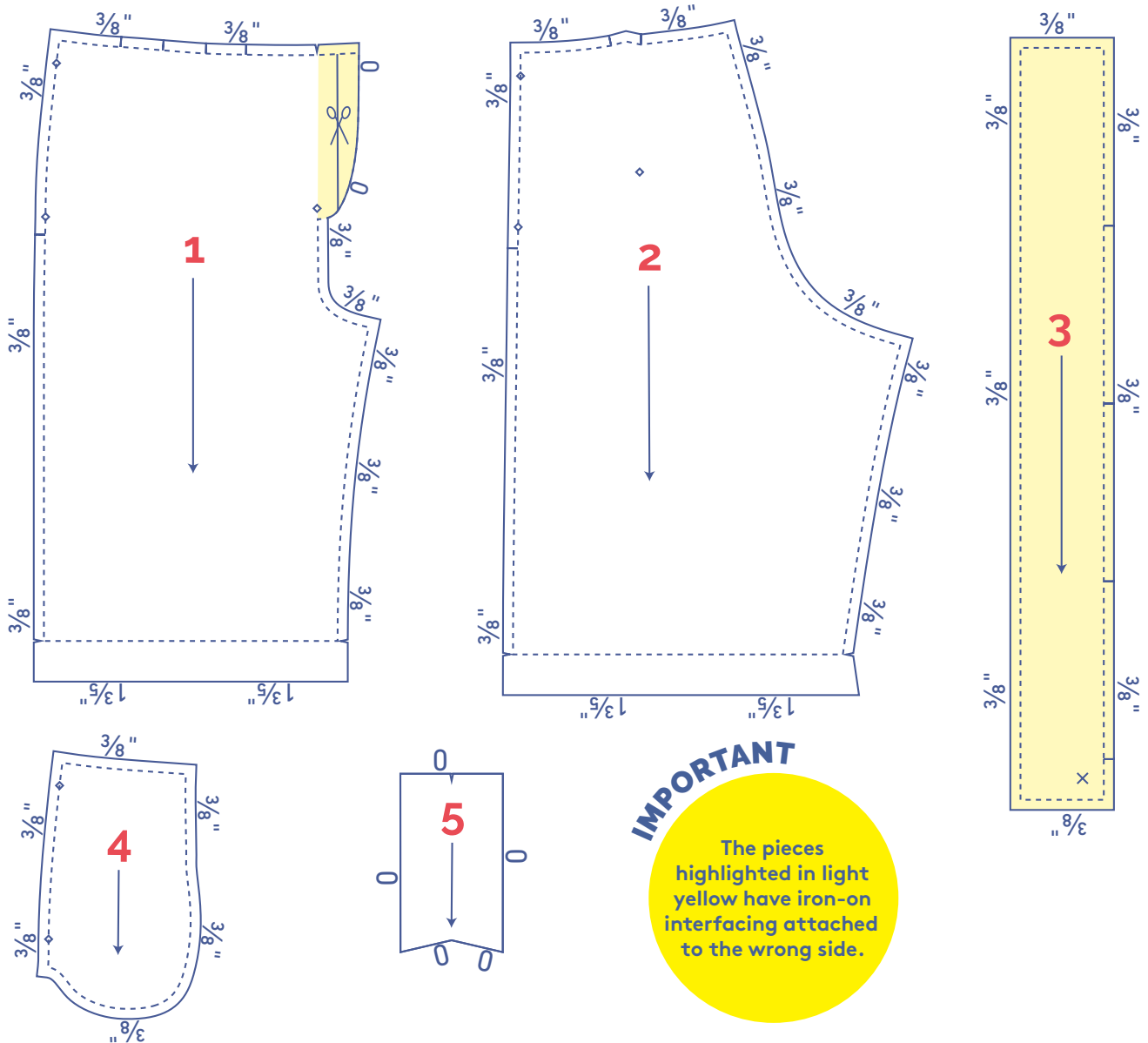

	material type
	fabric
	iron-on interfacing

fabric layout – solid fabrics
fabric width 43"

0 - 6

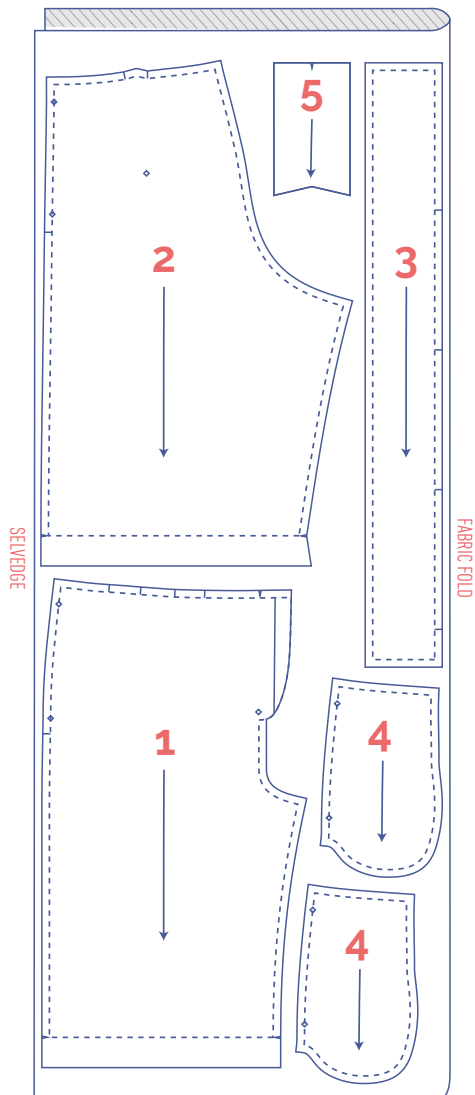

IMPORTANT

You only need pattern pieces 3 and 5 once.

8 - 16

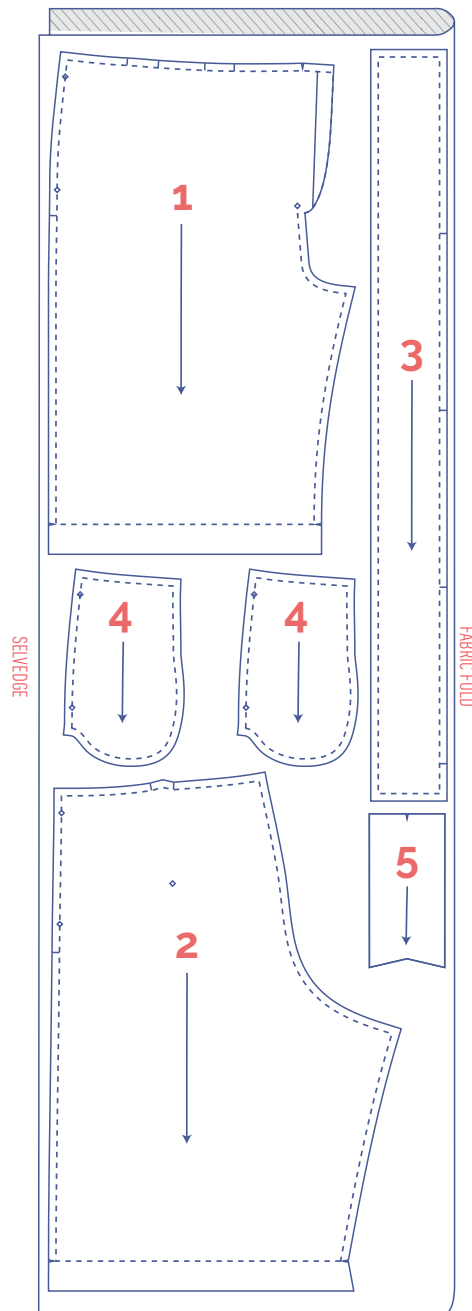

IMPORTANT

You only need pattern pieces 3 and 5 once.

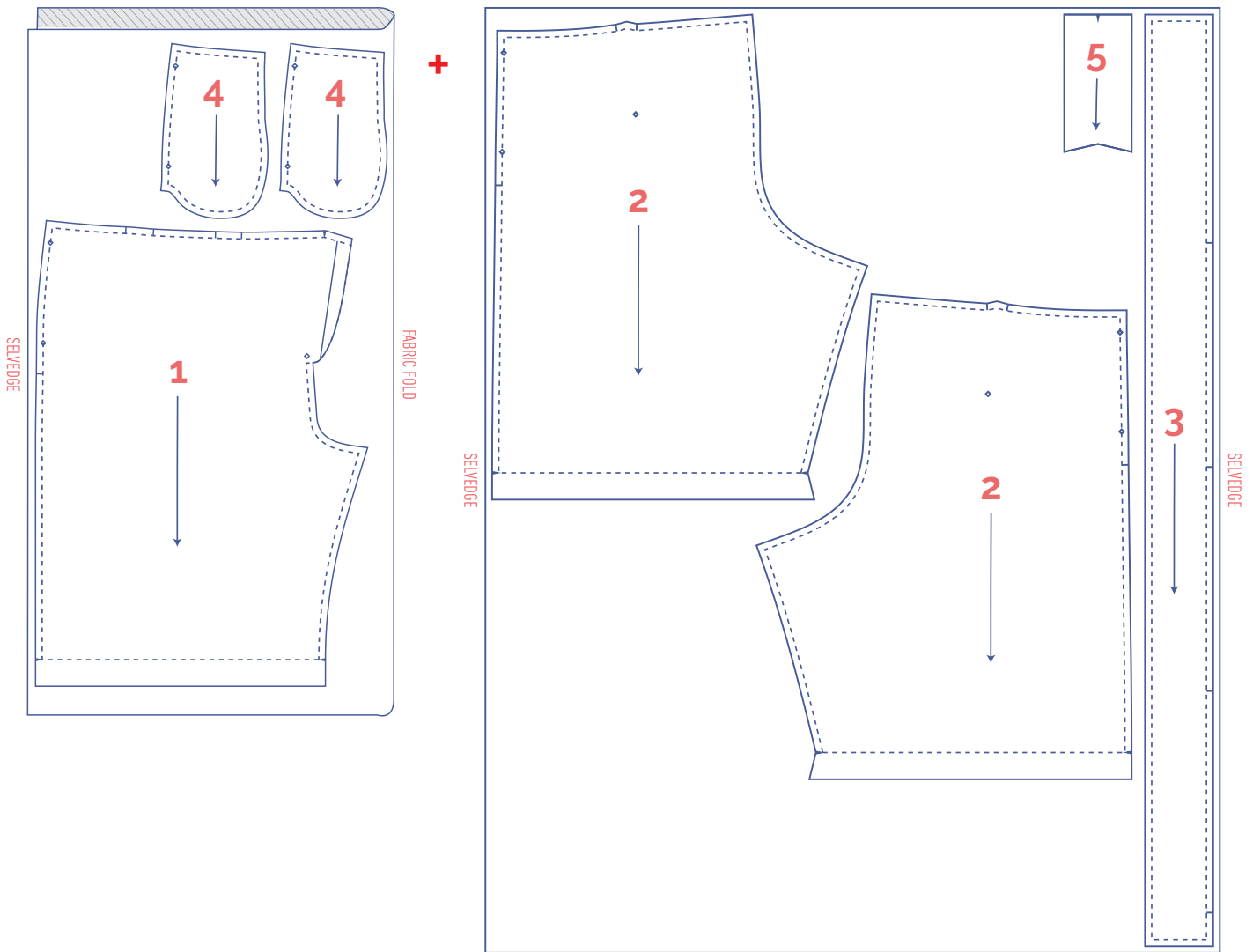

marking pattern pieces



Notch the pattern paper and fabric at the following points

| single notch

∨ V notch / fabric fold



Mark the following points with marking thread

◇ centre point

✕ snap/button

fabric layout – solid fabrics
fabric width 55" cm

0 - 18

20 - 28

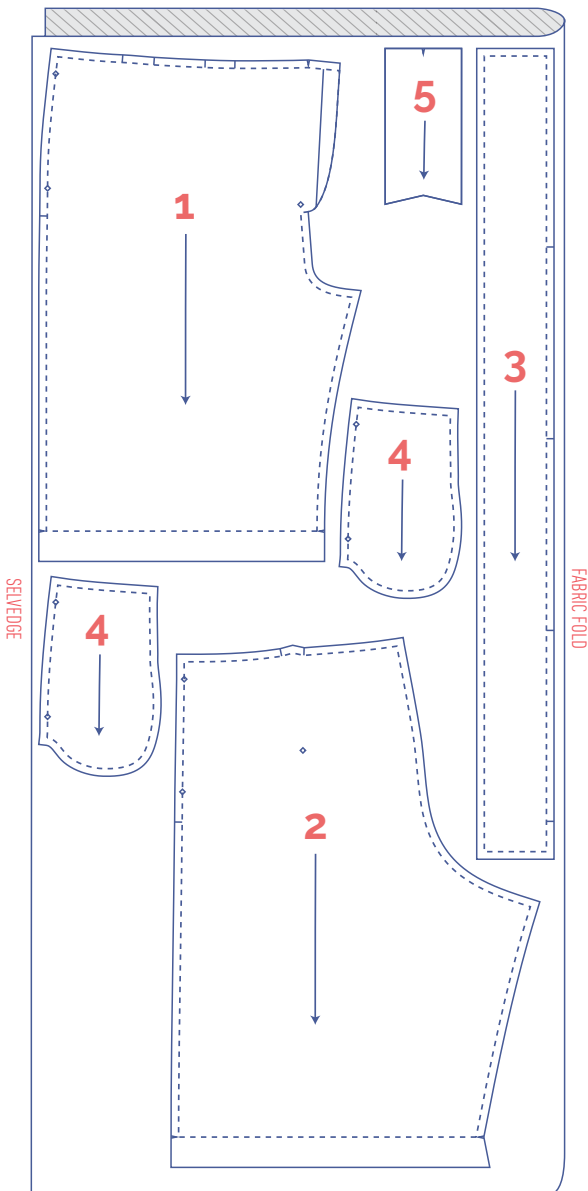

IMPORTANT



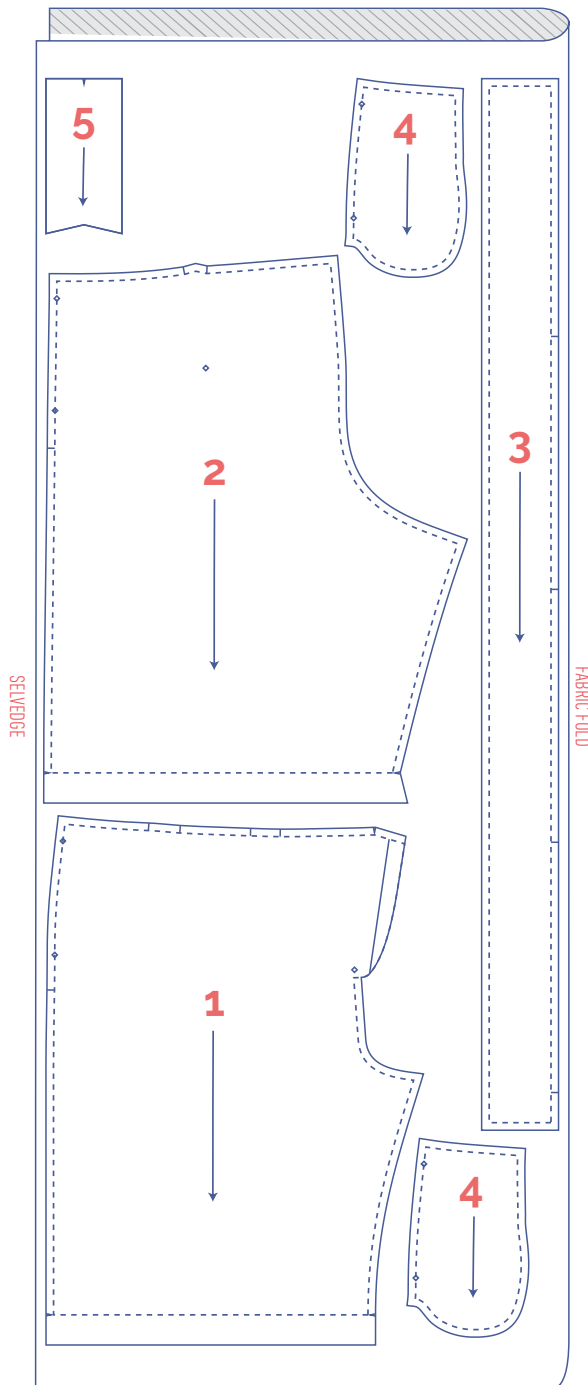

You only need pattern pieces 3 and 5 once.



IMPORTANT

You only need pattern pieces 3 and 5 once.

marking pattern pieces





 <p>Notch the pattern paper and fabric at the following points</p>	 <p>Mark the following points with marking thread</p>
<p> single notch</p>	 <p>centre point</p>
<p>V V notch/fabric fold</p>	 <p>snap/button</p>

sewing instructions



The method used to finish the seams depends on the fabric used. The pieces are always sewn together with the right sides of the fabric facing, unless stated otherwise.



F	front
B	back
RF	right front 
LF	left front 
CF	centre front
CB	centre back
	right side
	wrong side
	iron-on interfacing

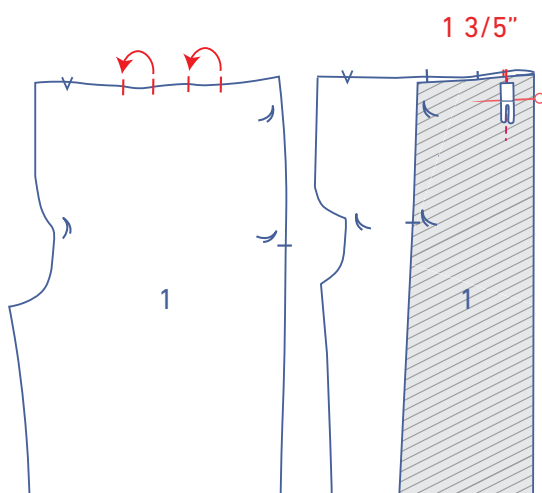
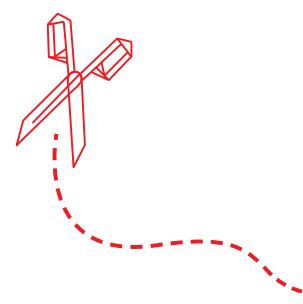

1

Match the notches in the top of the front pieces (1) right sides together in the direction indicated to form pleats. Vertically sew the pleats into place (approx. 1 3/5").

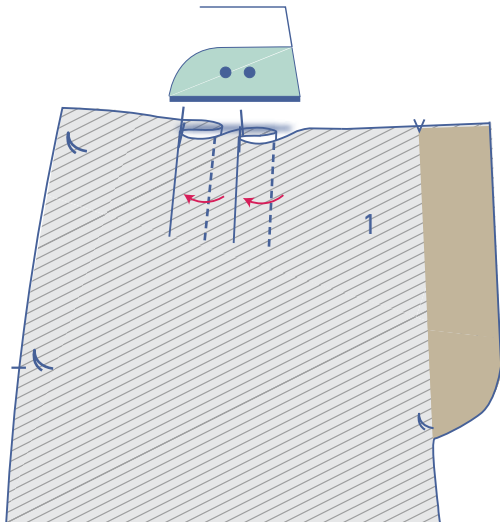

With the wrong side facing up. press the pleats towards the side seam.

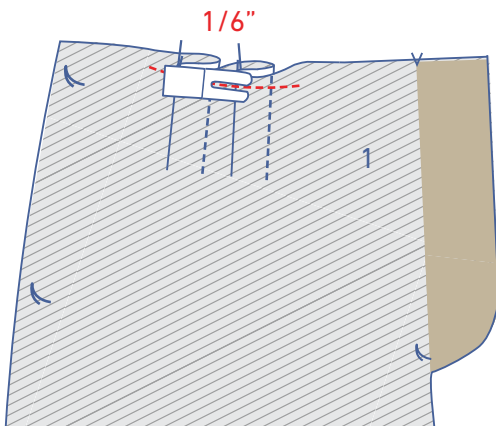

Sew the pleats into place at 1/6" from the raw edge.

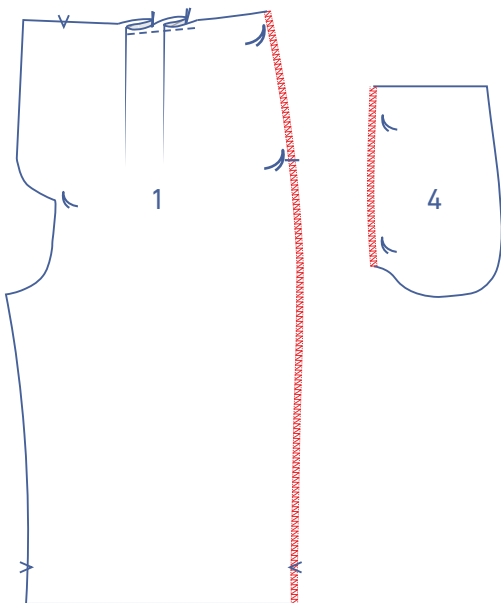

Finish the sides of the front and the indicated pocket end (4) with overlock stitching.

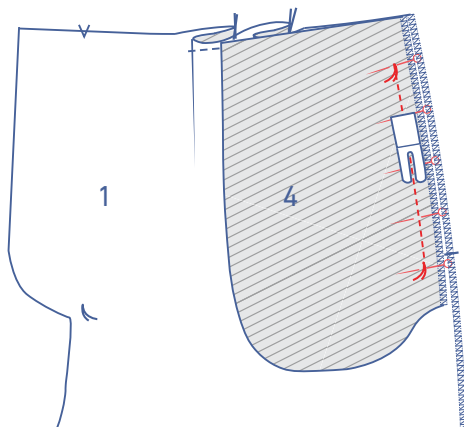

Pin the two pocket pieces to the side seams of the front, matching the marking threads. Sew the pocket pieces into place between the marking threads.

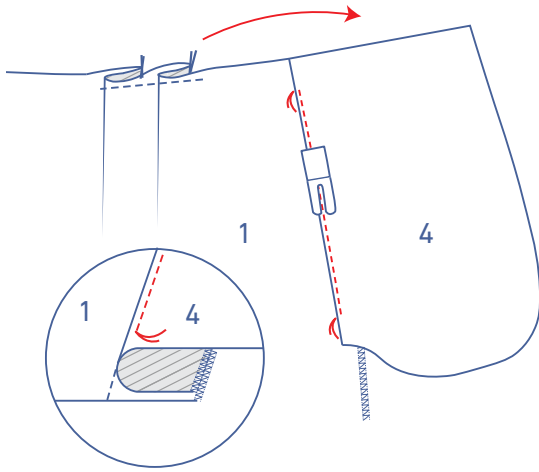

Fold the pocket pieces over and sew the pocket to the seam allowance underneath between the marking threads and right next to the seam.

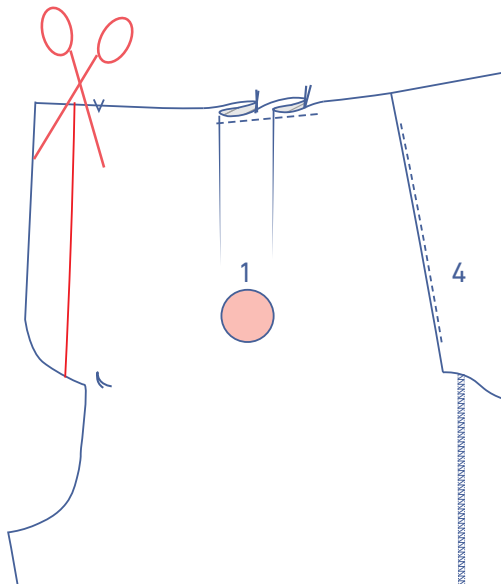

2

Cut a piece from the LF along the indicated line.

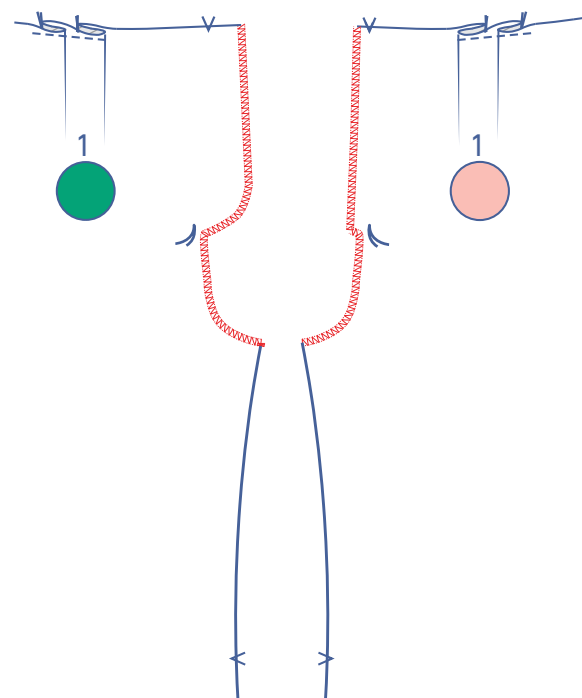

Finish the raw edges with overlock stitching where indicated.

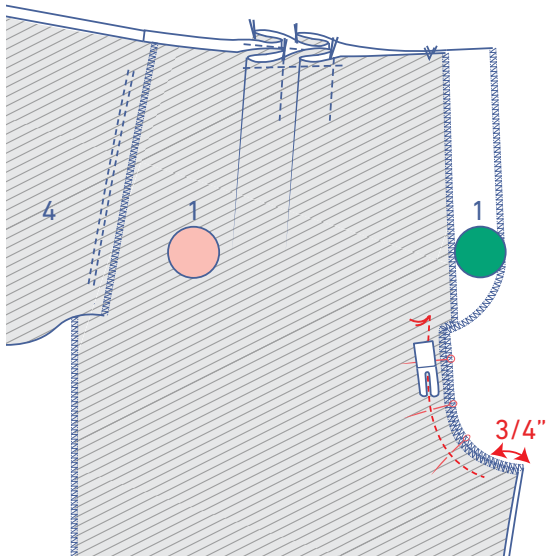

Pin the V notches and marking threads of the RF and LF together. Please note: the RF fly extends past the LF. Sew the CF seam from the marking thread to approx. $\frac{3}{4}$ " before the edge.

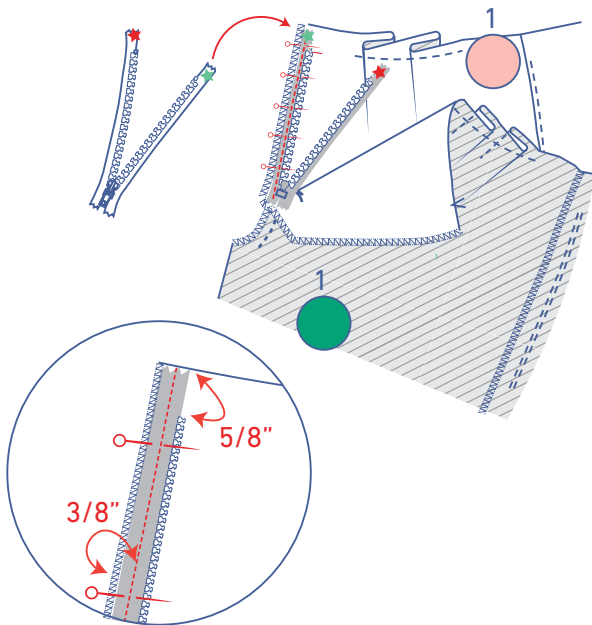

First, place the zip in front of you with the right side facing up. Open the zip and flip the green star zip tape over to the right and onto the LF. The edge of the zip tape should be next to the overlock stitching, and the zip teeth should be $\frac{5}{8}$ " under the top edge. Pin and sew into place at $\frac{3}{8}$ " from the CF seam (= the middle of the zip tape) with the zipper foot.

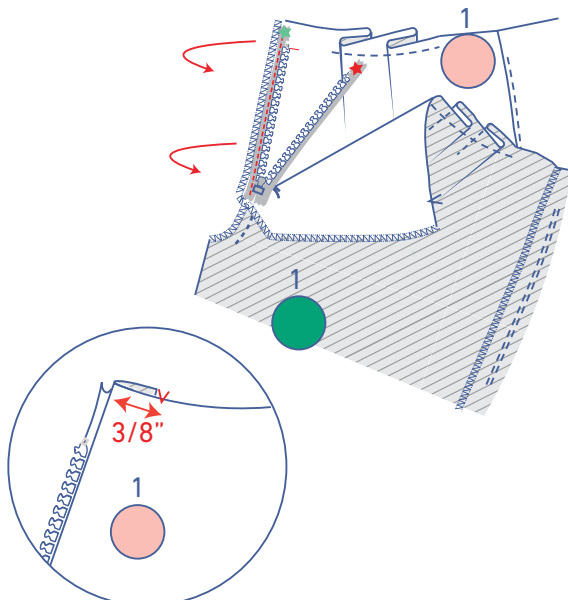

Then fold the zip tape over towards the wrong side.

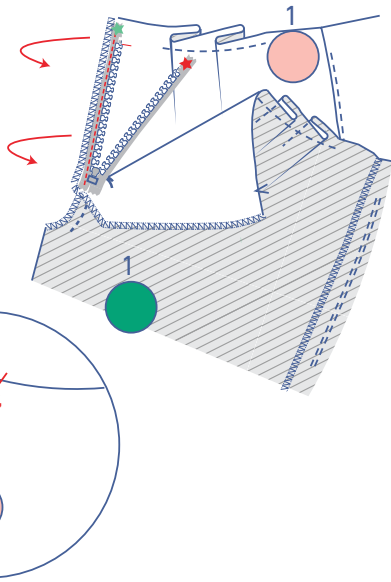

Close the zip and align front pieces with the right sides together, matching V notches in the CF. Press both front pieces neatly flat.

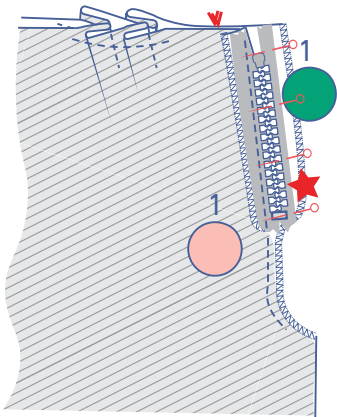

Pin the red star zip tape to the RF fly.

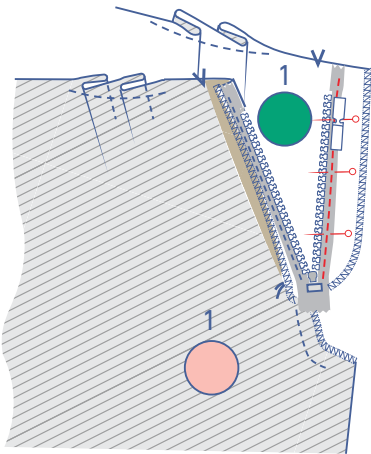

Open the zip and stitch the zip tape into place with the zipper foot.

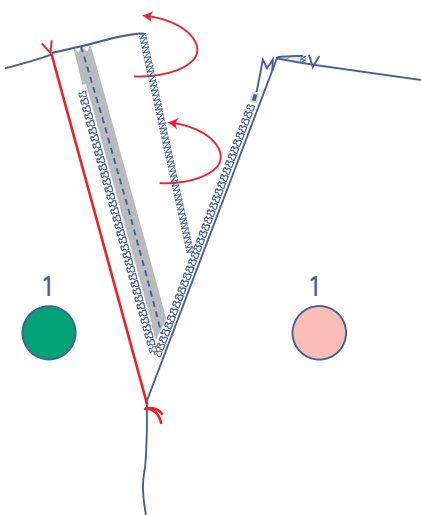

Fold the RF fly towards the wrong side at the V notch.

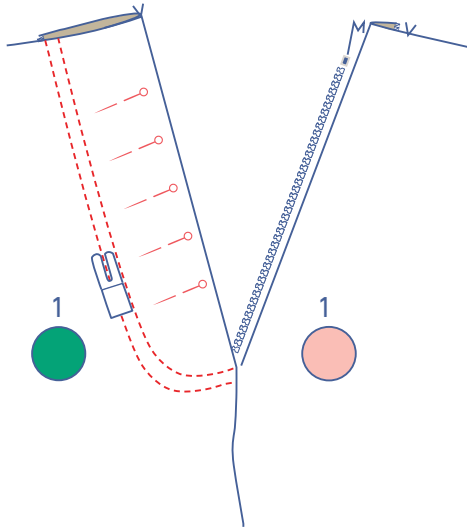

Pin into place and topstitch two parallel lines along the right side of the fabric. following the contour of the fly and anchoring all layers.

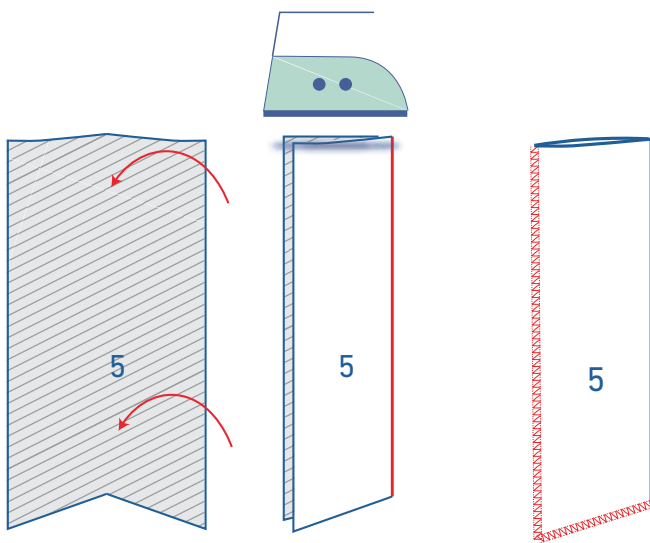

3

Press the fly (5) in half with the long ends touching and the wrong sides facing each other.

Finish the raw edges with overlock stitching where indicated.

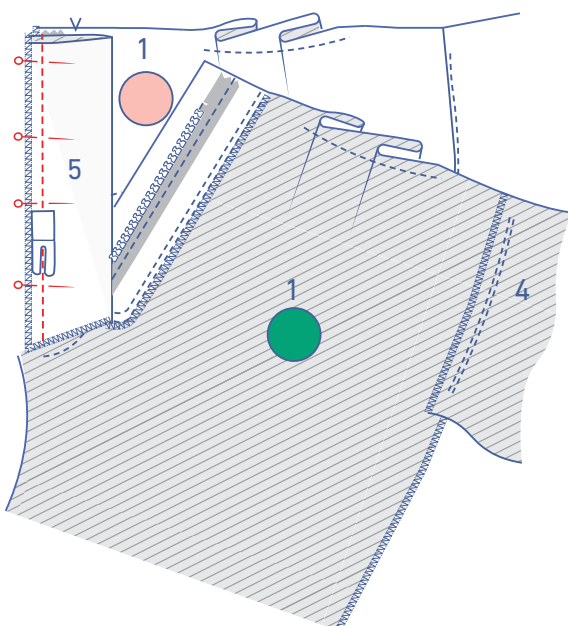

Pin the fly to the seam allowance of the LF and the zip and sew into place.

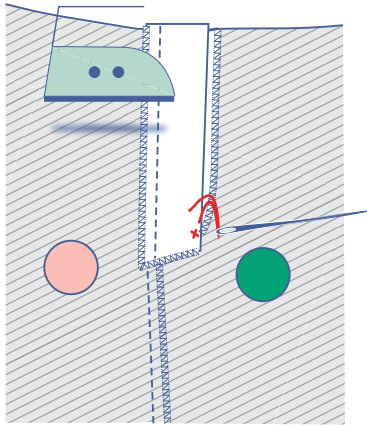

Press the fly over and close the zip. Hand stitch the RF fly and LF fly pieces together with a stitch or two at the bottom.

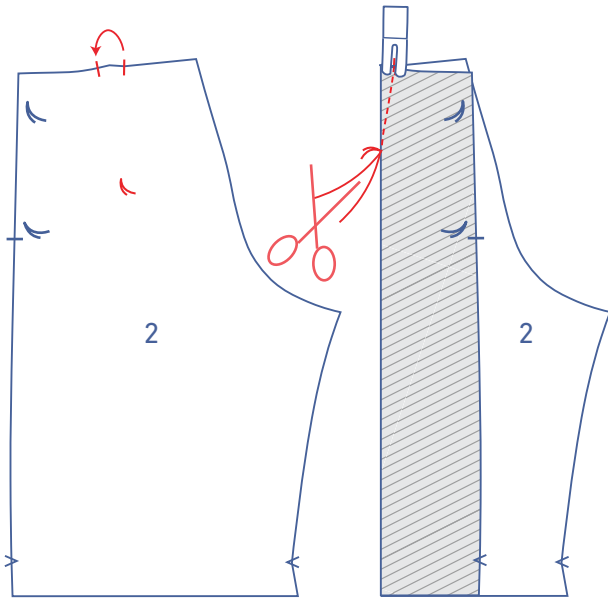

4

Match the notches in the waist seam of the back (2) with the right sides of the fabric facing each other. Sew the dart in a slightly curved line towards the marking thread. Sew up to and just past the marking thread, so that you've sewn past the fabric. Snip the threads and tie a knot.

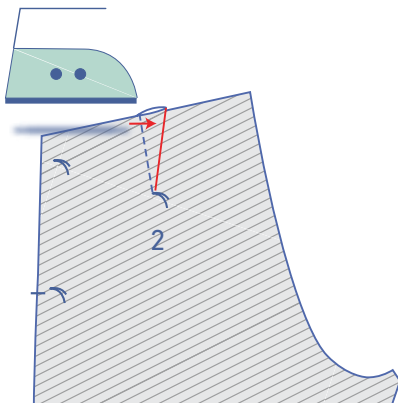

Press the dart allowance towards the CB.

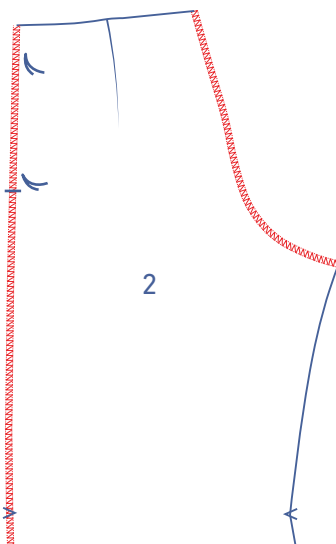

Finish the CB seam and sides with overlock stitching.

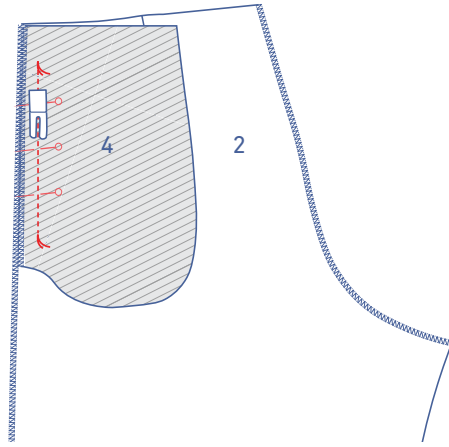

Take the two remaining pocket pieces and pin them to the side seams of the back, matching the marking threads. Sew the pocket pieces into place between the marking threads.

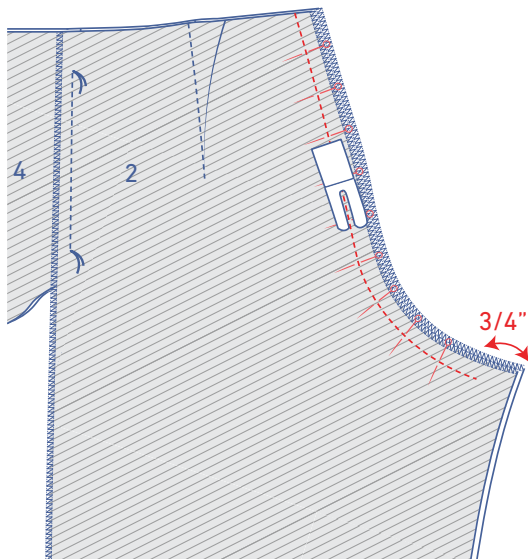

Pin and sew both back pieces (2) together at the CB seam. Stop approx. $\frac{3}{4}$ " from the raw edge.

5

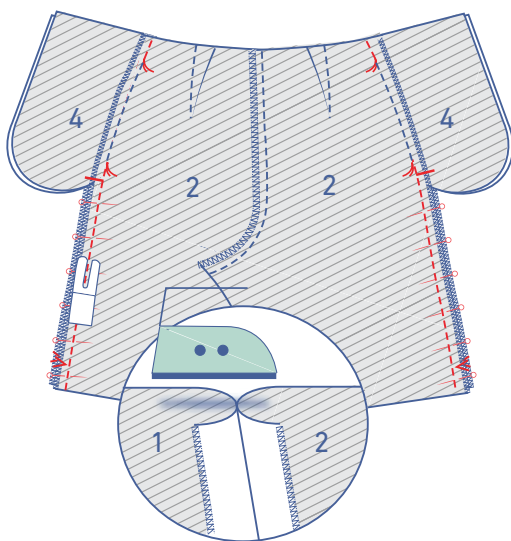

Pin the side seams of the front and back together. Sew from the waist to the marking threads that mark the top of the pocket opening, and then sew from the next set of marking threads to the hem.

Press the seam allowances open.

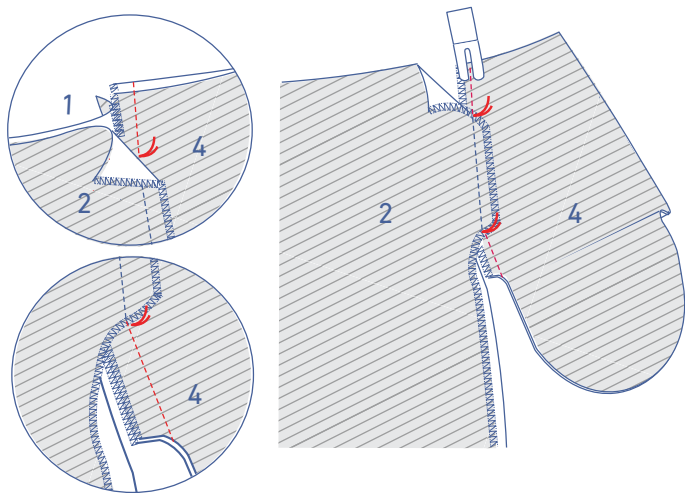

Fold the side seam allowances of the shorts out of the way. Pin and sew the small pieces of pocket side seam above and underneath the pocket opening marking threads as well.

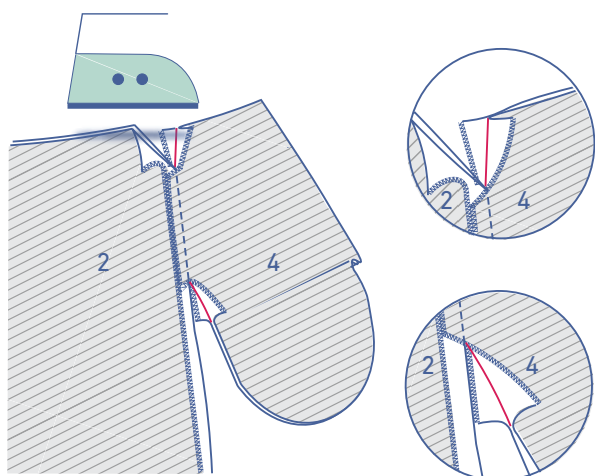

Press the seam allowances open.

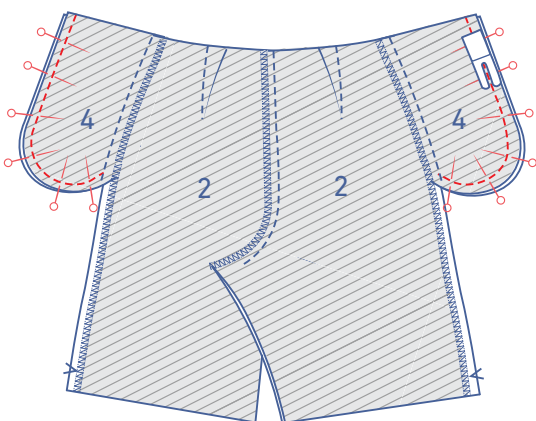

Pin and sew the contours of the pocket pieces together.

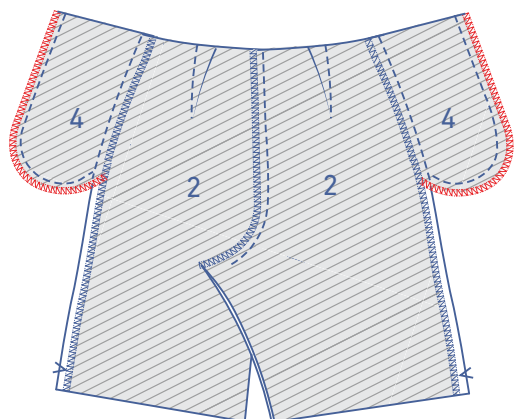

Finish the raw edges with overlock stitching.

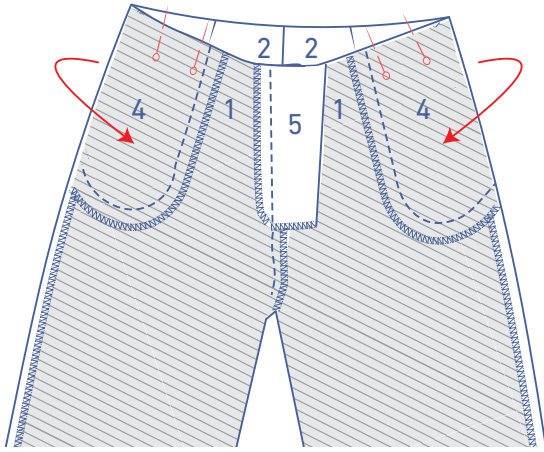

Fold the pocket pieces towards the wrong side of the front so the top of the pocket and the front evenly line up. Pin into place.

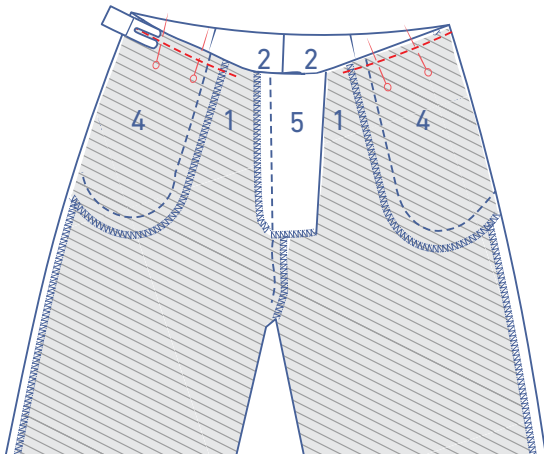

Sew the top of the pocket to the front at presser foot width from the raw edge.

6

Pin and sew the inseams together.

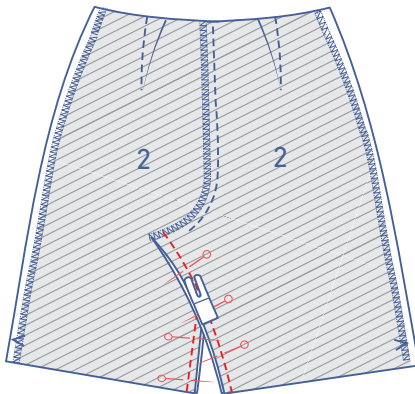

Finish the raw edges with overlock stitching.

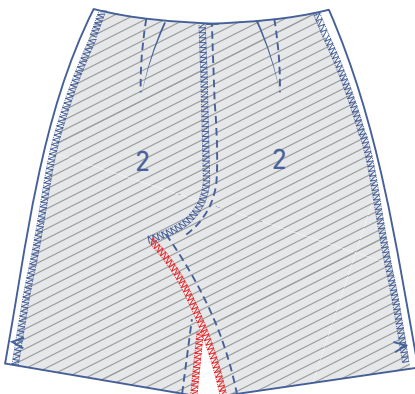

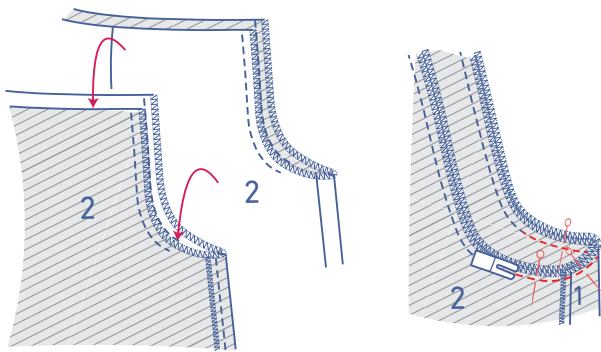

Slide one trouser leg into the other with the right sides of the fabric touching. Pin and sew the remaining crotch seam.

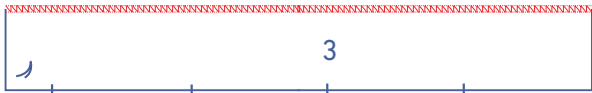

7

Finish the unnotched long end of the waistband (3) with overlock stitching where indicated.

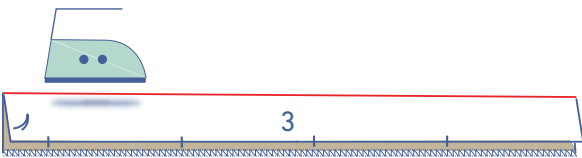

Press the waistband in half lengthwise, with the long ends together and the wrong sides of the fabric touching.

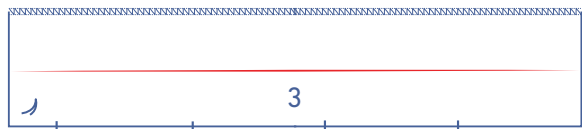

Then open back out.

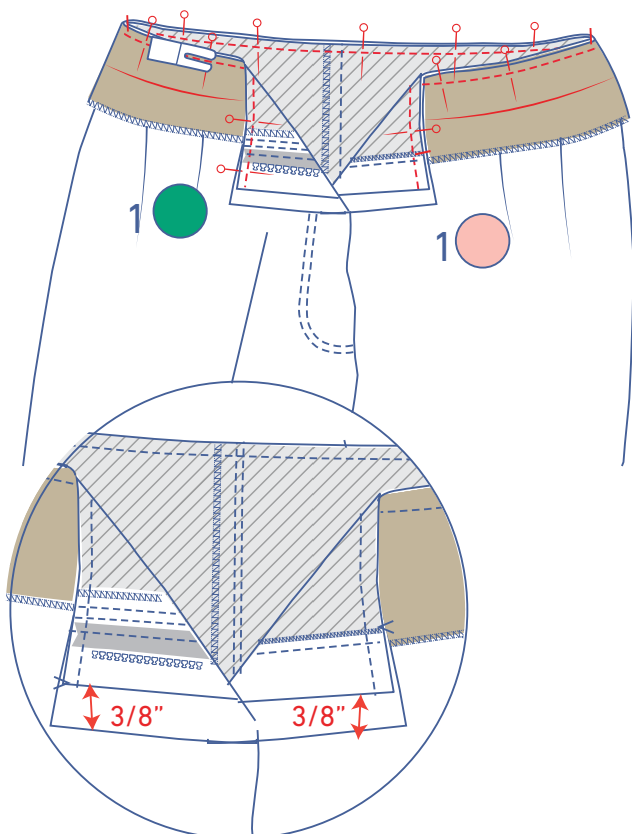

Pin the notched end of the waistband to the top of the trousers, making sure that the notches and side seams match. Sew into place. The short ends of the waistband should extend $\frac{3}{8}$ " past the finished CF on both sides.

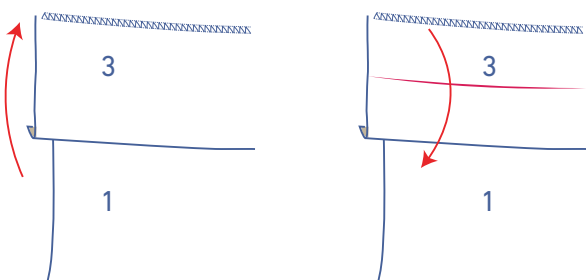

Open the waistband all the way out. Then, fold the overlocked top of the waistband back down along the fold line so that the right sides of the waistband are touching.

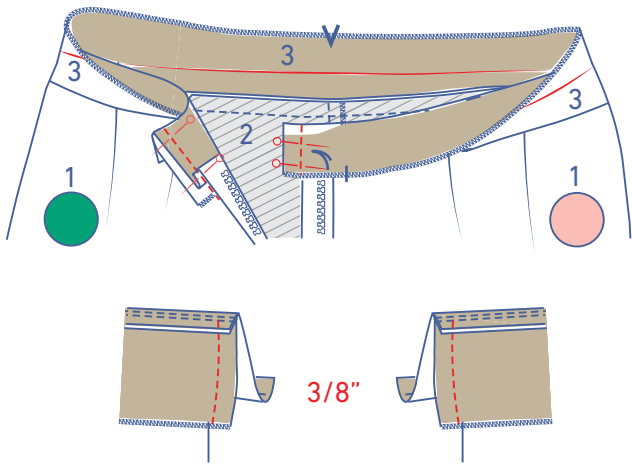

Sew the short ends closed.

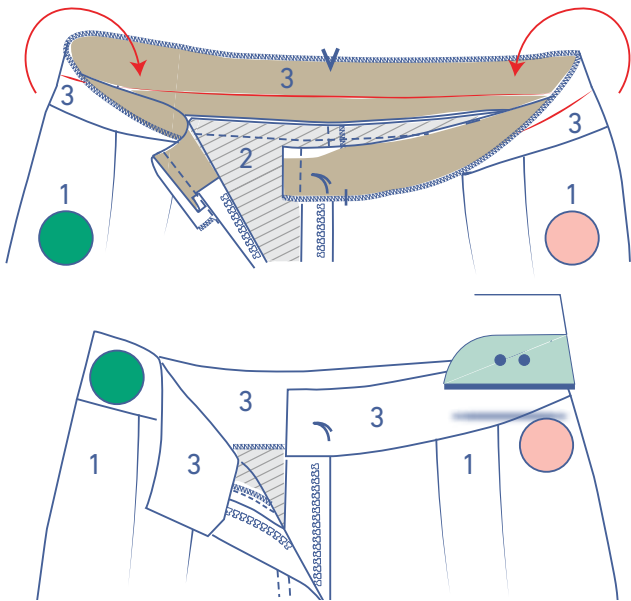

Now, turn the waistband the right way out and press neatly flat.

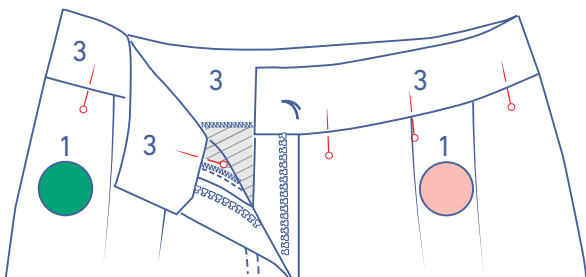

Pin the front and back of the waistband together along the right side of the garment.

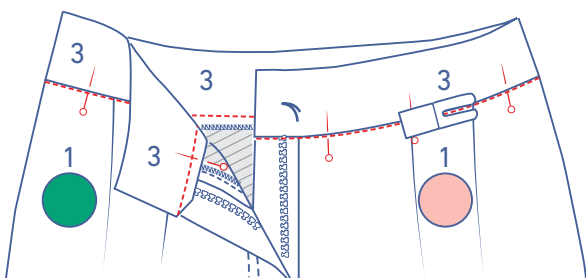

Stitch in the ditch.

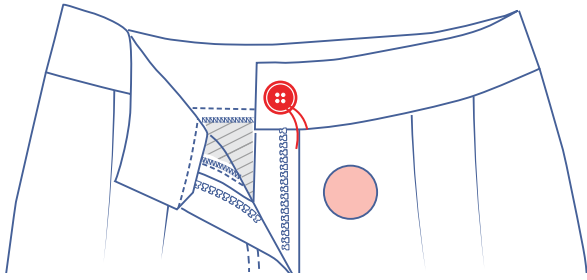

8

Sew the button to the waistband where indicated.

Make a horizontal buttonhole in the waistband to match.

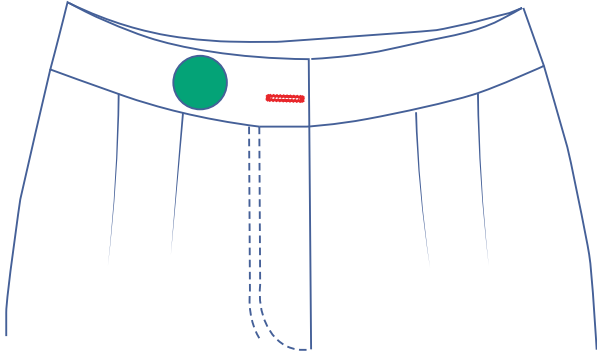

9

Press the hem allowance over at the V notches and then open back out.

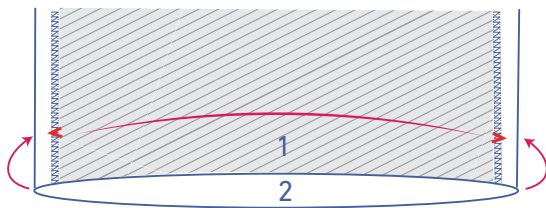
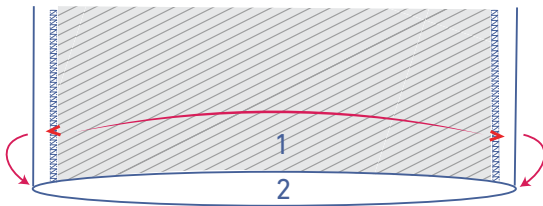
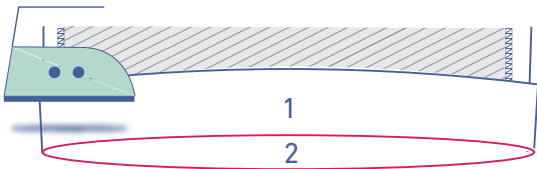

Fold the raw edge up to meet the fold line and then fold over again.

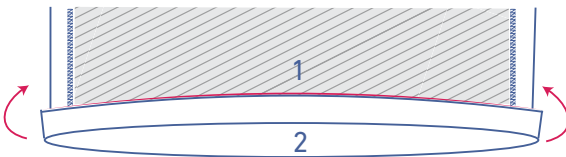

Sew the hem allowance into place right next to the seam.

