

# Odille by Fibre ⚡ood



# Odille by Fibre ood



**2 - 14 years**

Sometimes girls want to look a little more grown-up. This oversized dress with dropped short sleeves has a stylish collar and handy button closure. The details complete the picture with a yoke, gathers at the front and back, and oh-so-handy hidden side seam pockets. Select the length based on what works for you. We made our Tilda (just below) knee-length.

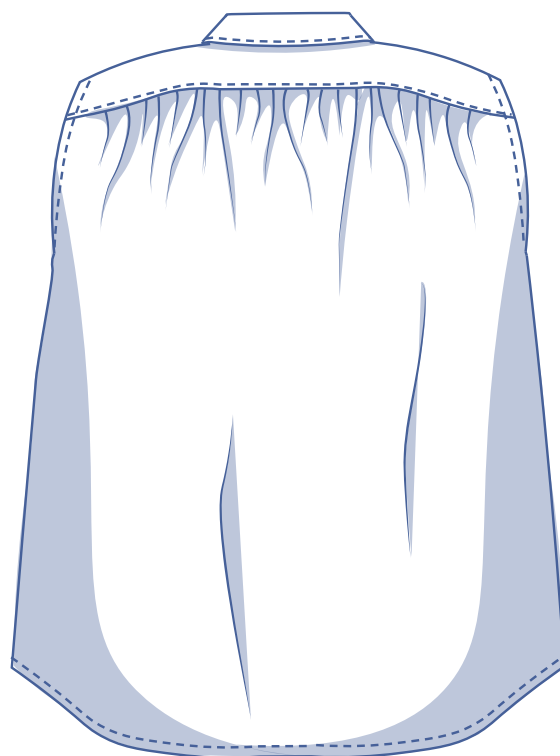
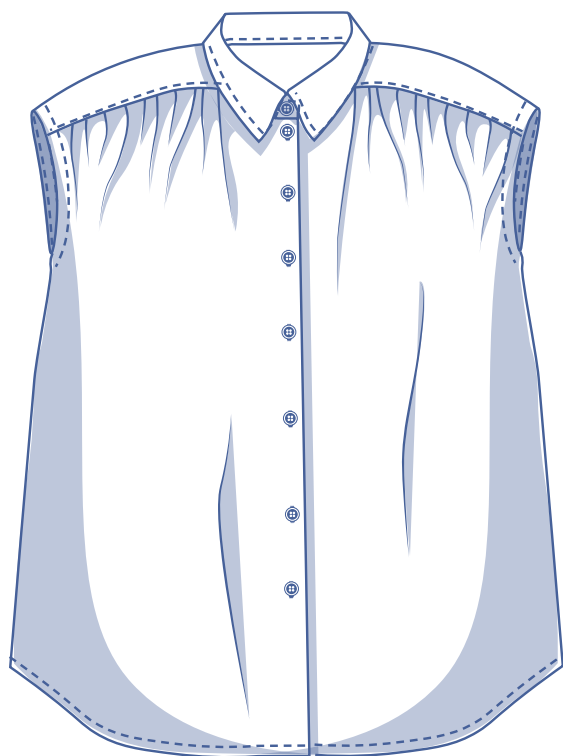

## size chart (in inches)

size	2	3	4	5	6	8	10	12	14
body height	3' 02"	3' 22"	3' 41"	3' 61"	3' 81"	4' 1"	4' 49"	4' 92"	5' 25"
C (chest)	20.5	21.3	22	22.8	23.6	25.2	26.8	28.3	29.9

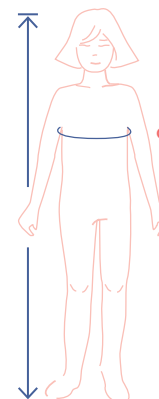

To select the right size for this pattern, the **chest measurement** should be your guideline (regardless of age or height). Pick the size closest to the actual chest measurements. Next, alter the length of the chosen size based on your child's age or height, listed in the table below.

## pattern measurements (in inches)

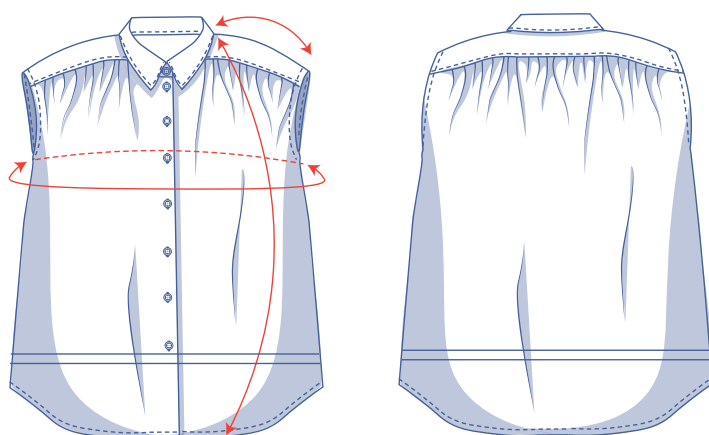

== shorten or lengthen the pattern here

This chart's measurements are the pattern measurements based on the fabric type and serve as a reference. Ease has been added to the width measurements (in addition to the exact body measurements) for a more comfortable fit. Odille is designed to have an **oversized cut**.

Not a fan of oversized? Just go a size smaller.

size	2	3	4	5	6	8	10	12	14
length	21	22.4	23.8	25.2	26.7	30.1	33.6	37	40.4
shoulder length	6.4	6.6	6.8	6.9	7	7.3	7.6	7.9	8.2
chest	38.3	39.1	39.9	40.7	41.4	43	44.6	46.2	47.8

Compare the stated lengths to the measured or desired lengths. **Lengthen** or **shorten** the dress by cutting the pattern pieces along the indicated double lines. Then either increase the distance between the cut pieces by the desired amount (to lengthen) or overlap the pieces (to shorten). Make sure that the CF and CB lines and the side seams are always straight.



### IMPORTANT

Adjust the amount of fabric to be used based on these alterations.

## notions

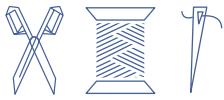

- Thread
- Buttons ( $\emptyset \frac{3}{8}$ " ): see table
- Iron-on interfacing: max. 1.1 yd
- Fabric: see table

buttons	2	3	4	5	6	8	10	12	14
	7	7	7	7	8	8	8	9	10

fabric		2	3	4	5	6	8	10	12	14
fabric width 43"	cm	1 ½	1 ½	1 ¾	1 ¾	2	2 ¼	2 ¼	2 ½	2 ¾
fabric width 55"	cm	1 ¼	1 ¼	1 ½	1 ½	1 ¾	1 ¾	1 ¾	2	2 ¼

The corresponding fabric layout can be found on page 6 of these sewing instructions.

## fabric advice



If flexibility is your byword, Odille won't disappoint. You can make this dress in viscose (crepe), poplin, linen, lyocell, chambray, and more. Fabric with a fluid drape will give you an understated look while more structured fabrics add a little more oomph.

# Proud to be #Sewista

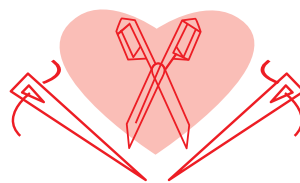

## pattern pieces & seam allowances (in inches)

To sew the garment as described in the instructions, draw the illustrated seam allowances around the paper pattern pieces before cutting them out. If you are using a PDF pattern, the pattern can be printed with or without seam allowance.

To find out more, watch the [video](#).

1. front: 2x
2. back: 1x on fabric fold
3. yoke: 2x on fabric fold
4. collar: 2x on fabric fold
5. collar band: 2x on fabric fold
6. bias tape: 2x
7. pocket: 4x

**IMPORTANT**

The pieces highlighted in light yellow have iron-on interfacing attached to the wrong side.

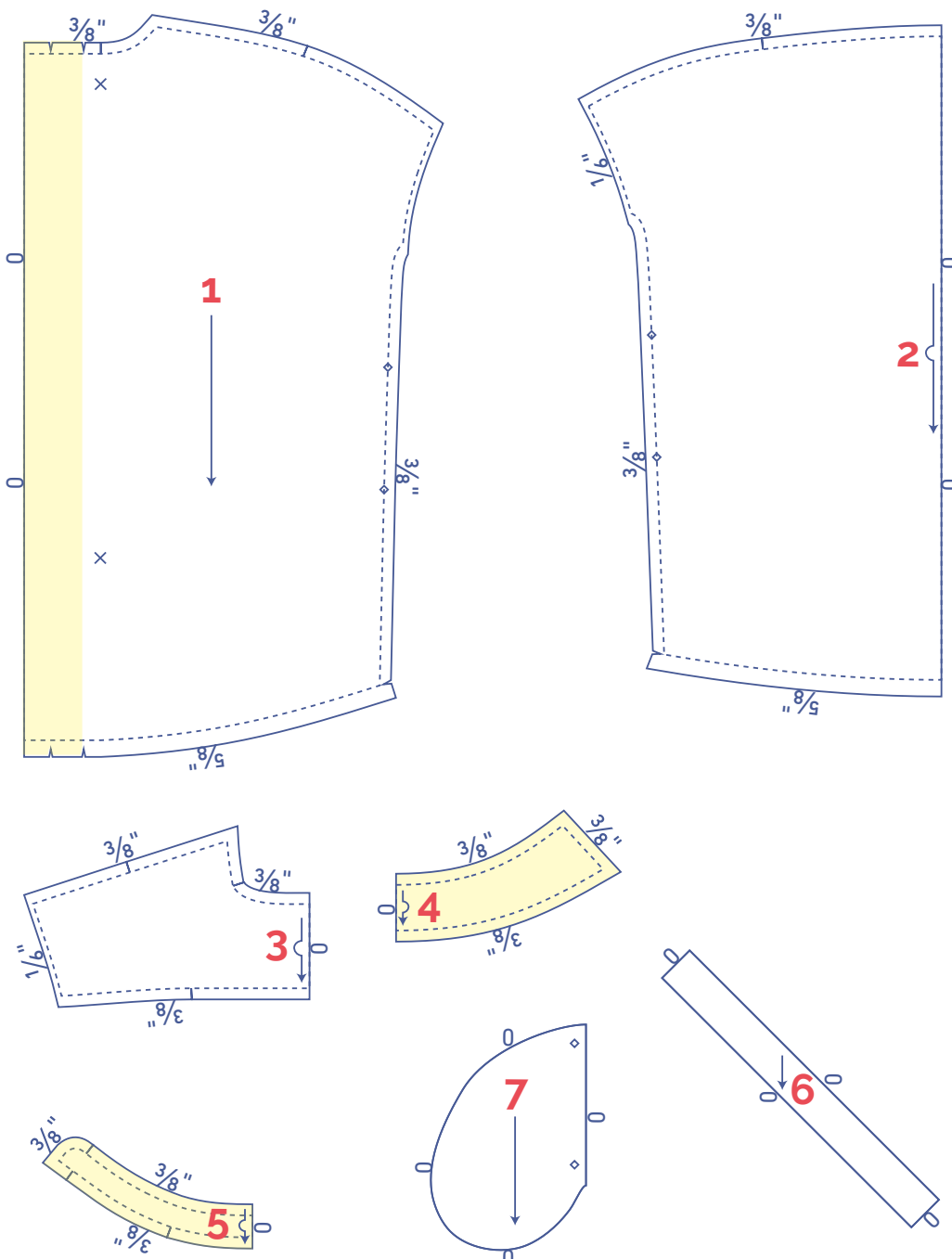

**fabric layout – solid fabrics**  
**fabric width 43"**

2 - 5 years

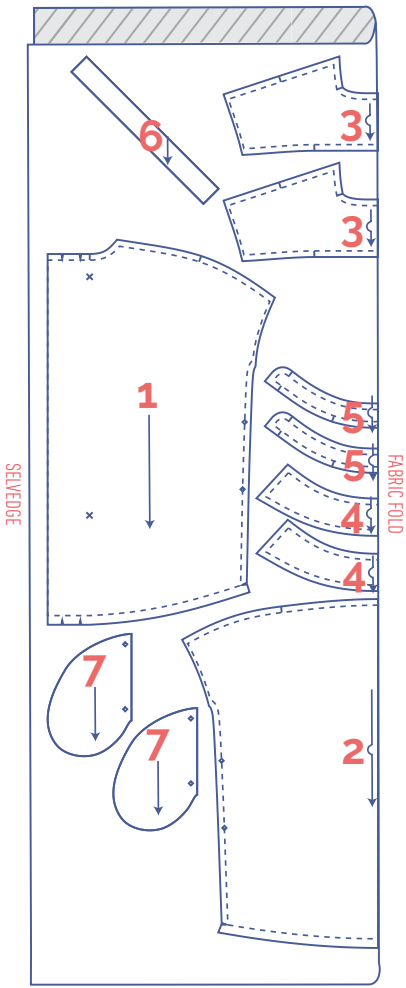

6 - 14 years

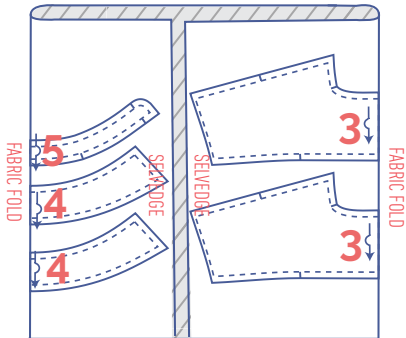
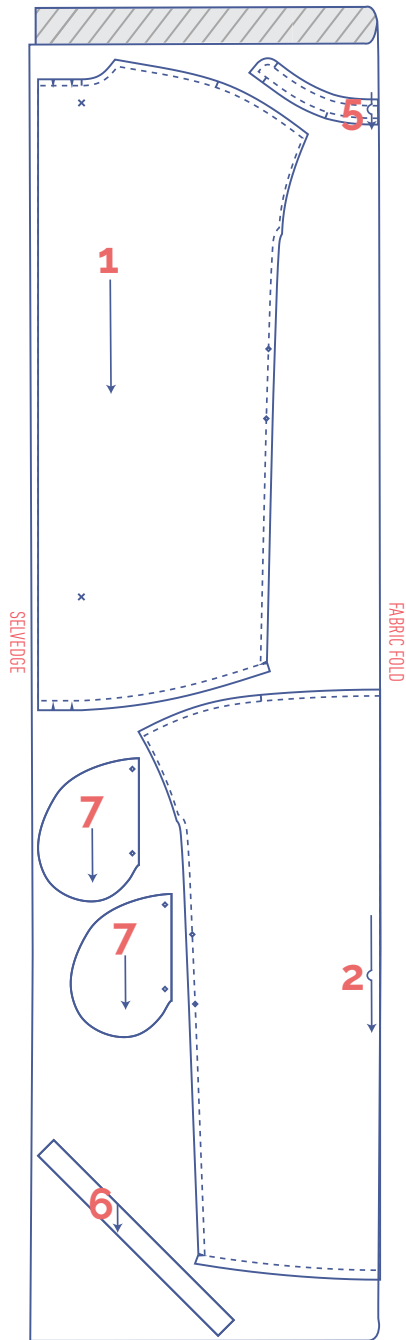



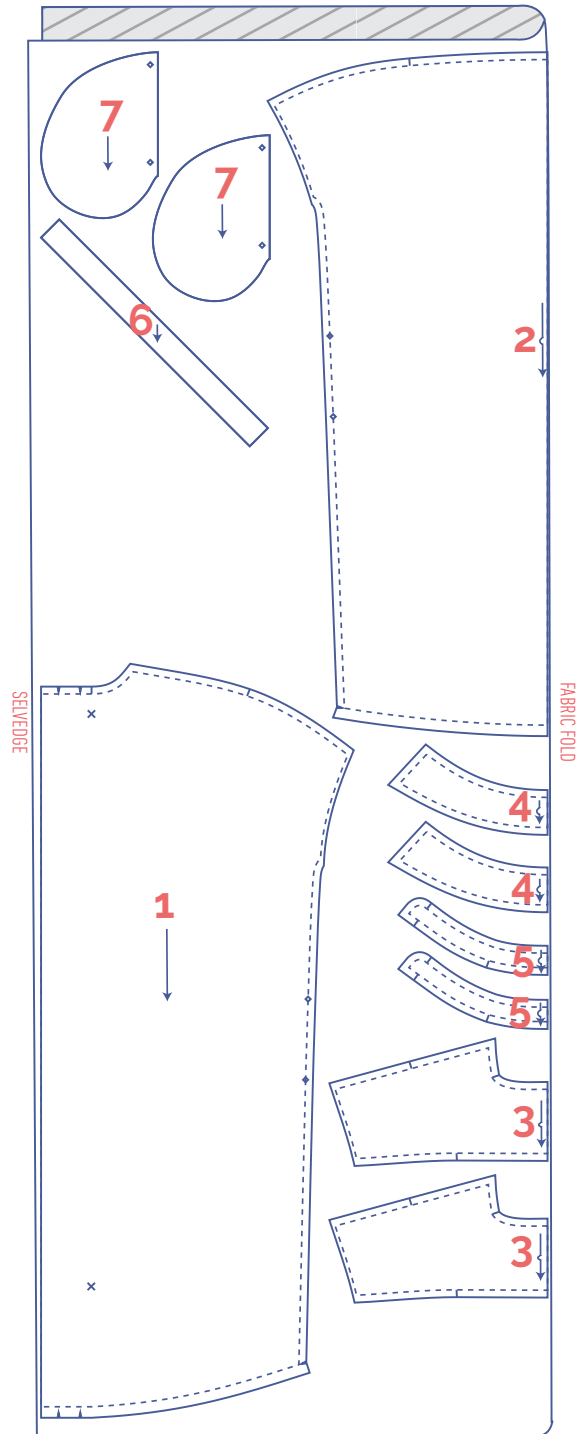
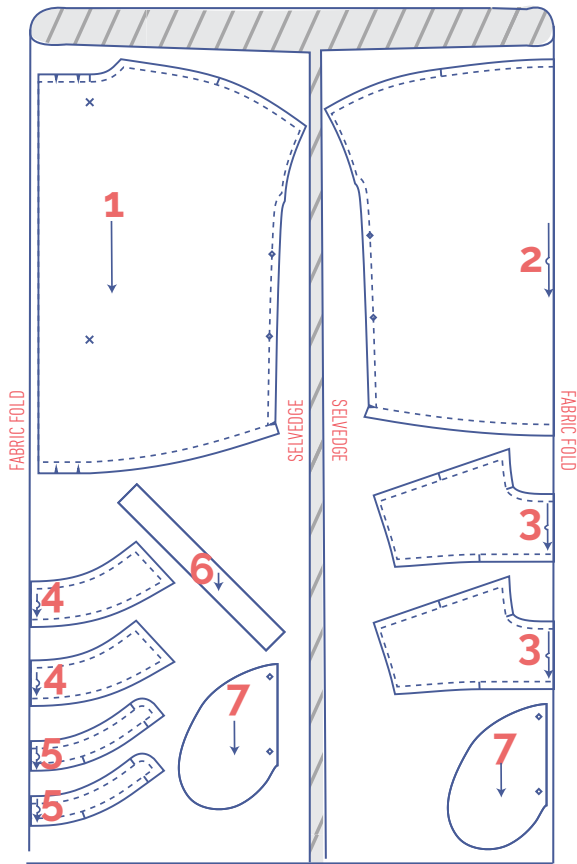

**fabric layout – solid fabrics**  
**fabric width 55"**

2 - 3 years

4 - 14 years



**marking pattern pieces**



	Notch the pattern paper and fabric at the following points
	single notch
	double notch
V	V notch
	Mark the following points using marking thread
	centre point
	buttons

# sewing instructions



The method used to finish the seams depends on the fabric used. The pieces are always sewn together with the right sides of the fabric matching, unless stated otherwise.



F	front
B	back
RF	right front ●
LF	left front ●
CF	centre front
CB	centre back
	right side
	wrong side
	iron-on interfacing

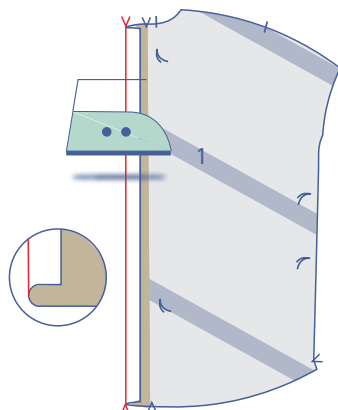
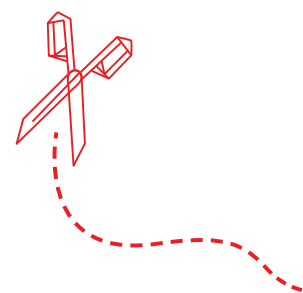

## 1

Press the front facing (1) over to the wrong side from the first set of V-notches at the top and bottom.



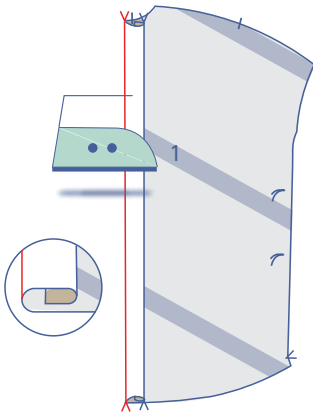

Then press the facing over again at the second set of V notches at the top and bottom.

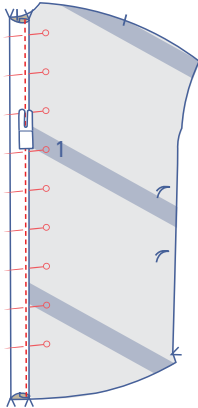

Edgestitch into place.

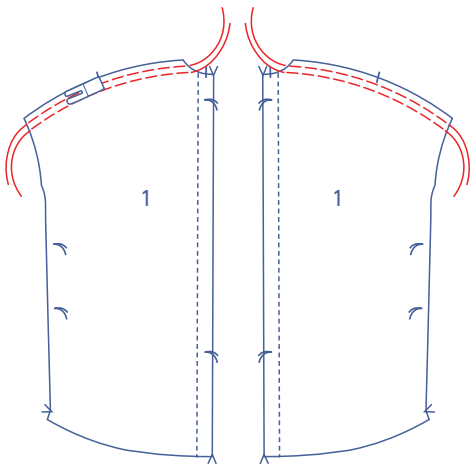

## 2

Sew two parallel lines of stitching at presser foot width from the top of the front, using a long stitch at a low thread tension. Leave a length of thread at the start and end of the rows.

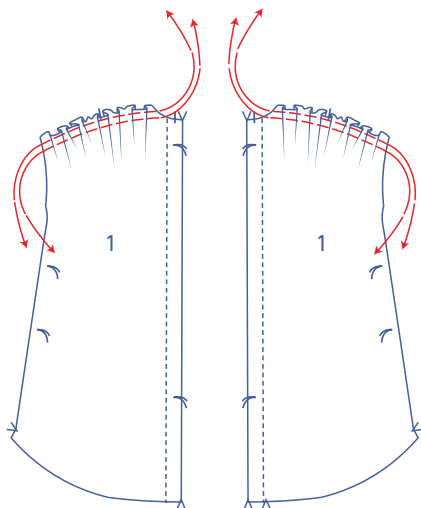

Carefully tug the ends of the threads to gather the fabric.

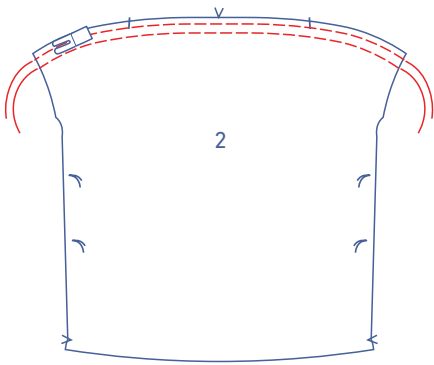

### 3

Sew 2 parallel lines of stitching at the top of the back (2) using a long stitch length at a low thread tension. Leave a length of thread at the start and end of the rows.

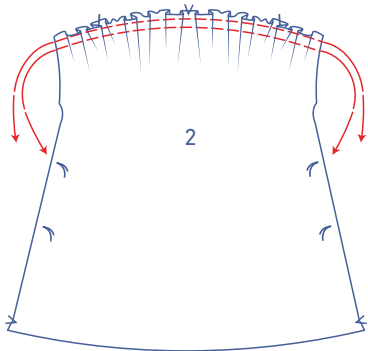

Carefully tug the ends of the gathering threads to gather the fabric.

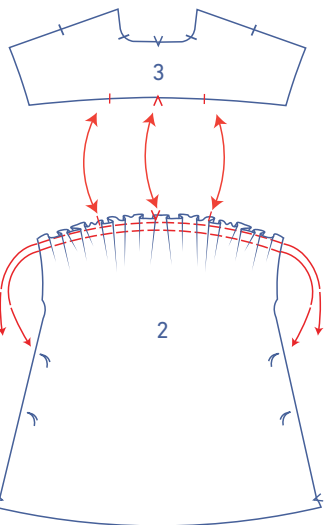

Distribute the gathers so that the notches in the back match the notches in the yoke (3).

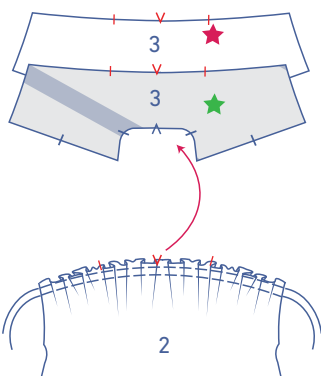

Place the yoke pieces on top of each other as shown. The outer yoke piece is marked with a green star, while the yoke piece with a red star will eventually be situated on the inside of the garment. Now slide the back piece between them (the right side of the back facing up), matching notches.

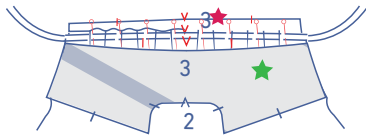

Pin and sew into place.

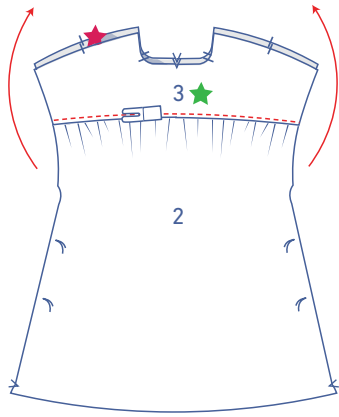
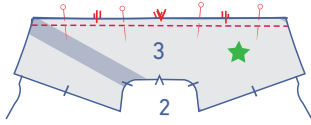

Fold both yoke pieces back up. The back should be neatly positioned between the two pieces. Topstitch right next to the seam.

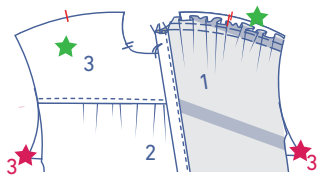

Place the shoulder line of the front and green-star (outer) yoke on top of each other with the right sides facing. Distribute the gathers so that the notch in the front match the notches in the yoke.

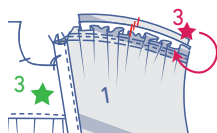
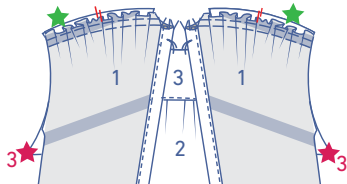

Now, take the shoulder line of the red-star (inner) yoke and fold this to the front with the right side facing down onto the wrong side of the front. Neatly match the 3 raw edges and sew to anchor through all layers.

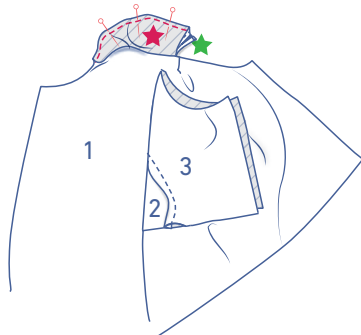

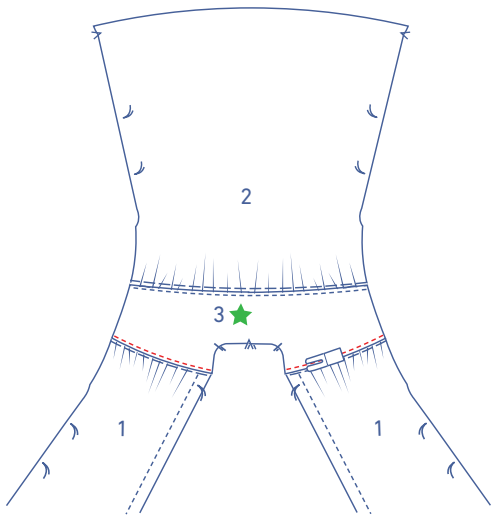

Open back out so that the wrong sides are facing. The shoulder line of the front should be neatly positioned between the yoke pieces. Topstitch right next to the seam.

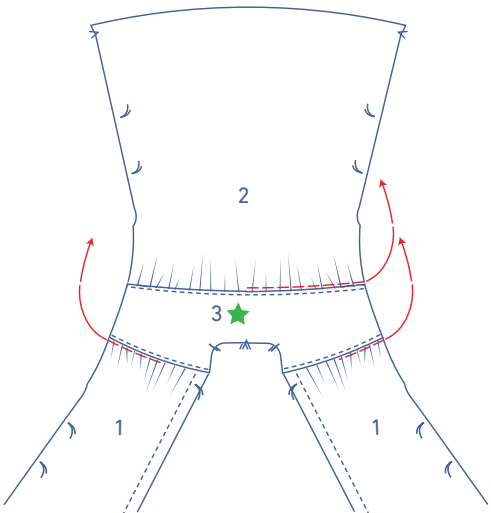

Remove the gathering threads.

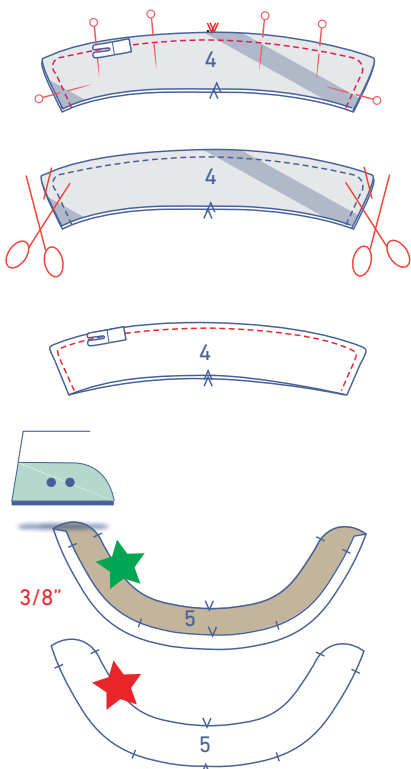

## 4

Pin and sew the contours of the collars (4) together as shown.

Grade the seam allowance at the corners.

Turn the collar the right way out and topstitch the contours right next to the edge.

Press one of the two collar bands (5)  $\frac{3}{8}$ " over towards the wrong side at the bottom. We've marked this collar band with a green star.

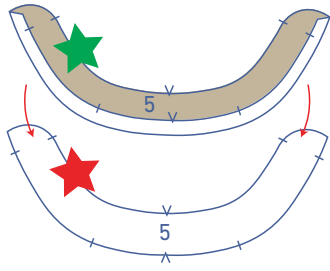

Stack both collar bands with the right sides facing. The collar band with the pressed bottom (green star) should be on top.

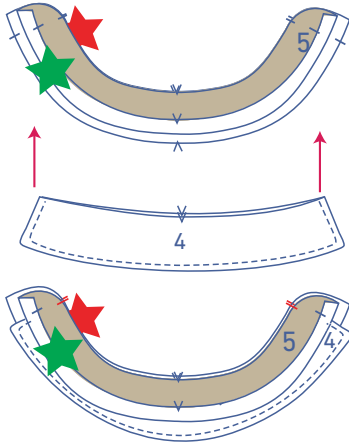

Slide the collar between the 2 collar bands and align the raw edges. The finished edge of the collar matches the notch in the collar band.

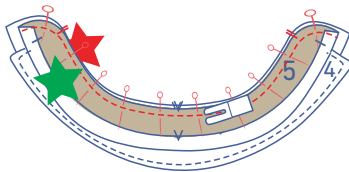

Pin and sew the pieces together.

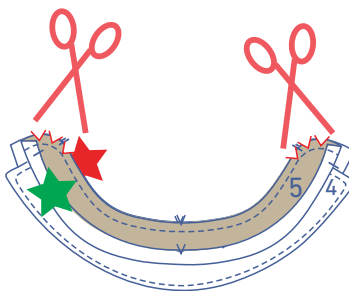

Notch the seam allowance in the curves.

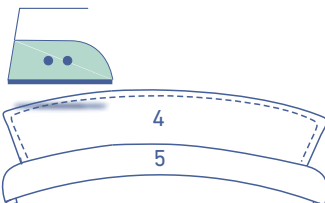

Turn out the collar bands the right way around.

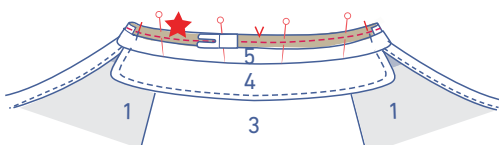

Pin and sew the bottom of the unpressed collar band (red star) to the neckline along the wrong side of the garment, matching notches.

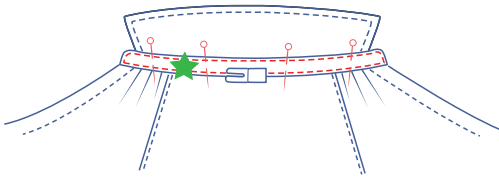

Fold the collar band with the pressed bottom (green star) towards the right side of the neckline. The fold line should be directly over the previous stitching. Pin and sew into place and continue topstitching all the way around the collar band.

## 5

Finish the indicated raw edges with overlock stitching.

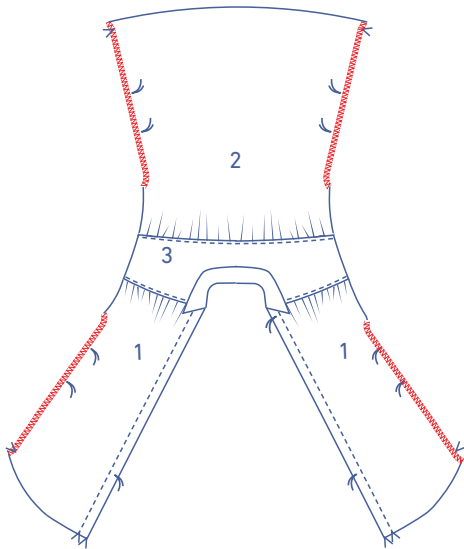

Finish the straight ends of the pocket pieces (7) with overlock stitching.

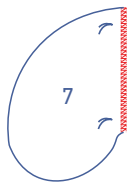

Pin the straight ends of 2 of the 4 pocket pieces to either side of the front, matching the marking threads. Sew into place between the marking threads.

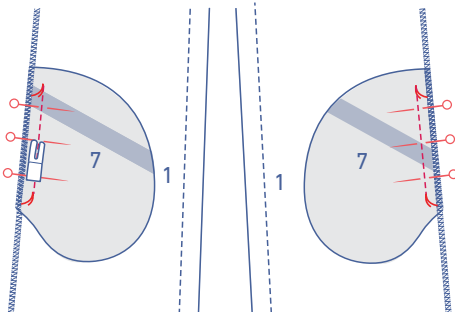

Fold the pocket and seam allowance over and sew the pocket to the seam allowance underneath.

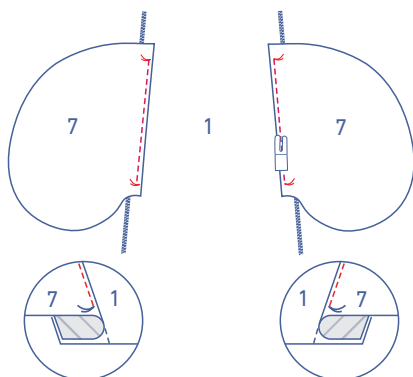

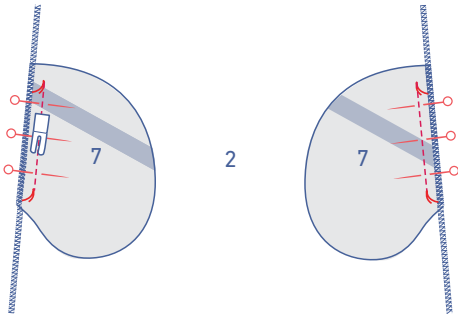

Pin the straight ends of the remaining pocket pieces to the sides of the back, matching the marking threads. Sew into place between the marking threads.

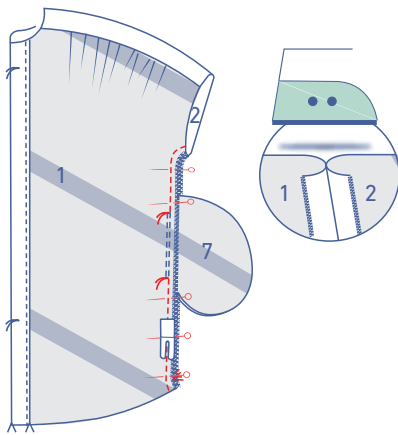

## 6

Pin and sew the side and underarm seams. Sew from the sleeve hem right up to the marking thread that marks the top of the pocket opening. Now, sew from the next marking thread down to the hem. Press the seam allowance open.

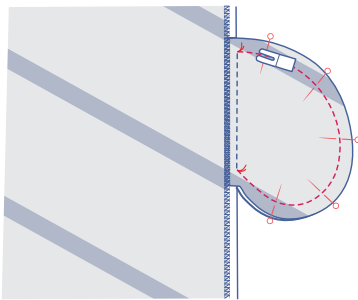

Pin and sew the contours of the pocket pieces together at  $\frac{5}{8}$ ".

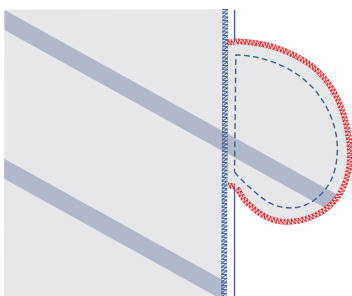

Finish the raw edges with overlock stitching.

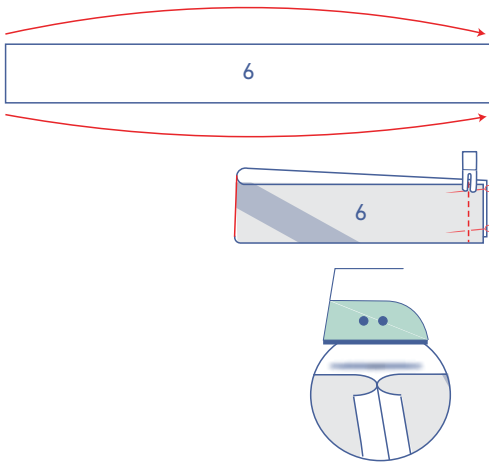

## 7

Stitch the short ends of the bias tape pieces (6) together with the right sides of the fabric facing. Press the seam open.

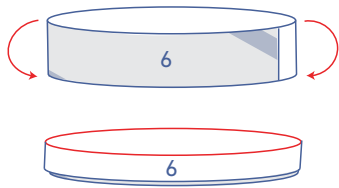

Fold the bias tape in half with the long ends together and the wrong sides of the fabric facing.



Pin both raw edges of the bias tape to the right side of the armhole. Stitch into place at  $\frac{1}{6}$ ".

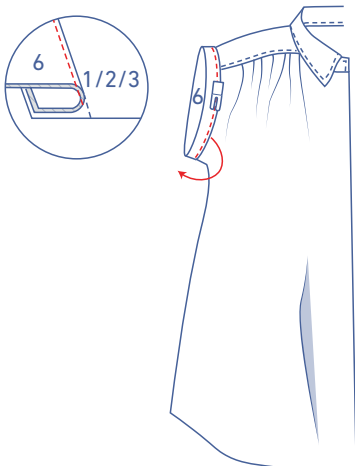

Fold the bias tape and seam allowance over and stitch the bias tape to the seam allowance right next to the seam.



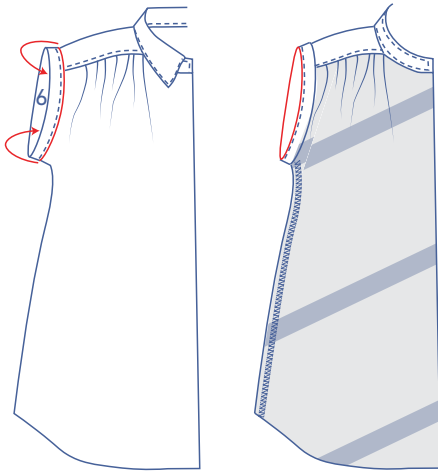

Fold the bias tape all the way over to the wrong side.

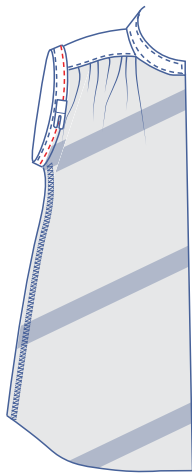

Stitch into place right next to the edge.

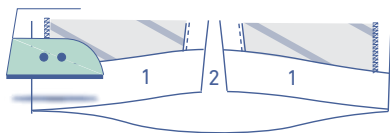

## 8

Press the hem allowance up at the V notches and then open back out.

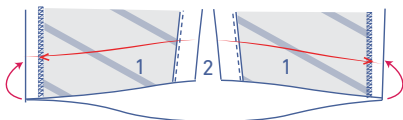
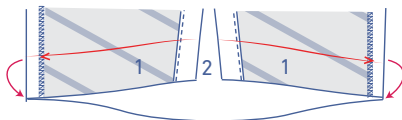

Fold the raw edge over to the pressed fold line and fold over again.

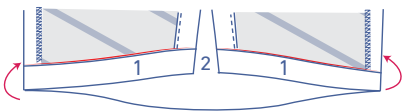

Sew into place next to the edge.

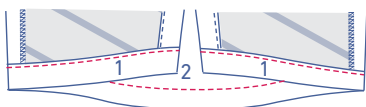

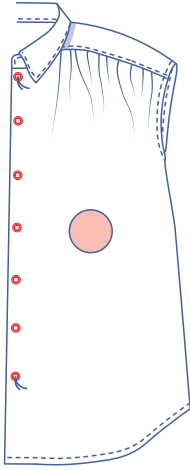

## 9

Sew the buttons to the LF. The positions of the top and bottom buttons have been marked on the pattern for you. Divide the distance equally to determine the location of the other buttons.

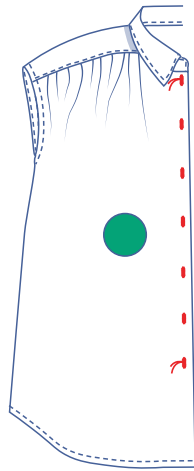

Make vertical buttonholes in the RF based on the location of the buttons.

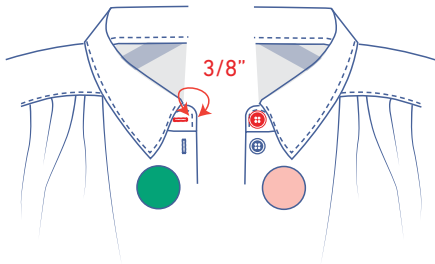

Make a horizontal buttonhole on the right side of the collar band halfway up at  $\frac{3}{8}$ " from the finished edge. Sew a button to match on the other side of the collar band.