

Micky by Fibre ⚡ood



Micky by Fibre ood

Without welt pockets



With welt pockets



2 - 14 years

Micky is your unisex go-to for bridging the mid-season gap. When it's still too warm for a coat, this bodywarmer with standing collar and practical snap closure is sure to come in handy. It's up to you whether you add the welt flap pockets and thread elastic through the sleeve trim and hem bands.

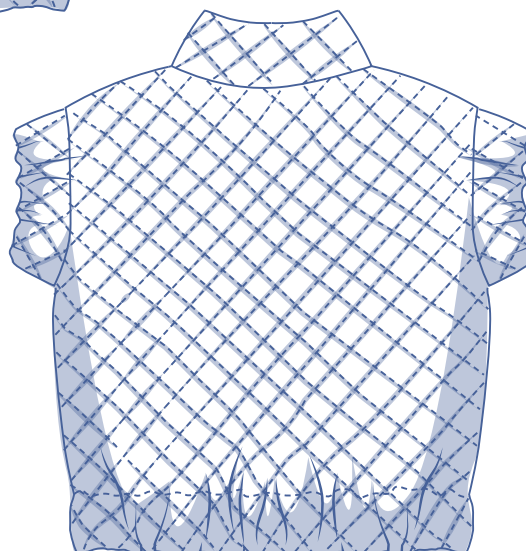

size chart (in inches)

size	2	3	4	5	6	8	10	12	14
body height	3' 02"	3' 22"	3' 41"	3' 61"	3' 81"	4' 1"	4' 49"	4' 92"	5' 25"
C (chest)	20.5	21.3	22	22.8	23.6	25.2	26.8	28.3	29.9

To select the right size for this pattern, the **chest measurement** should be your guideline (regardless of age or height). Pick the size closest to the actual chest measurements. Next, alter the length of the chosen size based on your child's age or height, listed in the table below.

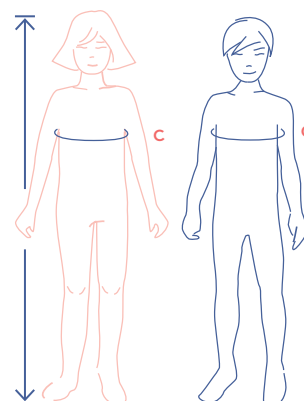

pattern measurements (in inches)

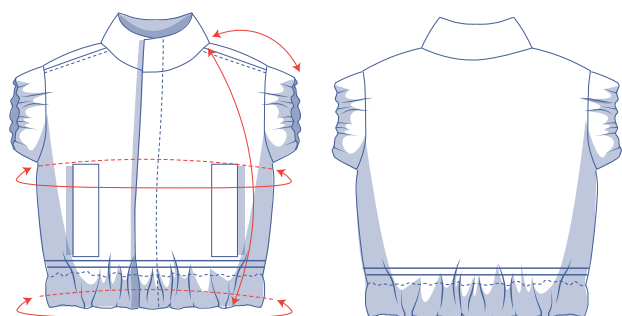

This chart's measurements are the pattern measurements based on the fabric type and serve as a reference. Ease has been added to the width measurements (in addition to the exact body measurements) for a more comfortable fit. Micky is designed to have a **relaxed cut**.

==== shorten or lengthen the pattern here

size	2	3	4	5	6	8	10	12	14
length	14.2	14.8	15.9	16.9	18.0	20.0	22.1	24	26.2
sleeve length*	5.2	5.4	5.6	5.7	5.8	6.2	6.4	6.7	7.1
chest	30.8	31.5	32	33.1	33.9	35.5	37.1	38.6	40.2
hem circumference with elastic	21.8	22.4	23	23.5	24.1	25.2	26.3	27.5	28.6
hem circumference without elastic	30.9	31.6	32	33.2	34.0	35.6	37.2	38.7	40.4

* Including shoulder length.

Compare the stated lengths to the measured or desired lengths. **Lengthen** or **shorten** the body warmer by cutting the pattern pieces at the indicated double lines. Then either increase the distance between the cut pieces by the desired amount (to lengthen) or overlap the pieces (to shorten). Make sure that the CF and CB lines and the side seams are always straight.



IMPORTANT

Adjust the amount of fabric to be used based on these alterations.

notions



- Thread
- Iron-on interfacing: max. $\frac{1}{10}$ yd
- Snaps ($\emptyset \frac{5}{8}$ "): see table
- Elastic (width $1 \frac{3}{5}$ "): see table
- Fabric: see table

snaps	2	3	4	5	6	8	10	12	14
	6	6	6	7	7	7	7	8	8

elastic		2	3	4	5	6	8	10	12	14
cuff	cm	2x39	2x40	2x42	2x43	2x44	2x46	2x48	2x50	2x52
hem band	cm	0.66	0.68	0.69	0.70	0.72	0.75	0.79	0.82	0.84
total	cm	1.44	1.49	1.52	1.55	1.60	1.67	1.75	1.83	1.89

fabric		2	3	4	5	6	8	10	12	14
fabric width 43"	cm	1	1	1 $\frac{1}{4}$	1 $\frac{1}{4}$	1 $\frac{1}{4}$	1 $\frac{1}{2}$	1 $\frac{3}{4}$	1 $\frac{3}{4}$	2
fabric width 55"	cm	1	1	1	1	1	1 $\frac{1}{4}$	1 $\frac{1}{4}$	1 $\frac{1}{2}$	1 $\frac{1}{2}$

The corresponding fabric layout can be found starting on page 6 of these sewing instructions.

fabric advice This ultra-cosy bodywarmer begs to be made in padded or quilted fabric or a homely sweatshirt fabric.



Proud to be #Sewista

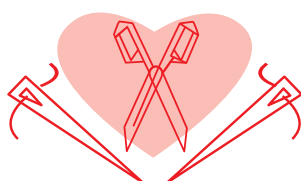

pattern pieces & seam allowances (in inches)

To sew the garment as described in the instructions, draw the illustrated seam allowances around the paper pattern pieces before cutting them out. If you are using a PDF pattern, the pattern can be printed with or without seam allowance.

To find out more, watch the [video](#).

1. front: 2x
2. back: 1x on fabric fold
3. collar: 1x on fabric fold
4. collar facing: 1x on fabric fold
5. cuff: 2x
6. welt: 2x
7. inner pocket bag: 2x
8. pocket opening: 2x
9. hem facing: 1x on fabric fold

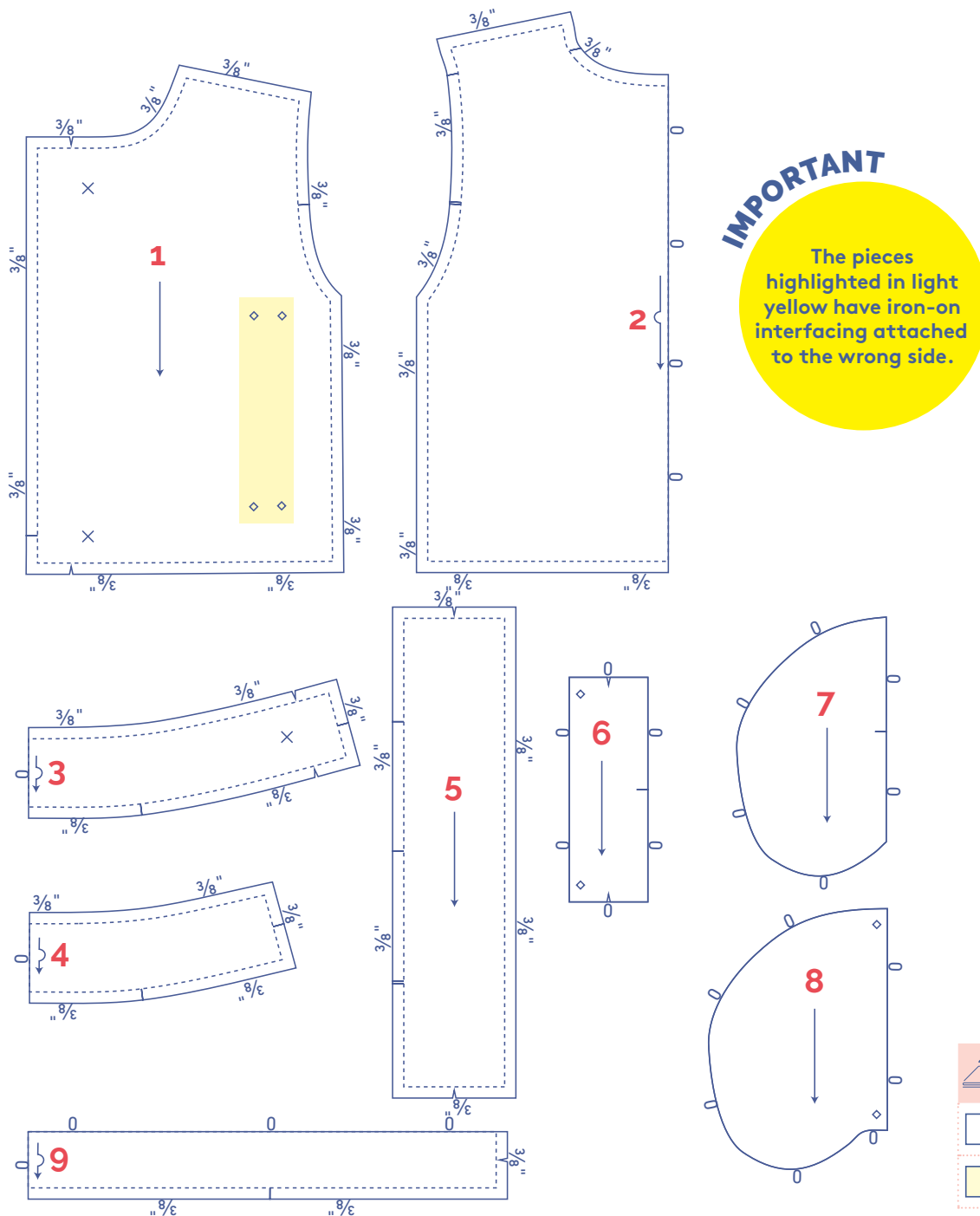

fabric layout – solid fabrics
fabric width 43"

2 - 6 years

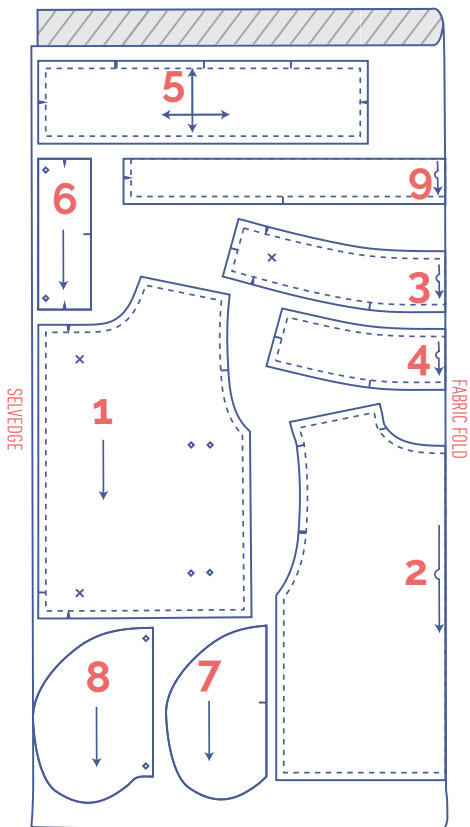

8 - 14 years

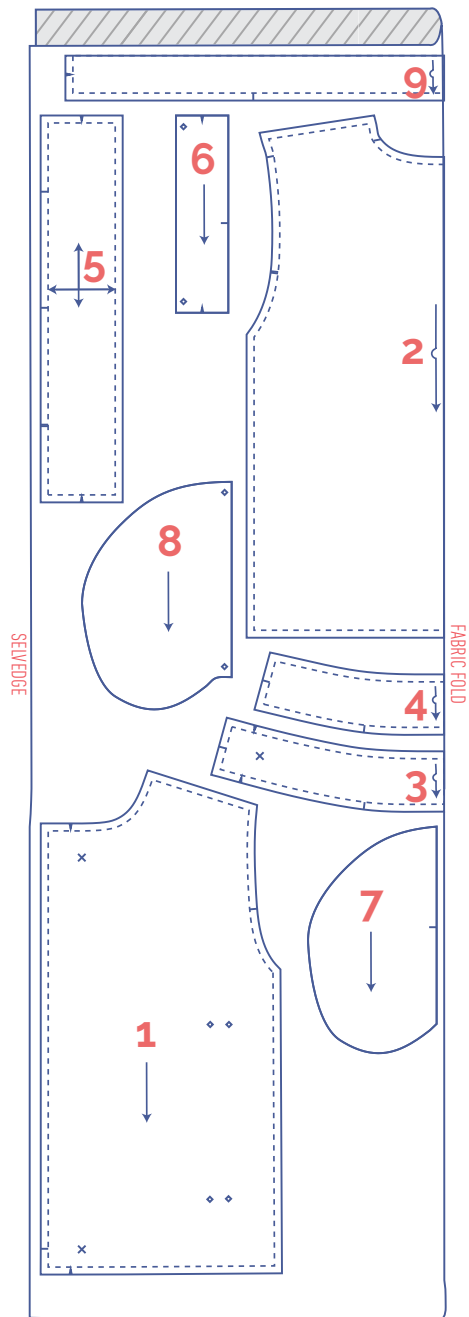

fabric layout – solid fabrics
fabric width 55"

2 - 8 years

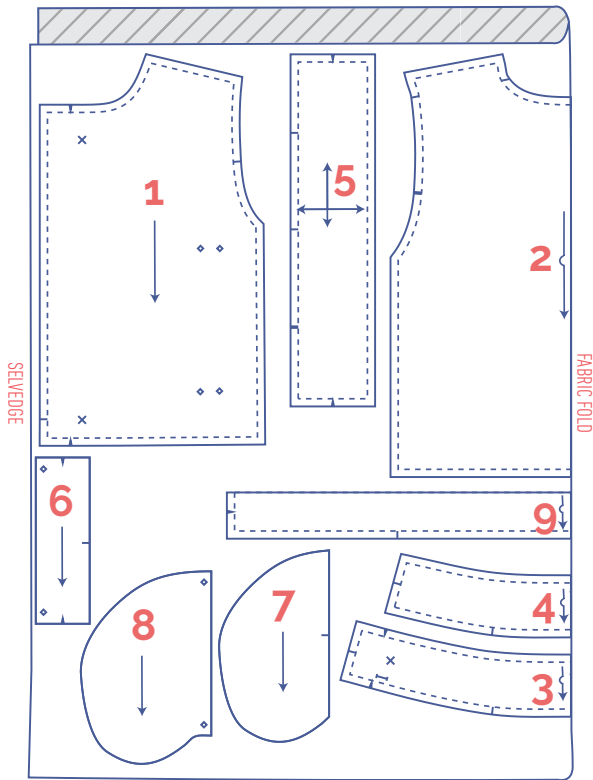

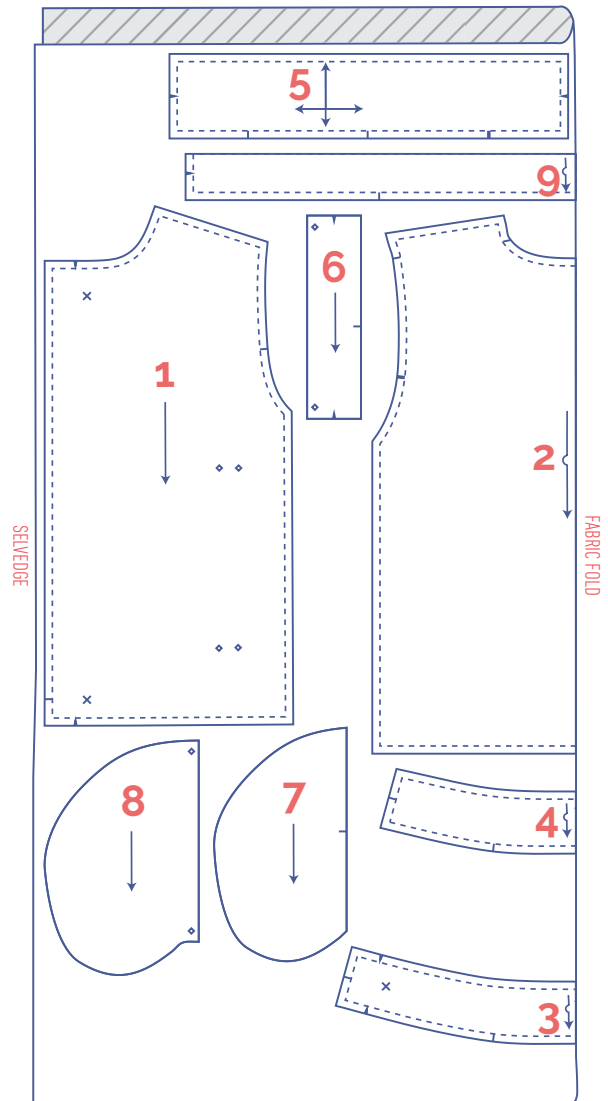

10 - 14 years



marking pattern pieces

	Notch the pattern paper and fabric at the following points
	single notch
	double notch
∨	V notch

	Mark the following points using marking thread
	centre point
	buttons

sewing instructions



The method used to finish the seams depends on the fabric used.
The pieces are always sewn together with the right sides of the fabric facing, unless stated otherwise.

F front

B back

RF right front ●

LF left front ●

CF centre front

CB centre back

□ right side

▨ wrong side

▨ iron-on interfacing

▨ elastic

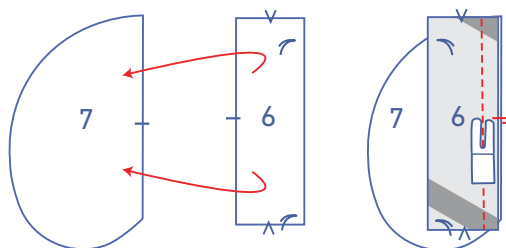

1

Pin the notched long end of the welt (6) and the inner pocket bag (7) together.

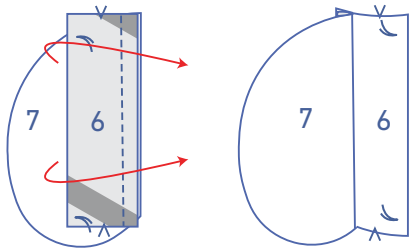

Open up the pieces and press the seam allowance towards the inner pocket bag.

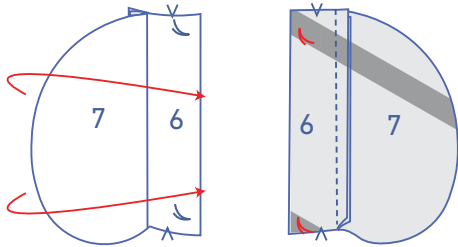

Turn the welt + inner pocket bag over so that the wrong side is facing up.

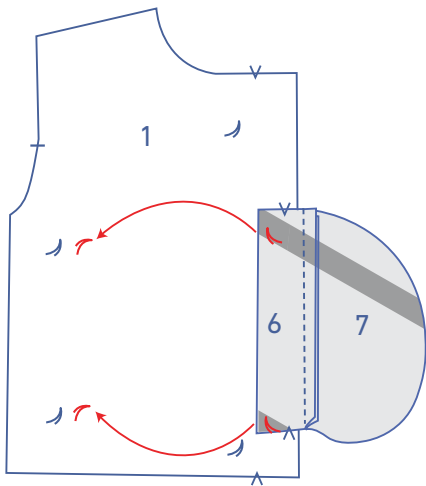

Pin the marking threads of the welt to the bottom marking threads indicated on the front (1).

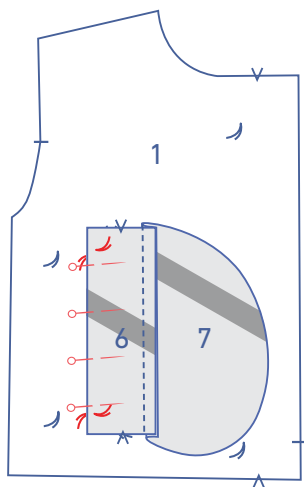

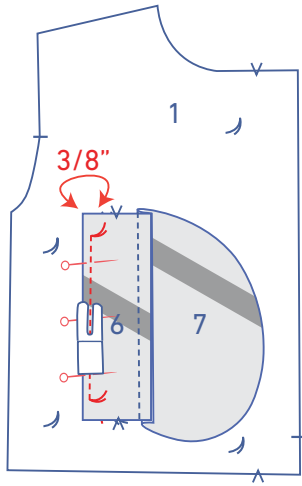

Sew into place between the marking threads at $\frac{3}{8}$ " from the raw edge.

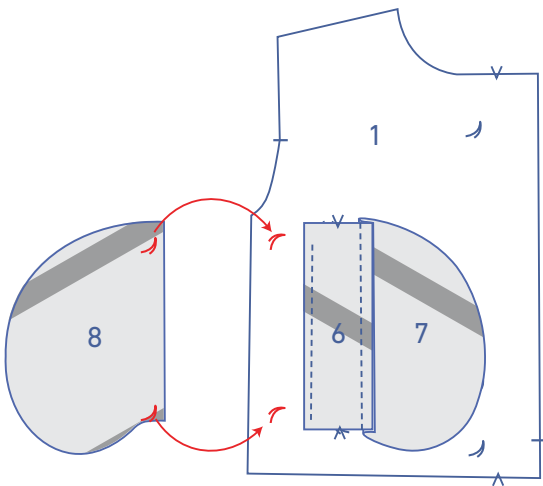

Pin the pocket opening (8) to the front, right sides together, matching marking threads as shown.

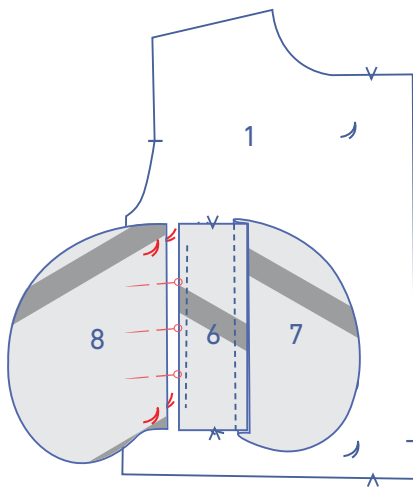

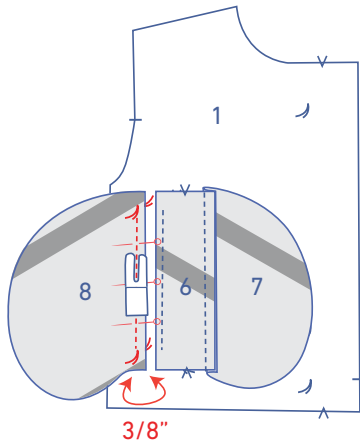

Sew into place between the marking threads at $\frac{3}{8}$ " from the raw edge.

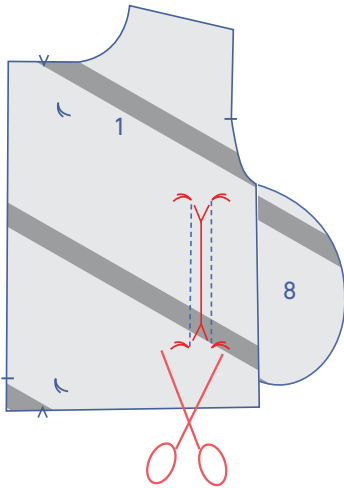

Turn the front over with the wrong side facing up. Snip between the two rows of stitching, stopping just a little way from the start and end of the stitching. From here, snip diagonally to the last stitch at the start and end of each row of stitching as shown (applique scissors are useful if you have them).

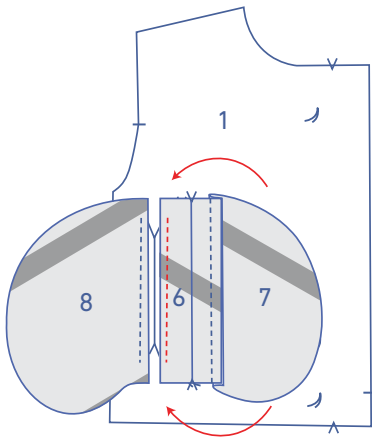

Now turn over your work so the front is facing up. Now, fold the welt + inner pocket bag all the way over with the right side facing up.

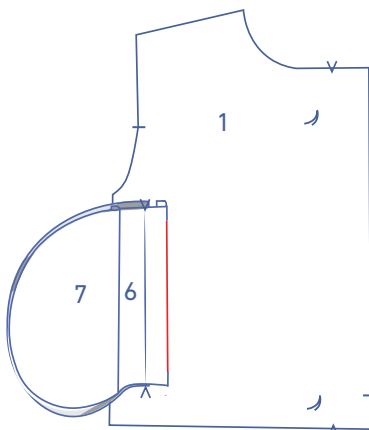

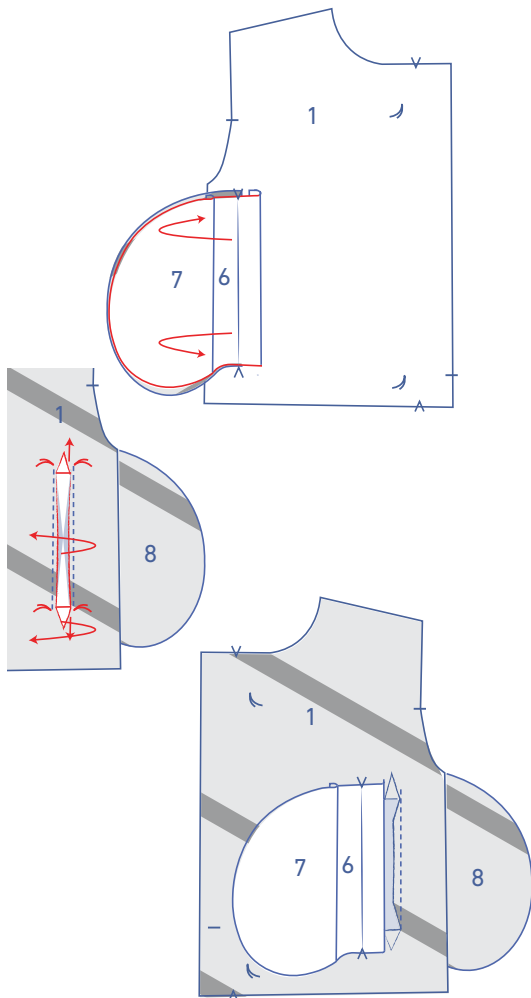

Push the welt and inner pocket through the opening towards the wrong side of the front. Push the triangles (created by your diagonal snips) through the opening at the same time.

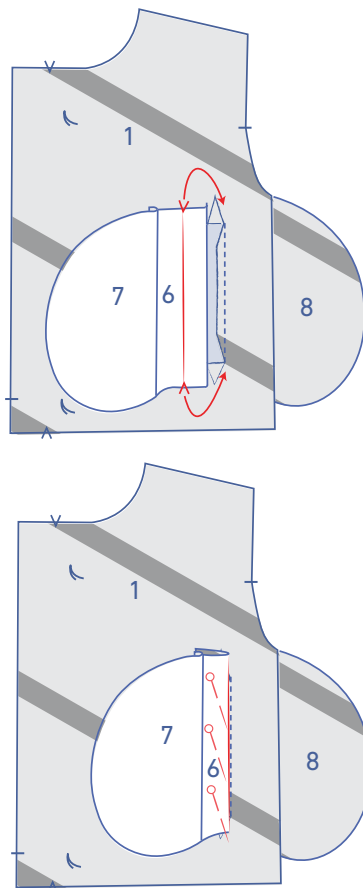

Press the welt over at the V notches. Place the fold line over the indicated stitching and pin temporarily into place.

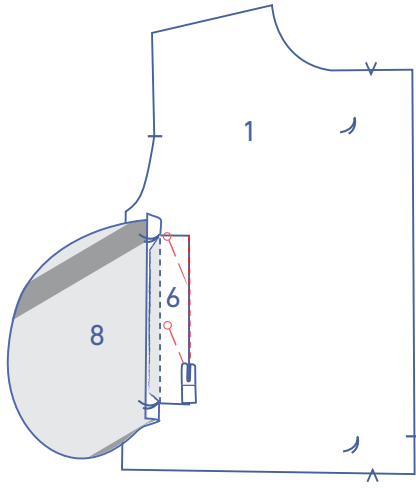

Turn the front over so that the right side is facing up. Lay the welt and inner pocket bag neatly flat and stitch in the ditch.

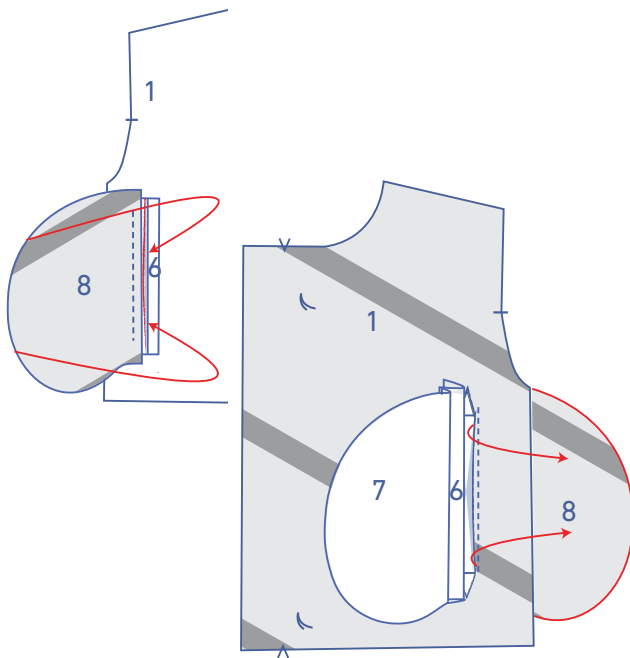

Fold the pocket opening over with the right side facing up. Push this through the opening to the wrong side of the front.

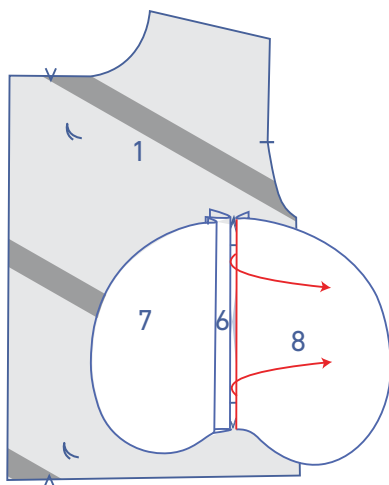

Lay all pieces neatly flat.

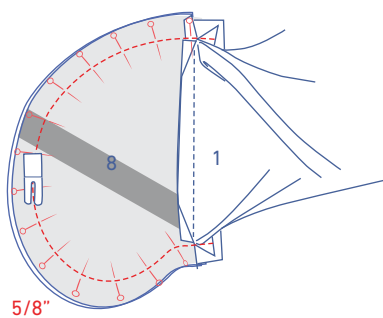
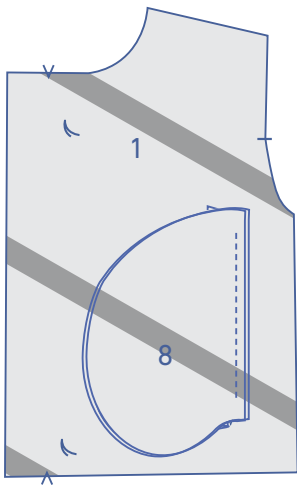
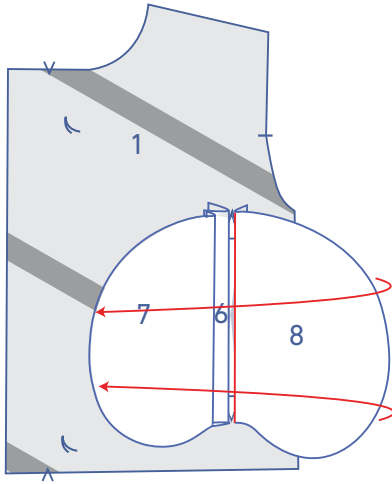

Move the front out of the way and pin the pocket pieces together. Start sewing to secure one triangle, then continue sewing the contours of the pocket pieces together at $\frac{5}{8}$ ", and finish with the other triangle as shown.

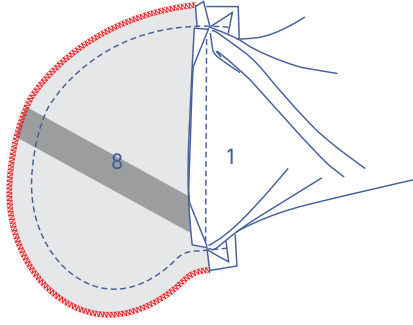

Finish the raw edges of the pocket with overlock stitching.

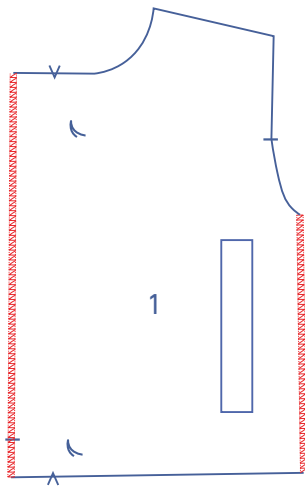

Finish the CF and sides with overlock stitching.

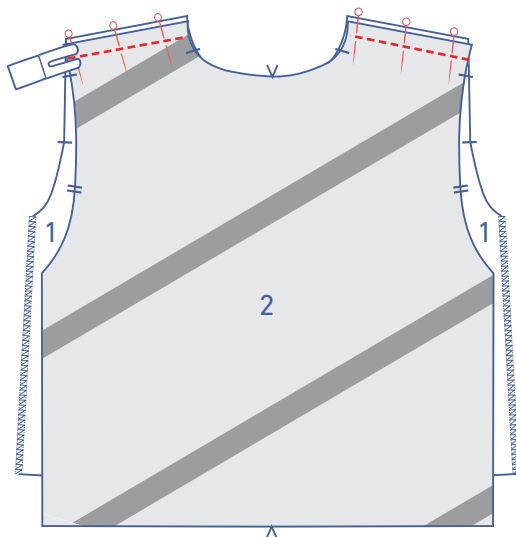

2

Pin and sew the shoulder seams of the front and back (2) together.

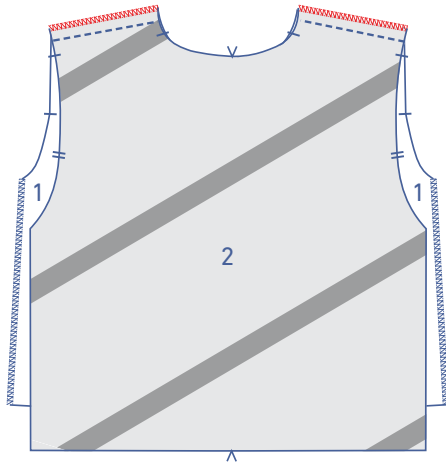

Finish the raw edges with overlock stitching.

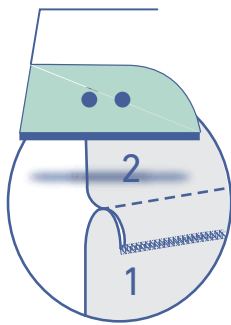

Press the seam allowance towards the front.

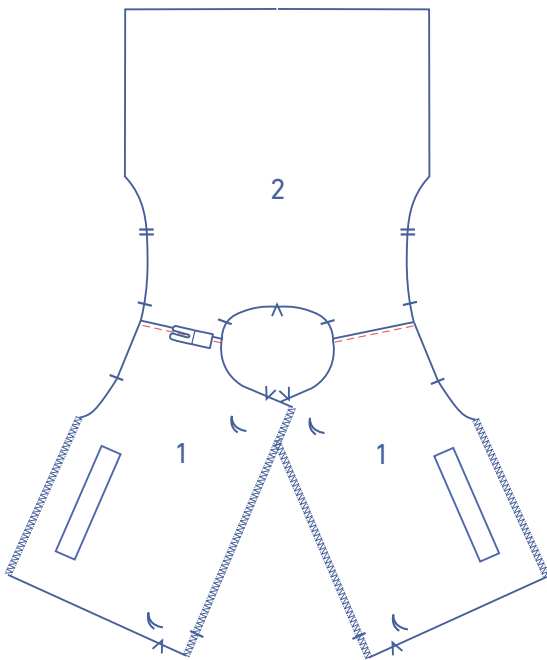

Topstitch the front right next to the seam.

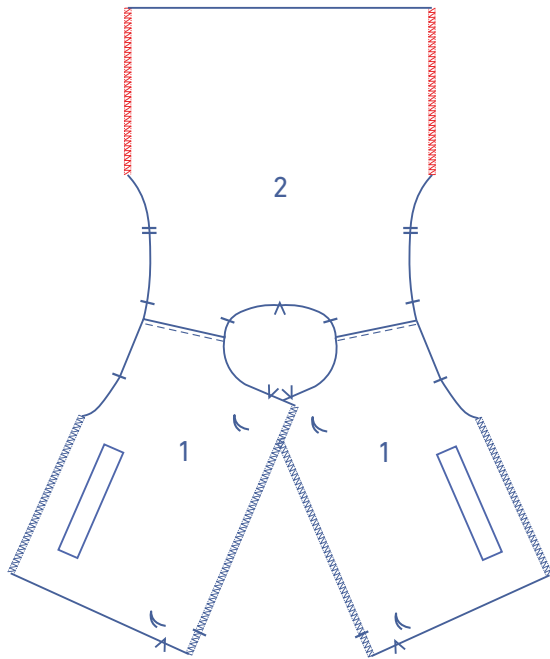

Finish the sides of the back with overlock stitching.

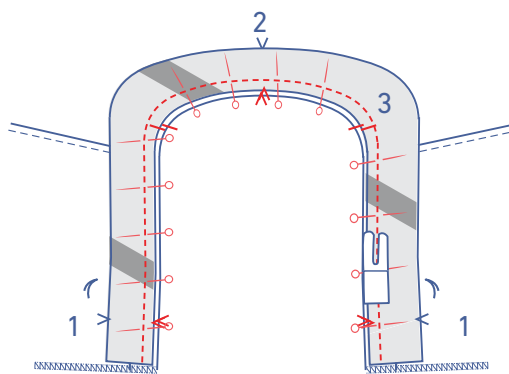

3

Pin and sew the collar (3) to the neckline, matching the notches.

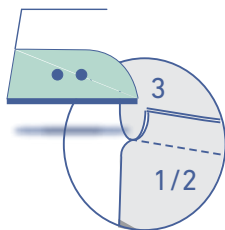

Press the seam allowance towards the collar.

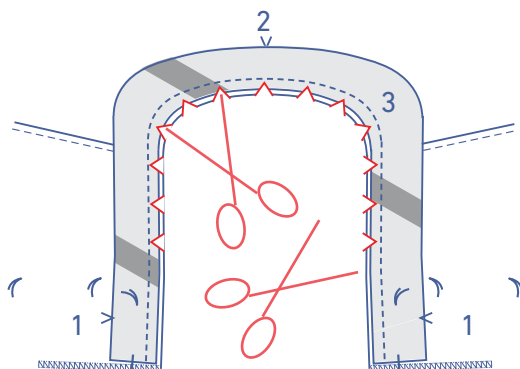

Trim the excess seam allowance to enable the collar to lie flat later.

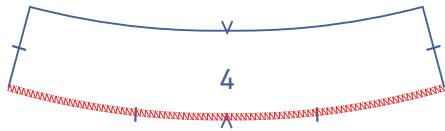

Finish the bottom of the collar facing (4) with overlock stitching.

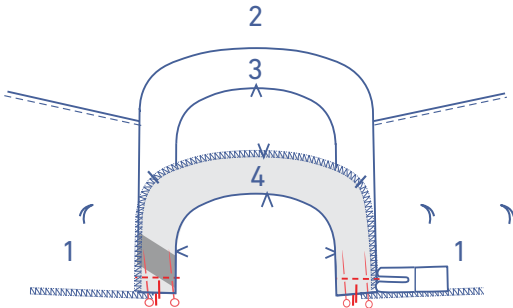

Pin and sew the short ends of the collar facing to the collar, matching the single notches.

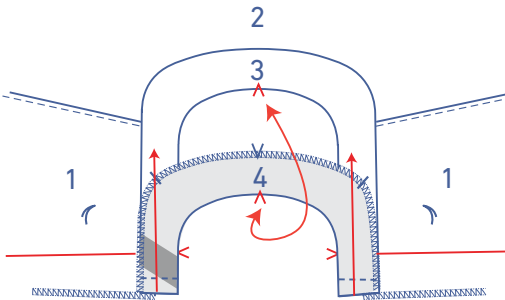

Fold the collar and facing over at the V notches so that the contours of the collar and collar facing match and the right sides of the fabric are touching.

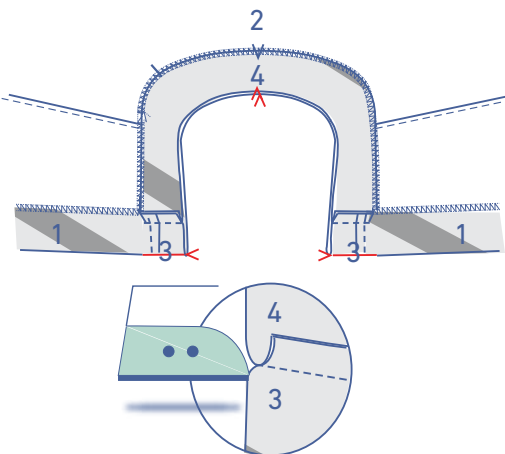

Press the seam allowance of the collar and facing towards the facing.

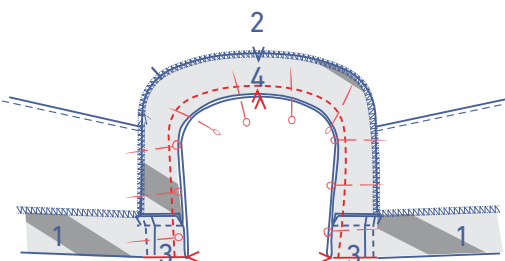

Pin and sew into place.

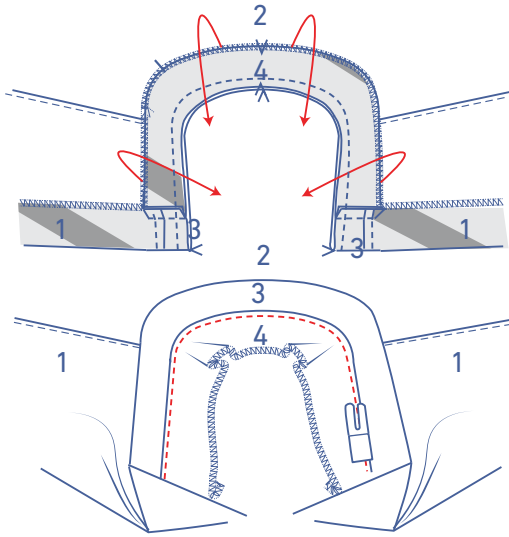

Fold the facing of the collar and seam allowance over and sew the facing to the seam allowance underneath right next to the seam.

Sew as far as you can here.

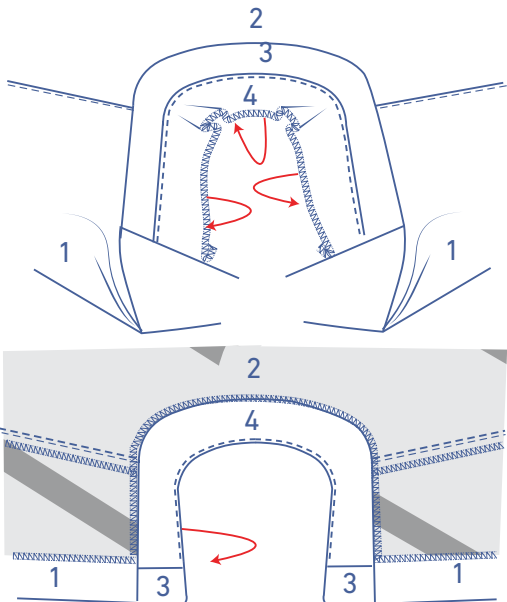

Tuck the facing neatly back under.

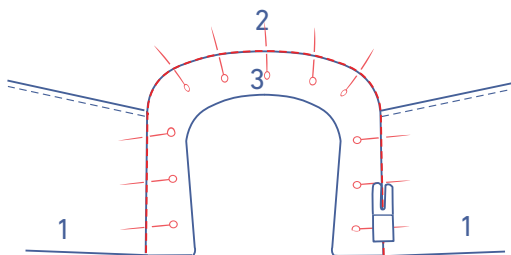

Pin the facing into place along the right side of the garment. Stitch in the ditch.

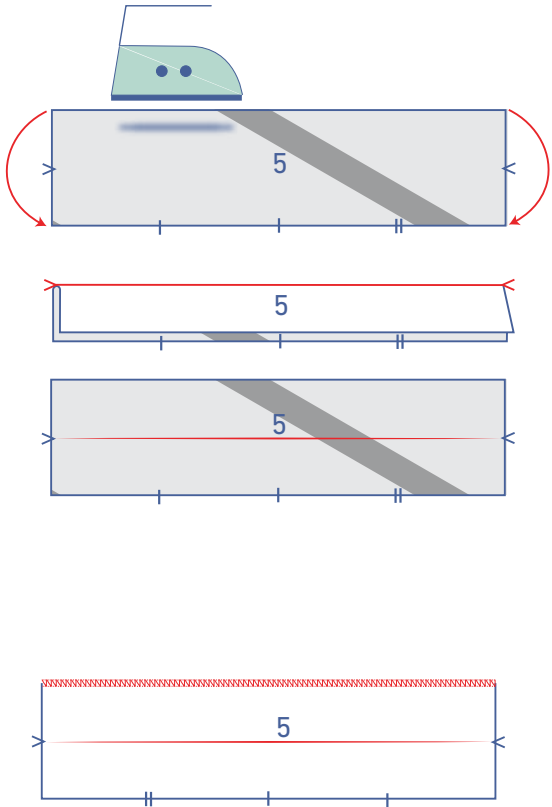

4

Press the cuff (5) in half at the V notches with the long ends together and the wrong sides of the fabric facing.

Open back out again.

Finish the unnotched long end with overlock stitching.

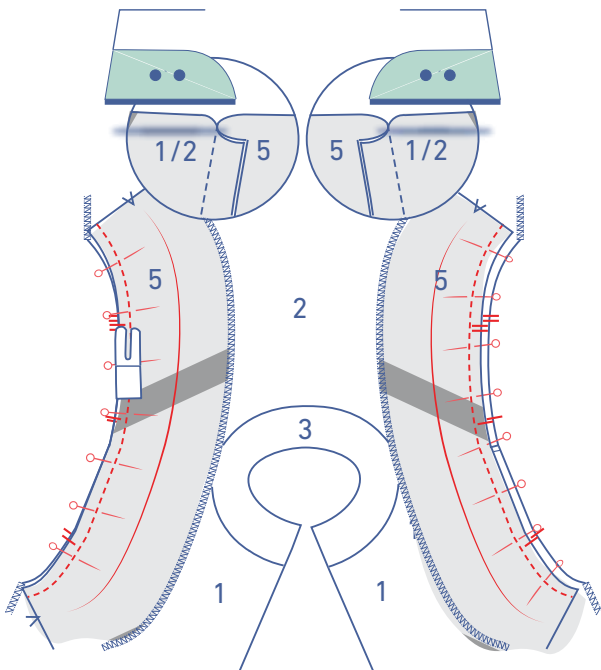

Pin and sew the notched long end to the armhole, making sure all the notches match. Press the seam allowance towards the cuff.

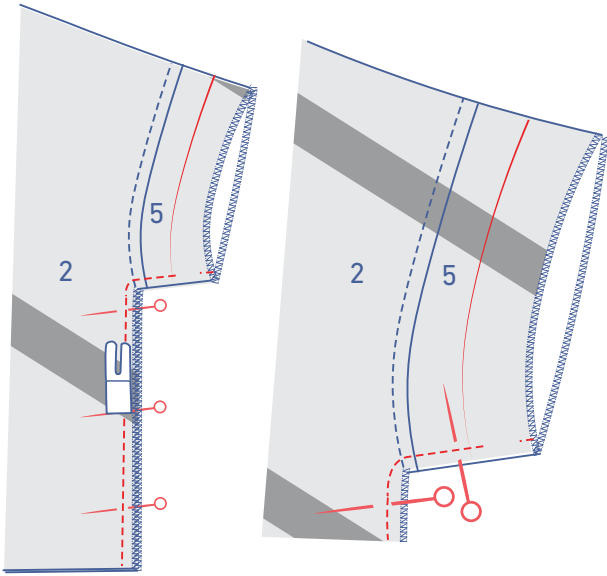

Pin and stitch the side and underarm seams (with the cuff opened out). Leave an opening where indicated to thread the elastic through later.

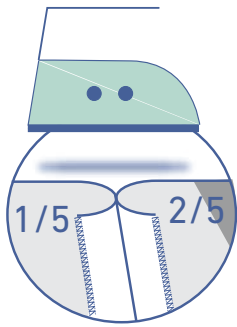

Press the seam allowances open.

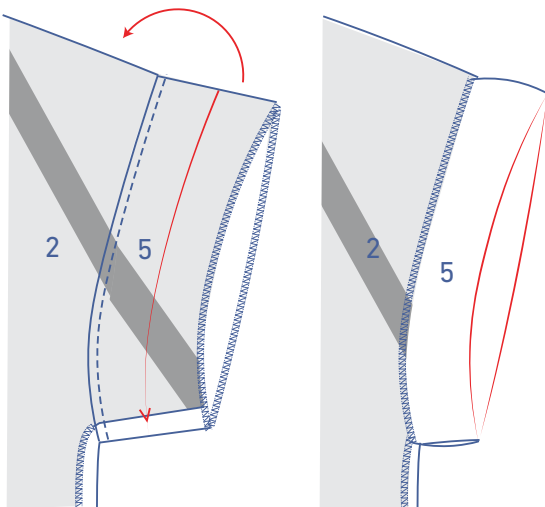

Fold the cuff over at the V notches and the fold line. Neatly press flat.

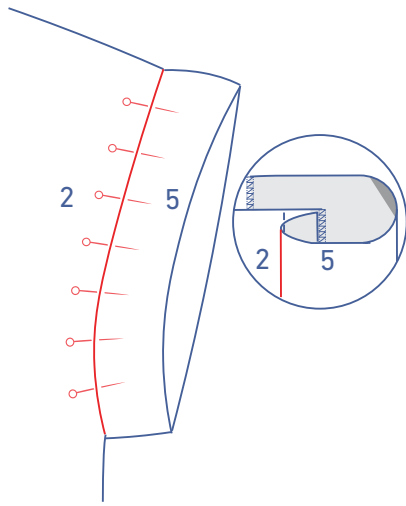

Pin the cuff into place along the right side of the garment.

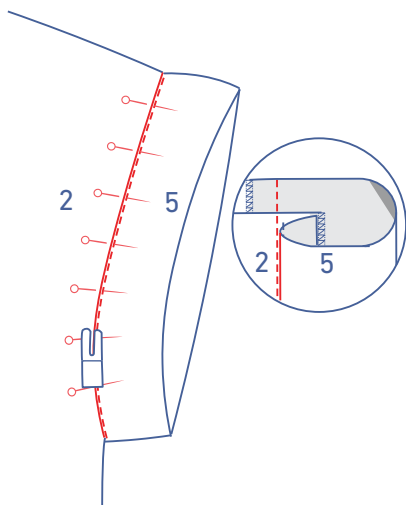

Sew the cuff into place.

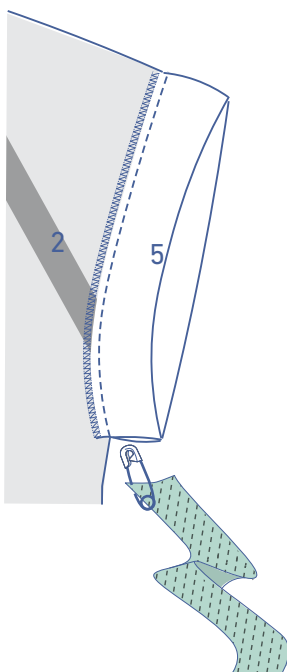

Thread the elastic through the opening of the cuff casing on the inside.

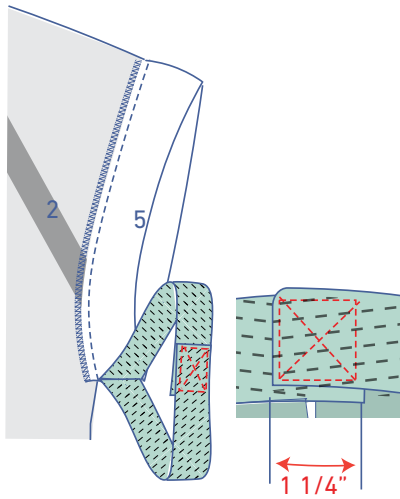

Overlap 1 1/4" of the ends and sew into place with a Box X stitch.

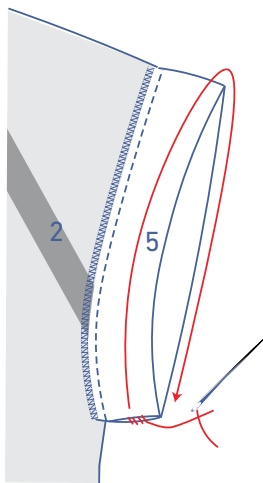

Pull the elastic all the way through the casing and hand sew the opening closed with just a few stitches.



5

Finish the top of the hem facing (9) with overlock stitching.

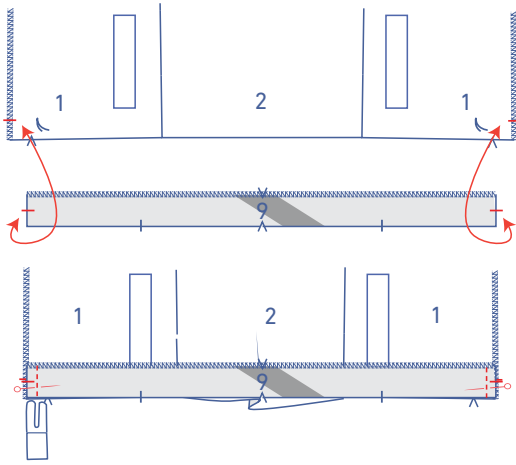

Pin and sew the short ends to the bottom of the front with the notches matching.

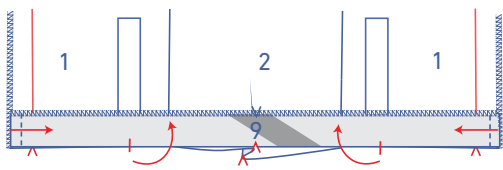

Fold the front facing over to the right side at the V notches, making sure the raw edges are level. The hem facing should now lie flat.

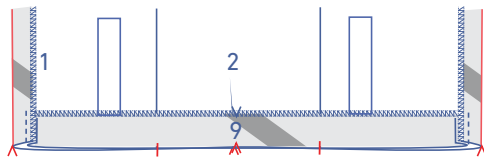

Pin and sew the facings into place.

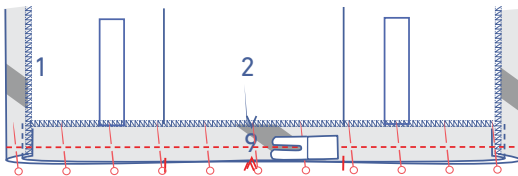

Fold the facing and seam allowance down and stitch the facing to the seam allowance underneath right next to the seam.

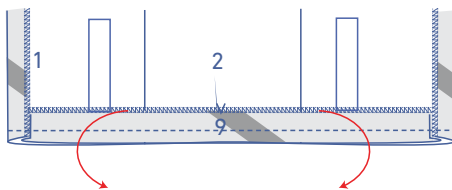

Sew as far as possible.

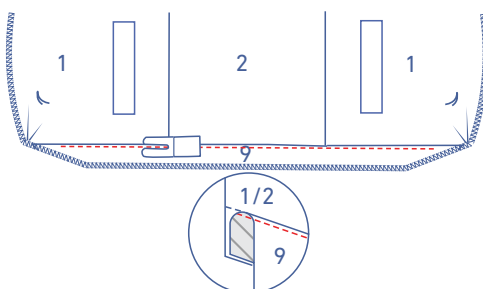

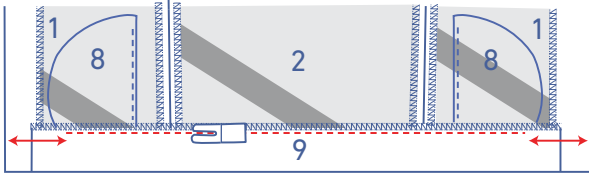

Fold the facing back up and stitch into place right next to the edge along the overlock stitching. Make sure to leave an opening on either side to thread the elastic through.

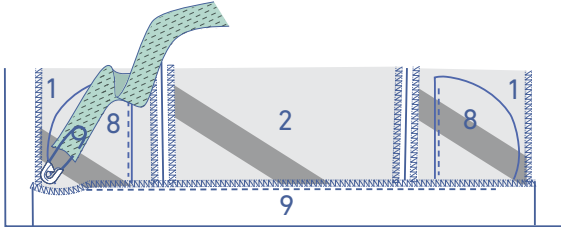

Thread the elastic through the casing via the openings.

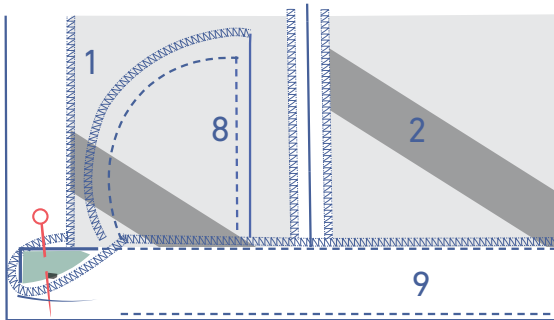

Pin the short ends of the elastic temporarily into place.

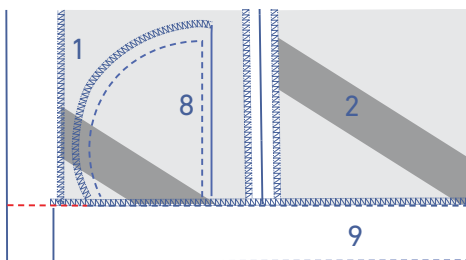
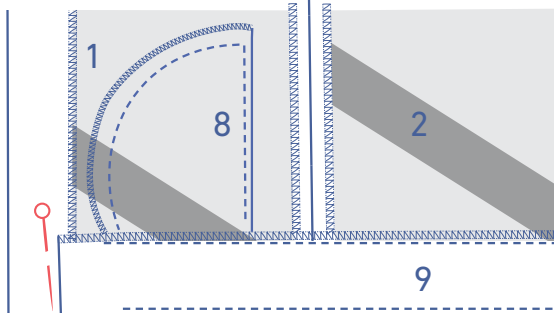
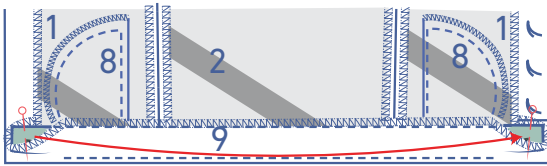

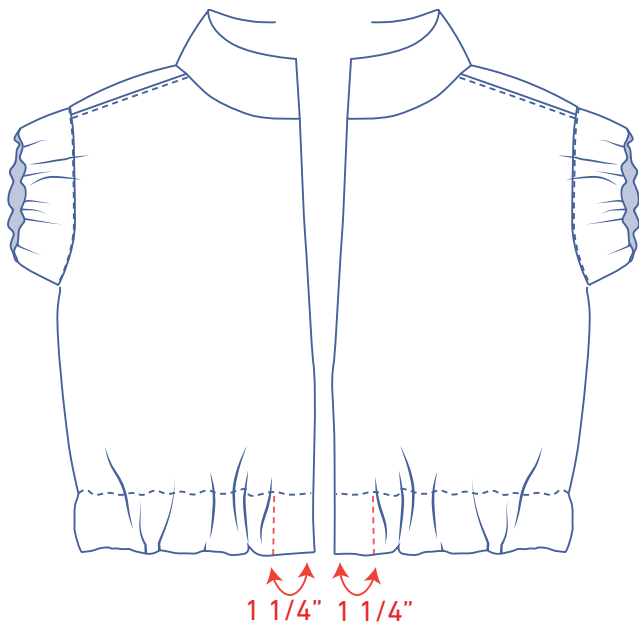

Stitch the openings closed. Topstitch at 1 1/4" making sure to catch the elastic in the hem.

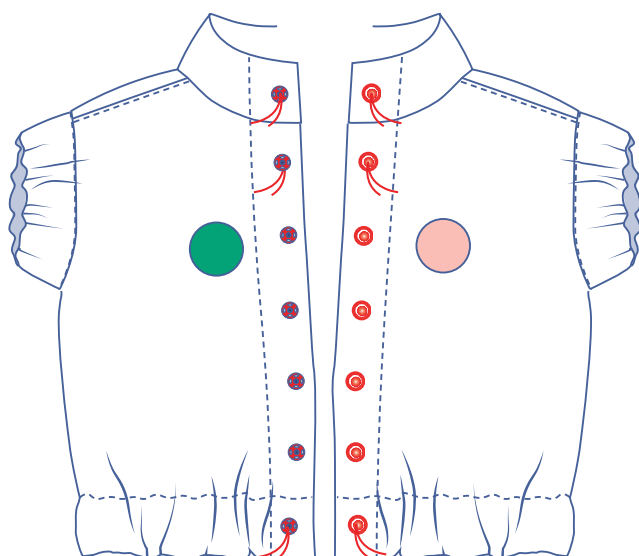

6

Attach the snaps where indicated. The positions of the top and bottom snaps have been marked on the pattern for you. Divide the distance between them evenly to determine the location of the other buttons.