

Maude by Fibre ood



Maude by Fibre Mood



0 - 28

From ankle and knee length to mini or – why not! – a blouse – the romantic Maude knows no bounds. Indulge in the A-line cut, round neckline, dropped shoulders, decorative gathers at the top and bottom of the sleeves, a curved hemline. You get discreet side seam pockets as a practical bonus. Wear this gorgeous must-have loose or belted.

Maude, just another word for options, options, and more options!

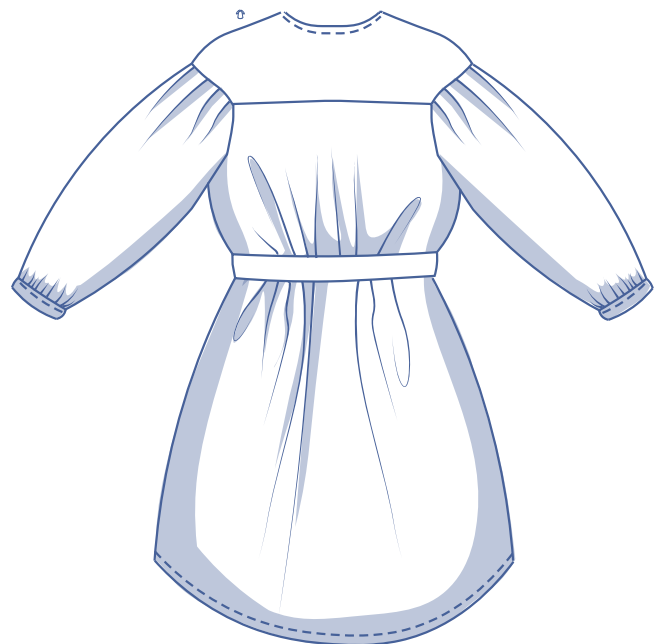
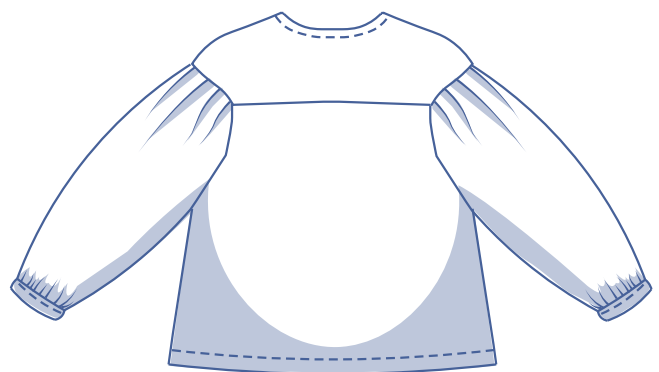
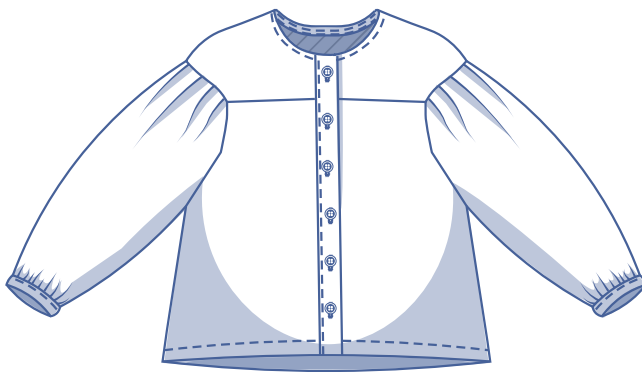

size chart (in inches)

size	0	2	4	6	8	10	12	14	16	18	20	22	24	26	28
body height	5'25"	5'38"	5'45"	5'48"	5'51"	5'54"	5'58"	5'61"	5'64"	5'64"	5'64"	5'64"	5'64"	5'64"	5'64"
B (bust)	29.9	31.5	33.1	34.6	36.2	37.8	39.4	40.9	43.3	45.7	48	50.4	52.8	55.1	57.5
H (hips)	33.9	35.4	37	38.2	39.4	40.6	41.7	42.9	45.3	47.2	49.2	51.2	53.1	55.1	57.1

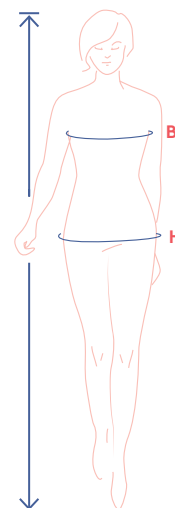

Choose your size based on your **bust measurement**. Is your hip measurement wider than what's listed in the size chart? If so, check the hip measurement in the size chart below to see whether there is enough room or whether the pattern needs to be altered. It's easy to do. When tracing the pattern, simply trace from the line of one size to the line of the other.

pattern measurements (in inches)

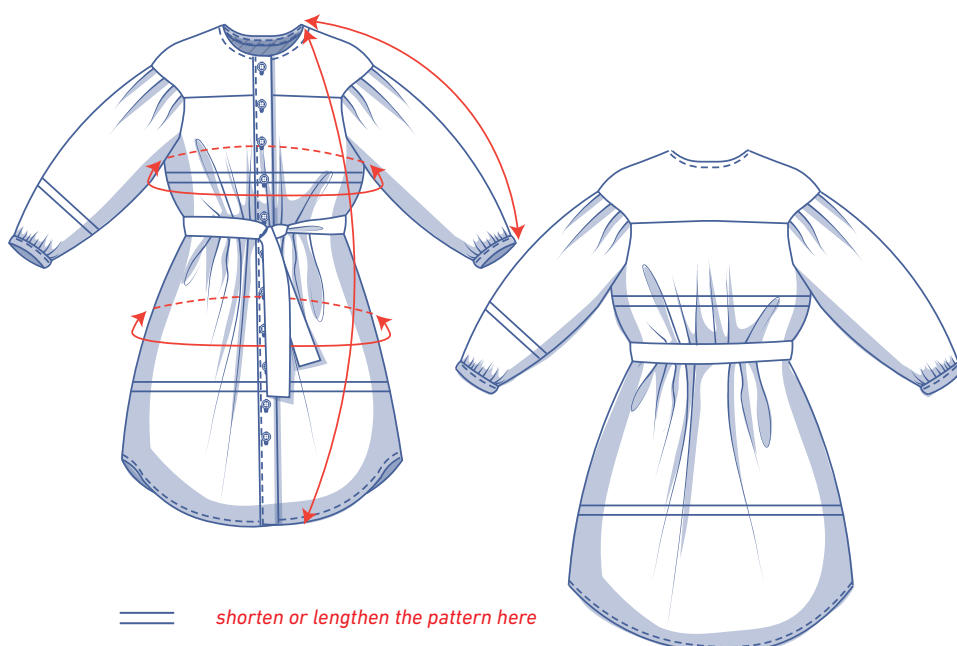

This chart's measurements are the pattern measurements based on the fabric type and serve as a reference. Ease has been added to the width measurements (in addition to the exact body measurements) for a more comfortable fit. Maude is designed to have a **relaxed fit**.

size	0	2	4	6	8	10	12	14	16	18	20	22	24	26	28
dress length	46.7	46.9	47.2	47.4	47.6	47.8	48.8	49.1	50.5	50.8	51.1	51.4	51.8	52.1	52.4
top length*	23.9	24.2	24.5	24.8	25	25.3	25.6	25.9	26.3	26.7	27.1	27.5	27.9	28.3	28.7
sleeve length**	25.6	25.8	26	26.2	26.4	26.6	26.8	26.9	27.1	27.3	27.5	27.6	27.9	28.1	28.3
bust	34.9	36.4	38	40	41.2	42.8	44.3	45.9	48.3	50.6	53	55.4	57.7	60.1	62.4
hips	46.5	48.1	49.6	51	52.5	54.1	55.6	57	59.1	61.4	63.6	65.9	68.3	70.5	72.8

* To make the Maude top, cut pattern pieces 2 and 4 until you have this total length (incl. top). Alter the length of pattern piece 7 (button placket) as well.

** Including the shoulder length and cuff.

Compare the stated lengths to the measured or desired lengths. **Lengthen** or **shorten** the dress and/or the sleeves by cutting the pattern pieces at the indicated double lines. Then either increase the distance between the cut pieces by the desired amount (to lengthen) or overlap the pieces (to shorten). Make sure that the CF and CB lines and the side seams are always straight.



IMPORTANT

Adjust the amount of fabric to be used based on these alterations.

notions



- Thread
- Iron-on interfacing: max. 1 $\frac{3}{8}$ yd
- Buttons (\emptyset 7/16"): see table
- Fabric: see table

buttons	0	2	4	6	8	10	12	14	16	18	20	22	24	26	28
	11	11	11	11	11	11	11	11	12	12	12	12	12	12	12

fabric use top		0	2	4	6	8	10	12	14	16	18	20	22	24	26	28
fabric width 43"	yd	2	2	2 $\frac{1}{8}$	2 $\frac{1}{8}$	2 $\frac{1}{8}$	2 $\frac{1}{4}$	2 $\frac{1}{4}$	2 $\frac{5}{8}$	2 $\frac{3}{4}$	2 $\frac{3}{4}$	2 $\frac{3}{4}$	3	3	3	3
fabric width 55"	yd	1 $\frac{1}{2}$	1 $\frac{1}{2}$	1 $\frac{1}{2}$	1 $\frac{5}{8}$	1 $\frac{5}{8}$	1 $\frac{5}{8}$	1 $\frac{3}{4}$	1 $\frac{3}{4}$	1 $\frac{7}{8}$	2 $\frac{1}{8}$	2 $\frac{1}{8}$	2 $\frac{1}{4}$	2 $\frac{1}{4}$	2 $\frac{1}{4}$	2 $\frac{1}{4}$

fabric use dress		0	2	4	6	8	10	12	14	16	18	20	22	24	26	28
fabric width 43"	yd	3 $\frac{1}{2}$	3 $\frac{1}{2}$	3 $\frac{1}{2}$	3 $\frac{1}{2}$	3 $\frac{3}{4}$	3 $\frac{3}{4}$	3 $\frac{3}{4}$	4 $\frac{1}{4}$	4 $\frac{1}{4}$	4 $\frac{1}{2}$	4 $\frac{1}{2}$	4 $\frac{3}{4}$	5	5	-
fabric width 55"	yd	2 $\frac{1}{2}$	2 $\frac{1}{2}$	2 $\frac{1}{2}$	2 $\frac{3}{4}$	3	3 $\frac{1}{4}$	3 $\frac{1}{4}$	3 $\frac{1}{4}$	3 $\frac{3}{8}$	3 $\frac{1}{2}$	3 $\frac{1}{2}$	3 $\frac{1}{2}$	3 $\frac{3}{4}$	3 $\frac{3}{4}$	3 $\frac{3}{4}$

The corresponding fabric layout can be found on page 6 of these sewing instructions.

* Fabric use is not specified for size 28 because pattern piece 4 is too wide and long to fit on the given fabric width.

fabric advice



When it comes to selecting a fabric for Maude, you have a wide selection to choose from. Lyocell, poplin, chambray, linen, viscose (crepe), muslin, broderie anglaise, and baby wale corduroy are just a few. Even leather(ette) or thin, padded fabrics are an option.

Proud to be #Sewista

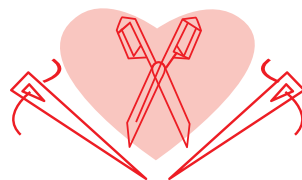

pattern pieces & seam allowances (in inches)

To sew the garment as described in the instructions, draw the illustrated seam allowances around the paper pattern pieces before cutting them out. If you are using a PDF pattern, the pattern can be printed with or without seam allowance. To find out more, watch the [video](#).

1. top piece front: 2x
2. front: 2x
3. top piece back: 1x on fabric fold
4. back: 1x on fabric fold
5. sleeve: 2x
6. cuff: 2x
7. button placket: 2x
8. bias tape neck: 1x
9. pocket: 4x
10. belt: 2x

IMPORTANT

To make the top, shorten pattern pieces 2 and 4 to your preferred length (we give a measurements guide on page 3) and add 1.5 cm of hem allowance. Remember to alter the length of pattern piece 7 as well. The top version does not require pattern pieces 9 and 10.

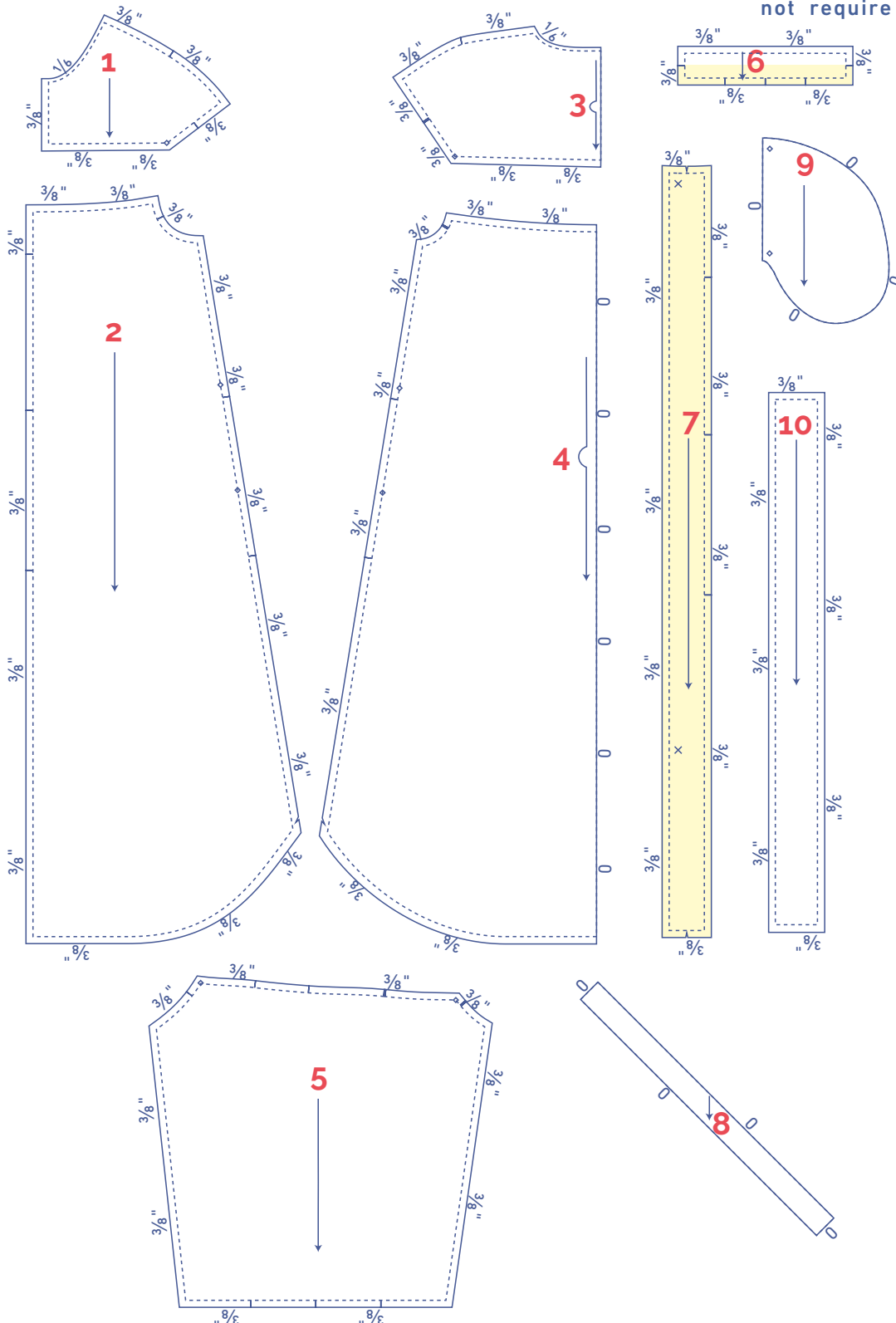

IMPORTANT
The pieces highlighted in light yellow have iron-on interfacing attached to the wrong side.

?	material type
□	fabric
■	iron-on interfacing

fabric layout – solid fabrics
fabric width 43"

0 - 12

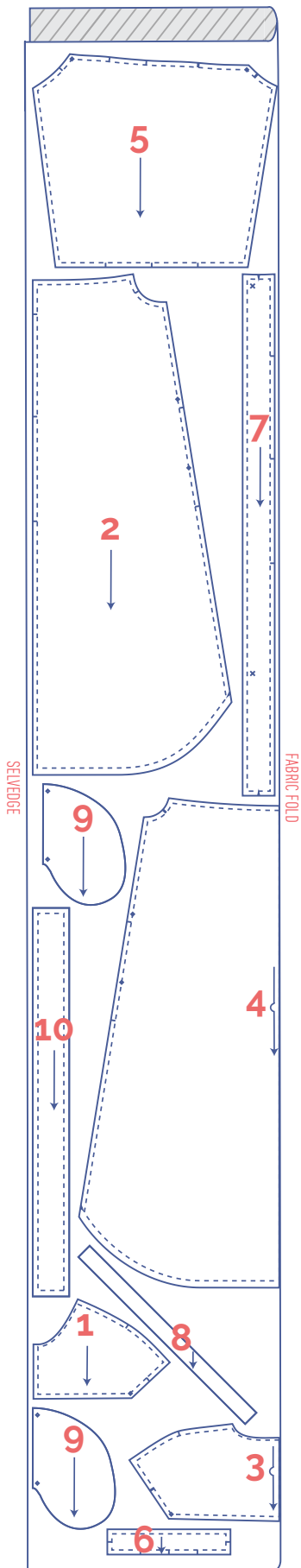

14 - 22

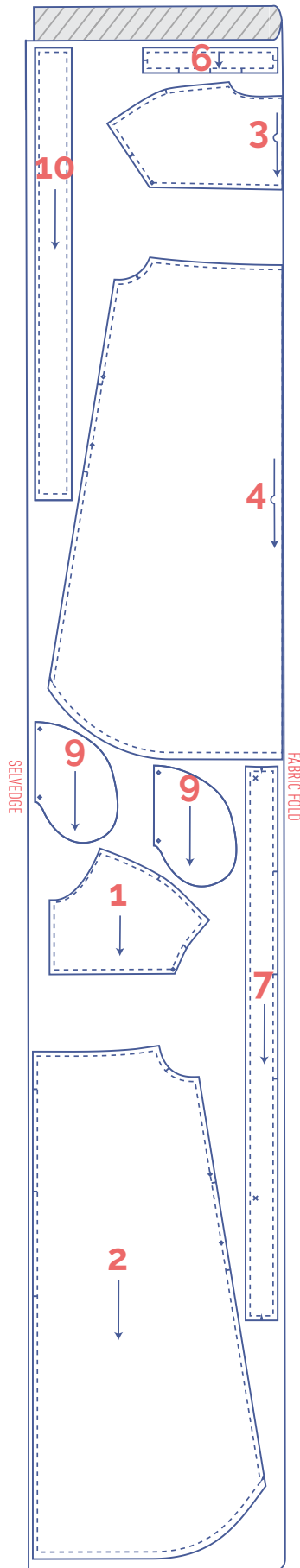

+

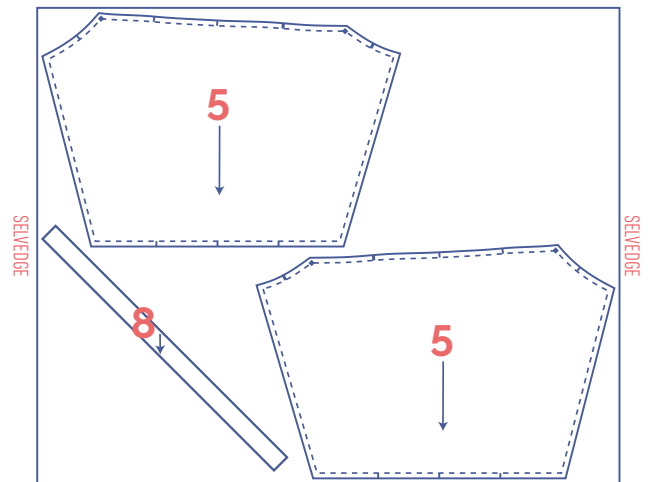

IMPORTANT

You only need pattern piece 8 once.

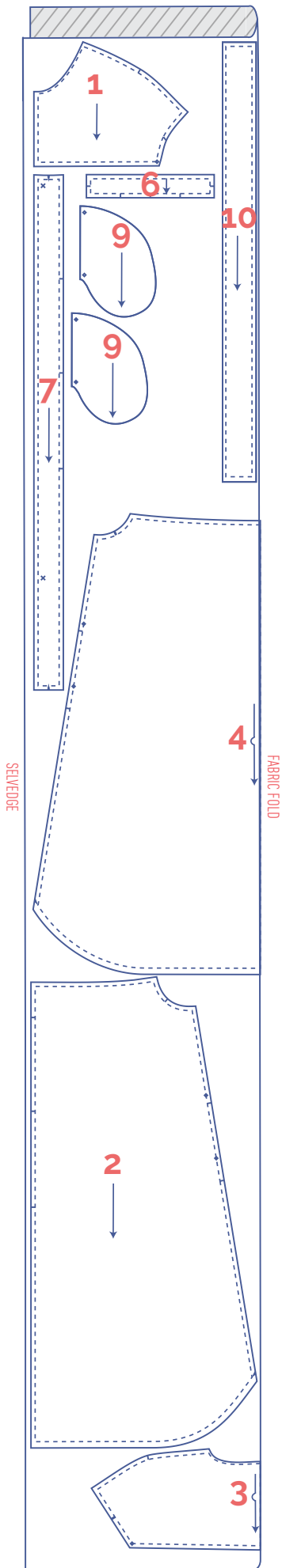

+

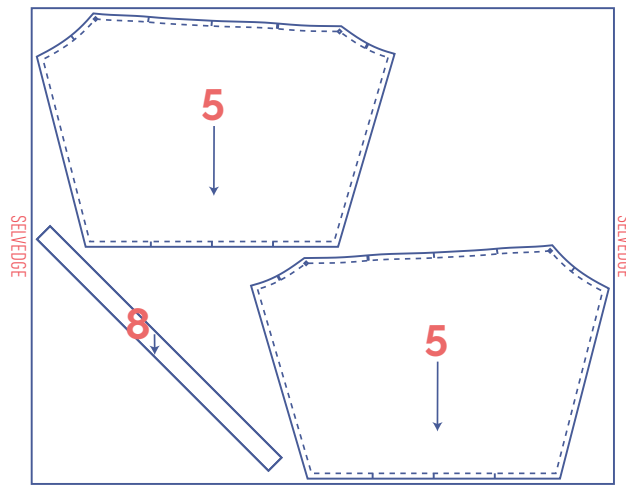

IMPORTANT

Be sure to cut mirror images of piece 5.

marking pattern pieces



notch the pattern paper and fabric at the following points



single notch



double notch



V notch



mark the following points using marking thread



centre point



button

fabric layout – solid fabrics
fabric width 55"

0 - 6

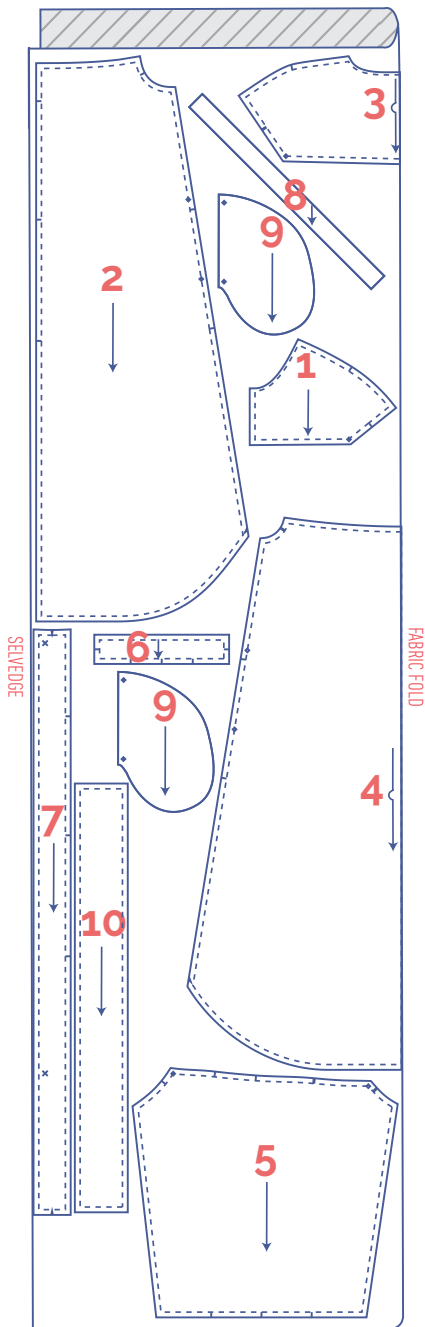

IMPORTANT

You only need pattern piece 8 once.

8 - 24

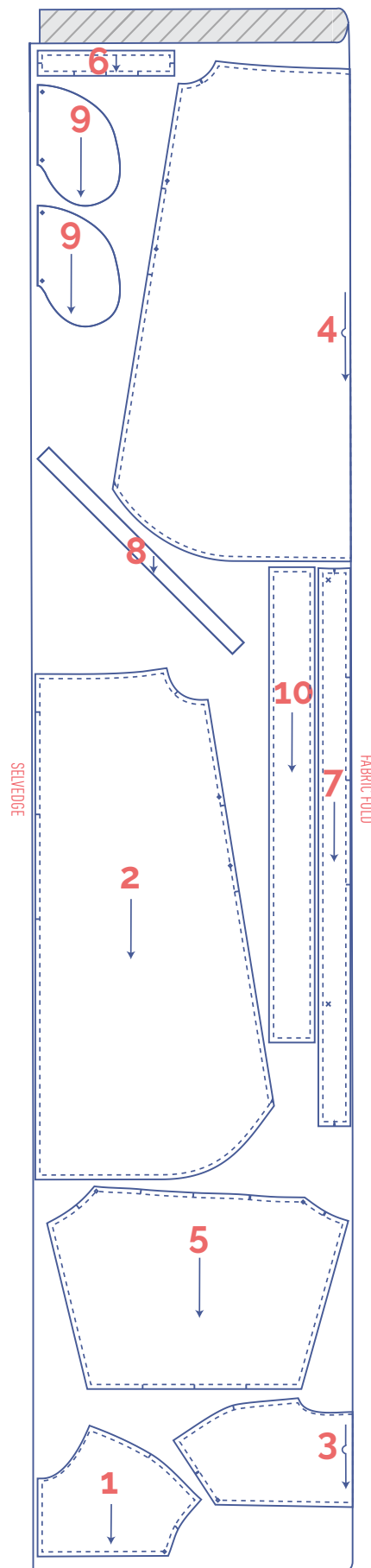

IMPORTANT

You only need pattern piece 8 once.

26 - 28

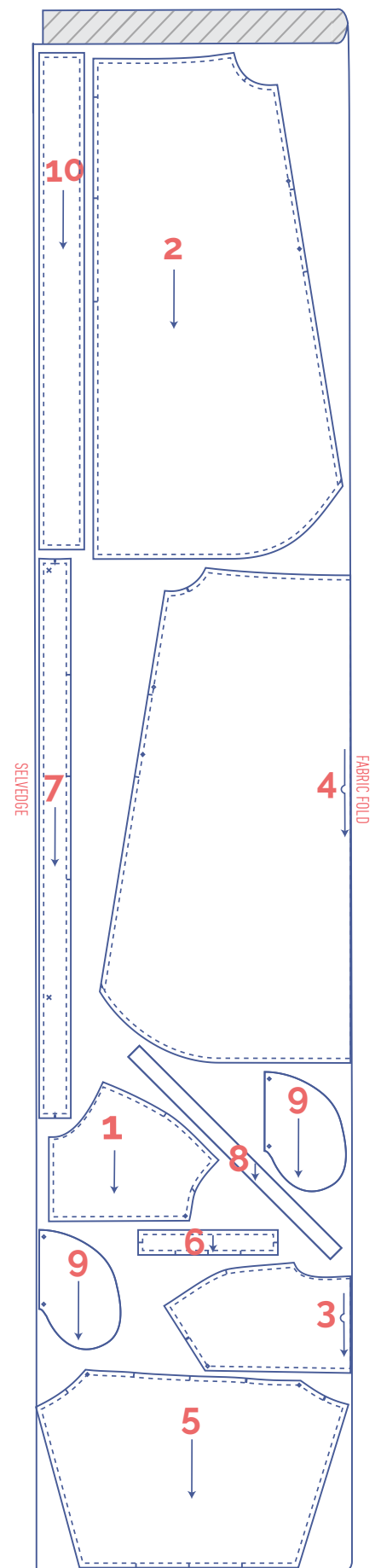





sewing instructions



The method used to finish the seams depends on the fabric used. The pieces are always sewn together with the right sides of the fabric facing, unless stated otherwise.



F	front
B	back
CF	centre front
CB	centre back
RF	right front 
LF	left front 
	right side
	wrong side
	iron-on interfacing

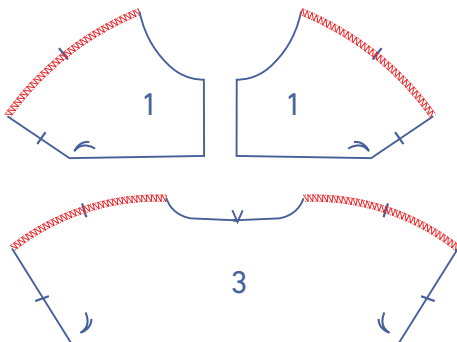
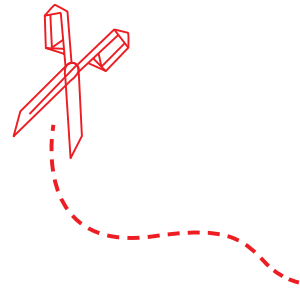

1

Finish the raw edges of the top piece front (1) and top piece back (3) with overlock stitching where indicated.

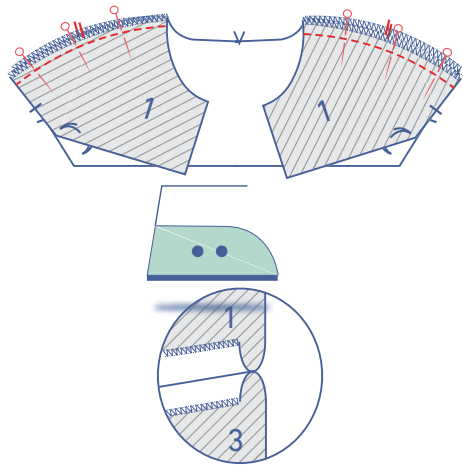

Pin and sew the shoulder seams together and press the seam allowance open.

2

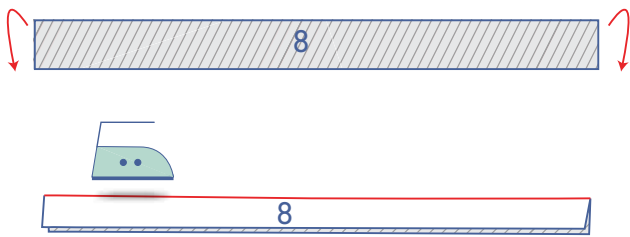

Fold the bias tape neck (8) in half with the long ends touching and the wrong sides of the bias tape facing.

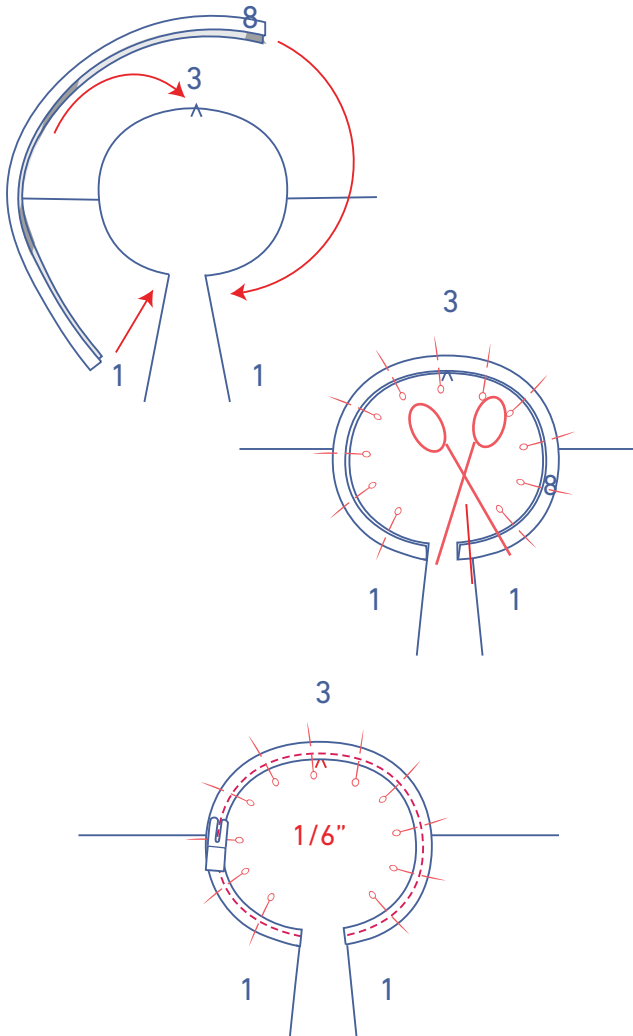

Pin the raw edges of the bias tape to the right side of the neckline. The raw edges of the bias tape should line up evenly with the raw edge of the CF.

Snip off any excess bias tape. Note: the length of the bias tape may differ depending on the fabric used.

Sew the bias tape into place at 1/6" from the neckline.

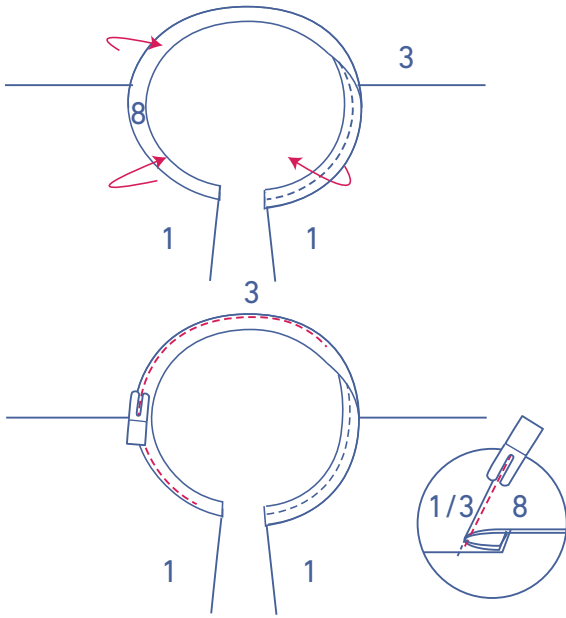

Fold the bias tape over and sew to the seam allowance underneath, right next to the seam.

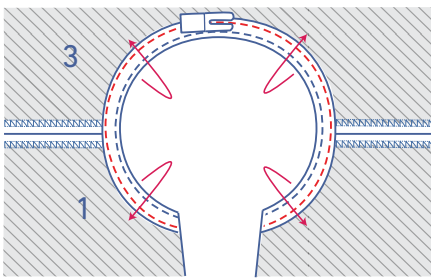

Now, fold the bias tape over towards the wrong side and sew into place right next to the edge.

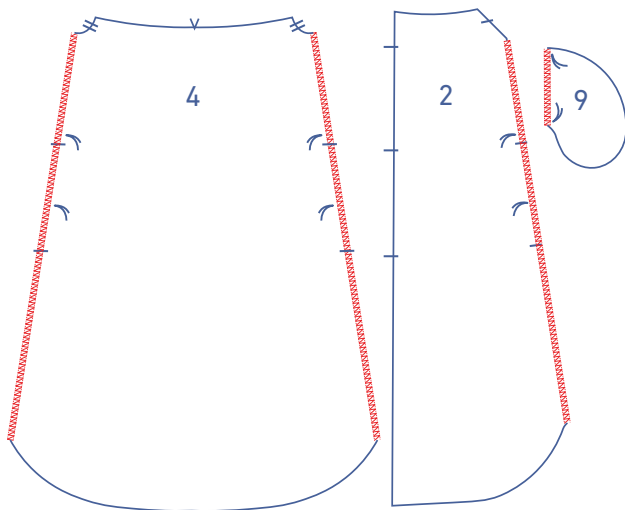

3

Finish the raw edges of the front (2), back (4) and pocket (9) with overlock stitching where indicated.

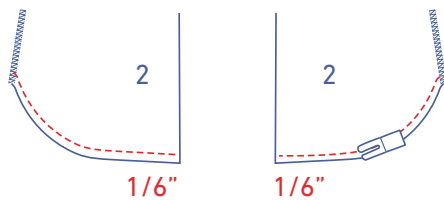

Finish the hem of the front and back as follows: sew at 1/6" from the raw edge.

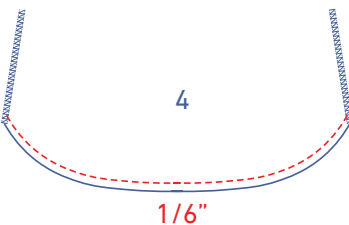

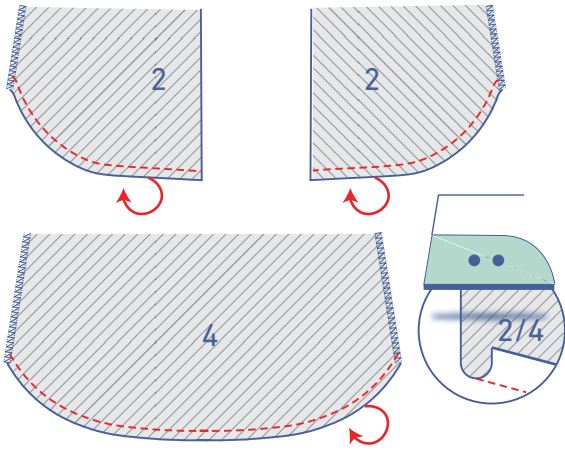

Then, press the edge over at the stitching.

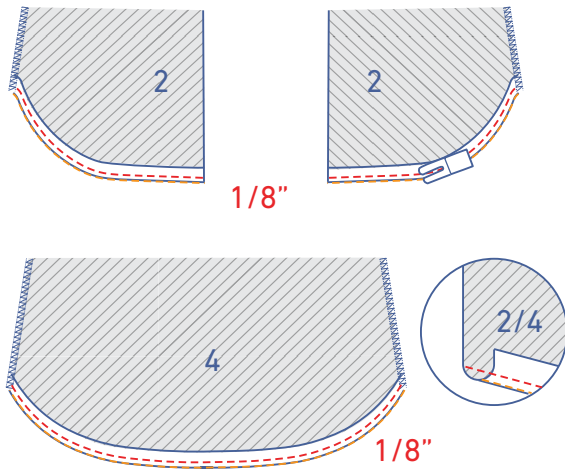

Sew the pressed seam allowance into place at 1/8" from the edge.

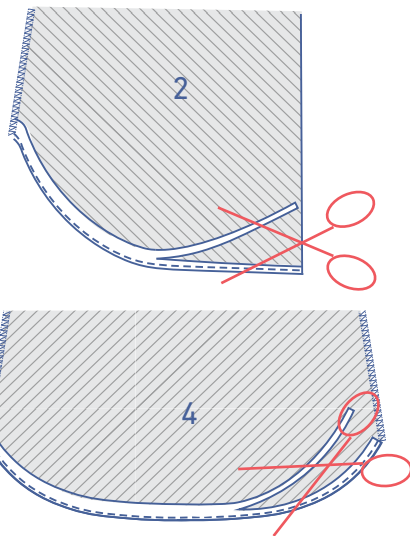

Trim any excess seam off (appliqué scissors are useful here if you have them).

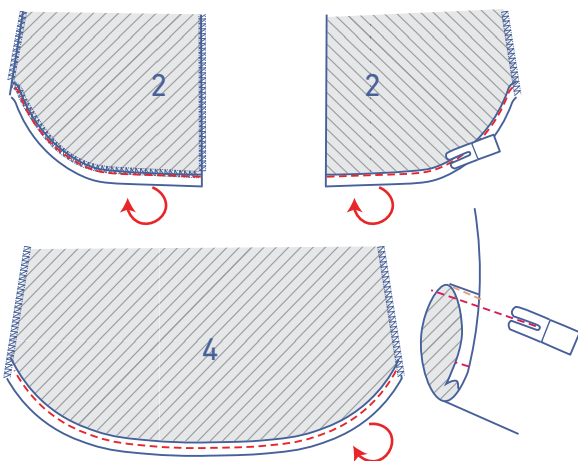

Now, for the last time, fold the edge over towards the wrong side and sew into place.

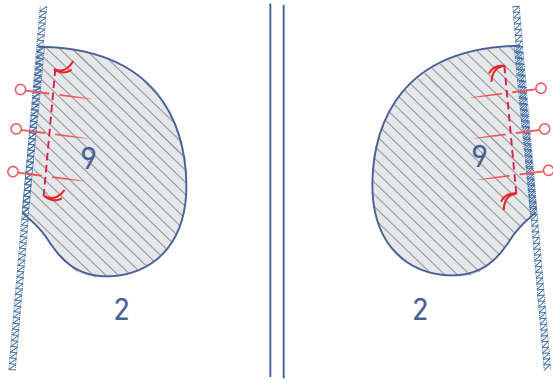

4

Pin the straight ends of two of the four pocket pieces to each side of the front, matching the marking threads. Stitch into place between the marking threads.

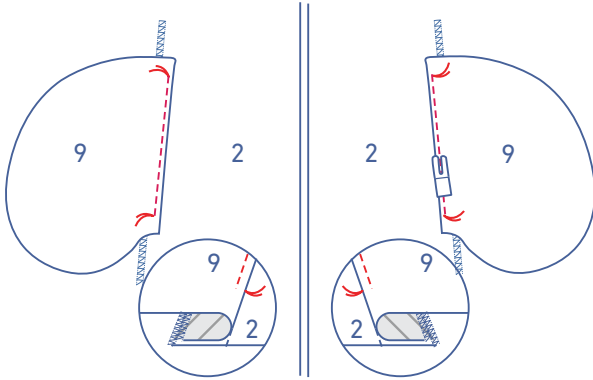

Fold the pocket and seam allowance over and sew the pocket to the seam allowance underneath.

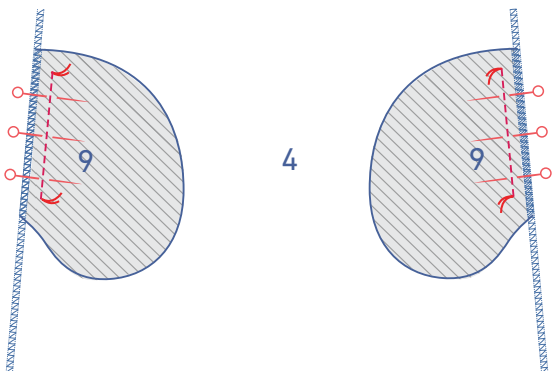

Pin the straight ends of the remaining pocket pieces to the sides of the back, matching the marking threads. Stitch into place between the marking threads.

5

Pin and sew the front to the yoke front as shown.

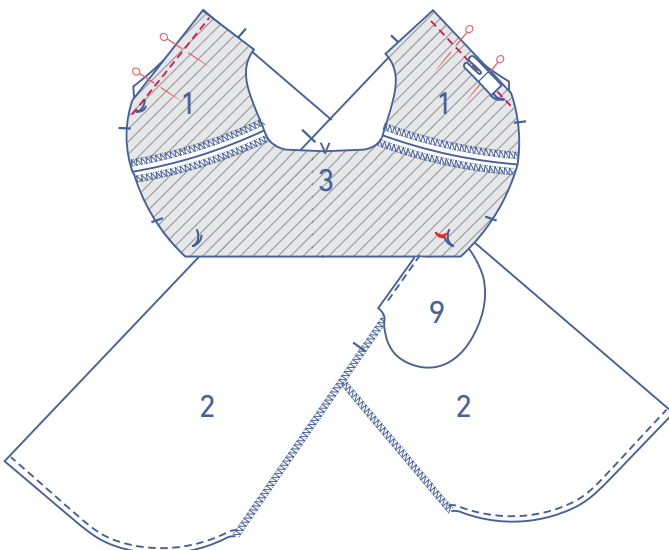

Pin and sew the back to the yoke back.

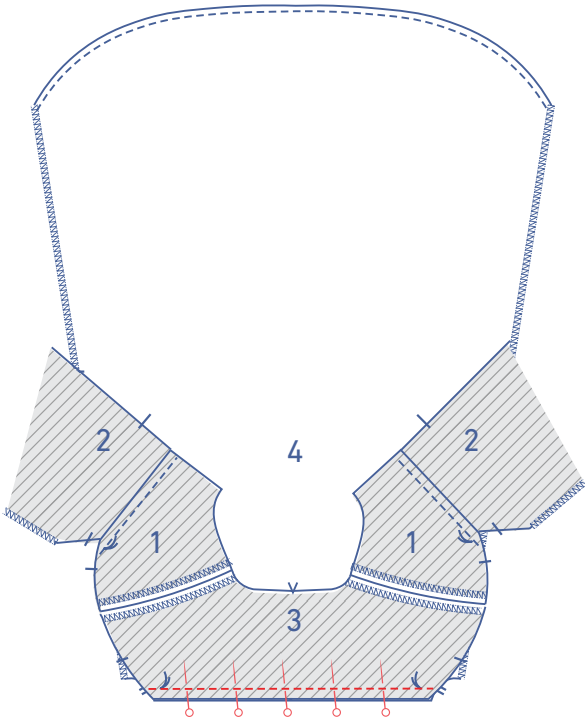

Finish the raw edges with overlock stitching and press the seam allowance towards the front/back.

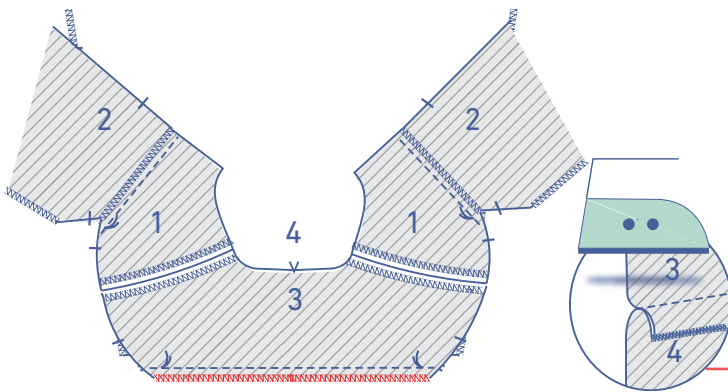
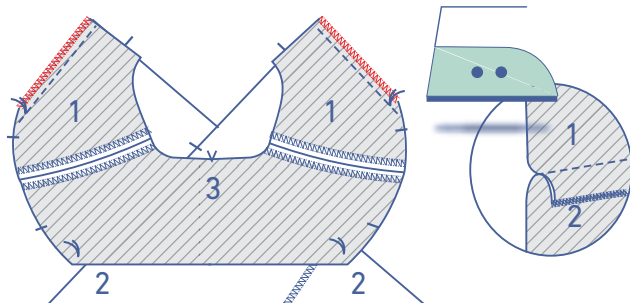

6

Finish the sleeve sides (5) with overlock stitching.

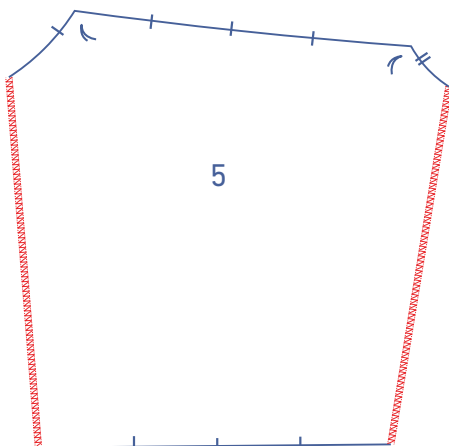

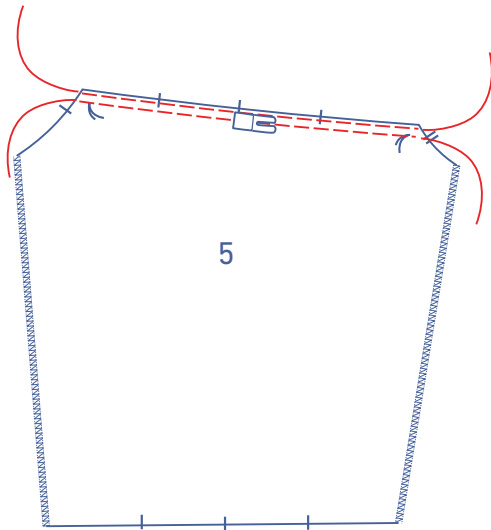

Sew two parallel lines of stitching along the top of the sleeve between the marking threads, using a long stitch length at a low thread tension. Leave a length of thread at the start and end of the stitching.

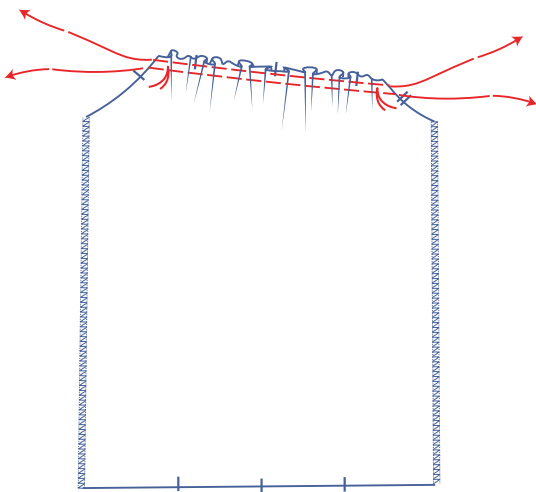

Gently tug the ends of the threads to gather the fabric.

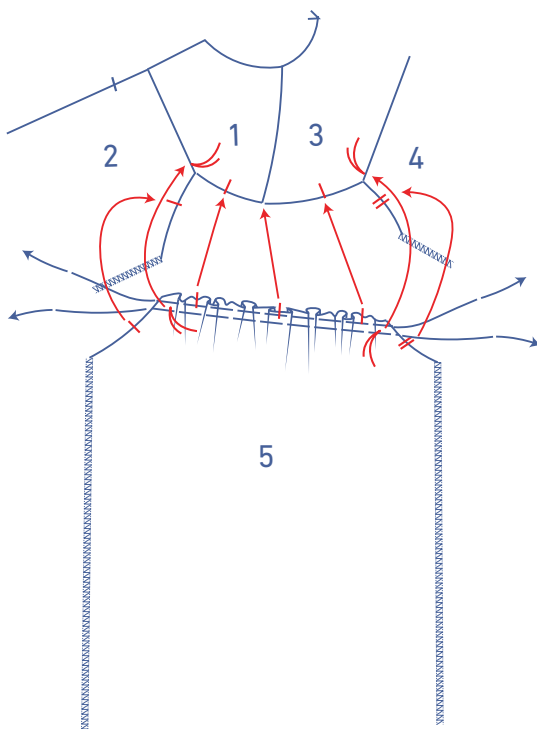

Distribute the gathers so that the sleeve markings match those of the front and back.

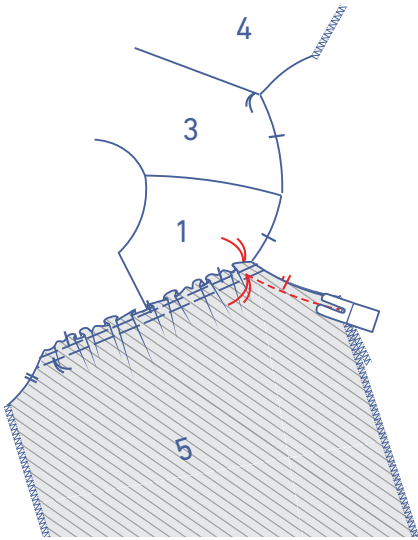

Pin the sleeve to the front. Sew right up to the indicated marking thread and leave the needle in the fabric there.

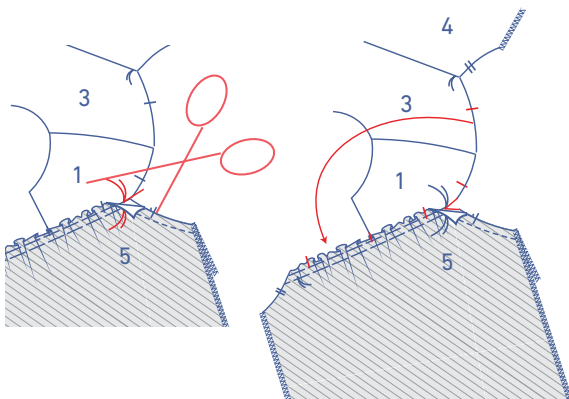

Raise the presser foot, fold the seam allowance of the sleeve out of the way, and snip into the seam allowance of the yoke until just before the marking thread. Turn the garment and lower the presser foot back down.

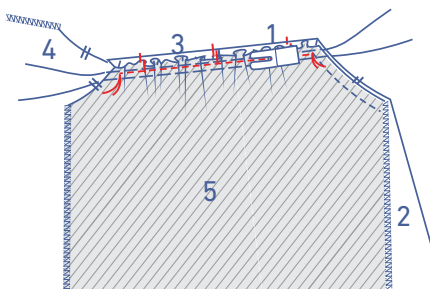

Pin the top of the sleeve to the yoke up to the next marking thread and sew into place. Leave the needle in the fabric again.

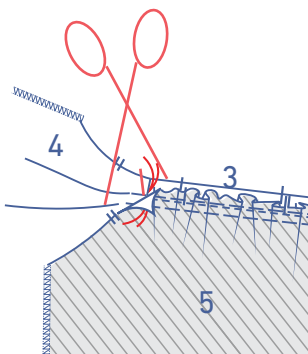

Raise the presser foot, fold the seam allowance of the sleeve out of the way and snip into the seam allowance of the yoke until just before the marking thread. Turn the garment and lower the presser foot back down.

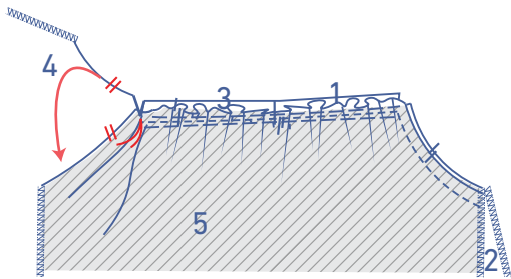

Pin and sew the rest of the sleeve to the back.

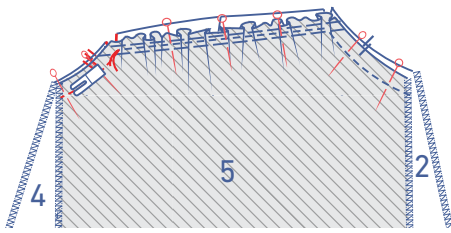

Then remove the gathering threads.

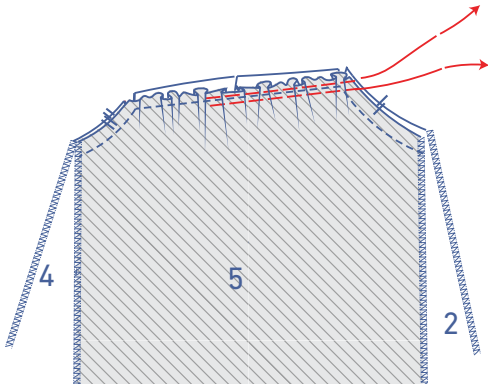

Finish the raw edges with overlock stitching.

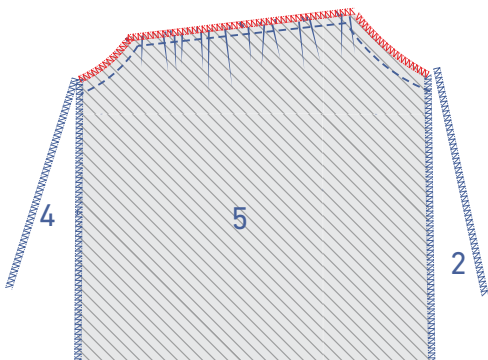

7

Pin the underarm and side seams together and sew. Sew up to the marking threads that mark the top of the pocket opening. Now, sew from the next marking thread down to the hem. Press the seam allowance open.

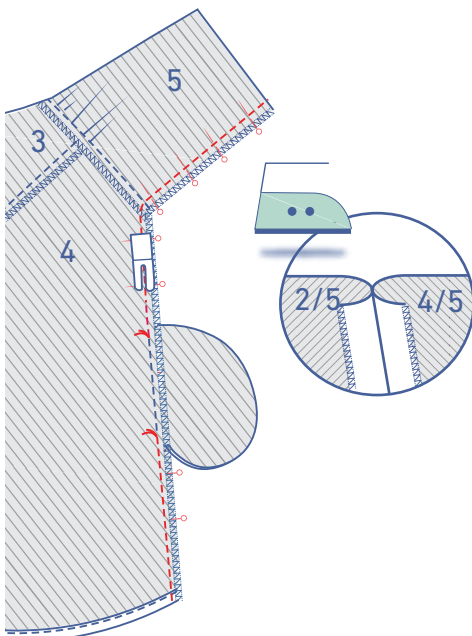

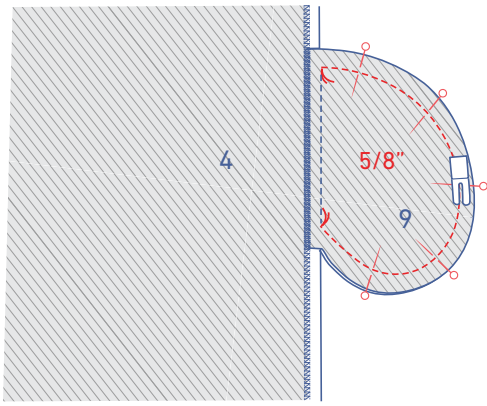

Pin and sew the contours of the pocket pieces together at 5/8" from the raw edge.

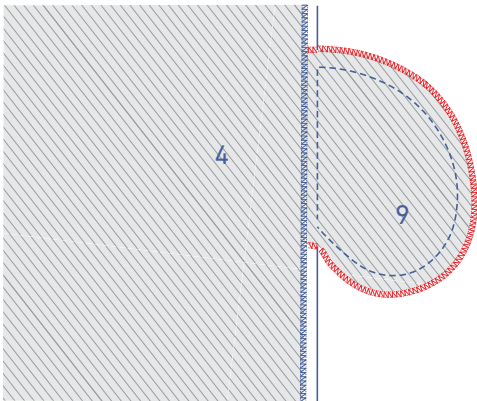

Finish the raw edges with overlock stitching.

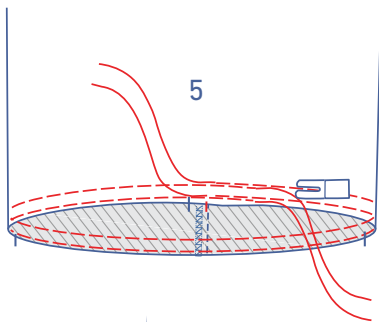

8

Sew two lines of parallel stitching at the bottom of the sleeve, using a long stitch length at a low thread tension. Leave a length of thread at the start and end of the stitching.

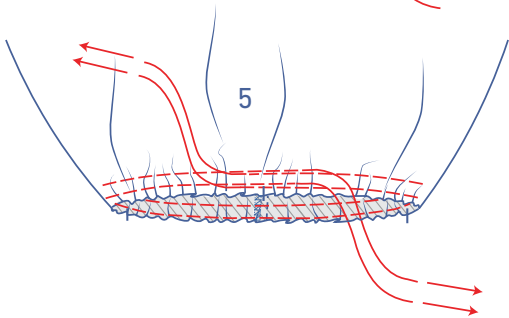

Then, gently tug the gathering threads to gather the fabric.



Press the cuff (6) in half with the long ends together and the wrong sides of the fabric facing to create a fold line.



Open back out.



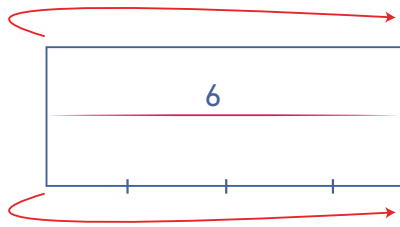

Fold the cuff in half so that the short ends are matching, and the right sides of the fabric are facing.

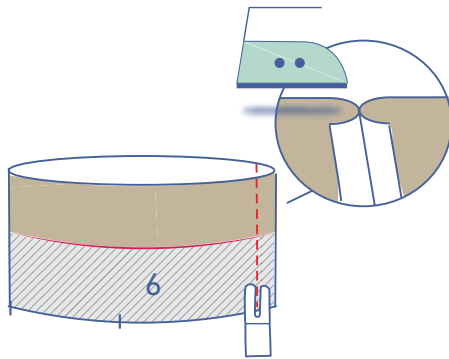

Pin and sew the short ends together. Press the seam allowance open.

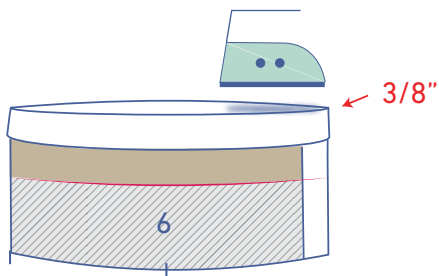

Press 3/8" of the long unnotched end of the cuff towards the wrong side.

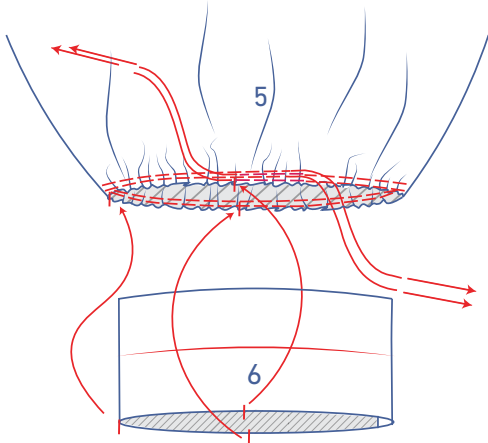

Gently tug the ends of the gathering threads until the sleeve notches match the cuff notches.

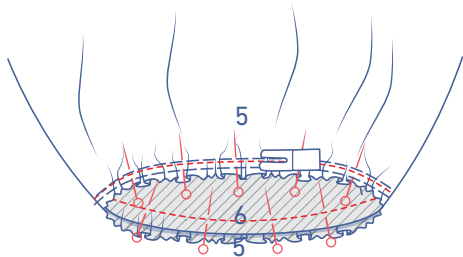

Slide the sleeve over the cuff, pinning the notched end of the cuff to the bottom of the sleeve along the inside (= the wrong side). Sew into place.

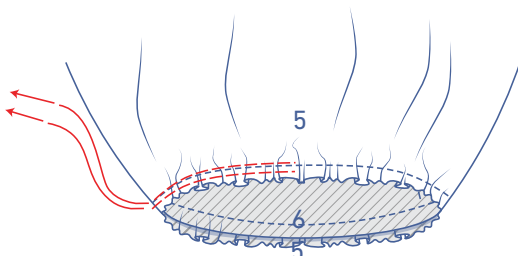

Remove the gathering threads.

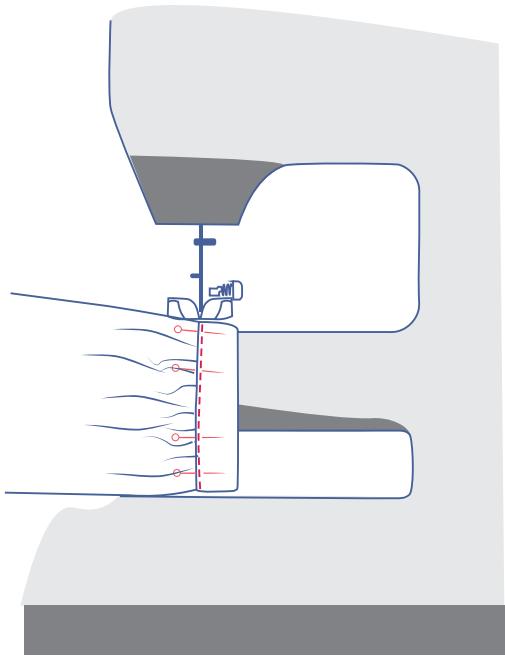

Fold the cuff over to the right side of the sleeve and place the pressed edge directly over the previous stitching. Edgestitch into place.

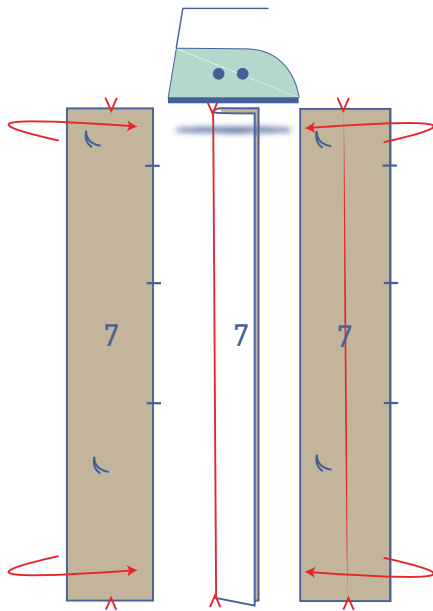

9

Press the button placket (7) in half with the long ends together and the wrong sides of the fabric facing to create a fold line. Open back out.

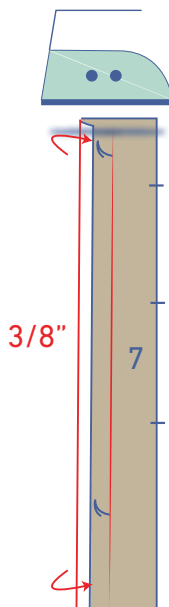

Press 3/8" of the unnotched end towards the wrong side.

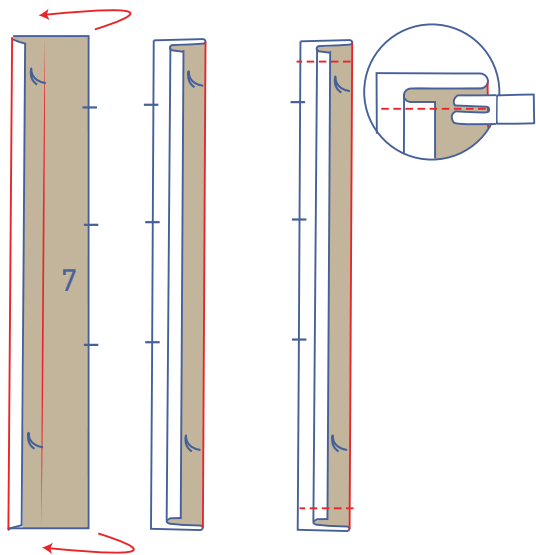

Fold the button placket in half along the pressed fold line so that the right sides of the fabric are touching. Sew the short ends closed.

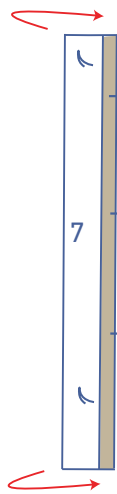

Turn the button placket the right way out.

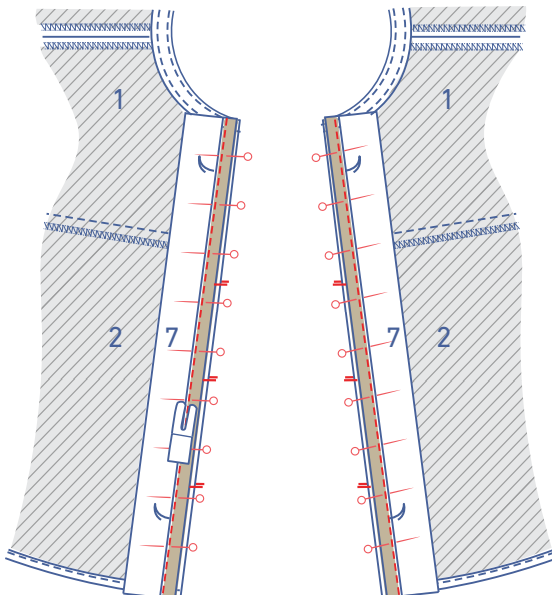

Pin the notched end of the button placket to the CF along the wrong side of the garment. The finished top of the button placket should line up evenly with the finished neckline, and the finished bottom should match the finished hem. All notches should match. Sew into place.

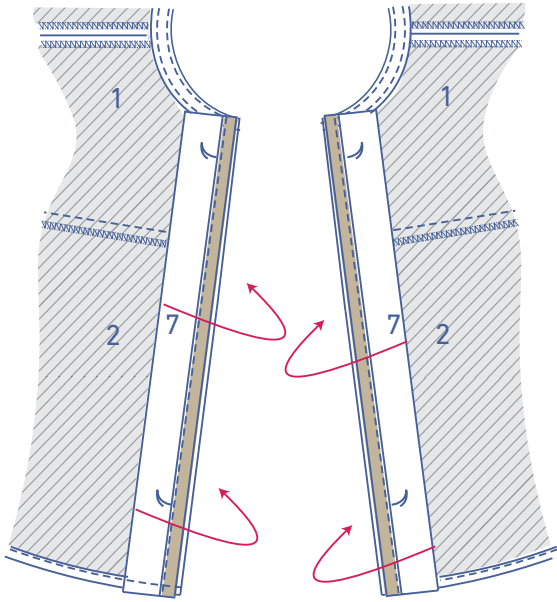

Turn the button placket over onto the right side of the garment.

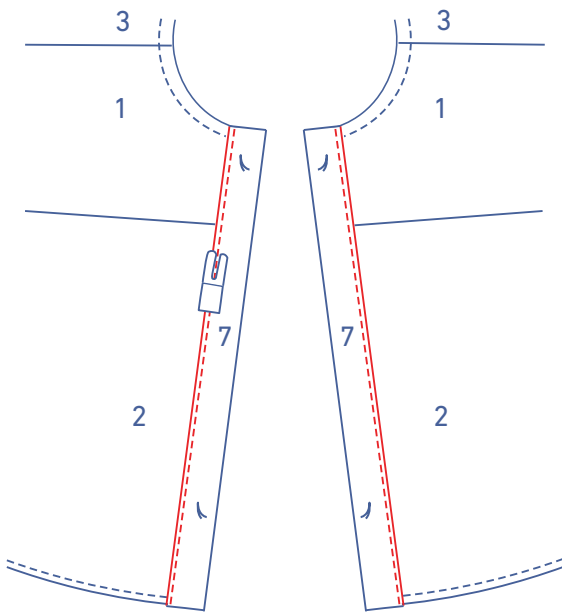

Place the fold line directly over the stitching and edgestitch into place.

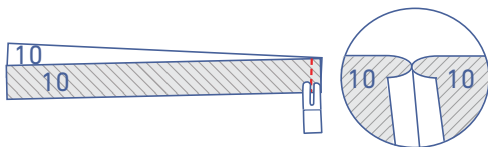

10

Pin and sew the CB seams of the belt pieces (10) together. Press the seam allowance open.

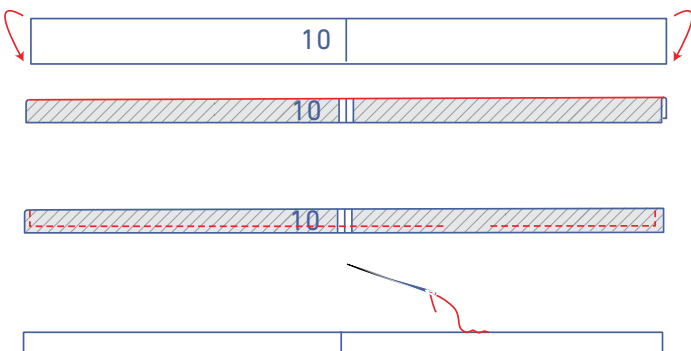

First, open the belt all the way out. Then fold it in half along the long ends and the right sides of the fabric facing.

Sew the ends indicated, but leave an opening to turn the belt the right way out again.

Turn the belt the right way out and sew the opening closed.

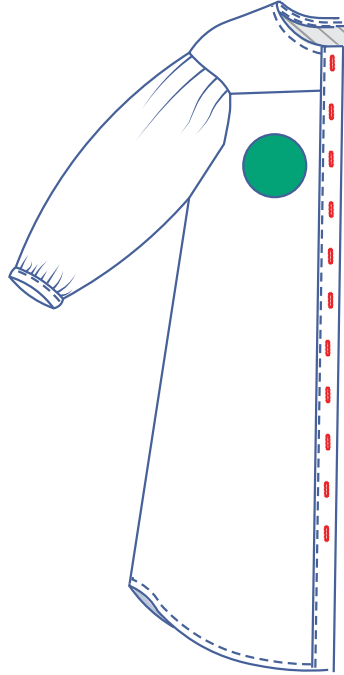
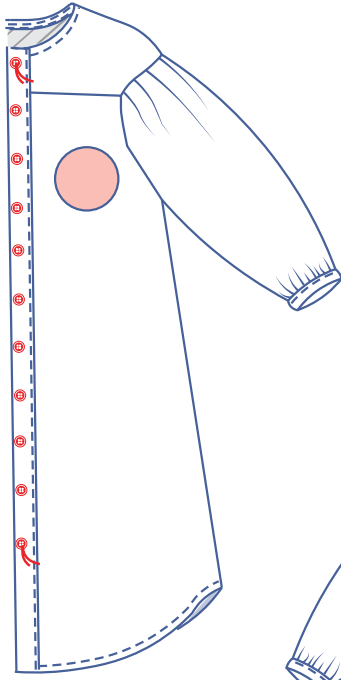

11

Sew the buttons onto the LF. The top and bottom button locations have been marked on the pattern for you. Divide the distance between them evenly to determine the location of the other buttons.

Make vertical buttonholes in the RF based on the location of the buttons.