

Giselle by Fibre ood



Giselle by Fibre ood



XS - XXXL

We love coats! Especially coats so comfy you want to nestle in them for a lifetime. Giselle is a knee-length coat with a zip, straight set-in sleeves, and a standing collar. Tighten at the waist or don't. We went for a wonderfully warm quilted fabric. The slits in the side seam give Giselle an elegant touch. Giselle is a reminder of chilly temperatures around the bend.

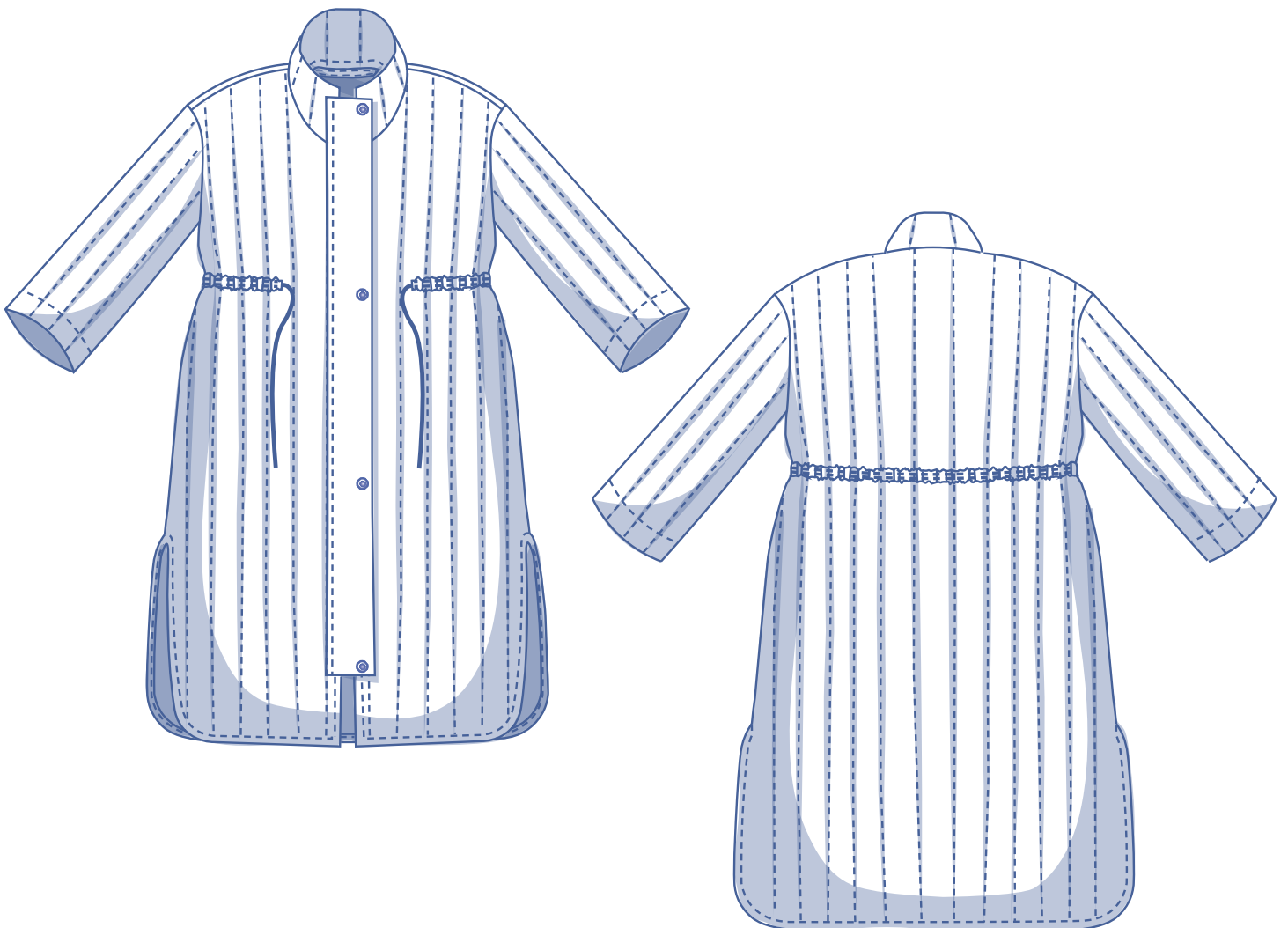

size chart (in inches)

size	XS		S		M		L		XL		XXL		XXXL		
	0	2	4	6	8	10	12	14	16	18	20	22	24	26	28
body height	5' 25"	5' 38"	5' 45"	5' 48"	5' 51"	5' 54"	5' 58"	5' 61"	5' 64"	5' 64"	5' 64"	5' 64"	5' 64"	5' 64"	5' 64"
B (bust)	29.9	31.5	33.1	34.6	36.2	37.8	39.4	40.9	43.3	45.7	48	50.4	52.8	55.1	57.5
H (hips)	33.9	35.4	37	38.2	39.4	40.6	41.7	42.9	45.3	47.2	49.2	51.2	53.1	55.1	57.1

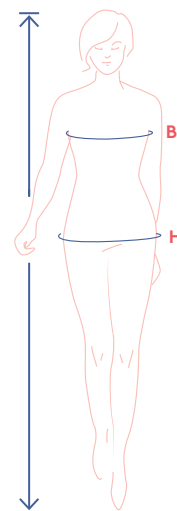

Choose your size based on your **bust measurement**. Is your hip measurement wider than what's listed in the size chart? If so, check the hip measurement in the size chart below to see if there is enough room or whether the pattern needs to be altered. It's easy to do. When tracing the pattern, simply trace from the line of one size to the line of the other size.

pattern measurements (in inches)

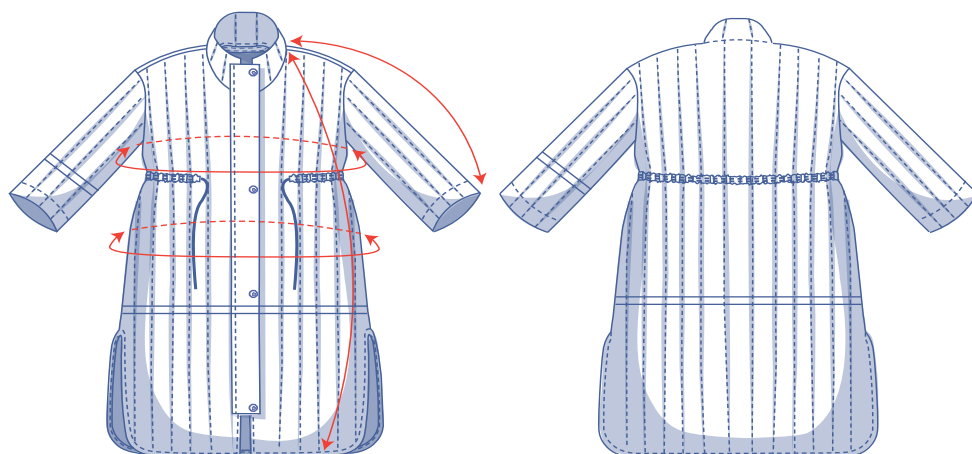

This chart's measurements are the pattern measurements based on the fabric type and serve as a reference. Ease has been added to the width measurements (in addition to the exact body measurements) for a more comfortable fit. Giselle is designed to have a **relaxed cut**.

Depending on the preferred cut, you could decide to go a size smaller or larger than the recommended size.

== shorten or lengthen the pattern here

size	XS	S	M	L	XL	XXL	XXXL
length	44.5	44.9	45.3	46.2	47.2	48.2	48.8
sleeve length*	27.1	27.8	28.4	29	29.7	30.3	31
bust	42.6	45.8	48.9	52.1	56	60.7	65.5
hips	48.2	51.3	54.5	57.6	61.6	66.3	71

* Including shoulder length.

Compare the stated lengths to the measured or desired lengths. **Lengthen** or **shorten** the coat and/or sleeves by cutting the pattern pieces at the indicated double lines. Then either increase the distance between the cut pieces by the desired amount (to lengthen) or overlap the pieces (to shorten). Make sure that the CF and CB lines and the side seams are always straight.



IMPORTANT

Adjust the amount of fabric to be used based on these alterations.

notions



- Thread
- Snaps (Ø 5/8"): 4
- Open-end zip: 31" (XS - XXL) or 36" (XXXL)
- Drawstring: see table
- Bias tape (folded width 3/4"): see table
- Fabric 1 = padded fabric: see table
- Fabric 2 = unpadded fabric: see table

drawstring		XS	S	M	L	XL	XXL	XXXL
length	yd	1.53	1.59	1.70	1.75	1.86	2.02	2.13

bias tape		XS	S	M	L	XL	XXL	XXXL
collar bottom	yd	0.59	0.6	0.61	0.61	0.62	0.62	0.63
hem	yd	2.85	2.938	3.03	3.16	3.27	3.44	3.57
CF	yd	2x1.11	2x1.119	2x1.13	2x1.15	2x1.19	2x1.22	2x1.23
total	yd	5.66	5.774	5.89	6.07	6.27	6.50	6.68

fabric 1		XS	S	M	L	XL	XXL	XXXL
fabric width 43"	yd	3 1/2	3 1/2	3 3/4	3 3/4	3 3/4	4 1/2	4 1/2
fabric width 55"	yd	2 1/4	2 3/4	3	3	3 1/4	3 1/4	3 1/4

The corresponding fabric layout can be found on page 6 of these sewing instructions.

fabric 2		XS	S	M	L	XL	XXL	XXXL
fabric width 43"	yd	1 1/4	1 1/4	1	1 1/2	1 1/2	1 3/4	1 3/4
fabric width 55"	yd	1	1	1	1	1	1 1/2	1 3/4

The corresponding fabric layout can be found on page 6 of these sewing instructions.

fabric advice Giselle is a perfect match for padded, quilted, or matelassé fabrics. But...you're perfectly free to ditch the padding for something simpler.



pattern pieces & seam allowances (in inches)

To sew the garment as described in the instructions, draw the illustrated seam allowances around the paper pattern pieces before cutting them out. If you are using a PDF pattern, the pattern can be printed with or without seam allowance.

To find out more, watch the [video](#).

1. front: 2x
2. back: 1x on fabric fold
3. sleeve: 2x
4. collar: 2x on fabric fold
5. zip placket: 1x
6. zip lining: 1x
7. tunnel: 1x on fabric fold
8. pocket: 4x

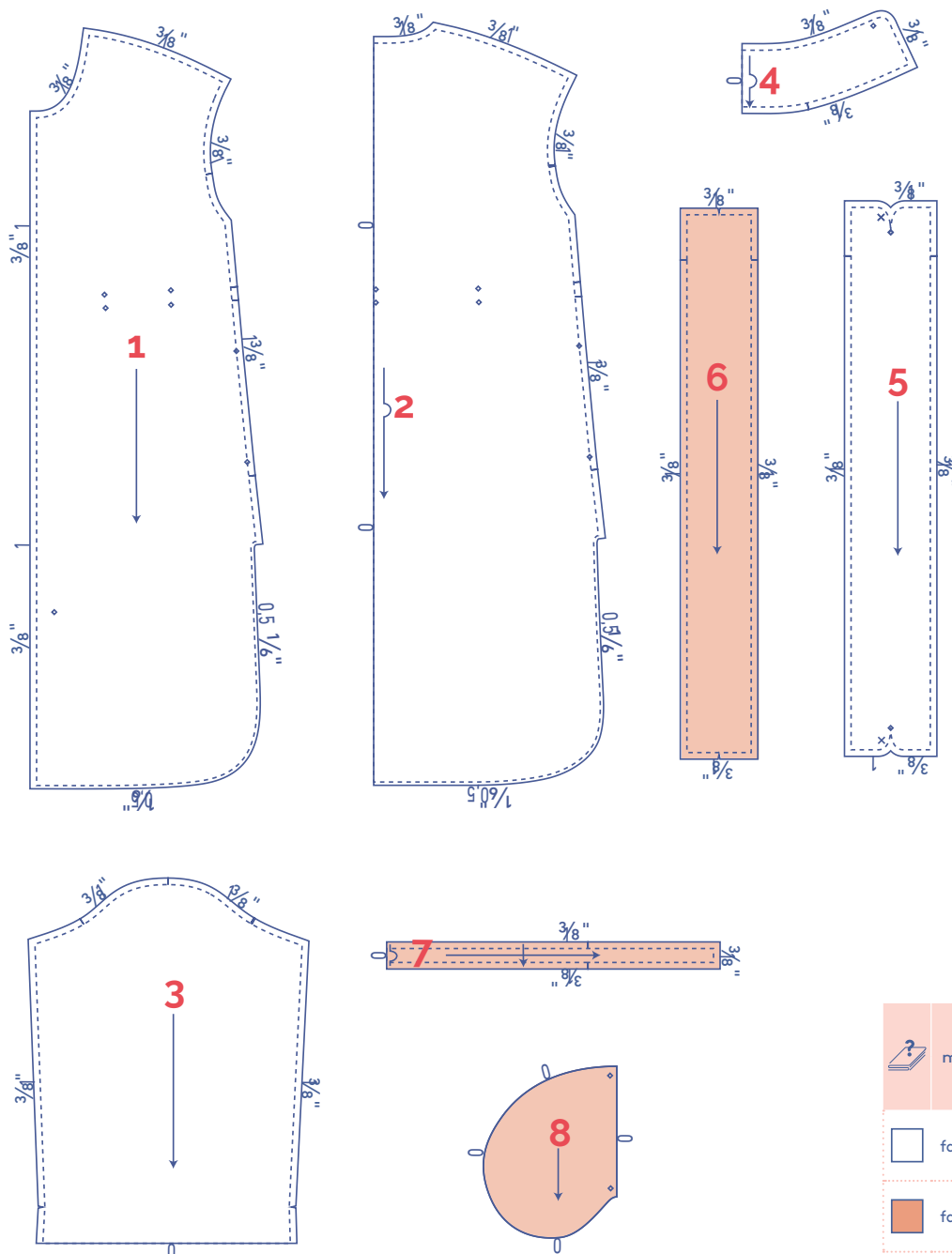

	material type
	fabric1 = padded fabric
	fabric2 = unpadded fabric

fabric layout – solid fabrics
fabric width 43"

fabric 1

XS - XL

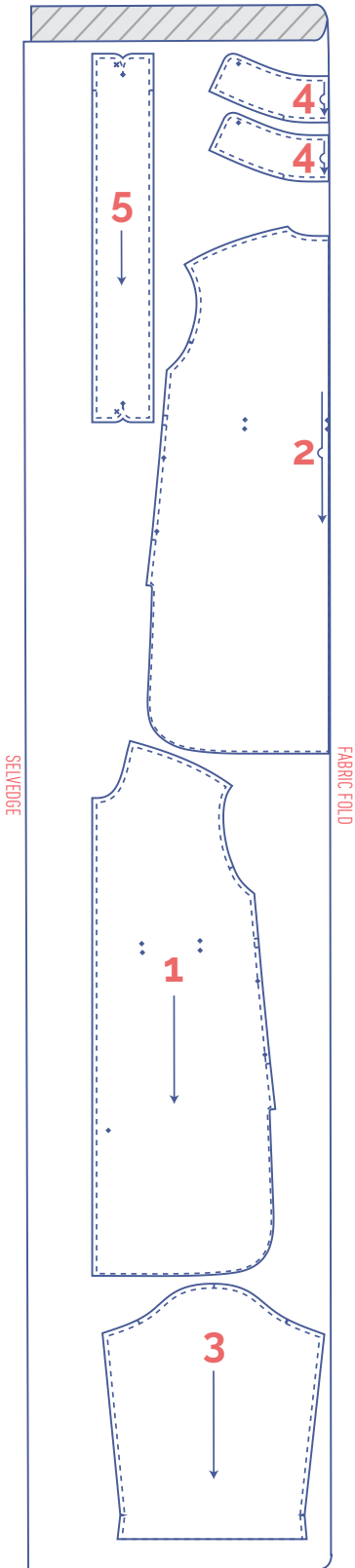

XXL - XXXL

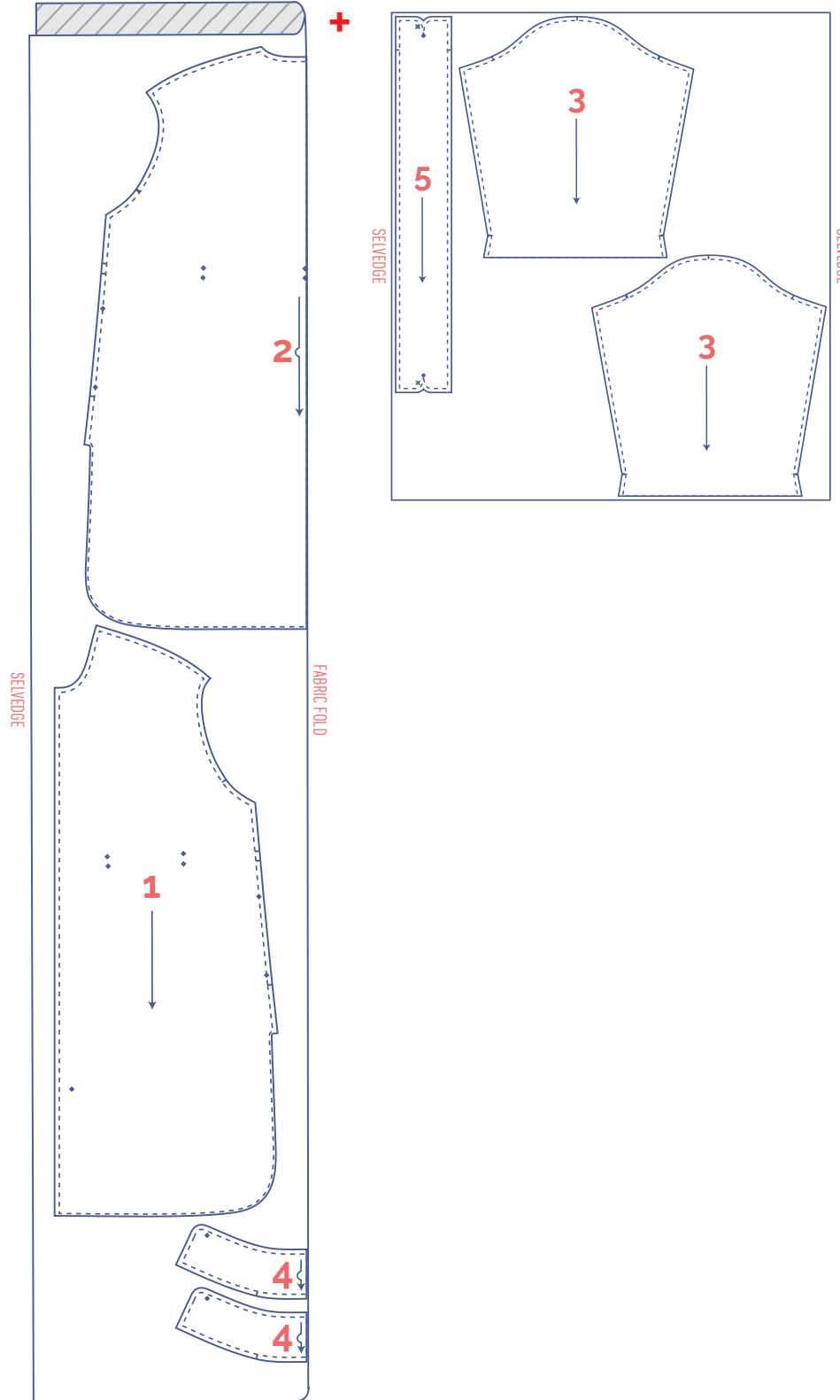

IMPORTANT

You only need pattern piece 5 once.

fabric 2

XS - M

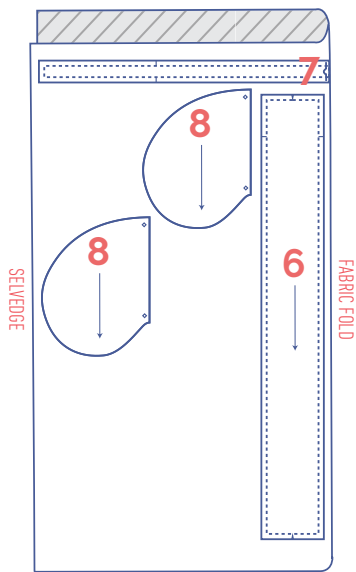

IMPORTANT

You only need pattern piece 6 once.

L - XXXL

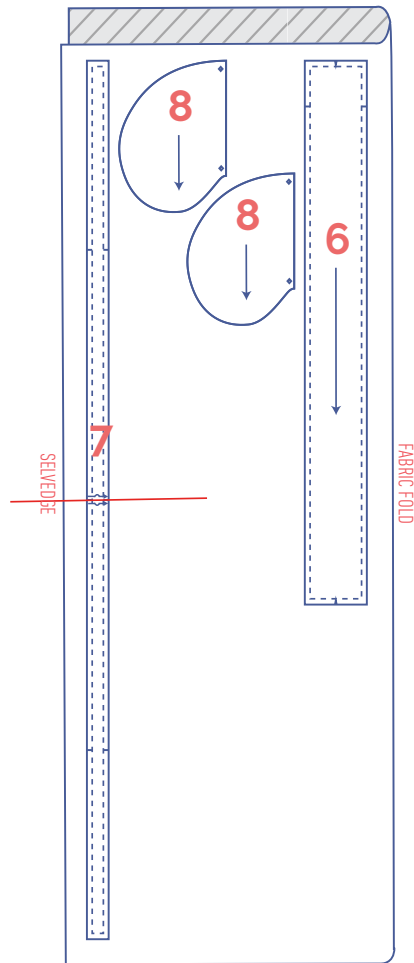

IMPORTANT

You only need pattern pieces 6 and 7 once.

fabric layout – solid fabrics
fabric width 55"

fabric 1

XS

S - XXXL

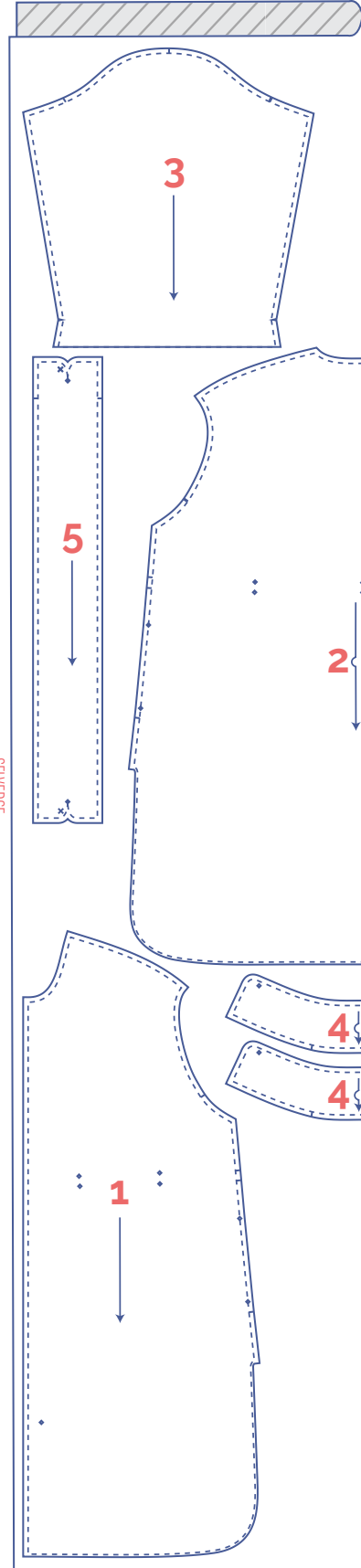
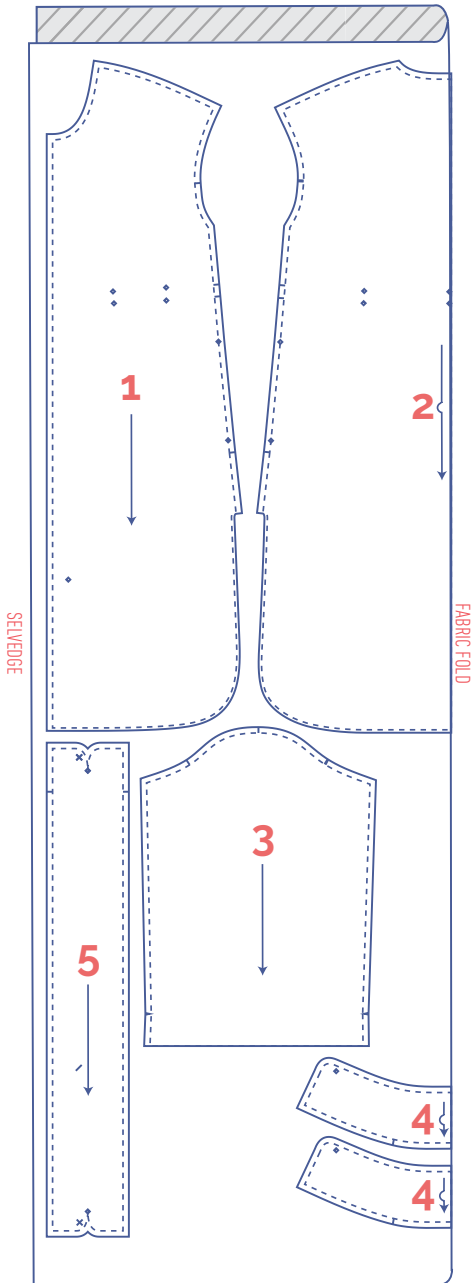

IMPORTANT

You only need pattern piece 5 once.

IMPORTANT

You only need pattern piece 5 once.

fabric 2

XS - XL

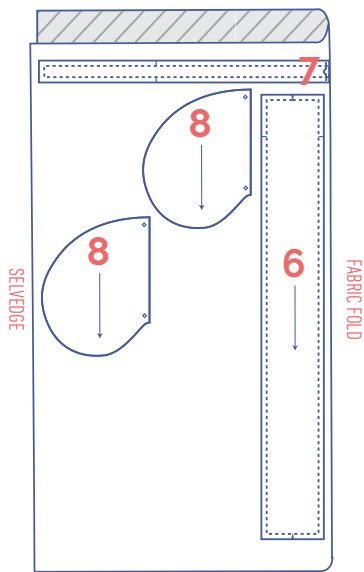

IMPORTANT

You only need pattern piece 6 once.

XXL - XXXL

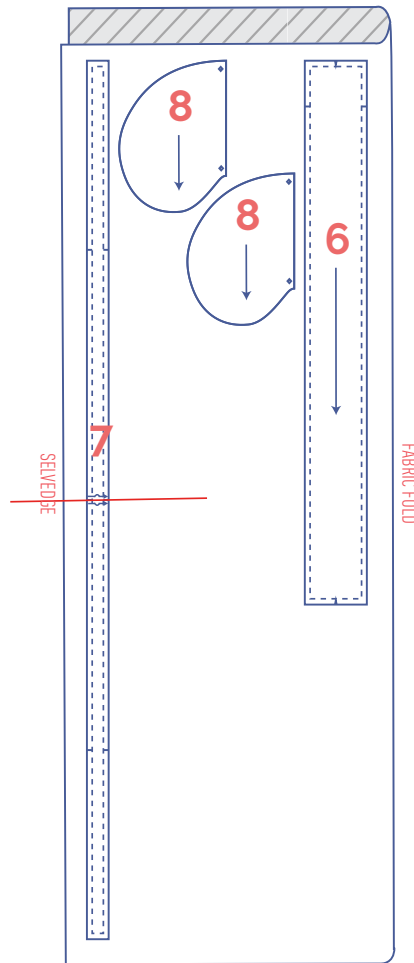

IMPORTANT

You only need pattern pieces 6 and 7 once.

marking pattern pieces

	Notch the pattern paper and fabric at the following points
	single notch
	double notch
V	V notch

	Mark the following points using marking thread
	centre point
	buttons

sewing instructions



The method used to finish the seams depends on the fabric used. The pieces are always sewn together with the right sides of the fabric facing, unless stated otherwise.



F front

B back

CF centre front

CB centre back

RF right front

LF left front

right side

wrong side

fabric 2

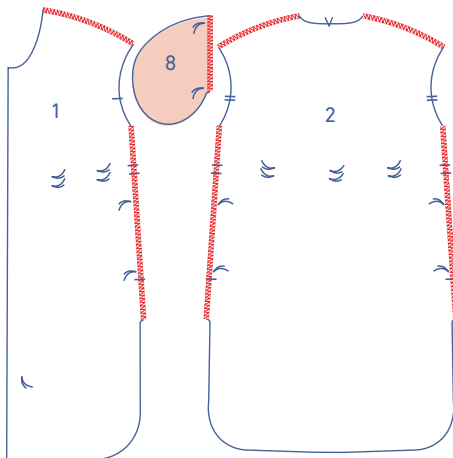
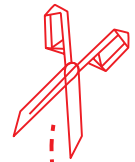

1

Finish the side seams of the front (1) and back (2) and the straight end of the pocket (8) with overlock stitching.

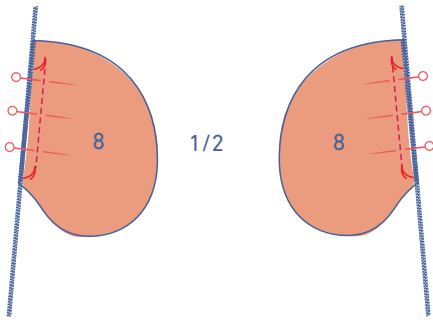

Pin the straight ends of each pocket piece to the side seams of the front and back, matching the marking threads. Sew into place between the marking threads.

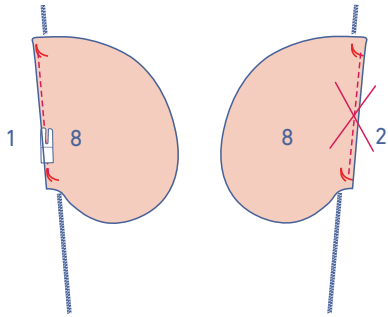

Fold the pocket attached to the front and the seam allowance over and sew the pocket to the seam allowance underneath (omit this step for the back).

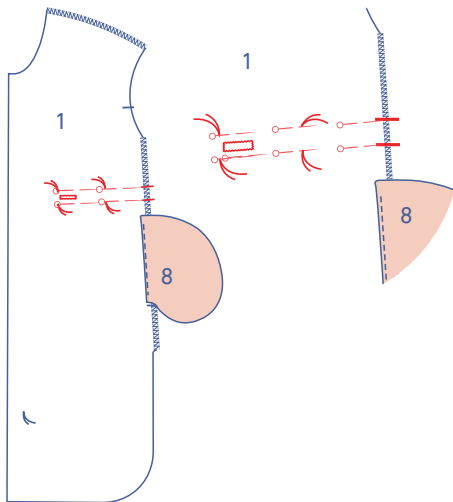

Pin between the marking threads as shown to outline where the tunnel will go.

Make a buttonhole in each front piece to thread the drawstring through later. The buttonholes should be centred and made right before the start and end of the casing.

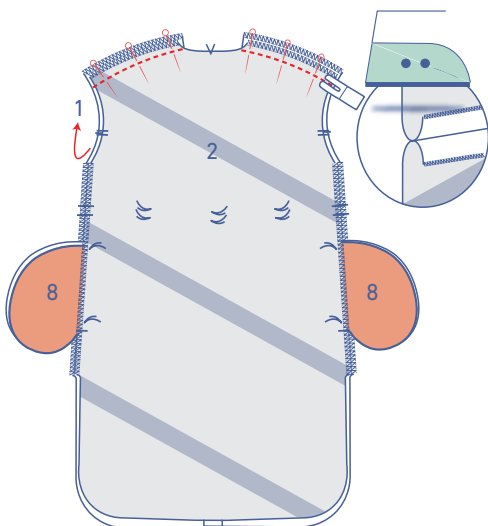

2

Pin and stitch the shoulder seams. Press the seam allowance open.

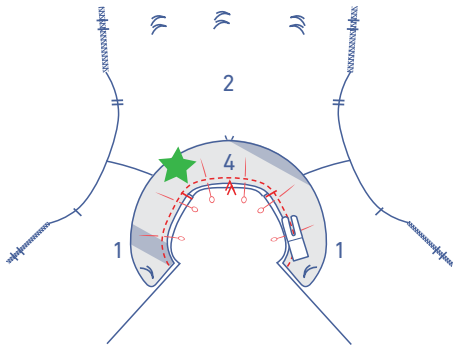

Pin and sew one of the collars to the neckline. We marked this collar with a green star.



Press the seam allowance towards the collar.

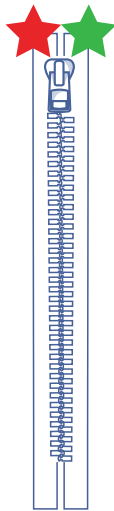

3

Place the open-end zip in front of you with the right side facing up.

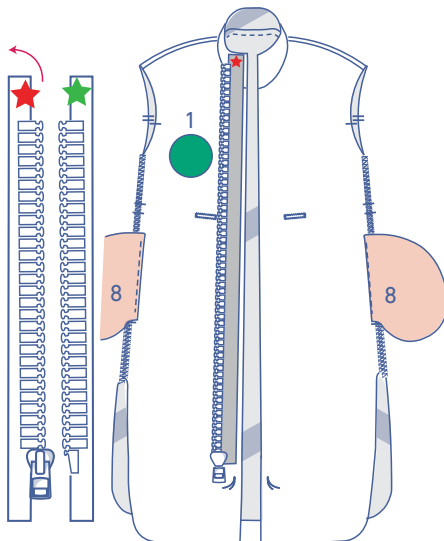

Fold the red star zip tape over to the left and place this onto the RF.

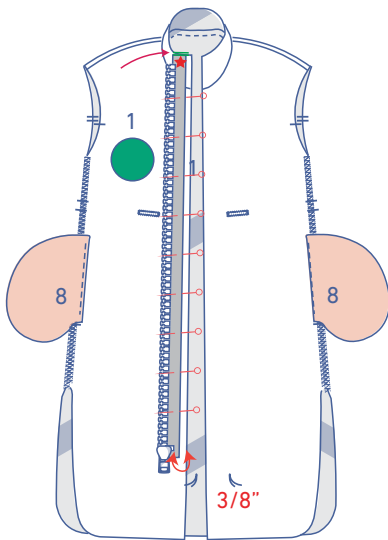

Pin the zip tape so that the middle of the zip tape is $\frac{3}{8}$ " away from the raw edge. The top of the zip should be level with the top of the collar.

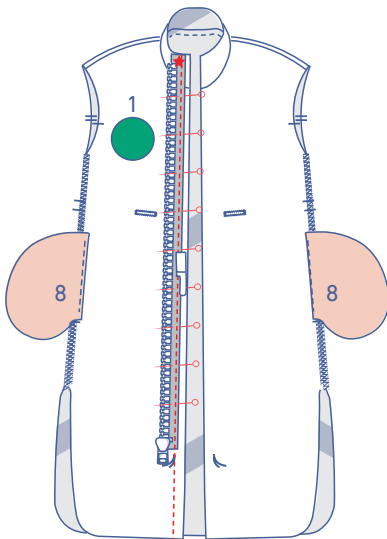

Sew into place with the zipper or narrow zipper foot. Continue stitching all the way to the hem.

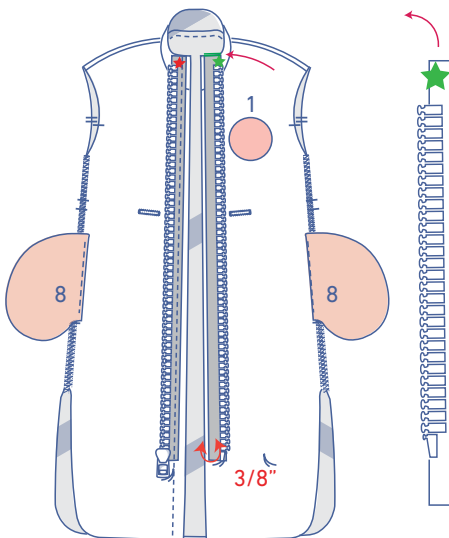

Turn the green star zip tape over to the right and place it onto the LF. The middle of the zip tape should be $\frac{3}{8}$ " away from the raw edge. The top of the zip should be even with the top of the collar.

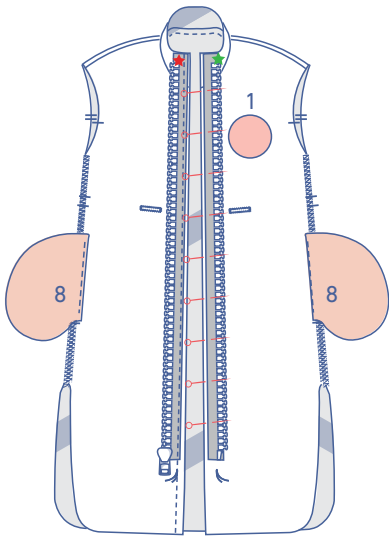

Pin the zip temporarily into place.

4

Fold the zip lining (6) in half with the long ends together and the right sides of the fabric facing.

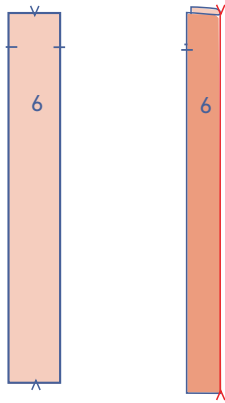

Pin and sew the short ends.

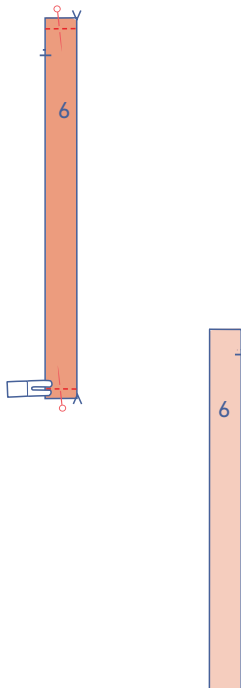

Turn the zip lining the right way out.

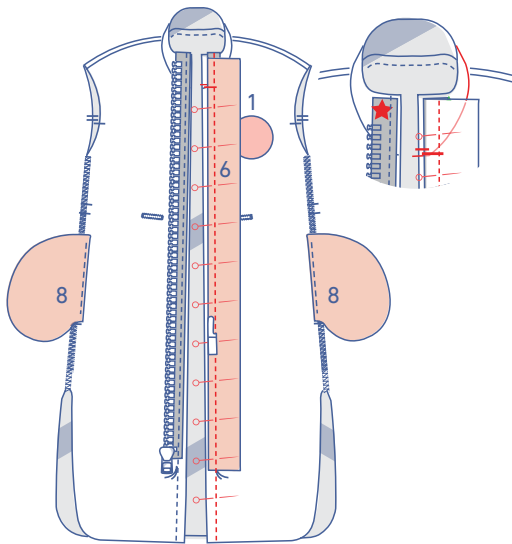

Pin the zip lining over the zip on the LF. The single notch at the top should be level with the neck seam. Sew into place with the zipper or narrow zipper foot. Continue stitching all the way to the hem.

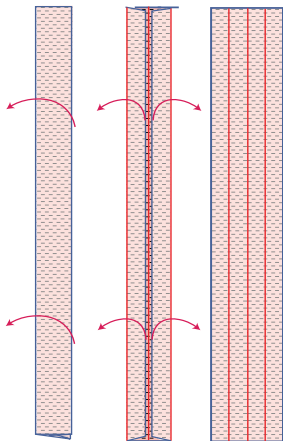

5

Open out the 2 pieces of bias tape for the CF.

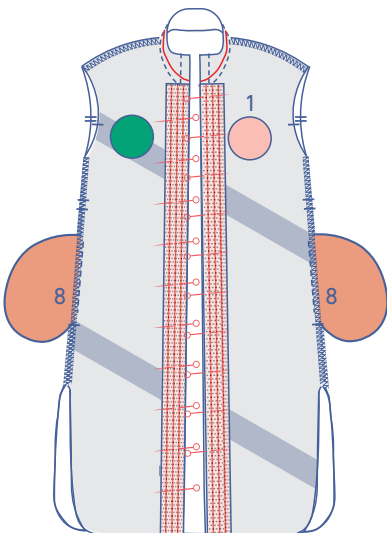

Pin the raw edge of the bias binding to the raw edge of the RF + zip tape and the LF + zip tape + zip lining along the wrong side of the front. The ends of the bias tape should be level with the lapped seam of the collar + front at the top.

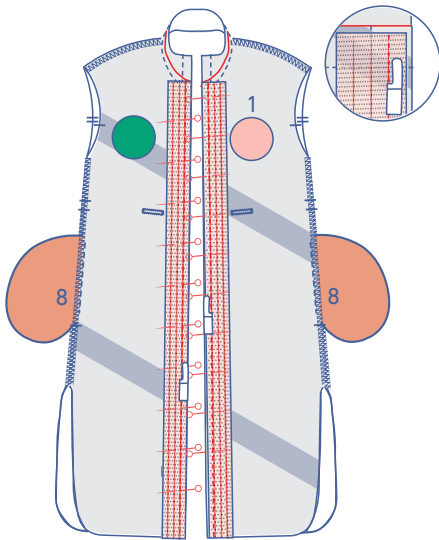

Sew into place along the first fold line with the zipper or narrow zipper foot.

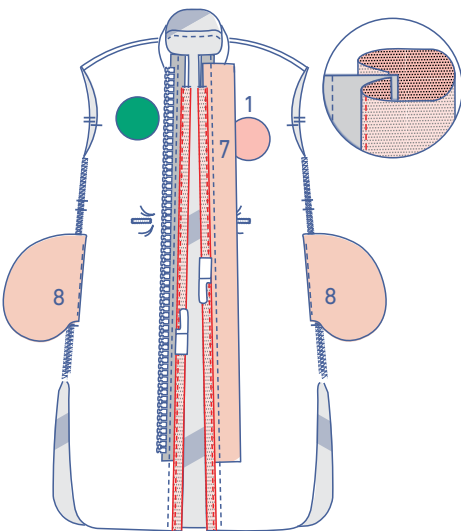

Fold the bias tape over to the right side along the centre line. Tuck under the raw edge at the fold line and sew into place right next to the edge with the zipper or narrow zipper foot.

6

Open out the bias tape for the bottom of the collar.

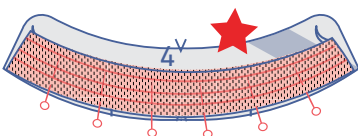
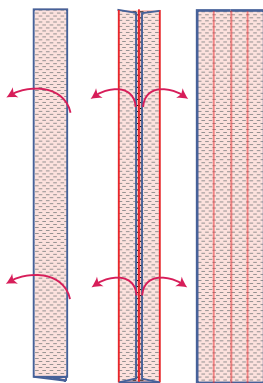

Pin the raw edge to the bottom of the undercollar along the wrong side. We marked this collar with a red star.

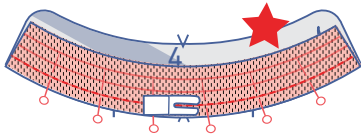

Stitch the bias tape into place along the first fold line.

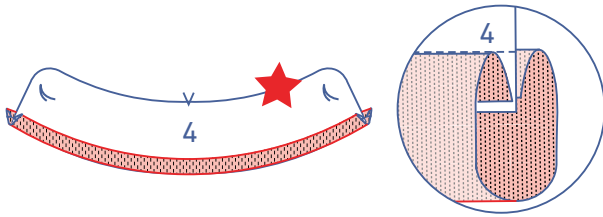

Fold the bias tape towards the right side of the collar along the centre line.

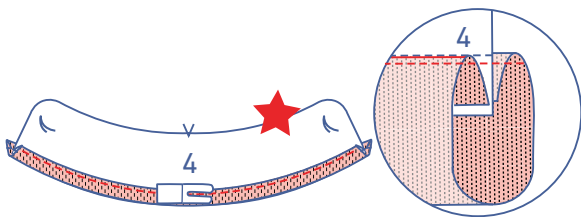

Tuck under the raw edge and edgestitch the bias tape into place.

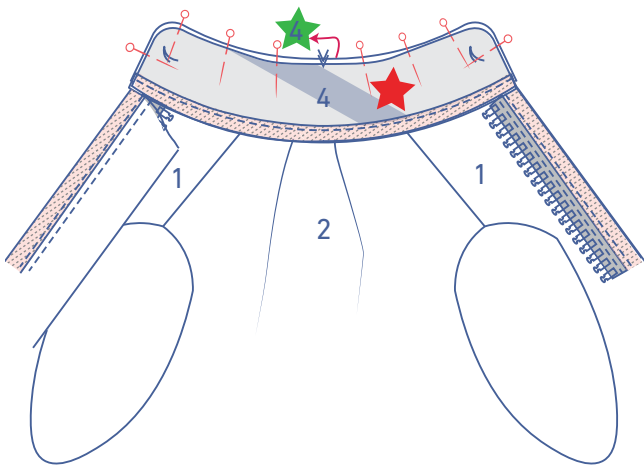

Pin the undercollar (collar with the red star) to the upper collar (collar with the green star). The zip tape should be sandwiched between 2 layers of fabric, with the zip teeth pointing towards the side seam.

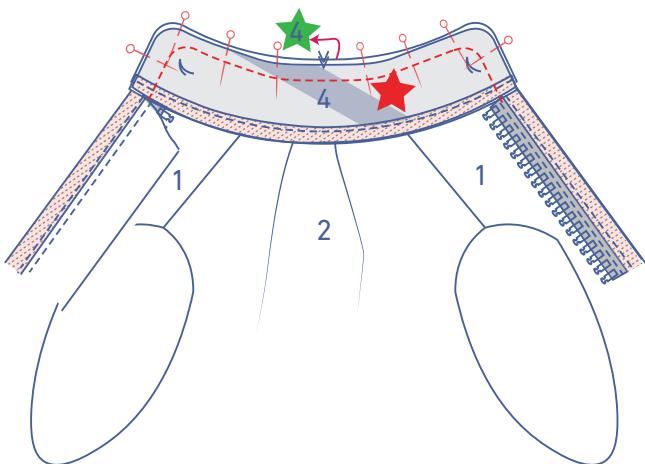

Sew the contours of the collars.

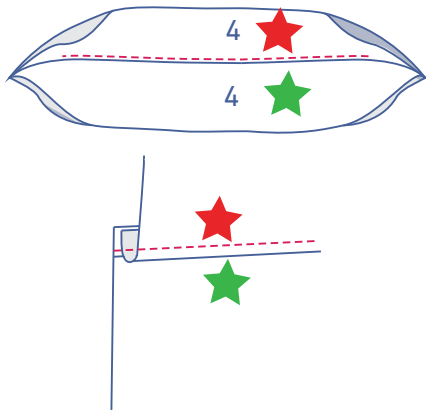

Now flip up the red star collar, move the seam allowance underneath over to the red star collar side. Stitch the seam allowance to the red star collar next to the seam. Sew as far as you can.

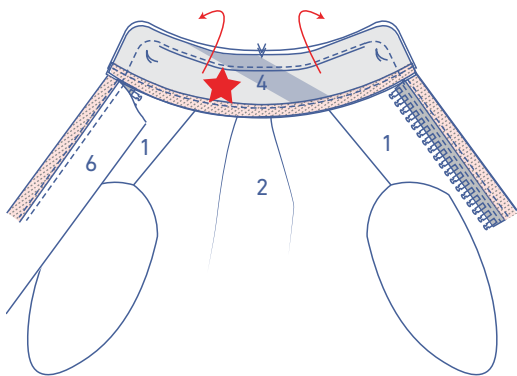

Turn the collar the right way out

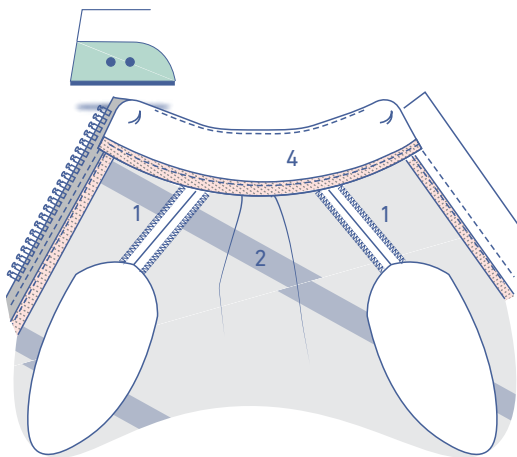

and neatly press flat.

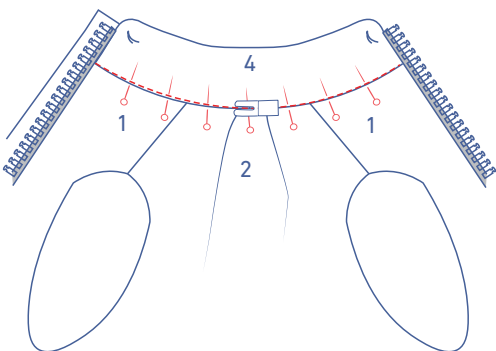

Pin the collars together along the right side. Stitch in the ditch.

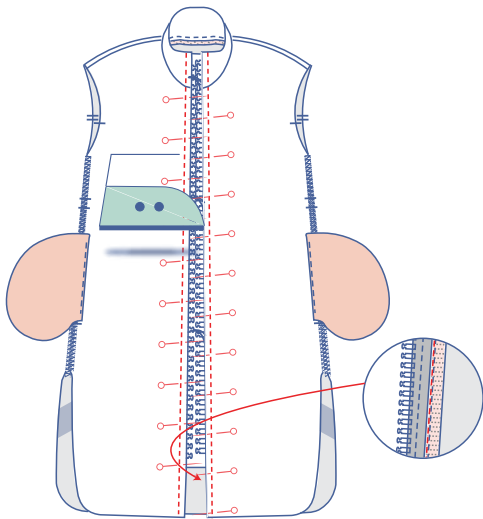

Arrange the zip tape into its final position. Pin into place along the right side of the garment. Topstitch at presser foot width from the folded edge.

7

Fold the zip placket (5) in half with the long ends together and the right sides of the fabric facing.

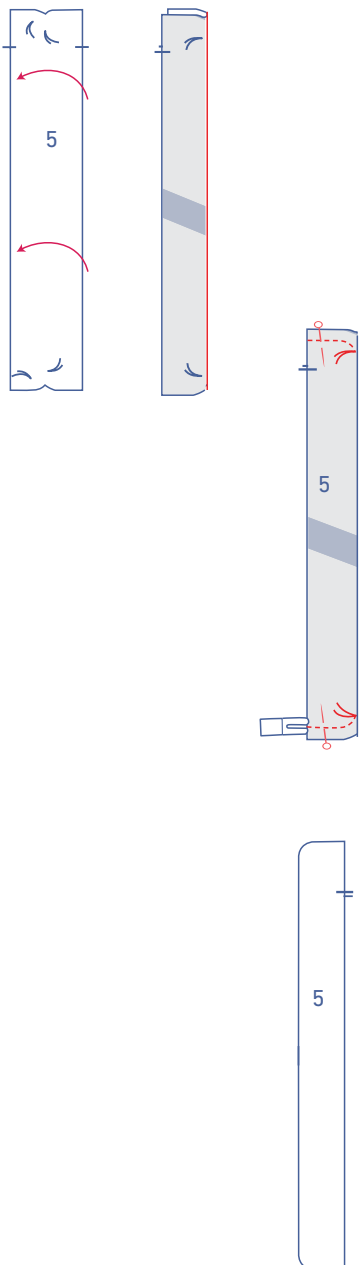

Pin and stitch the curved short ends up to the marking thread.

Turn the right way out so that the wrong sides are touching.

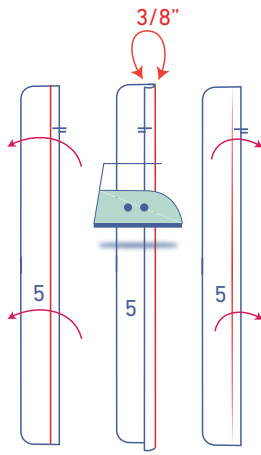

Press $\frac{3}{8}$ " of the raw edge towards the wrong side to create a fold line. Open back out again.

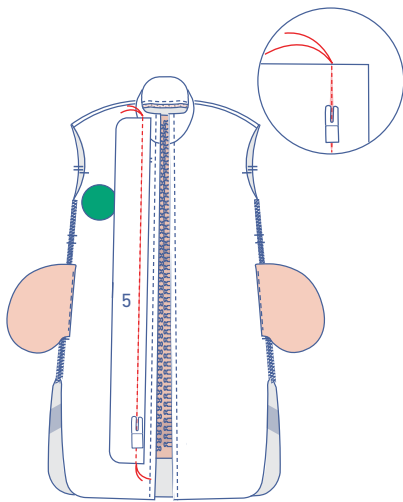

Pin the zip placket to the RF between the indicated marking threads with the right side of the zip placket facing down. Sew into place along the fold line.

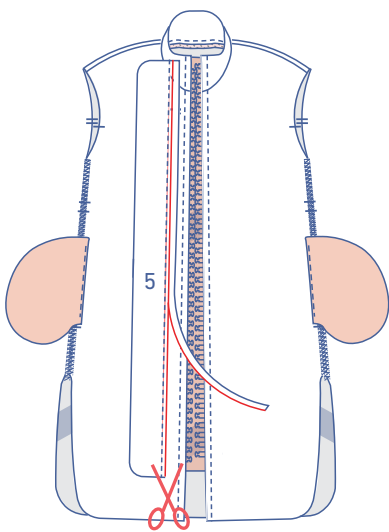

Trim the seam allowance.

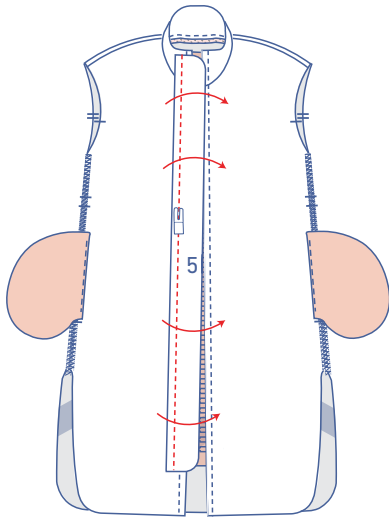

Fold the zip placket over at the seam. Sew into place at presser foot width from the seam.

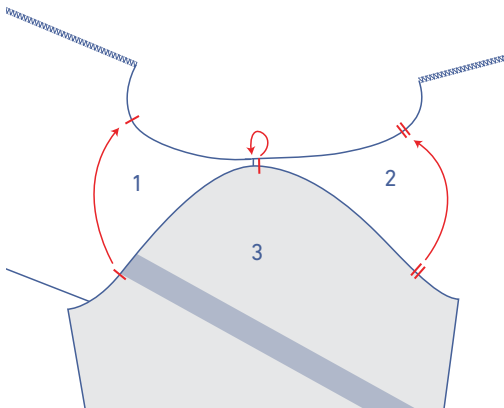

8

Pin the sleeve (3) to the armhole, matching notches. The single notch marks the front, while the double notch marks the back. The top notch should be aligned with the shoulder seam.

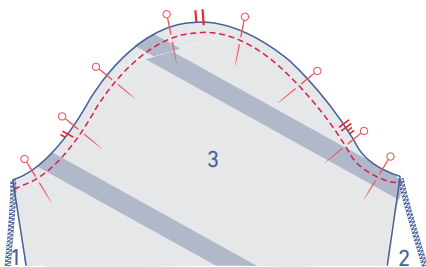

Stitch into place.

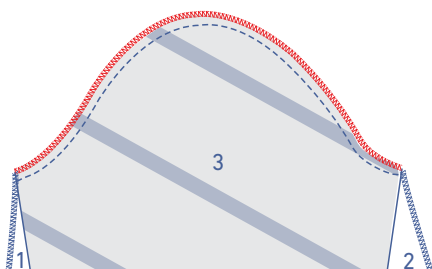

Finish the raw edges with overlock stitching.

Pin and sew the side and underarm seams up to the marking thread that marks the top of the pocket opening.

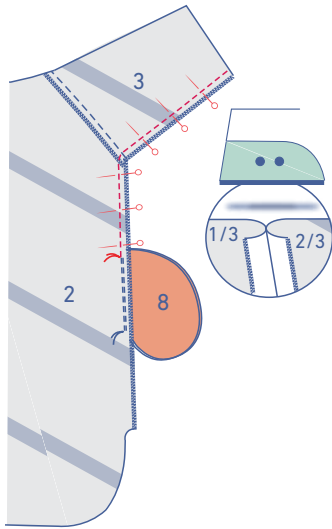

Now, stitch from the next marking thread to the slit. Press the seam allowance open.

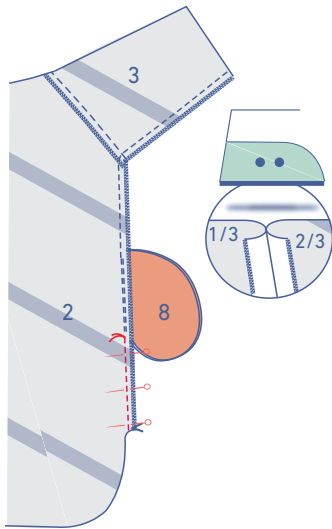

Pin and sew the contours of the pocket pieces together at $\frac{5}{8}$ ".

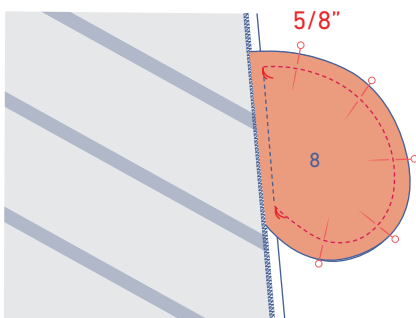

Finish the raw edges with overlock stitching.

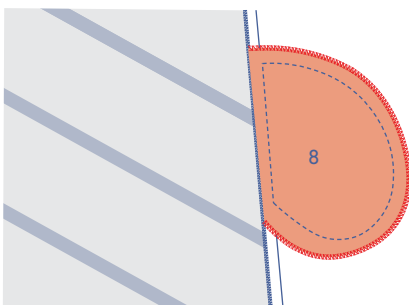

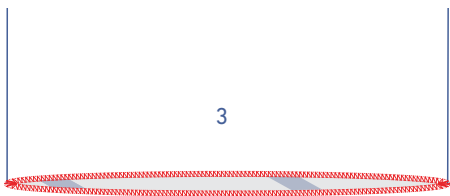

Finish the sleeve hem with overlock stitching.

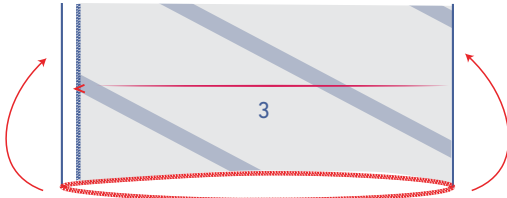

Press the hem allowance over at the V notches

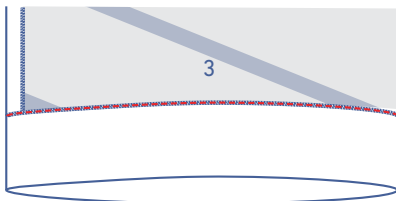

and stitch into place.

9

Open the bias tape for the hemline all the way out and press.

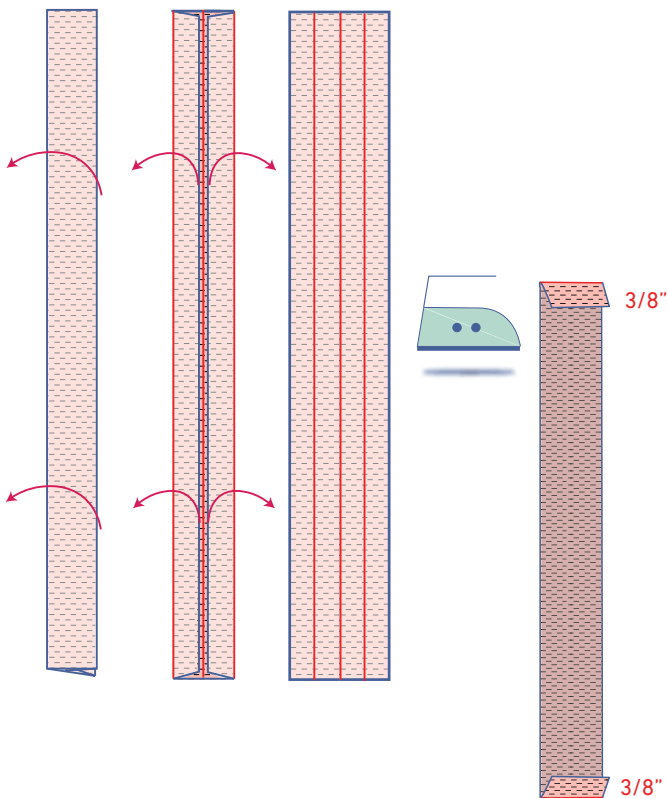

Press the short ends of the bias tape $\frac{3}{8}$ " over towards the wrong side.

Press the bias tape in half with the long ends together and the wrong sides of the fabric facing.

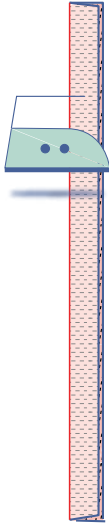

Pin raw edges to the hemline along the right side of the garment. Each of the pressed short ends should match the finished CB. Sew into place at $\frac{1}{6}$ " cm from the edge.

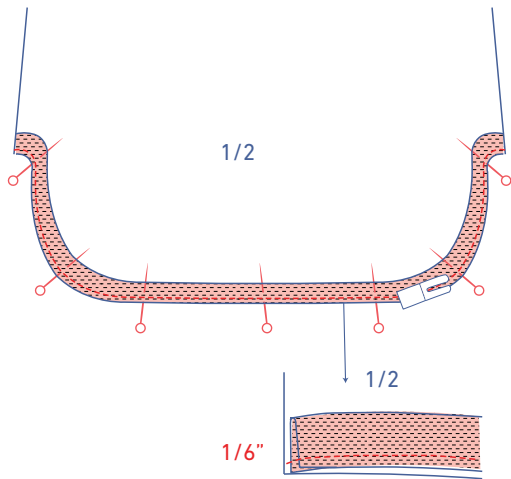

Fold the bias tape and seam allowance over and sew the bias tape to the seam allowance underneath, right next to the seam.

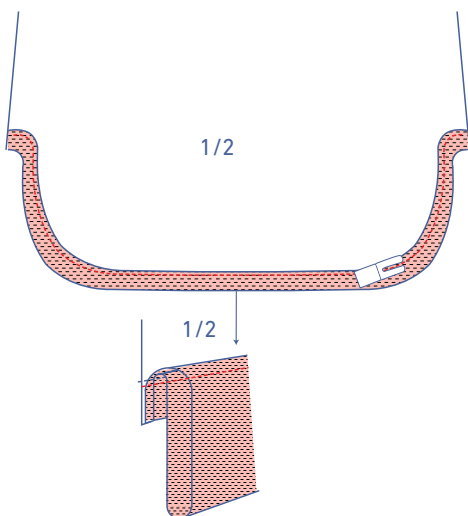

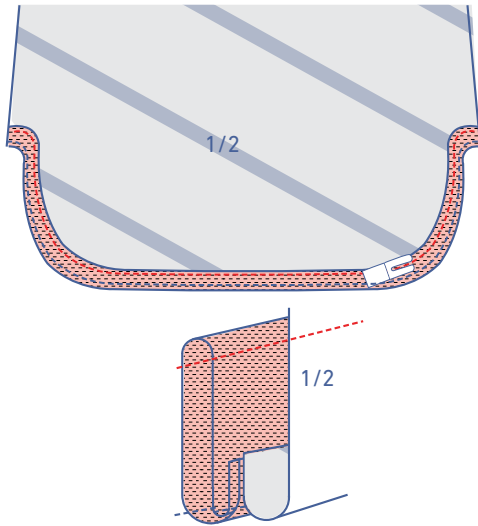

Fold the bias tape all the way over to the wrong side and edgestitch into place.

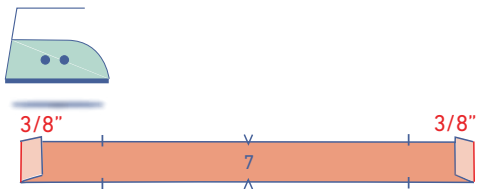

10

Press the short ends of the tunnel (7) $\frac{3}{8}$ " over towards the wrong side.

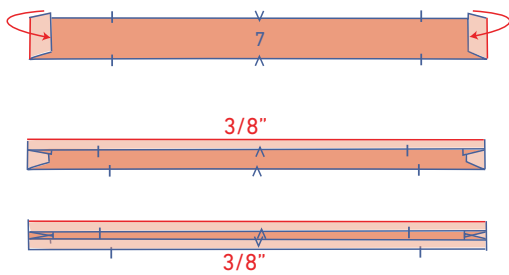

Press the long ends $\frac{3}{8}$ " over towards the wrong side.

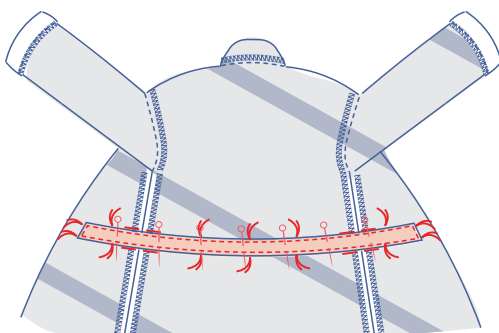

Pin the tunnel to the wrong side of the coat where indicated. Sew the casing into place right next to the edge.

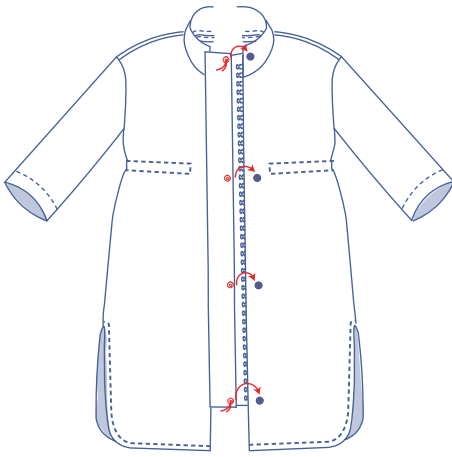

11

Attach the snaps where indicated.

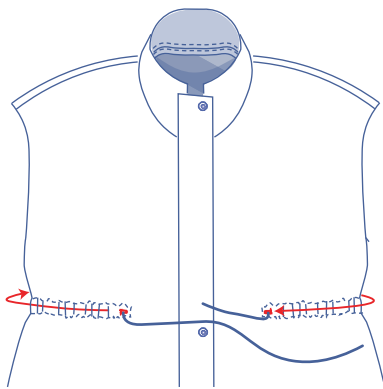

Thread the drawstring through the casing via the buttonholes in the CF.