

Gabby by Fibre ⚡ood



Gabby by Fibre ood



0 - 28

Meet Gabby, with the 'G' from 'good time' and 'graceful'. And it does it all without extravagant details, just the alluring play of lines and bust darts. This dress has a wonderful willowy drape. The triangular insert (godet) at the front is an eye-catcher although the two-in-one balloon sleeves - with a shorter inner sleeve that pulls the outer sleeve in - do give them a run for their money. Gabby's got some drama going on, but is still wonderfully simple somehow. Some people have just got *it*. No more drama? Drop the godet - simple as that.

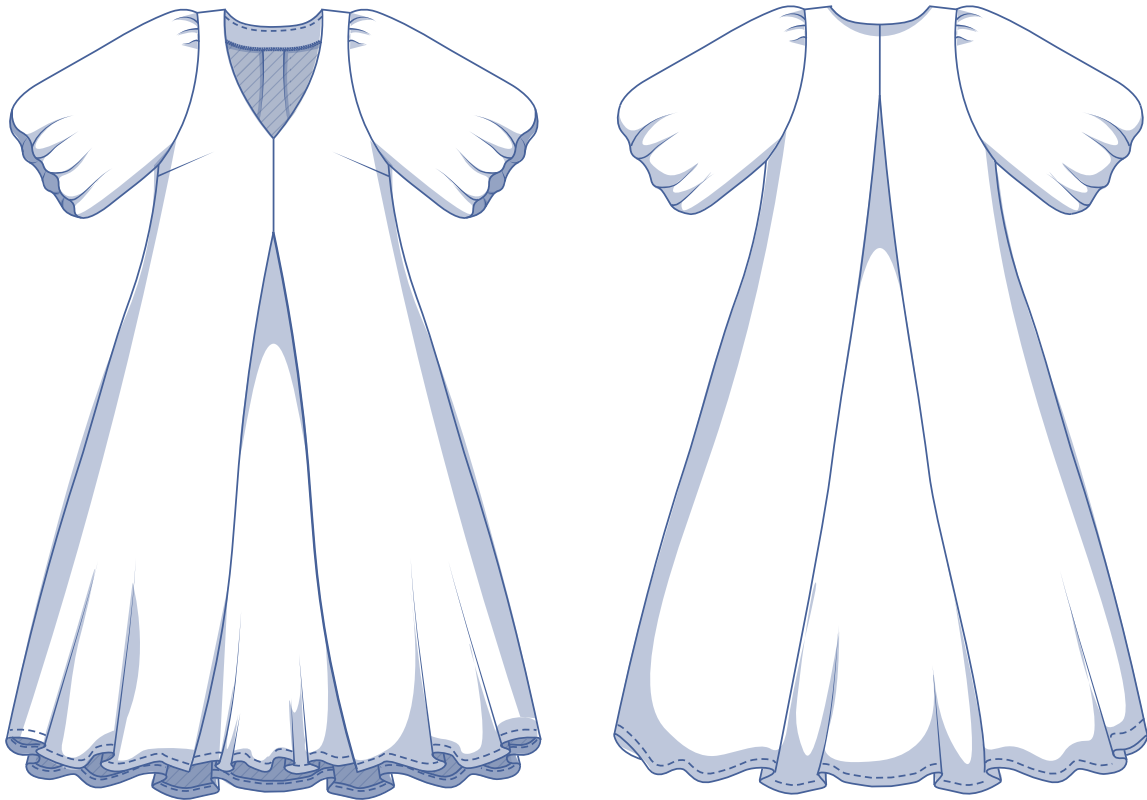

size chart (in inches)

size	0	2	4	6	8	10	12	14	16	18	20	22	24	26	28
body height	5' 25"	5' 38"	5' 45"	5' 48"	5' 51"	5' 54"	5' 58"	5' 61"	5' 64"	5' 64"	5' 64"	5' 64"	5' 64"	5' 64"	5' 64"
B (bust)	29.9	31.5	33.1	34.6	36.2	37.8	39.4	40.9	43.3	45.7	48	50.4	52.8	55.1	57.5

Choose your size based on your **bust measurement**. Pick the size that is the best match for your bust.

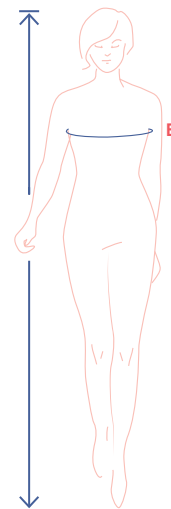

pattern measurements (in inches)

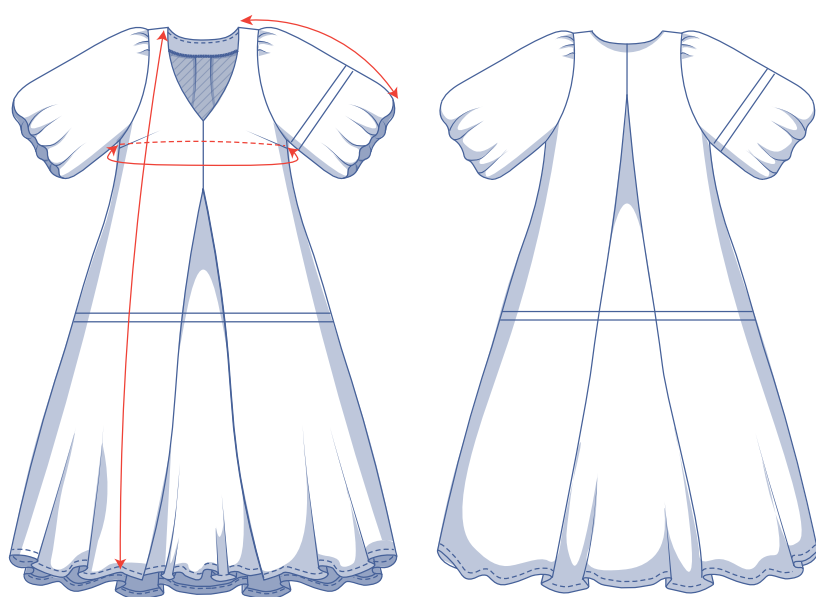

This chart's measurements are the pattern measurements based on the fabric type and serve as a reference. Ease has been added to the width measurements (in addition to the exact body measurements) for a more comfortable fit. Gabby is designed to have a **loose cut**.

size	0	2	4	6	8	10	12	14	16	18	20	22	24	26	28
length	47.8	48.1	48.3	48.5	48.7	48.9	50.0	50.2	51.7	52.0	52.3	52.7	53.0	53.2	53.5
sleeve length*	15.1	15.4	15.6	15.7	16.0	16.2	16.5	16.7	17.0	17.3	17.6	17.9	18.2	18.5	18.8
bust	34.0	35.4	37.0	38.6	40.2	41.7	43.2	44.8	47.4	49.7	52.0	54.2	56.5	58.8	61.0

* Including shoulder length.

Compare the stated lengths to the measured or desired lengths. **Lengthen** or **shorten** the dress and/or the sleeves by cutting the pattern pieces at the indicated double lines. Then either increase the distance between the cut pieces by the desired amount (to lengthen) or overlap the pieces (to shorten). Make sure that the CF and CB lines and the side seams are always straight.



IMPORTANT

Adjust the amount of fabric to be used based on these alterations.

notions



- Thread
- Iron-on interfacing: max. 2/5 yd
- Fabric: see table

fabric		0	2	4	6	8	10	12	14	16	18	20	22	24	26	28
fabric width 43"	yd	3 ¾	3 ¾	4 ½	4 ½	4 ½	*	*	*	*	*	*	*	*	*	*
fabric width 55"	yd	3 ¼	3 ¼	3 ¼	3 ½	3 ½	3 ¾	4	4	4	4 ¼	4 ½	4 ½	4 ½	4 ¾	4 ¾

The corresponding fabric layout can be found on page 6 of these sewing instructions.

* Fabric use cannot be specified because pattern piece 2 is too wide to fit on fabric that is 43" wide.

IMPORTANT

Pattern piece 3 has been positioned on the fabric bias. It looks gorgeous and creates a wonderful drape. You could also position pattern piece 3 on the straight grain to conserve fabric.

fabric advice



There are many possibilities here. Poplin, chambray, linen, lyocell, muslin, crepe (viscose, polyester...), satin, embroidery, lace... and we could go on and on. If you like statement sleeves, then definitely choose a stiff fabric. We are curious about your choice. By the way a knitted fabric is also possible....

Proud to be #Sewista

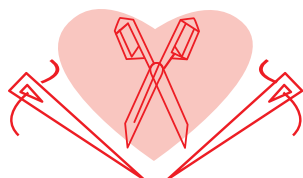

pattern pieces & seam allowances (in inches)

To sew the garment as described in the instructions, draw the illustrated seam allowances around the paper pattern pieces before cutting them out. If you are using a PDF pattern, the pattern can be printed with or without seam allowance. To find out more, watch the [video](#).

- 1. front: 2x
- 2. back: 1x on fabric fold
- 3. insert: 1x on fabric fold
- 4. sleeve: 2x
- 5. inner sleeve: 2x
- 6. pocket: 4x
- 7. facing front: 1x on fabric fold
- 8. facing back: 1x on fabric fold

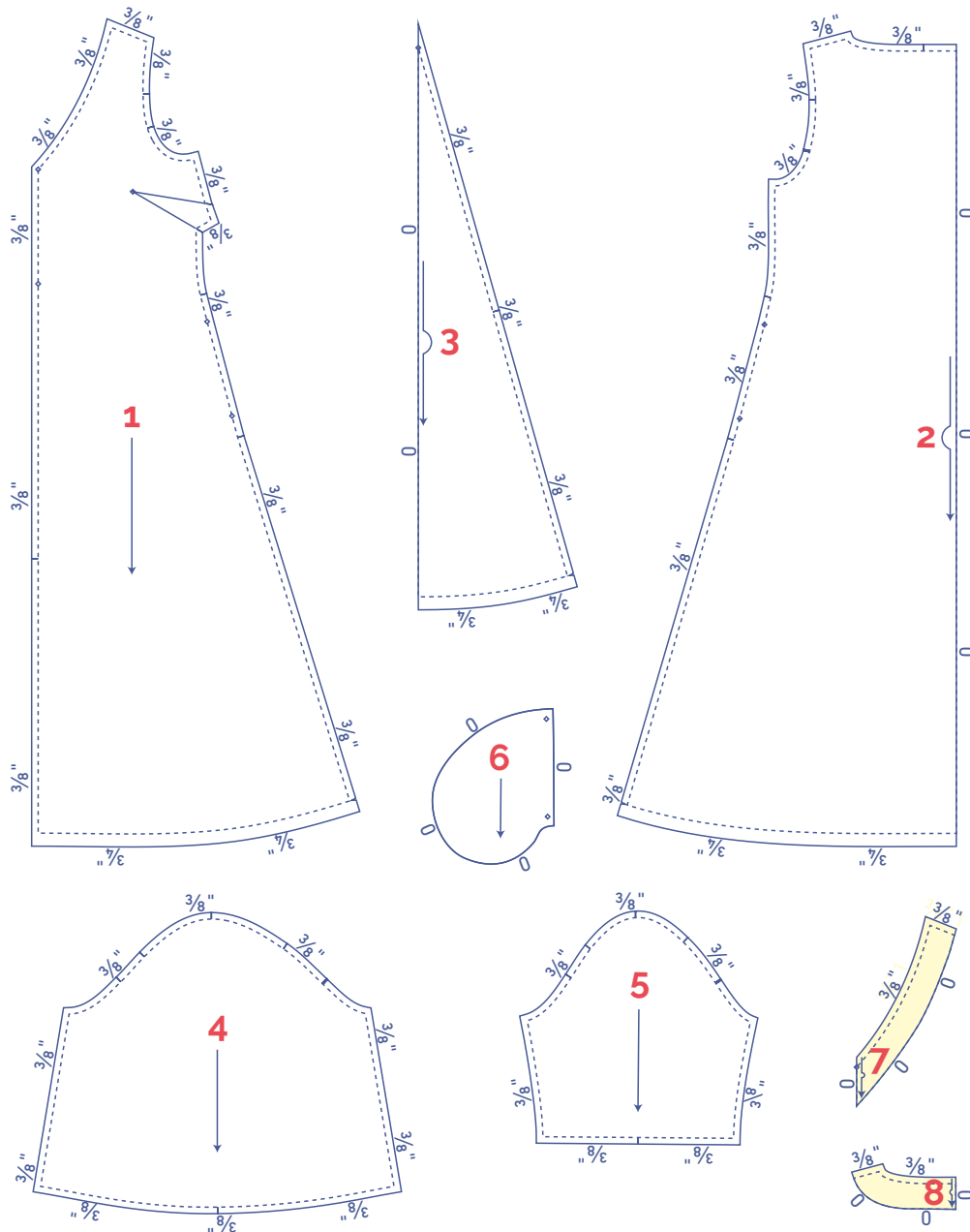

IMPORTANT

The pieces highlighted in light yellow have iron-on interfacing attached to the wrong side.

TIP

Would you prefer to make Gabby without the insert? Simply omit pattern piece 3 and cut pattern piece 1 once on the fold (remove the $\frac{3}{8}$ " of seam allowance from the centre front before you cut). Skip step 2 of the sewing instructions.



material type



fabric



iron-on interfacing

fabric layout – solid fabrics fabric width 43"

0 - 2

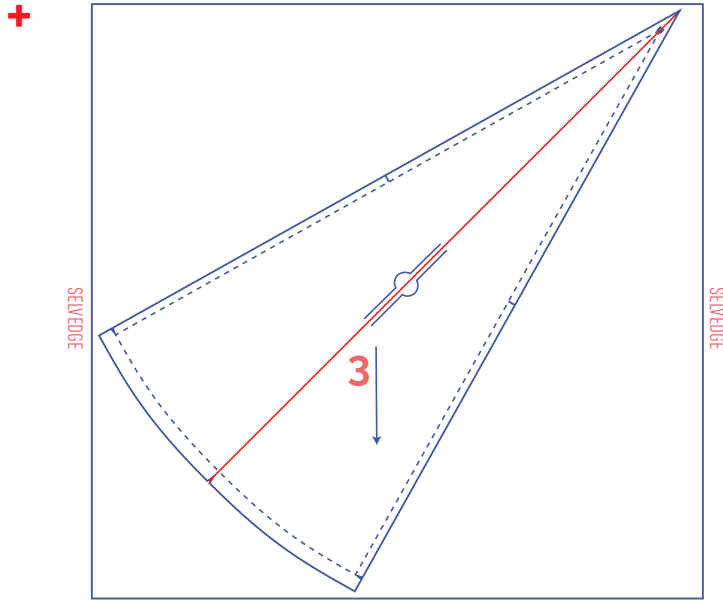
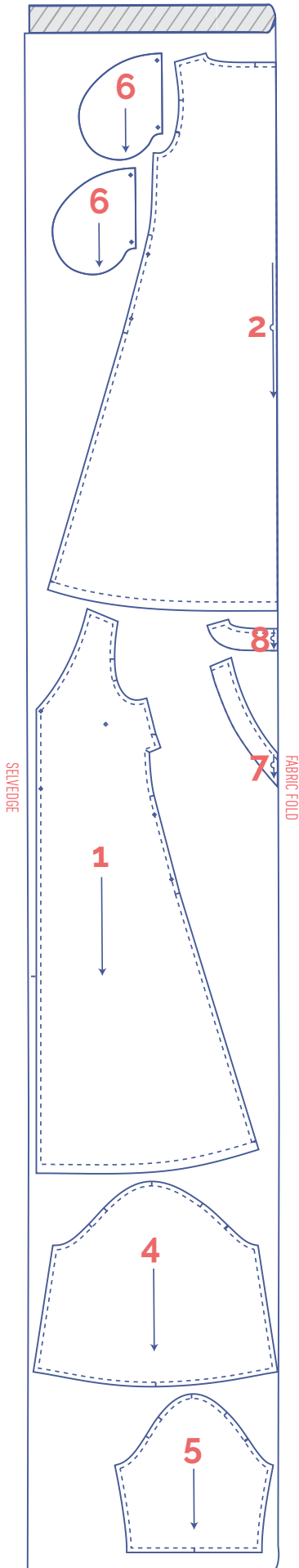

IMPORTANT

Pattern piece 3 has been positioned on the fabric bias. It looks gorgeous and creates a wonderful drape. You could also position pattern piece 3 on the straight grain to conserve fabric.

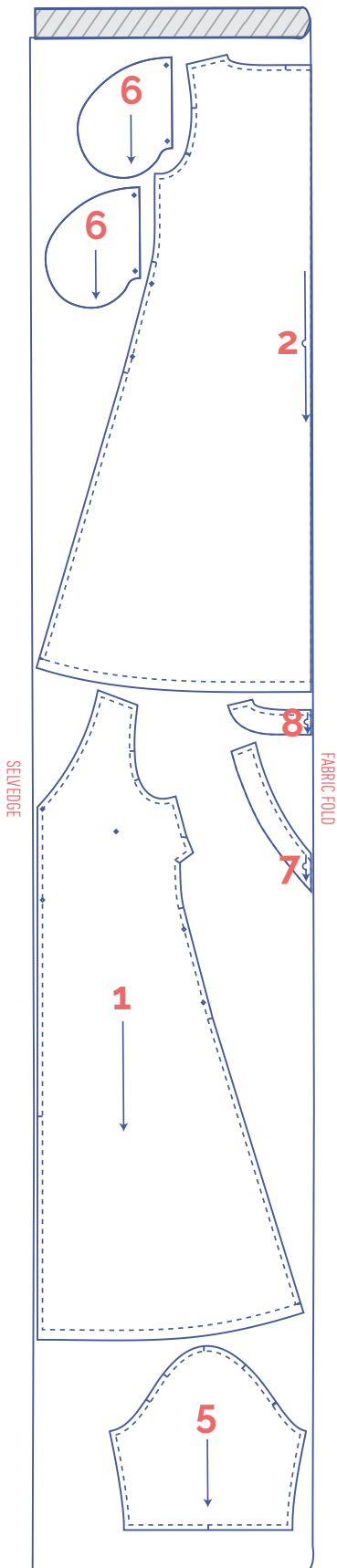

+

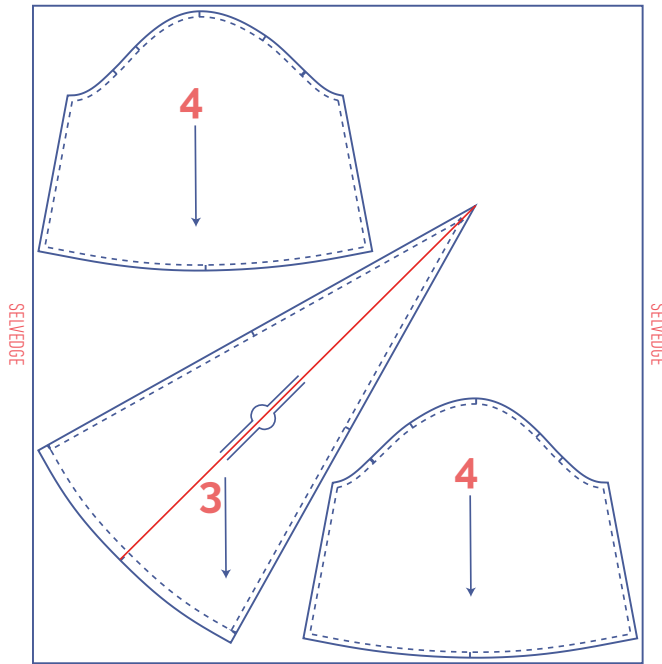

IMPORTANT

The sleeve pieces are cut on a single layer of fabric. Be sure to cut mirror images so you have a left sleeve and right sleeve.

Pattern piece 3 has been positioned on the fabric bias. It looks gorgeous and creates a wonderful drape. You could also position pattern piece 3 on the straight grain to conserve fabric.

fabric layout – solid fabrics
fabric width 55"

0 - 16

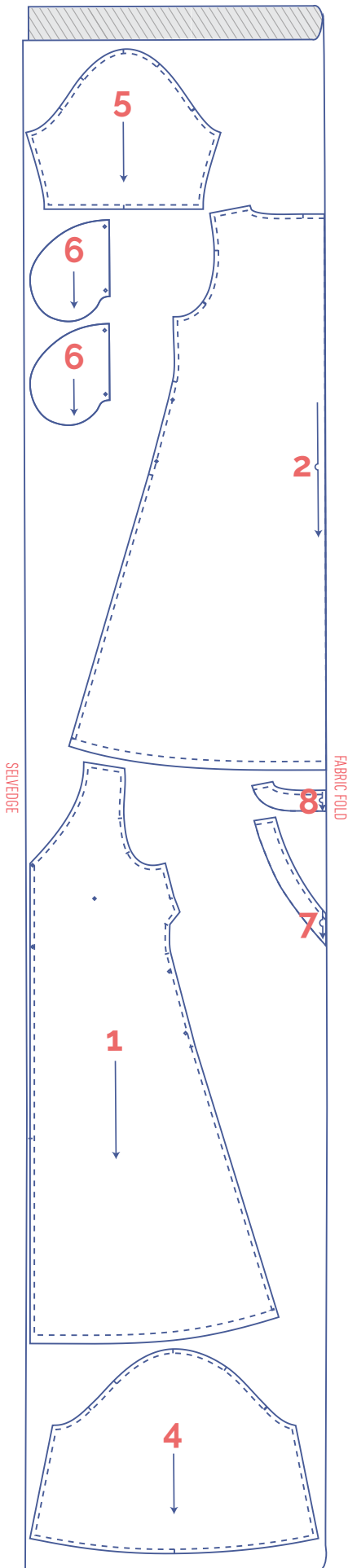

+

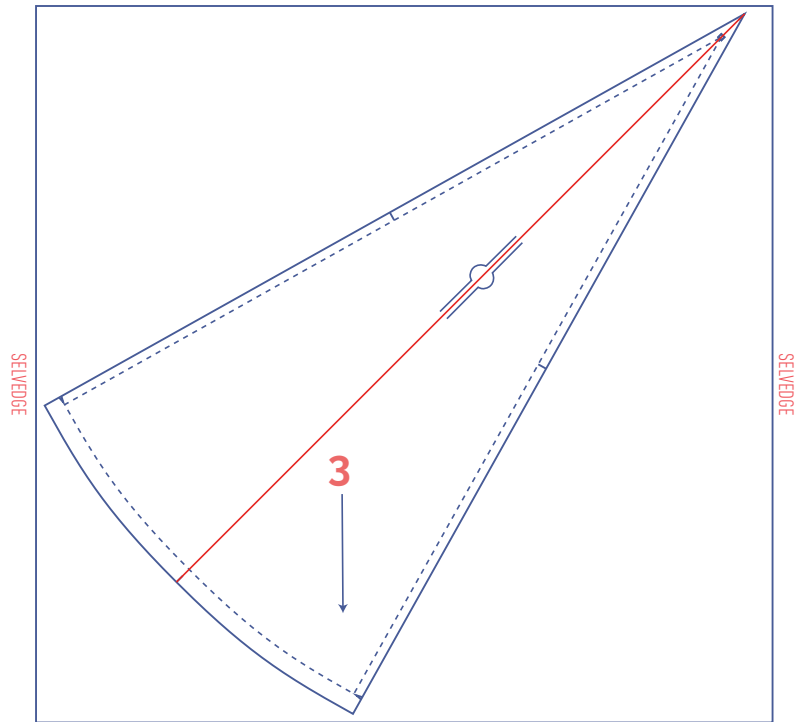

IMPORTANT

Pattern piece 3 has been positioned on the fabric bias. It looks gorgeous and creates a wonderful drape. You could also position pattern piece 3 on the straight grain to conserve fabric.

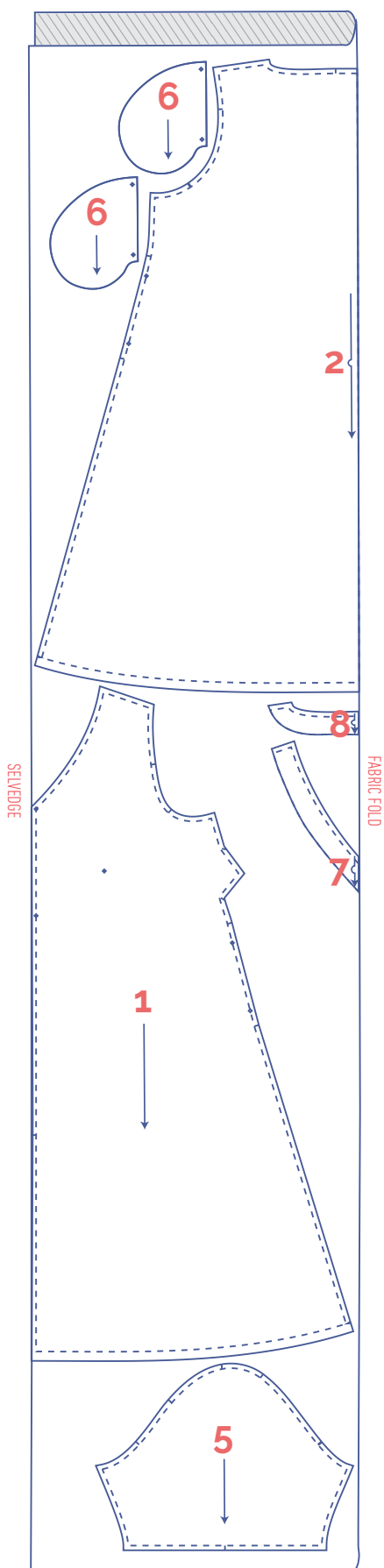

+

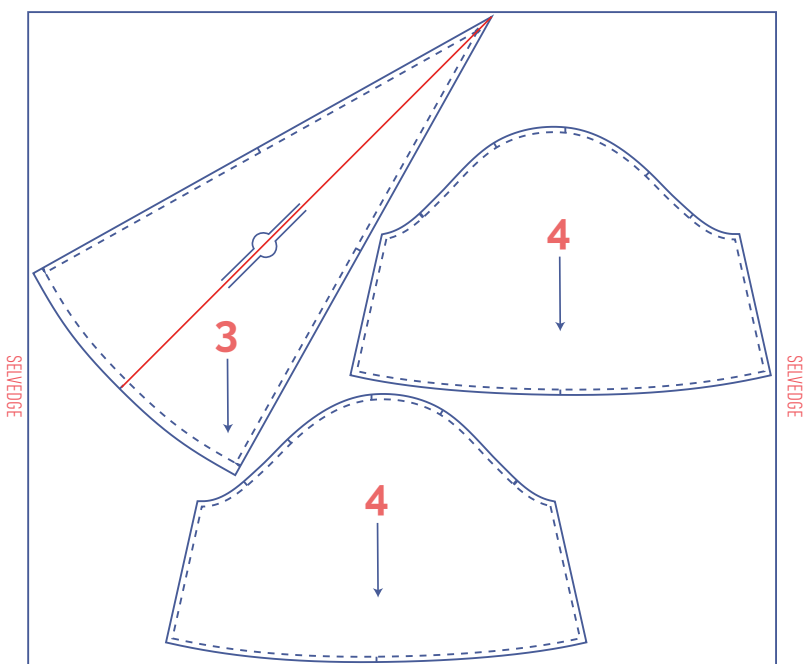

IMPORTANT

The sleeve pieces are cut on a single layer of fabric. Be sure to cut mirror images so you have a left sleeve and right sleeve.

Pattern piece 3 has been positioned on the fabric bias. It looks gorgeous and creates a wonderful drape. You could also position pattern piece 3 on the straight grain to conserve fabric.

marking pattern pieces

	Notch the pattern paper and fabric at the following points
	single notch
	double notch
V	V notch
	Mark the following points with marking thread
	centre point

sewing instructions



The method used to finish the seams depends on the fabric used. The pieces are always sewn together with the right sides of the fabric facing, unless stated otherwise.



F front piece

B back piece

CF centre front

CB centre back

 right side

 wrong side

 iron-on interfacing

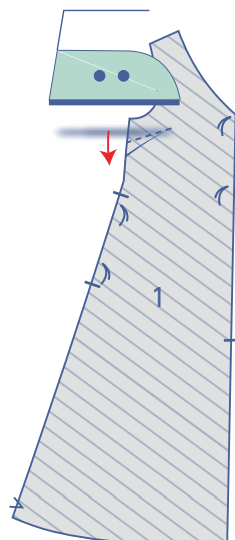
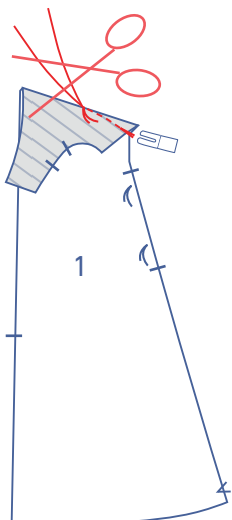
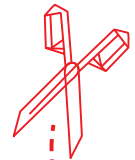

1

Fold over the top part of the front (1) right sides together and match the dart notches in the side seam. Stitch the dart in a slightly curved line towards the marking thread. Stitch up to and just past the marking thread, so that you've sewn past the fabric. Snip the threads and tie a knot.

Turn the front over so that the wrong side is facing up. Press the dart down.

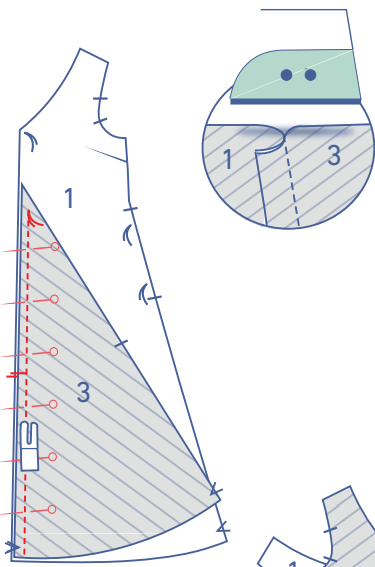

2

Pin and sew the insert (3) to one of the front pieces, stitching from the marking thread to the hem. Press the seam allowance towards the front.

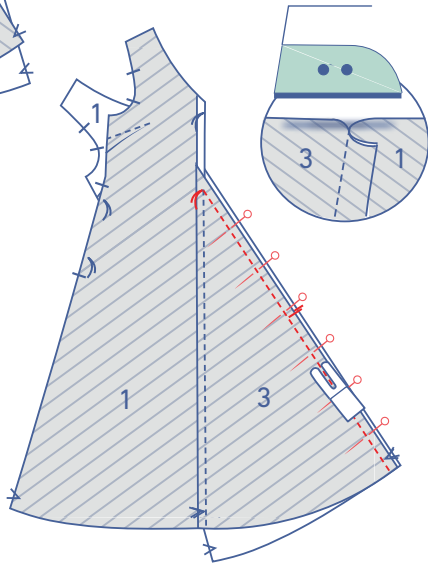

Pin and sew the other side of the insert to the other front piece, keeping the seam allowance of the previous stitching out of the way. Once again, sew from the marking thread to the hem. Press the seam allowance towards the front.

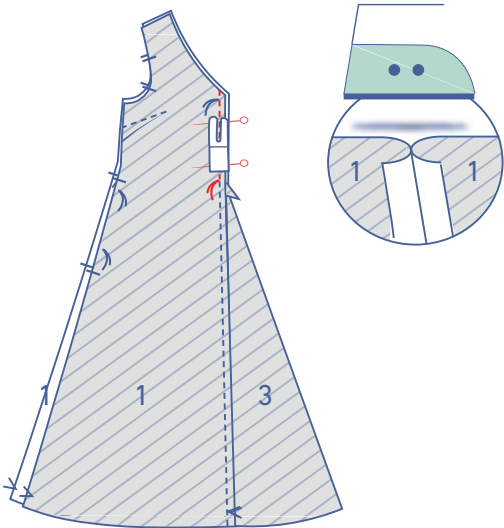

Pin and sew the CF seam from the neckline to the marking thread. Fold the seam allowance of the insert out of the way for this part. Press the seam allowance open.

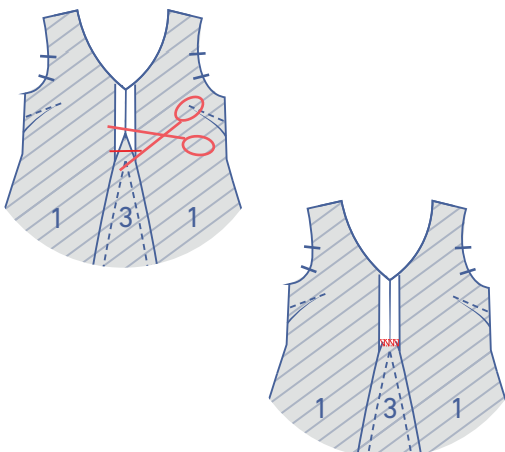

Snip off the triangular part of the seam allowance of the insert above the marking thread. Finish with overlocking.

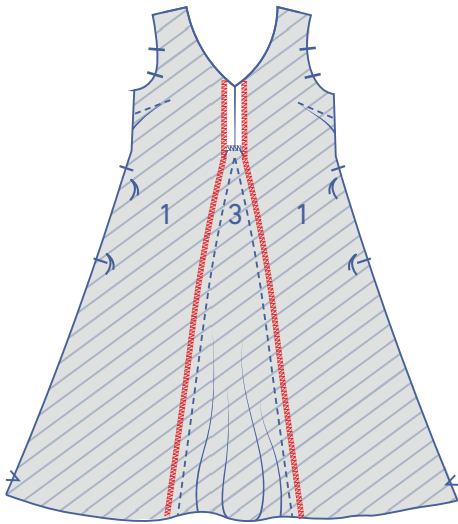

Finish the indicated edges from neckline to hem in one go with an overlock stitch. Above the marking thread, you only finish the raw edges of a single layer of fabric, while below the marking thread, you finish the raw edges of the front and insert together with an overlock stitch.

3

Fold the back (2) in half lengthwise at the V notches with the right side of the fabric facing each other.

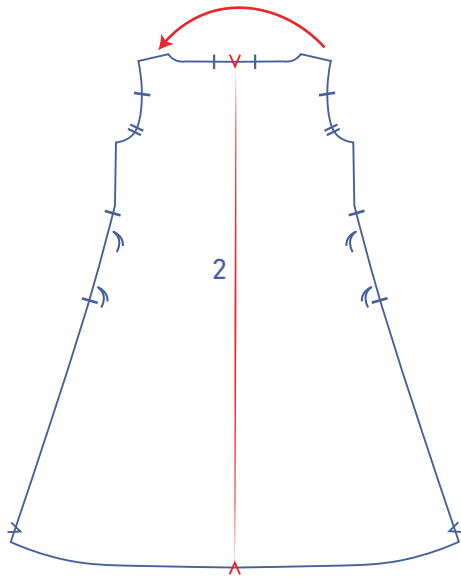

Match the single notches and sew into place with a 4" vertical line.

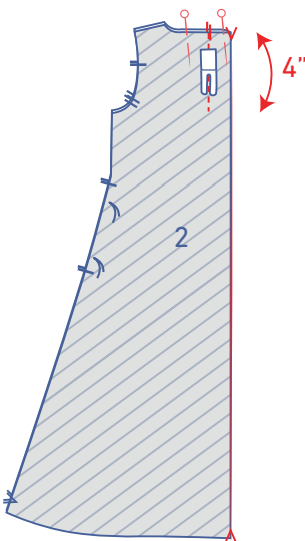

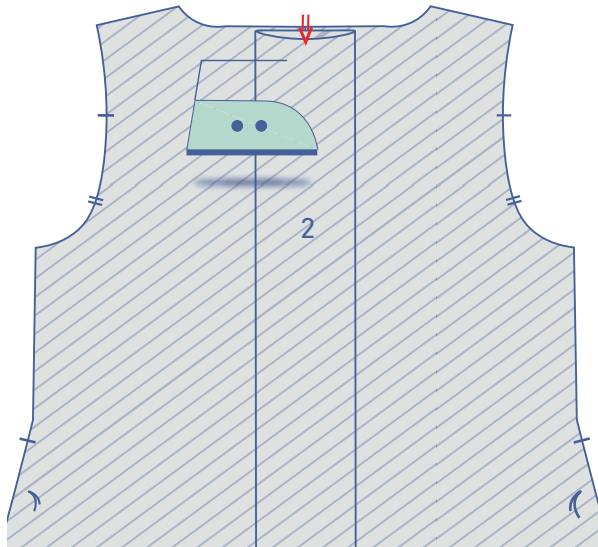

Press the pleat allowance flat so that the V notch lines up evenly with the single notches.

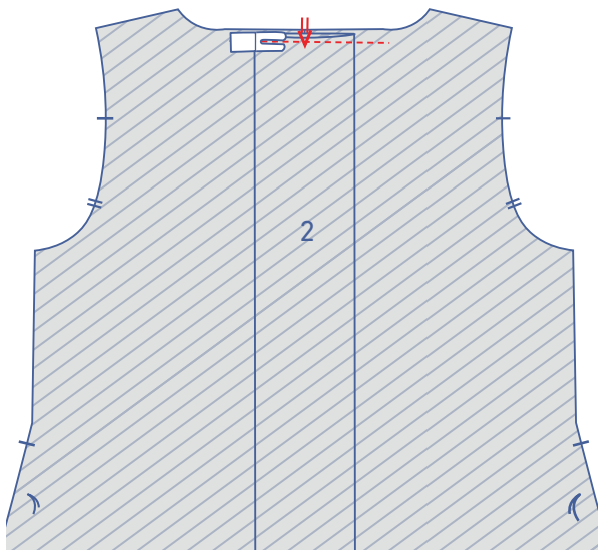

Sew the pleat allowance into place right next to the edge.

4

Pin and sew the shoulder seams together.

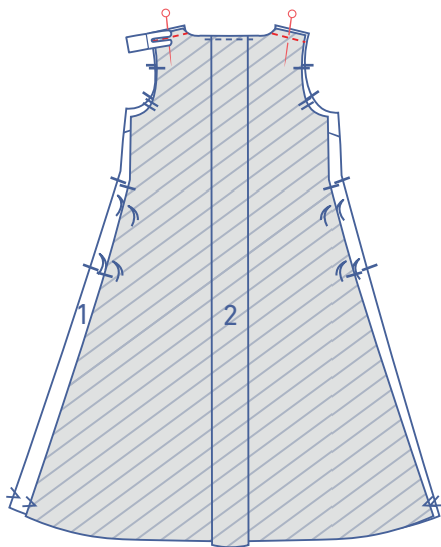

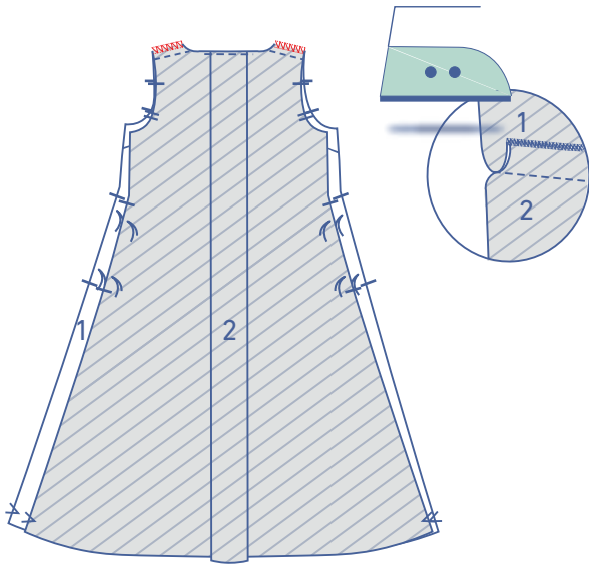

Finish the raw edges with overlock stitching. Press the seam allowance towards the front.

5

Pin and sew the shoulder seams of the front facing (7) and back facing (8) together.

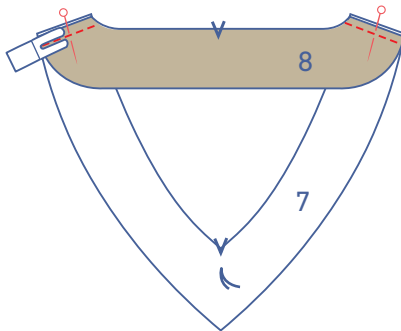

Finish the raw edges with overlock stitching. Press the seam allowance towards the back facing.

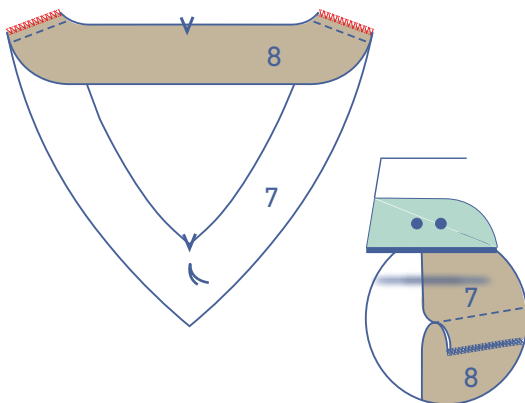

Finish the outer edge of the facing where indicated with overlock stitching.

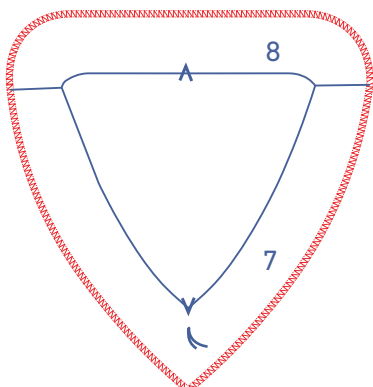

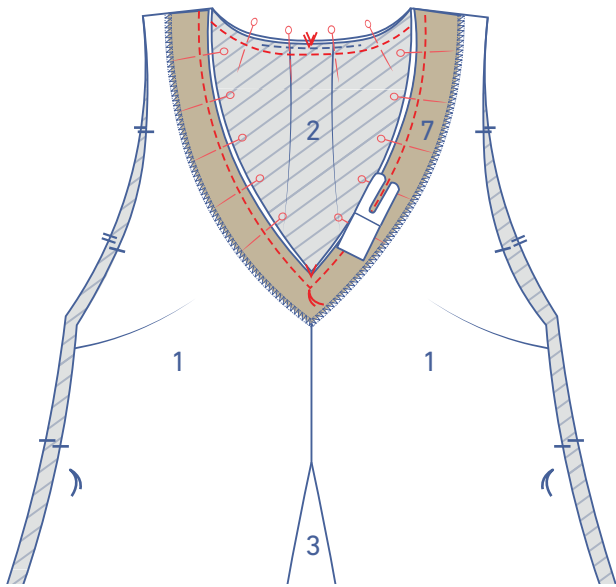

Pin the facing to the dress neckline, right sides together, and sew.

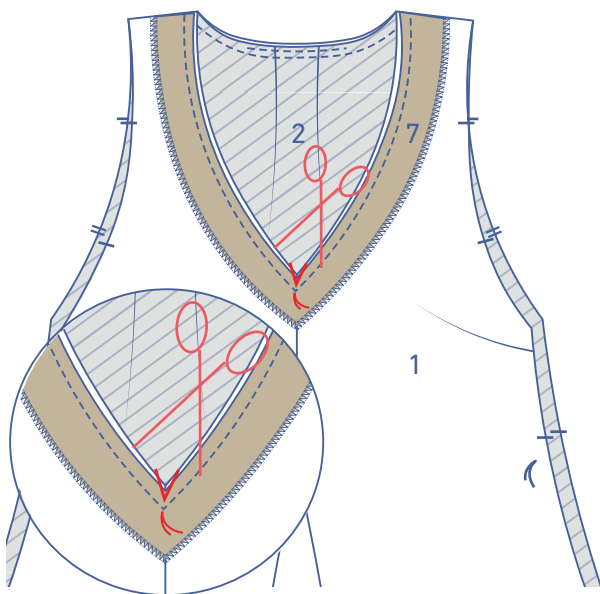

Snip into the seam allowance at the apex of the V until just before the marking thread. This enables the facing to lie flat later on.

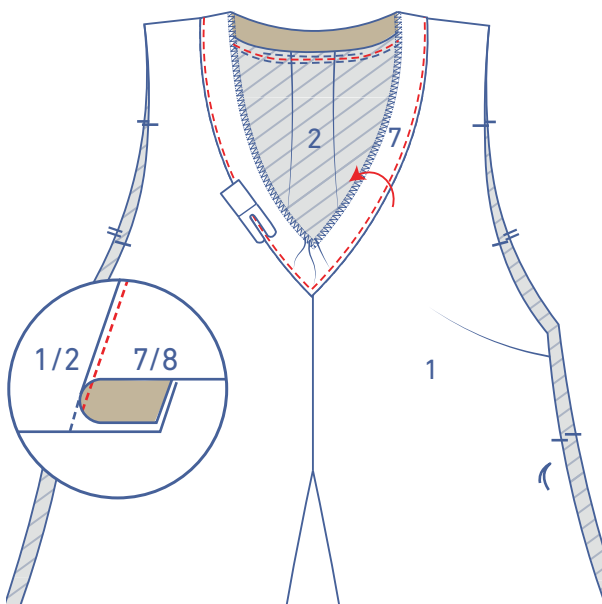

Fold the facing and seam allowance over and sew the facing to the seam allowance underneath, right next to the seam.

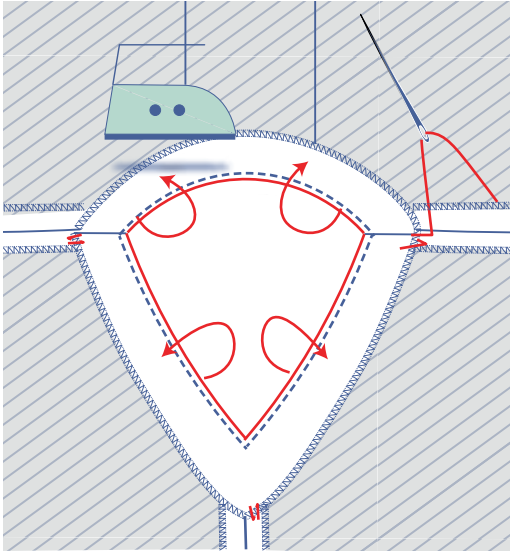

Press the facing neatly to the wrong side. Secure the facing to the CF and shoulder seams by hand with just a few stitches.

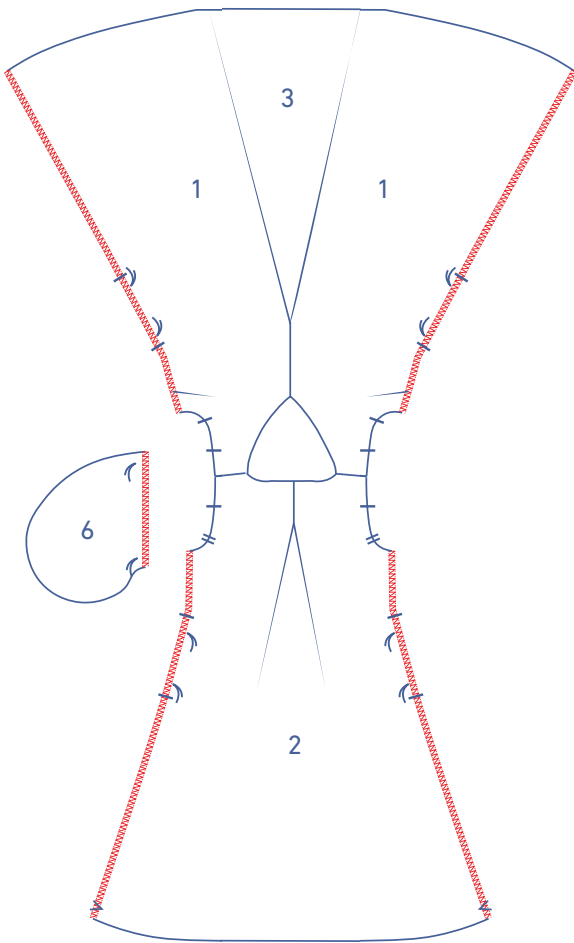

6

Finish the sides of the front and back and the straight ends of the pocket (6) with overlock stitching.

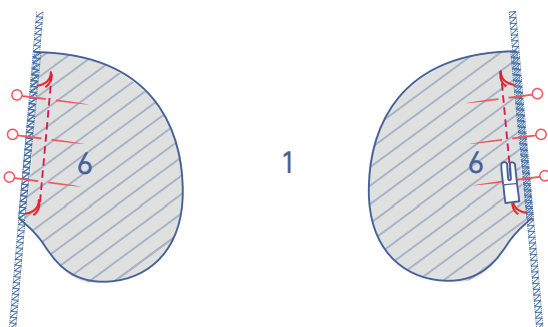

Pin the straight ends of 2 of the 4 pocket pieces to the front with the marking threads matching, right sides together. Sew into place between the marking threads.

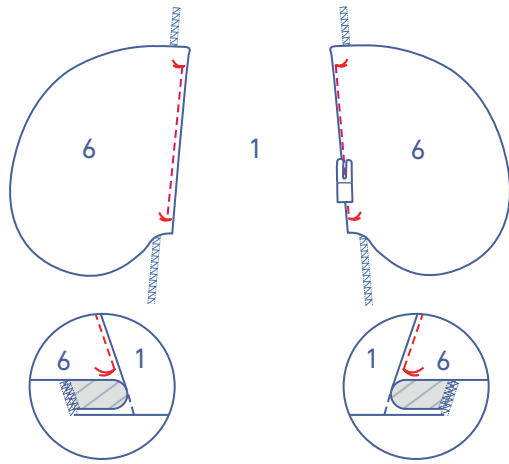

Fold the pocket and seam allowance over and sew the pocket to the seam allowance underneath between the marking threads (= understitch).

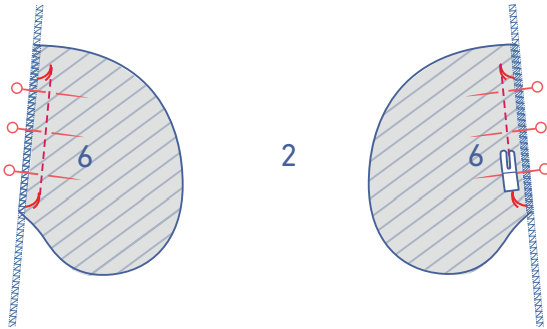

Pin the straight ends of the 2 remaining pocket pieces to the back, matching the marking threads. Sew into place between the marking threads. Do not understitch.

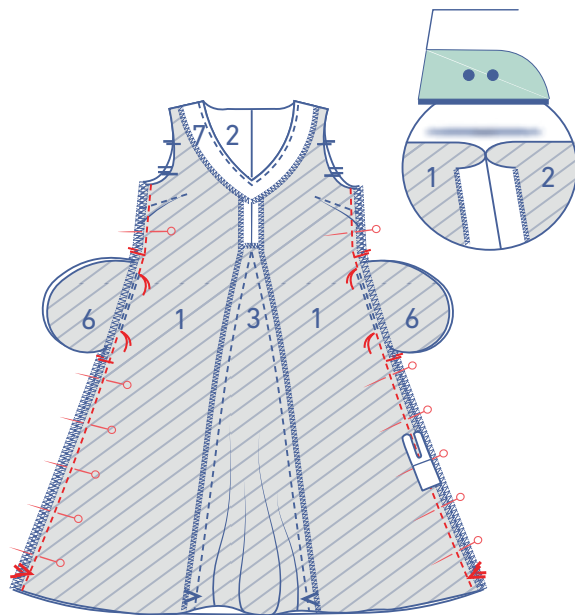

Pin and sew the side seams from the underarm down to the marking threads that mark the top of the pocket opening. Now, sew from the next marking thread to the hem. Press the seam allowance open.

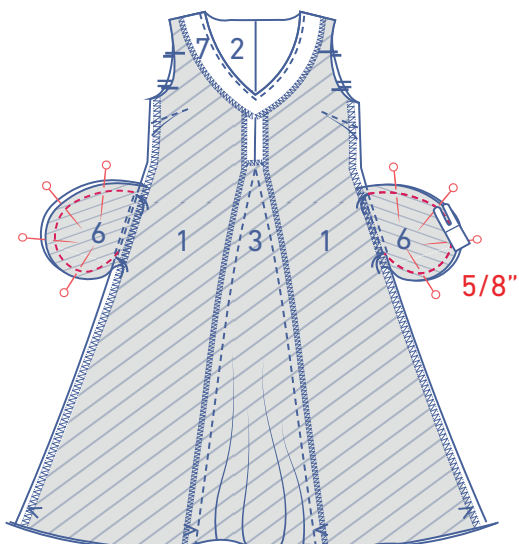

Pin and sew the contours of the pocket pieces together at $\frac{5}{8}$ ".

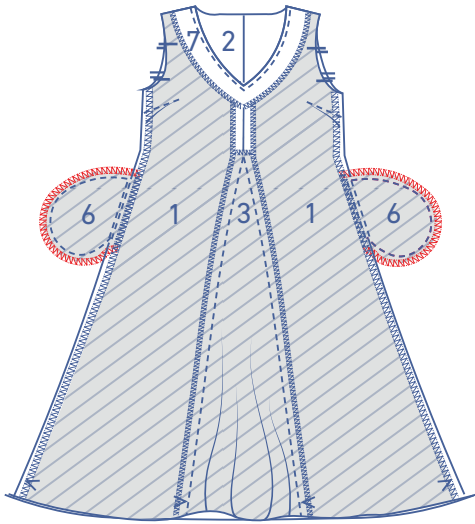

Finish the raw edges with overlock stitching.

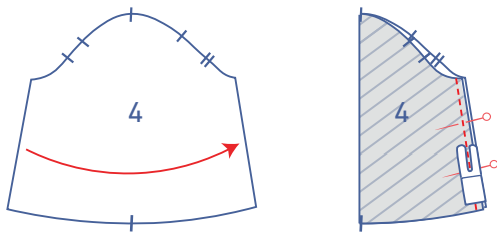

7

Fold the sleeve (4) in half with the right sides of the fabric facing and sew the sides together. Press the seam allowance open.

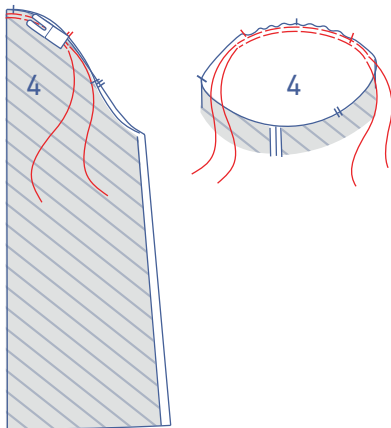
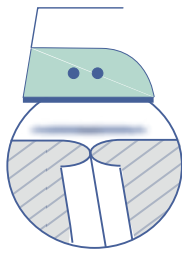

Using a long stitch length at a low thread tension, sew two lines of parallel stitching at the top of the sleeve until just past the indicated single notches. Leave a length of thread at the start and end of the stitching.

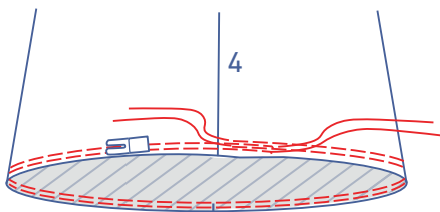

Sew two parallel lines at the bottom of the sleeve using a long stitch at a low thread tension. Leave a length of thread at the start and end of the stitching.

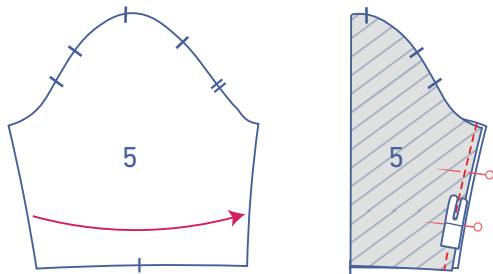

Fold the inner sleeve (5) in half with the right sides of the fabric touching and sew the straight sides together. Press the seam allowance open.

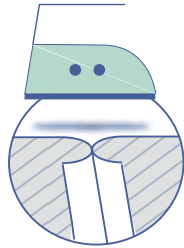

Slide the inner sleeve into the outer sleeve, so that the hemlines are aligned, and the right sides are touching.

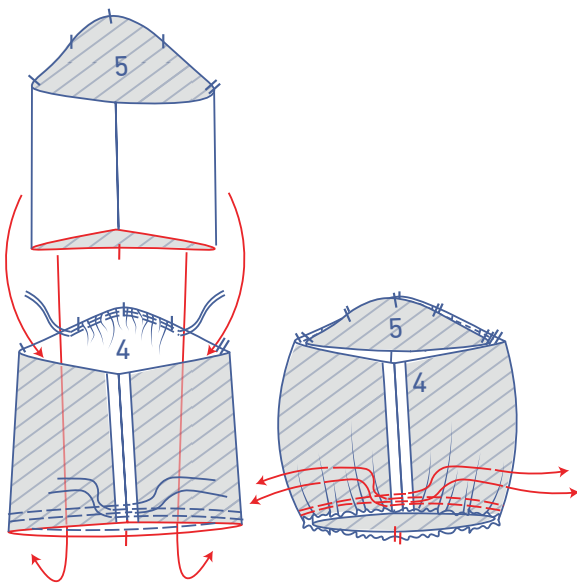

Now, carefully tug the ends of the outer sleeve hem's gathering threads to gather the fabric. Distribute the gathers until the notches in both sleeves match.

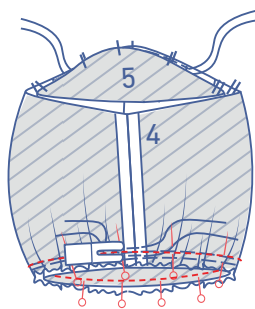

Pin and sew into place.

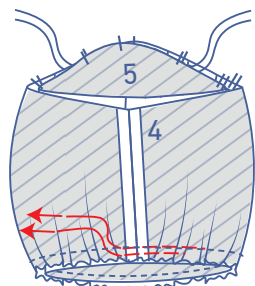

Remove the gathering threads.

Turn the right way out so that the right sides of the sleeve are visible.

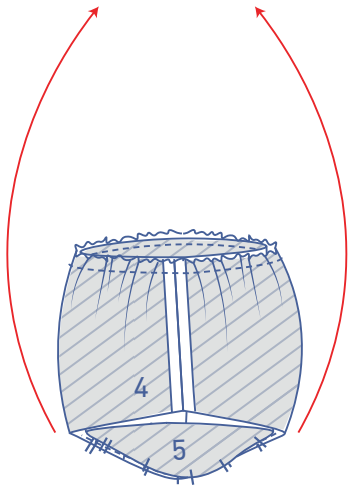

Carefully tug the ends of the gathering threads at the top of the sleeve to gather the fabric. Distribute the gathers until the notches in both sleeves match.

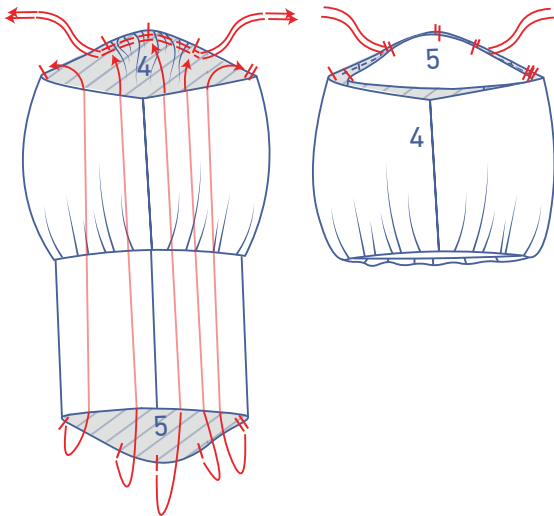

Pin and sew the top of both sleeves to the armhole, matching the notches. The single notch marks the front, while the double notch marks the back. The single notch at the top aligns with the shoulder seam.

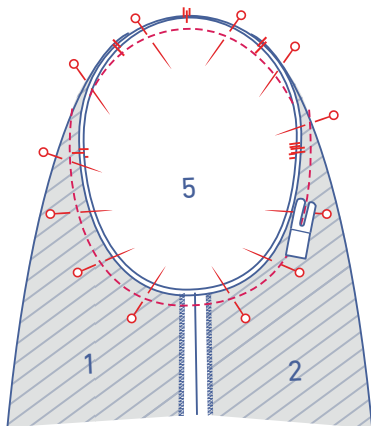

Remove the gathering threads.

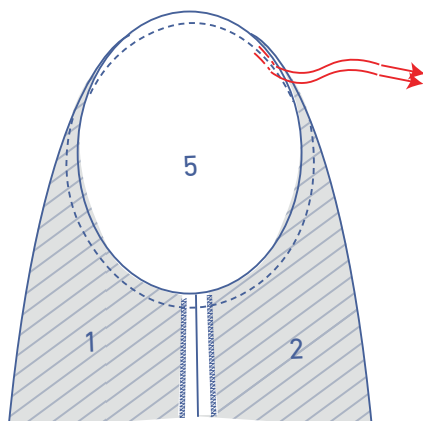

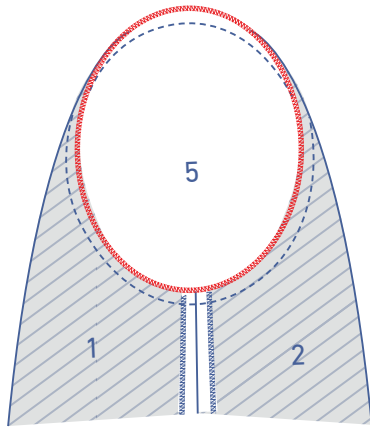

Finish the raw edges together with overlock stitching.

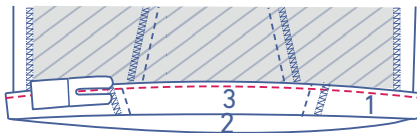
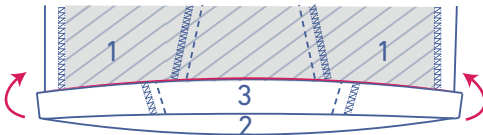
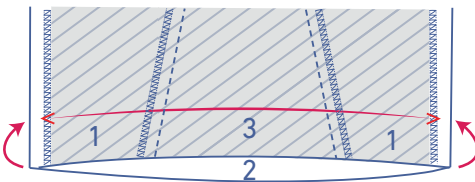
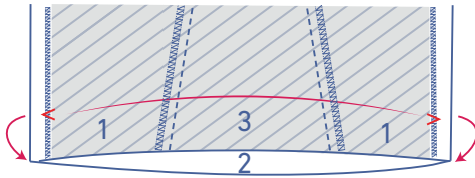
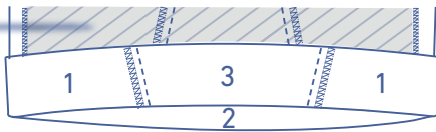
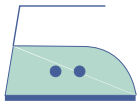

8

Press the hem allowance over at the V notches.

Open back out.

Match the raw edge to the pressed fold line.

Fold over again.

Sew the hem allowance into place right next to the edge.