

# Doris by Fibre ⚡ood



# Doris by Fibre ood



0 - 28

The right dress can make the day, and Doris will give you immaculate style. The statement sleeves of this simple straight dress with round neckline are sure to turn heads. The sleeves are double layered and the shorter inner sleeve pulls the outer sleeve in, creating a balloon effect. A few other details worth mentioning? Bust darts, a handy slit in the centre back seam for walking comfort ... pop the dress over your head and you're ready to go! The length is up to you, and the belt is optional.

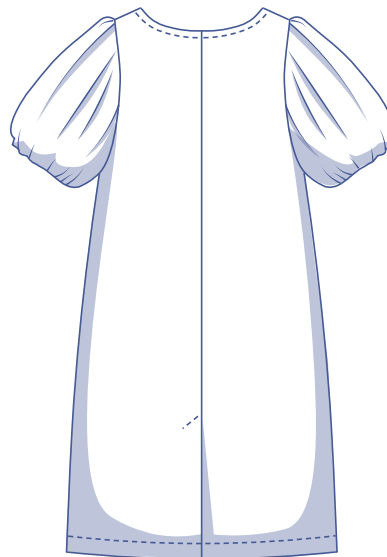
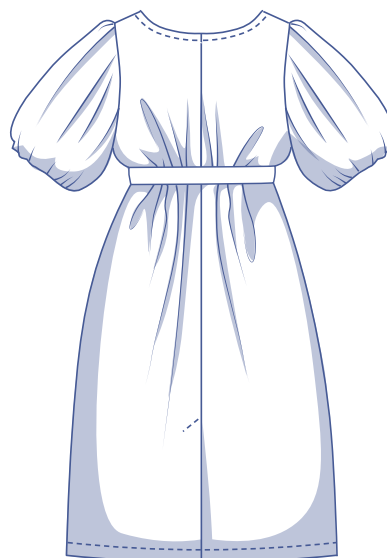
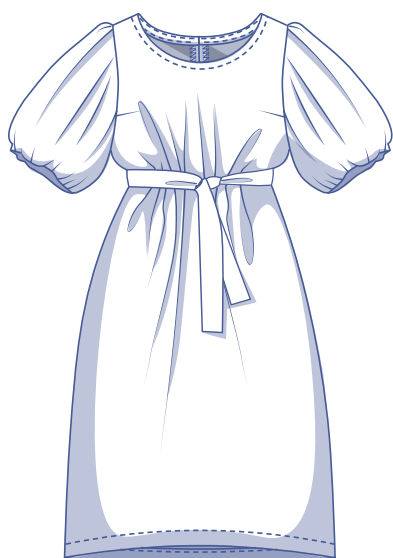

## size chart (in inches)

size	0	2	4	6	8	10	12	14	16	18	20	22	24	26	28
H (height)	5'25"	5'38"	5'45"	5'48"	5'51"	5'54"	5'58"	5'61"	5'64"	5'64"	5'64"	5'64"	5'64"	5'64"	5'64"
B (bust)	29.9	31.5	33.1	34.6	36.2	37.8	39.4	40.9	43.3	45.7	48	50.4	52.8	55.1	57.5
W (waist)	26	26.8	27.6	29.1	30.7	32.3	33.1	34.6	37.2	39.8	42.3	44.9	47.4	50	52.6
H (hips)	33.9	35.4	37	38.2	39.4	40.6	41.7	42.9	45.3	47.2	49.2	51.2	53.1	55.1	57.1

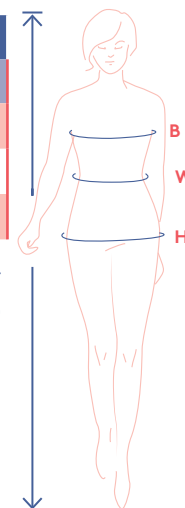

Choose your size based on your **bust measurement**. If your waist and hip measurements are wider than those in the size chart, check the size chart below to see if there is enough room or whether the pattern needs to be altered. It's easy to do. Simply trace the line of the one size instead of the other.

## pattern measurements (in inches)

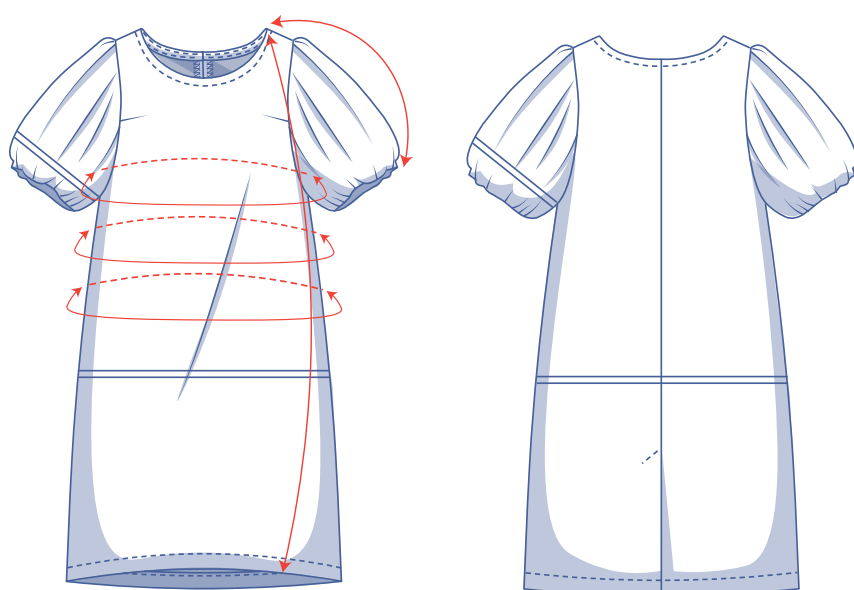

== shorten or lengthen the pattern here

This chart's measurements are the pattern measurements based on the fabric type and serve as a reference. Ease has been added to the width measurements (in addition to the exact body measurements) for a more comfortable fit. Doris is designed to have a **relaxed** cut.

size	0	2	4	6	8	10	12	14	16	18	20	22	24	26	28
length	44.9	45.1	45.3	45.5	45.7	45.9	46.9	47.2	48.7	49	49.3	49.6	49.9	50.2	50.5
sleeve length*	16.2	16.4	16.6	16.8	16.9	17.1	17.3	17.5	18	18.3	18.5	18.7	18.9	19.1	19.4
bust	33.5	35.1	36.7	38.3	39.8	41.4	43	44.6	46.9	49.3	51.6	54	56.4	58.7	61.1
waist	34.2	35.8	37.3	38.9	40.5	42.1	43.6	45.2	47.6	49.9	52.3	54.7	57	59.4	61.7
hips	35.3	36.9	38.5	40	41.6	43.2	44.8	46.3	48.7	51.1	53.4	55.8	58.2	60.5	62.9

\* Including shoulder length.

Compare the stated lengths to the measured or desired lengths. **Lengthen** or **shorten** the dress and/or the sleeves by cutting the pattern pieces at the indicated double lines. Then either increase the distance between the cut pieces by the desired amount (to lengthen) or overlap the pieces (to shorten). Make sure that the CF and CB lines and the side seams are always straight.



### IMPORTANT

Adjust the amount of fabric to be used based on these alterations.

## notions



- Thread
- Iron-on interfacing: max. 1/2 yd
- Fabric: see table

fabric		0	2	4	6	8	10	12	14	16	18	20	22	24	26	28
fabric width 43"	yd	3 1/4	4 1/4	4 1/4	4 1/4	4 1/4	4 1/4	4 1/2	4 1/2	4 1/2	4 3/4	4 3/4	4 3/4	5 1/4	5 1/4	5 1/4
fabric width 55"	yd	3	3 1/4	3 1/4	3 1/4	3 1/4	3 1/4	4	4	4	4 1/4	4 1/4	4 1/2	4 1/2	4 1/2	4 1/2

The corresponding fabric layout can be found on page 6 of these sewing instructions.

## fabric advice



Doris looks lovely in a whole range of different fabrics, from lightweight fluid drape fabrics to more structured, heavyweight fabrics. Choose the fabric based on the look you hope to achieve. Drama-lovers might opt for corduroy, denim, poplin, or leather. For the a more reserved look, something more understated will work, i.e. fabric with a fluid drape and without much texture such as viscose (crepe), lyocell, satin, etc. Solid or print? The sky's the limit with Doris.

# Proud to be #Sewista

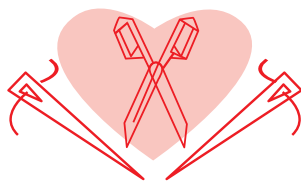



**fabric layout – solid fabrics**  
**fabric width 43"**

0

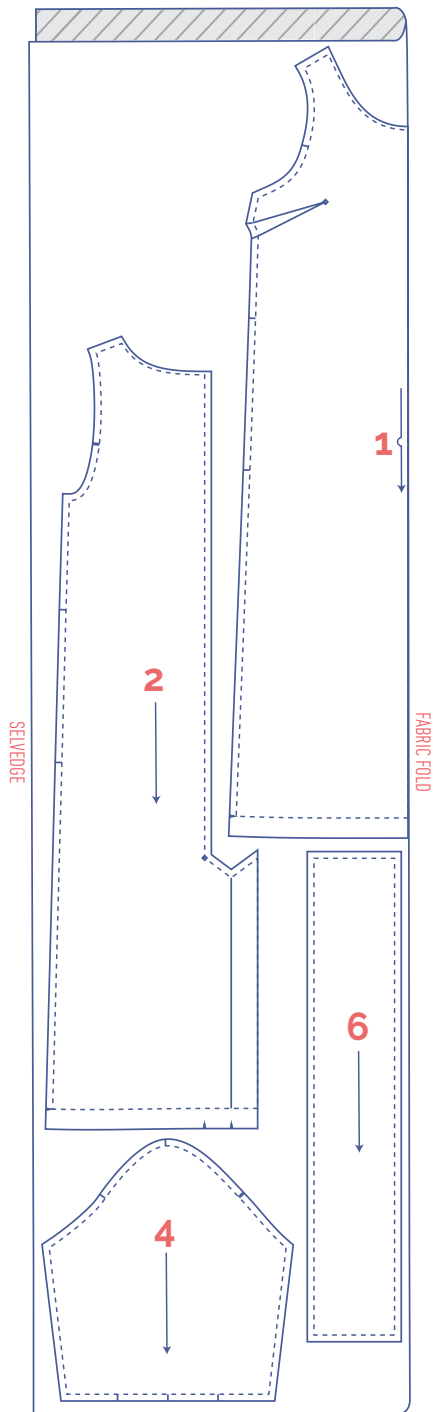

+

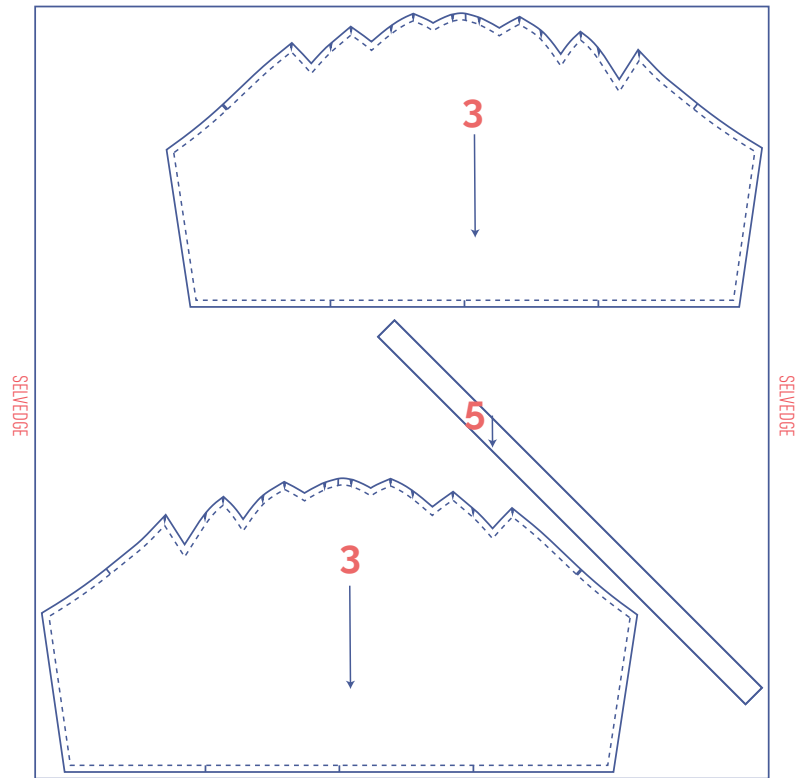

**fabric layout – solid fabrics**  
**fabric width 43"**

2 - 22

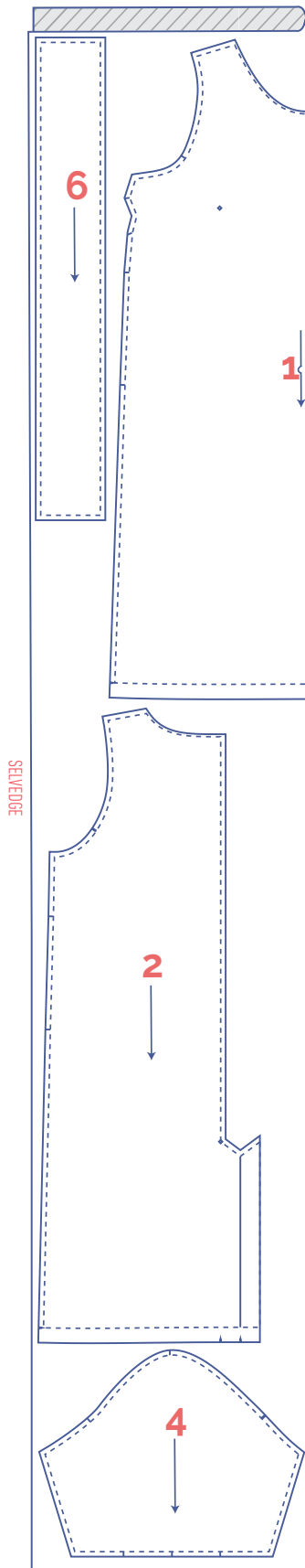

+

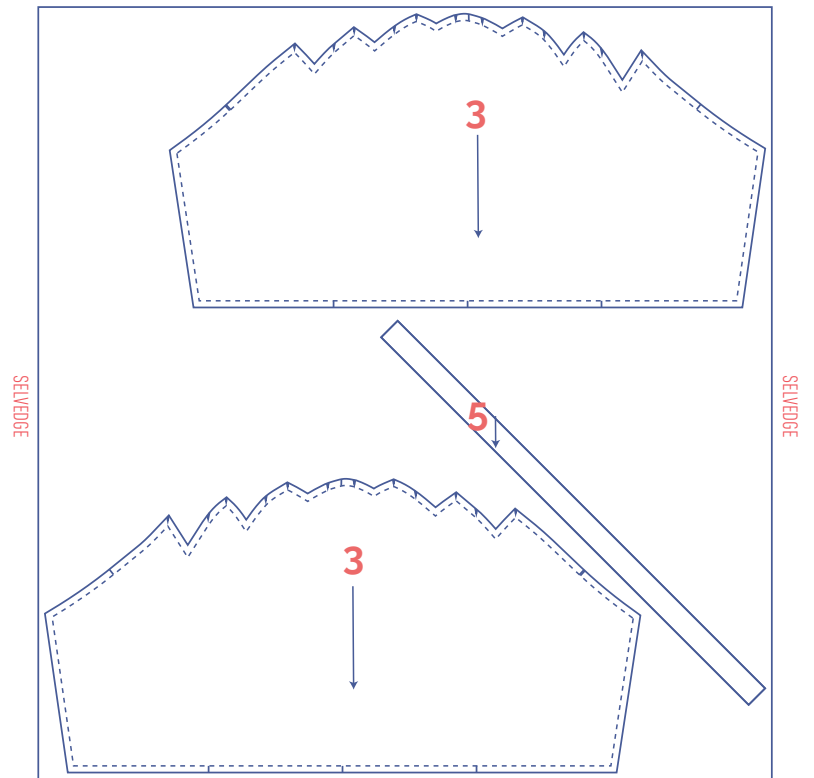

**fabric layout – solid fabrics**  
**fabric width 43"**

24 - 28

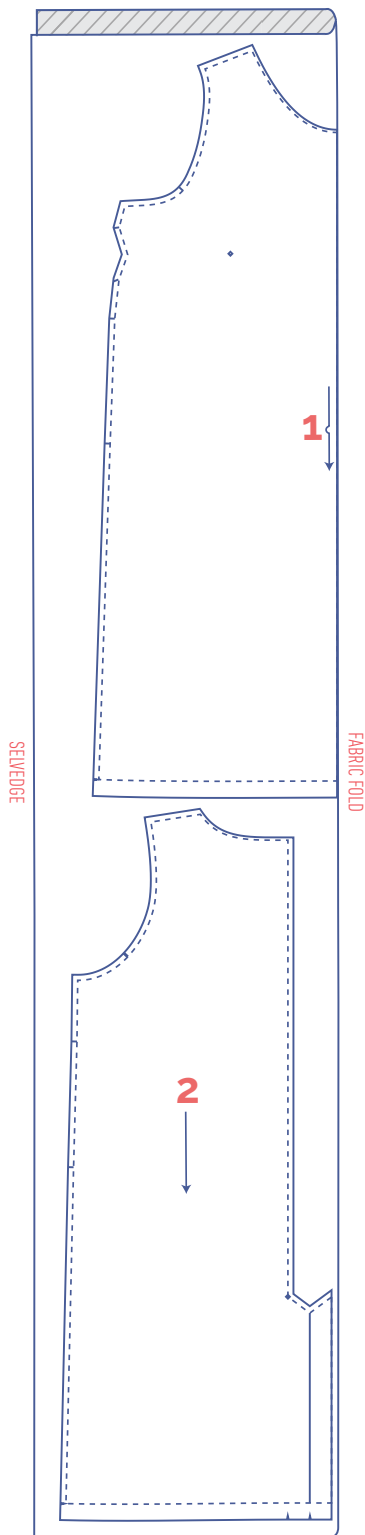

+

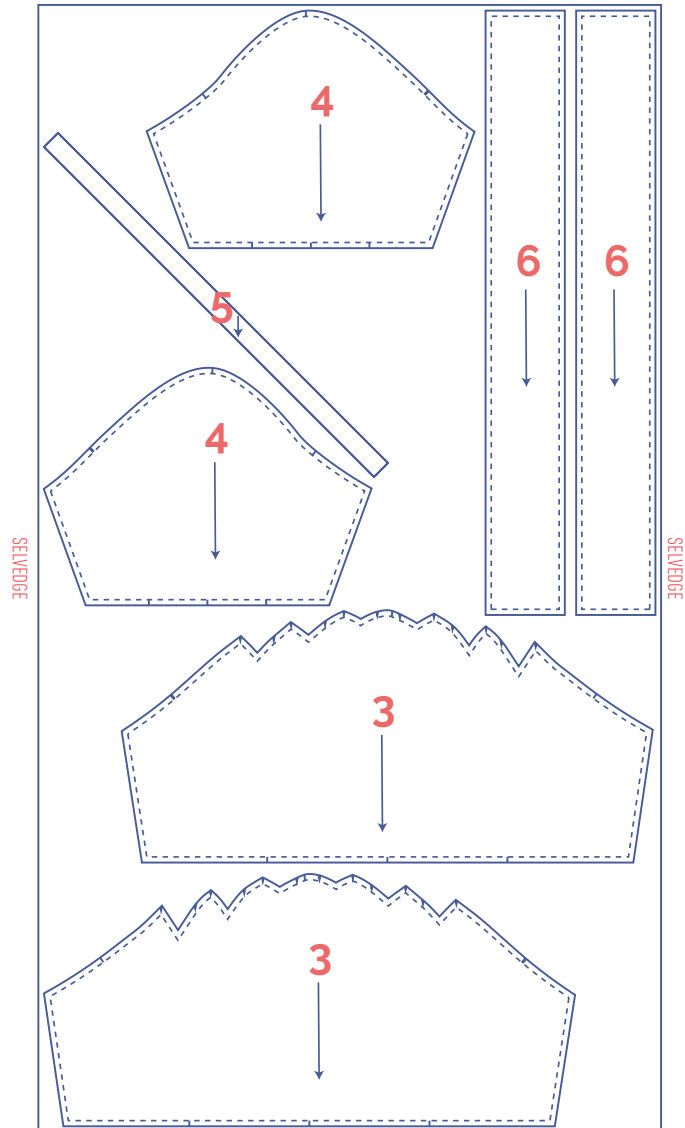



**fabric layout – solid fabrics**  
**fabric width 55"**

0 - 10

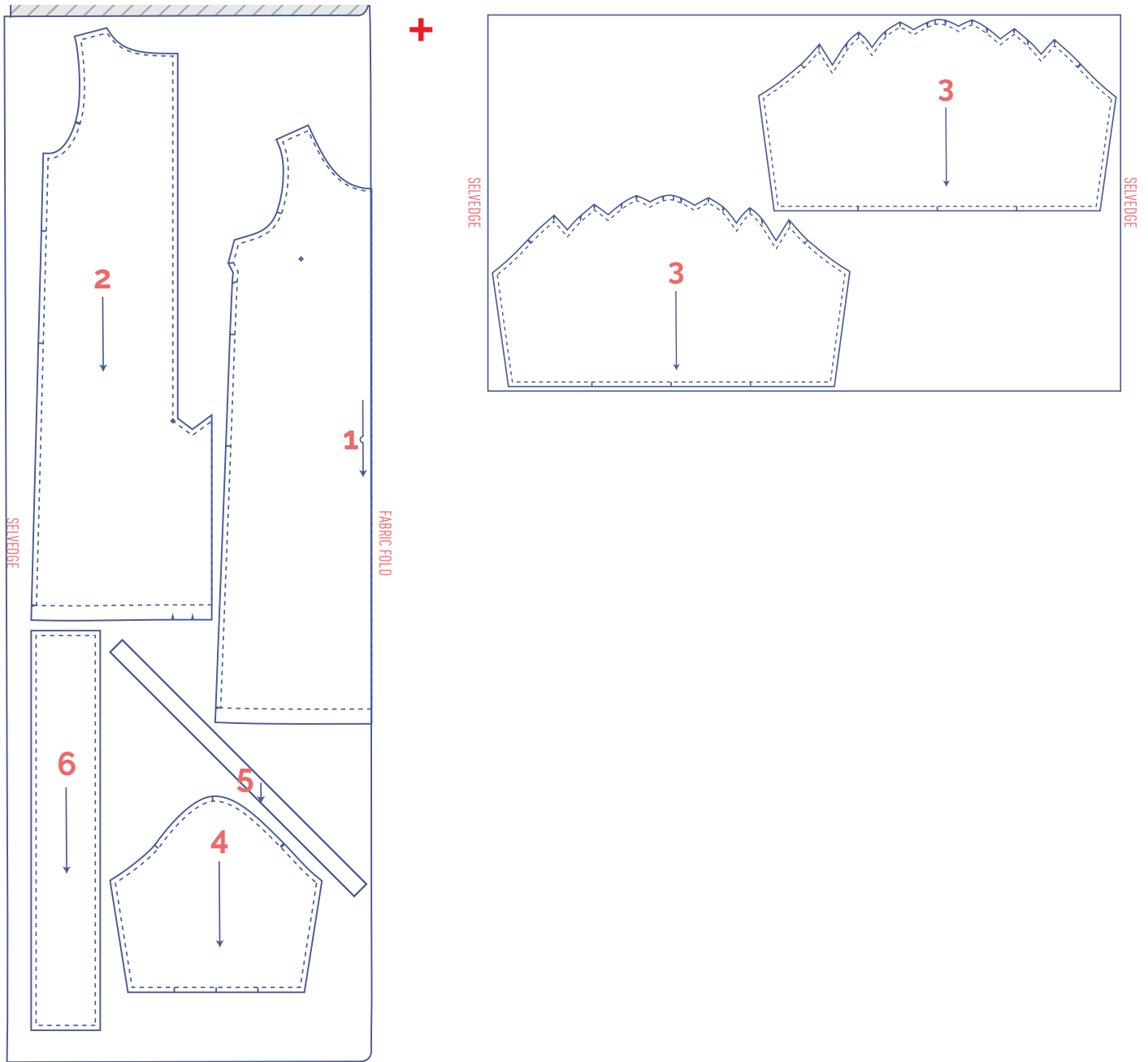

**IMPORTANT**

You only need pattern piece 5 once.

**fabric layout – solid fabrics**  
**fabric width 55"**

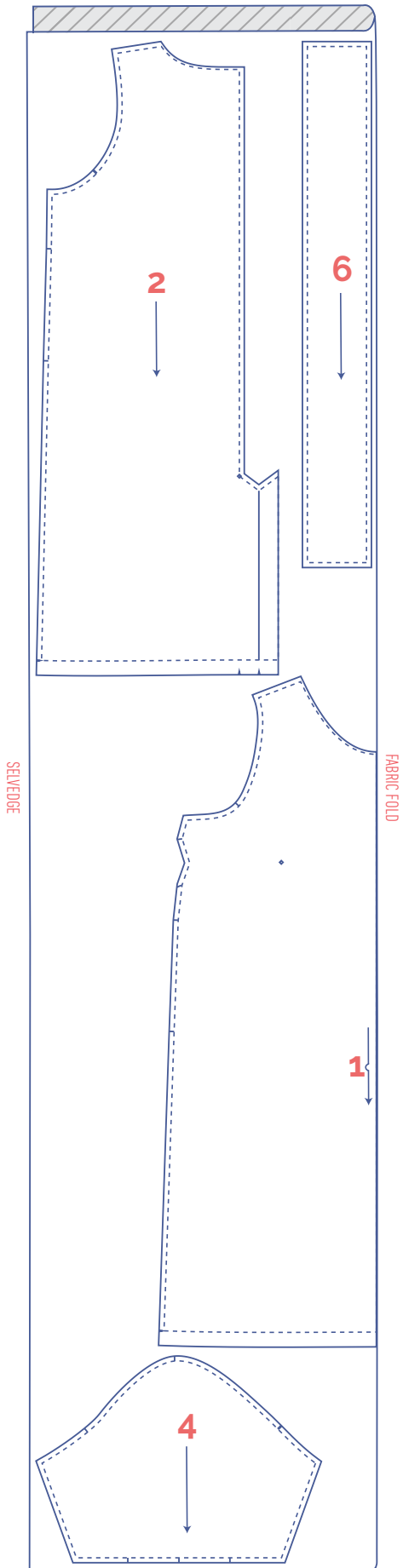

12 - 28

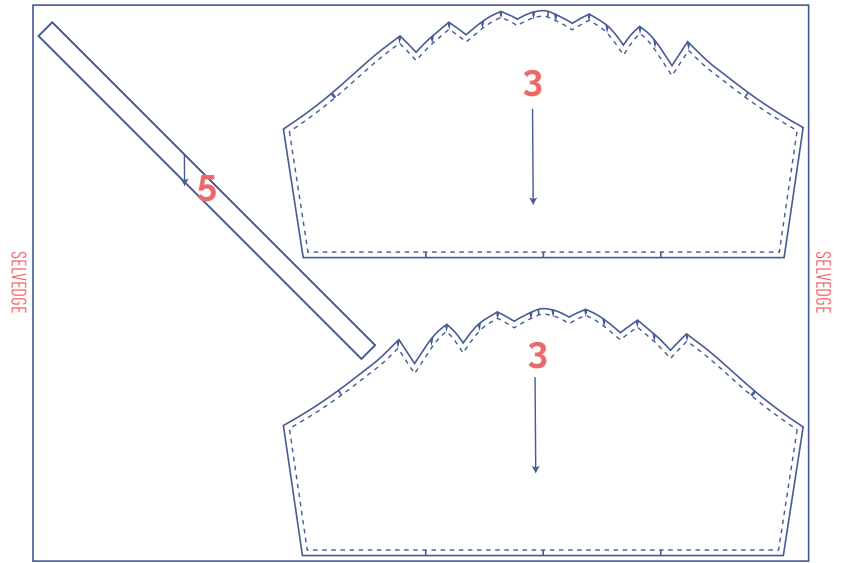

+



**marking pattern pieces**

	Notch the pattern paper and fabric at the following points
	single notch
	double notch
V	V notch
	mark the following points with marking thread
	centre point

# sewing instructions



The method used to finish the seams depends on the fabric used. The pieces are always sewn together with the right sides of the fabric facing, unless stated otherwise.

F front

B back

RB right back 

LB left back 

CF centre front

CB centre back

 right side

 wrong side

 iron-on interfacing

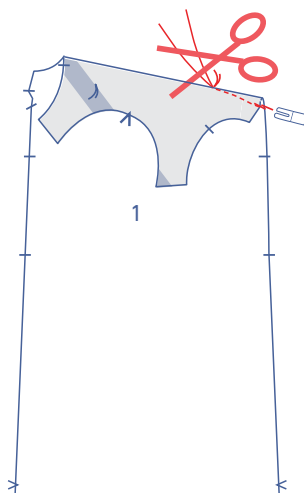
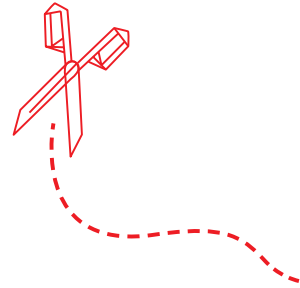

## 1

Match the notches in the side seam of the front (1) together with the right sides of the fabric facing. Stitch the dart in a slightly curved line towards the marking thread. Stitch up to and just past the marking thread, so that you've sewn past the fabric. Snip the threads and make a knot.

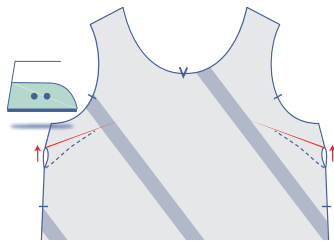

Turn the front over so that the right side is facing down. Press the bust or French dart up.

Finish the indicated sides with overlock stitching.

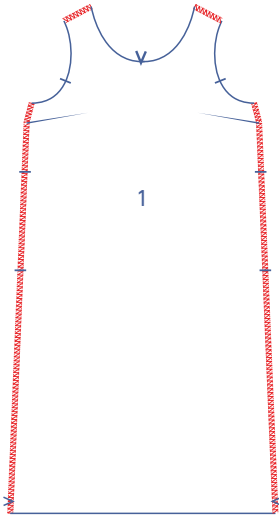

---

## 2

Place both back (2) pieces in front of you with the right sides facing up. Cut a piece of the slit facing from the LB on the illustrated cutting line.

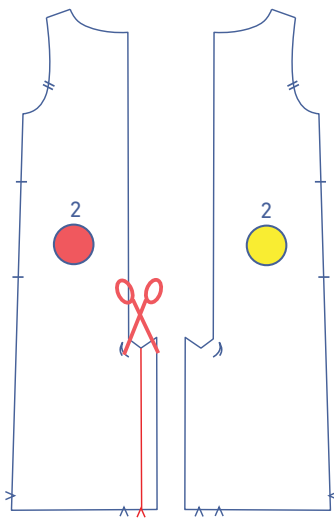

Finish the shoulders, sides, and straight ends of the facing with overlock stitching.

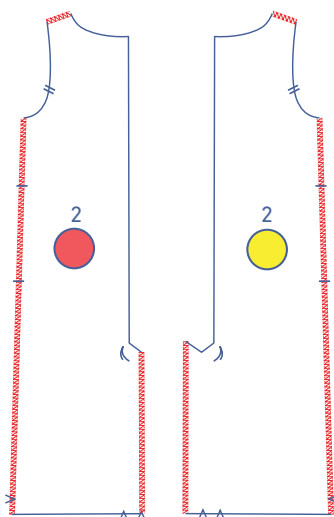

Fold the facing of the RB over towards the right side of the RB at the V notch as indicated.

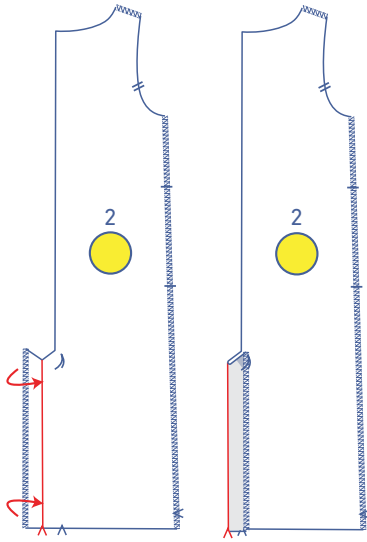

Stitch horizontally into place at 1 1/4" above the hem.

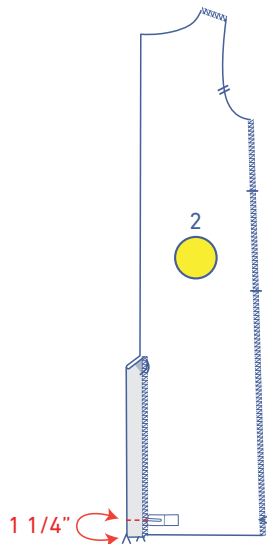

Fold the facing towards the wrong side.

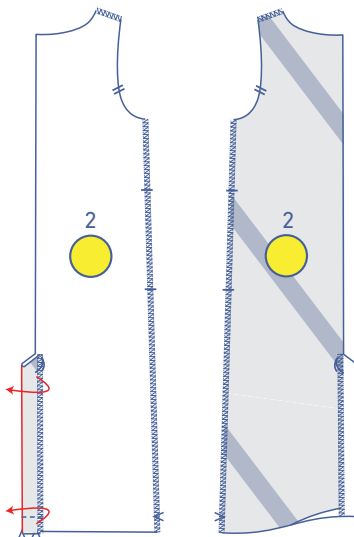

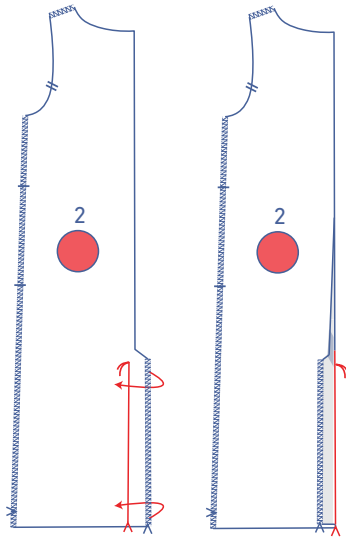

Fold the facing of the LB over towards the right side of the LB at the V notches indicated in the hem.

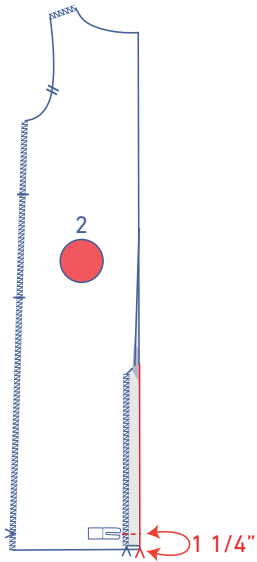

Stitch horizontally into place at 1 1/4" above the hem.

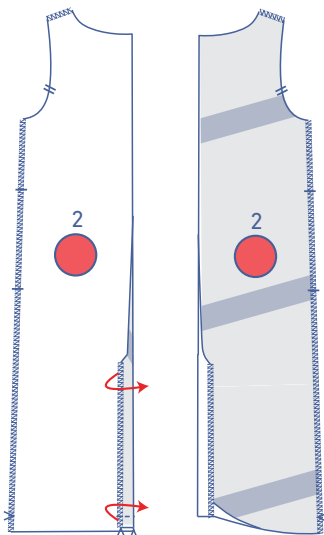

Fold the facing towards the wrong side.

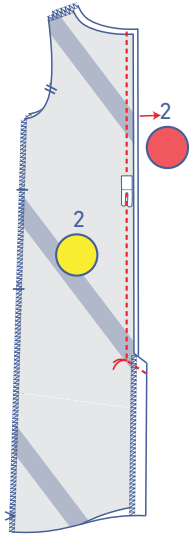

Pin and sew the CB seams and the slanted edge of the slit as shown.

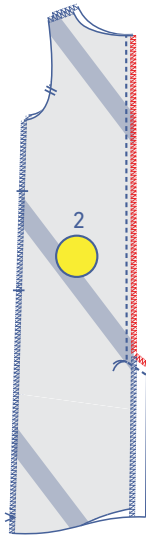

Finish the raw edges together with overlock stitching.

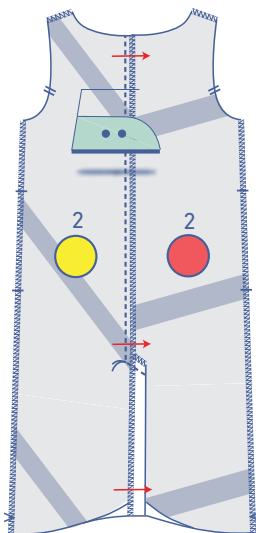

Press the seam allowance and the slit towards the LB.

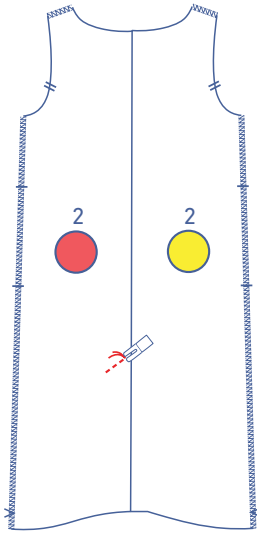

Stitch a few stitches on the right side of the fabric, anchoring through all layers to join the top of the slit.

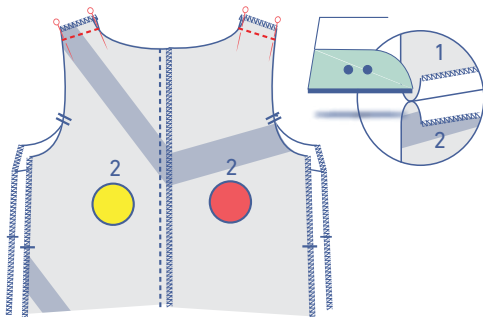

**3**

Pin and stitch the shoulder seams. Press the seam allowances open.

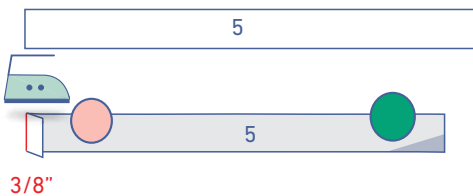

**4**

Press 1 short end of the bias tape neck (5)  $\frac{3}{8}$ " towards the wrong side.

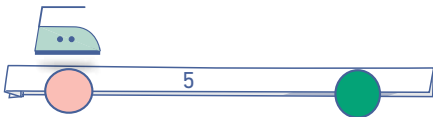

Fold the bias tape in half with the long ends together and the wrong sides of the fabric facing.

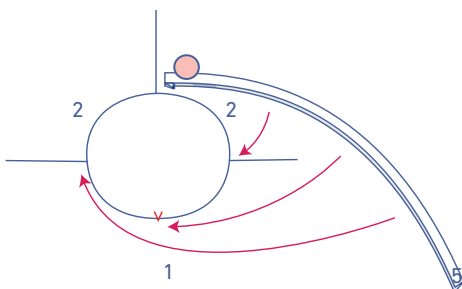

Pin raw edges of the bias tape to the right side of the neckline. The folded end (pink circle) aligns with the CB.



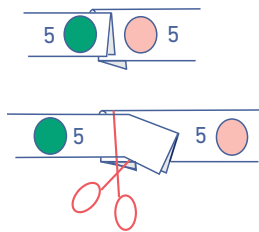

The unfolded end (green circle) of the bias tape should be on top of the folded end. Snip off any excess bias tape. (Providing the exact length is tricky because the grain line is on the bias, i.e. every fabric type is different.) Sew into place at  $\frac{1}{6}$ " from the raw edge.

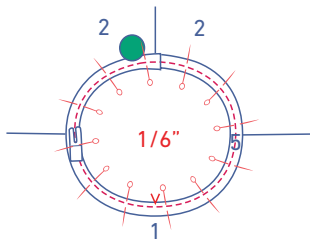

Fold the bias tape and seam allowance over and stitch the bias tape to the seam allowance underneath, right next to the seam.

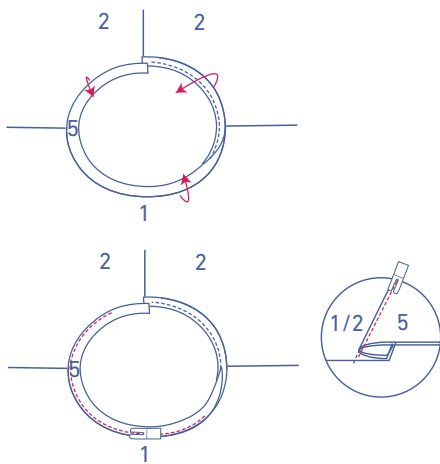

Fold the bias tape all the way over to the wrong side and edgestitch into place.

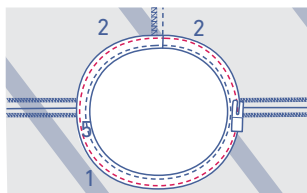

## 5

Pin and sew the side seams together. Press the seam allowances open.

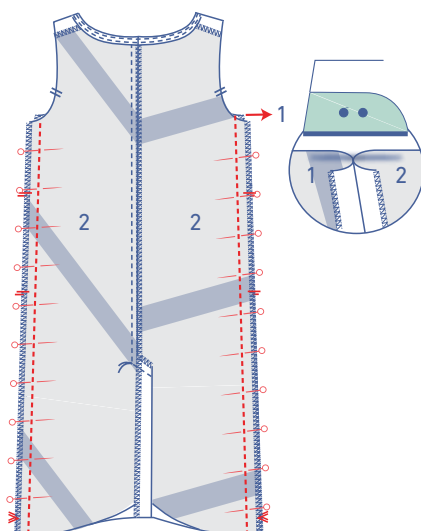

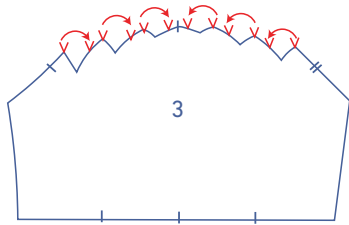

## 6

Make the pleats. Match the pairs of notches on the top of the sleeve (3) as shown, wrong sides of the fabric together.

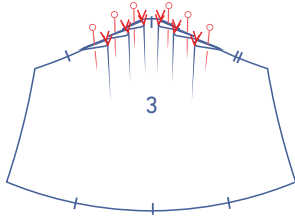

Use a basting stitch to sew the pleats temporarily into place right next to the edge.

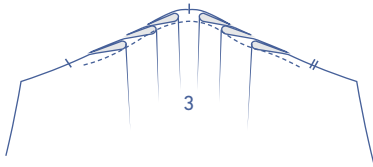
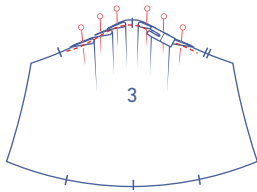

Fold the sleeve in half with the right sides of the fabric facing and sew the sides together. Press the seam allowances open.

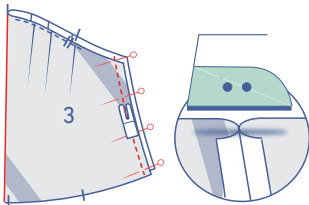
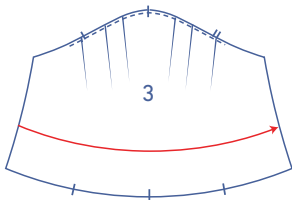

Sew 2 parallel lines of stitching to the bottom of the sleeve using a long stitch length at a low thread tension. Leave a length of thread at the start and end of the stitching.

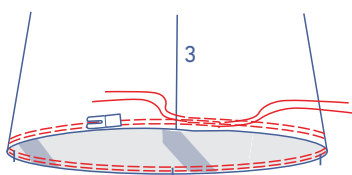

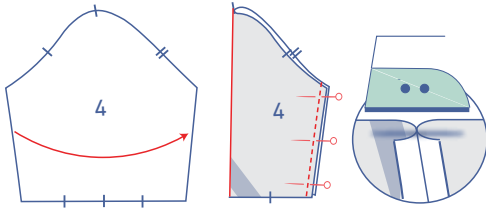

Fold the inner sleeve (4) in half with the right sides of the fabric facing and sew the sides together. Press the seam allowances open.

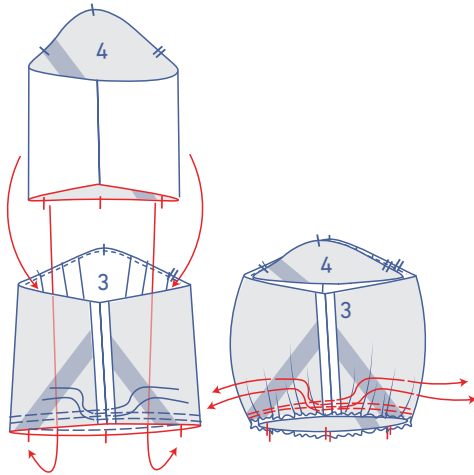

Slide the inner sleeve into the outer sleeve, so that the hemlines are aligned, and the right sides are facing. Now, carefully tug the ends of the gathering threads on the outer sleeve (3) to gather the fabric. Distribute the gathers until the notches in the inner sleeve match those of the outer sleeve.

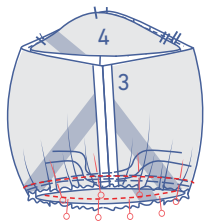

Pin and sew, making sure the seams and notches match.

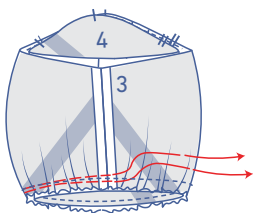

Remove the gathering threads.

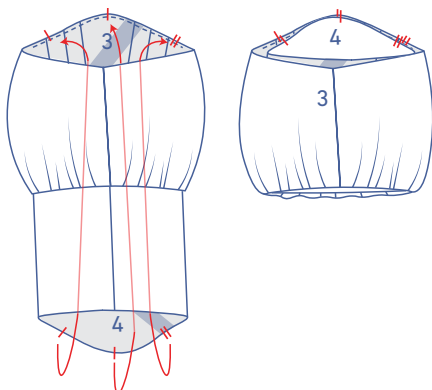

Turn the right way out so that the right sides of the sleeve are visible. Neatly match the notches in both sleeves.

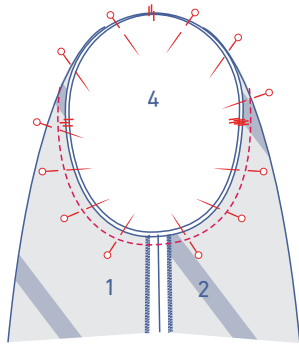

Pin the top of both sleeves to the armhole, matching the notches. The single notch marks the front, while the double notch marks the back. The single notch at the top aligns with the shoulder seam. Distribute the excess fabric between the notches at the top. Stitch into place.

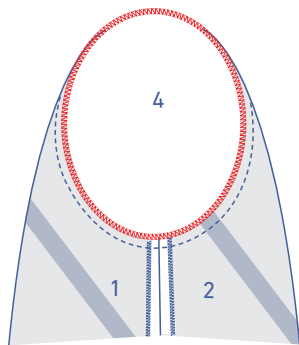

Finish the raw edges together with overlock stitching.

---

## 7

Stitch one side of the belt's (6) short ends together. Press the seam allowance open.

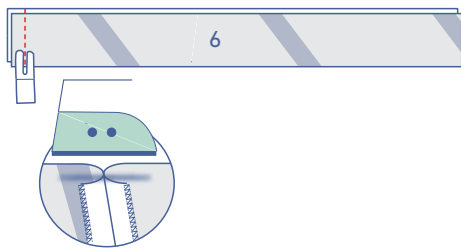

First, open the belt all the way out. Then fold in half with the long ends touching and the right sides of the fabric facing.



Sew the indicated ends, but leave an opening to turn the belt the right way out again.

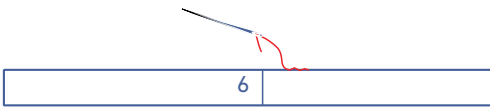

Turn the belt the right way out and sew the opening closed.

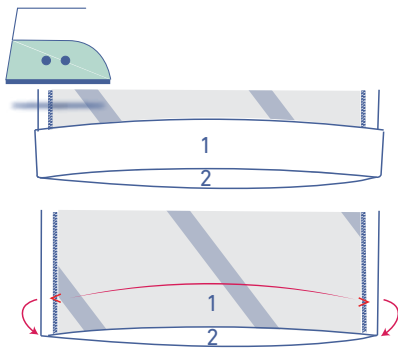

## 8

Press the hem allowance up at the V notches and fold back down.

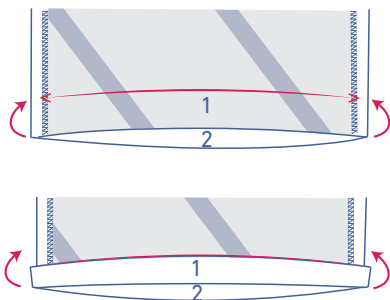

Fold the raw edge down to meet the pressed fold line and then fold again.

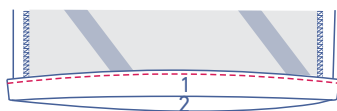

Stitch into place.