

Viva by Fibre ⚡ood



Viva by Fibre ood



XS - XXXL

A minimalist princess dress with darling sleeves and a square neckline. The front and sleeves drape effortlessly from the gathers in the yoke. We made our Viva with a generous flounce at the bottom. But if you prefer a more understated look, simply leave it off. And there's no time wasted fiddling with fastenings – just pull Viva on and go. Viva ... Viva!

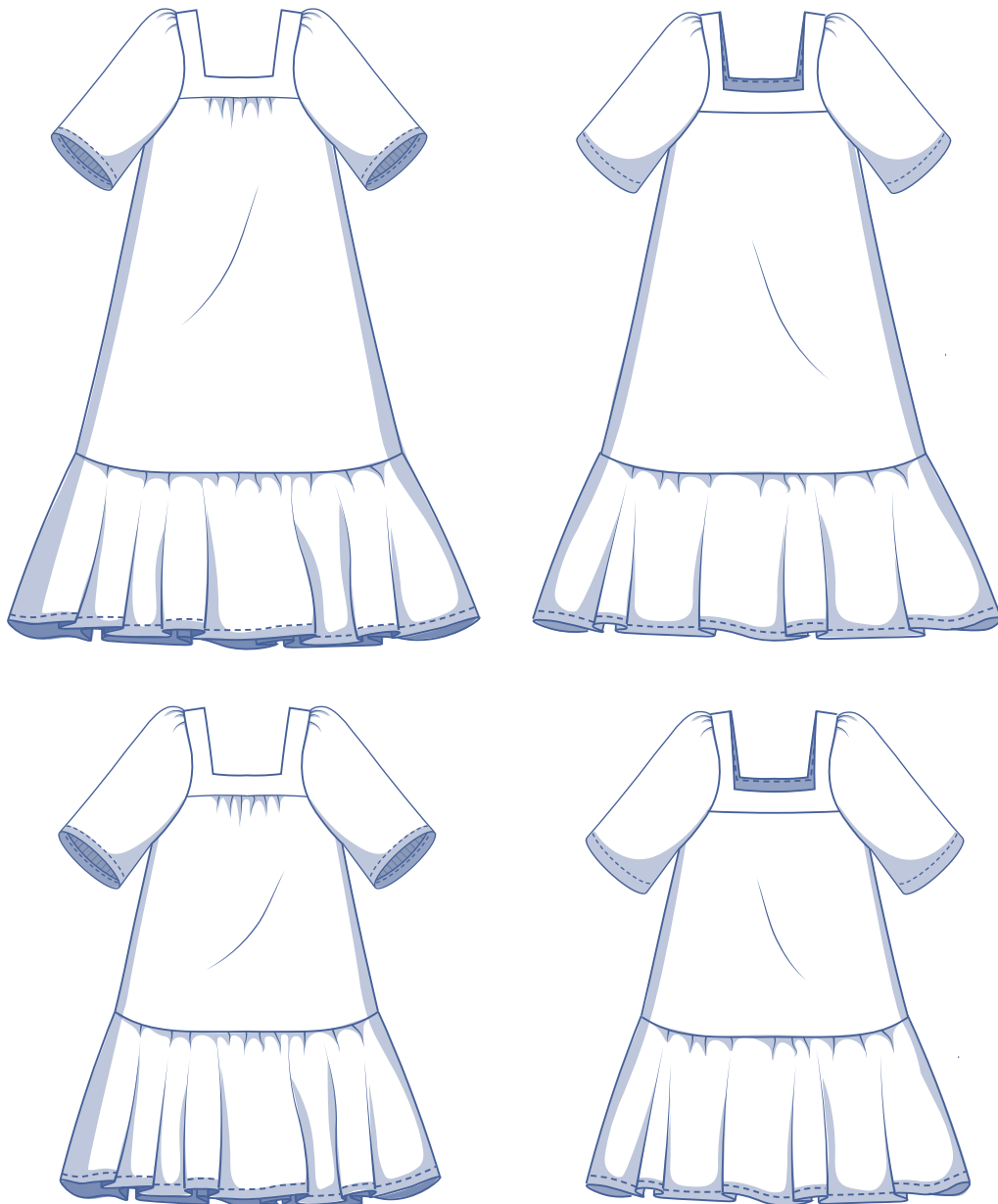

size chart (in cm)

size	XS		S		M		L		XL		XXL		XXXL		
	4	6	8	10	12	14	16	18	20	22	24	26	28	30	32
body height	160	164	166	167	168	169	170	171	172	172	172	172	172	172	172
B (bust)	76	80	84	88	92	96	100	104	110	116	122	128	134	140	146
H (hips)	86	90	94	97	100	103	106	109	115	120	125	130	135	140	145

Choose your size based on your **bust measurement**. Is your hip measurement wider than what's listed in the size chart? If so, check the hip measurements in the chart below to see if there's enough room or whether the pattern size needs to be altered. It's easy to do. When tracing the pattern, simply trace from the line of one size to the line of the other.

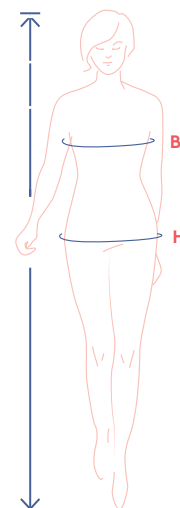

pattern measurements (in cm)

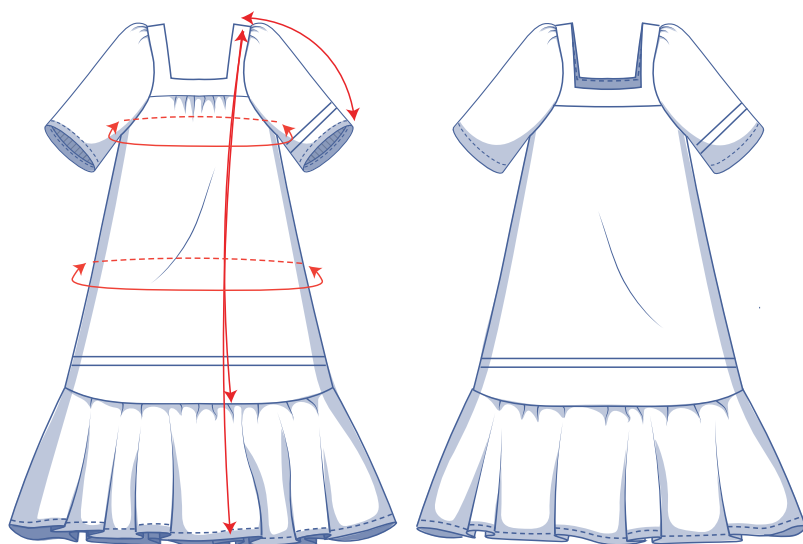

== shorten or lengthen the pattern here

This chart's measurements are the pattern measurements based on the fabric type and serve as a reference. Ease has been added to the width measurements (in addition to the exact body measurements) for a more comfortable fit. Viva is designed to have a **loose cut**. Depending on the preferred cut, you could decide to go a size smaller or larger than the recommended size.

size	XS	S	M	L	XL	XXL	XXXL
length long dress	122.5	123.75	124.75	125.75	128.5	130	131.75
length short dress*	90	91	92.25	93.25	95.75	97.5	99
sleeve length**	41.5	42.75	44.5	46.25	48	50.25	52.5
bust	87.75	96.5	105.25	114.25	124.25	137.25	150.25
hips	110.25	119	128	136.75	147	160	173

* To make the short dress, cut pattern pieces 1 and 3 until you have this total length (incl. the yoke and the flounce).

** Including shoulder length.

Compare the stated lengths to the measured or desired lengths. **Lengthen** or **shorten** the dress and/or sleeves by cutting the pattern pieces at the indicated double lines. Then either increase the distance between the cut pieces by the desired amount (to lengthen) or overlap the pieces (to shorten). Make sure that the CF and CB lines and the side seams are always straight.



IMPORTANT

Adjust the amount of fabric to be used based on these alterations.

notions



- Thread
- Iron-on interfacing: max. 60 cm
- Fabric: see table

fabric use long dress		XS	S	M	L	XL	XXL	XXXL
fabric width 110 cm	cm	355	370	380	390	415	430	455
fabric width 140 cm	cm	275	275	280	345	360	420	440

The corresponding fabric layout can be found on page 6 of these sewing instructions.

fabric use short dress		XS	S	M	L	XL	XXL	XXXL
fabric width 110 cm	cm	295	305	320	330	350	370	395
fabric width 140 cm	cm	235	235	240	315	330	360	380

fabric advice



Oh, the possibilities! Poplin, chambray, lycell, muslin, crepe (viscose, polyester, etc.), satin, broderie Anglaise, lace...and the list just goes on! For statement sleeves be sure to choose a more structured fabric. We can't wait to see what you pick.

Proud to be #Sewista

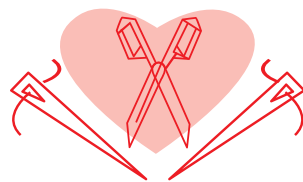



pattern pieces & seam allowances (in cm)

To sew the garment as described in the instructions, draw the illustrated seam allowances around the paper pattern pieces before cutting them out. If you are using a PDF pattern, the pattern can be printed with or without seam allowance. To find out more, watch the [video](#).

- 1. front: 1x on fabric fold
- 2. yoke front: 2x on fabric fold
- 3. back: 1x on fabric fold
- 4. yoke back: 2x on fabric fold
- 5. sleeve: 2x
- 6. flounce front: 1x on fabric fold
- 7. flounce back: 1x on fabric fold
- 8. pocket: 4x

IMPORTANT
Pattern pieces 6 and 7 are the same.

IMPORTANT
The pieces highlighted in light yellow have iron-on interfacing attached to the wrong side.

?	material type
	fabric
	iron-on interfacing

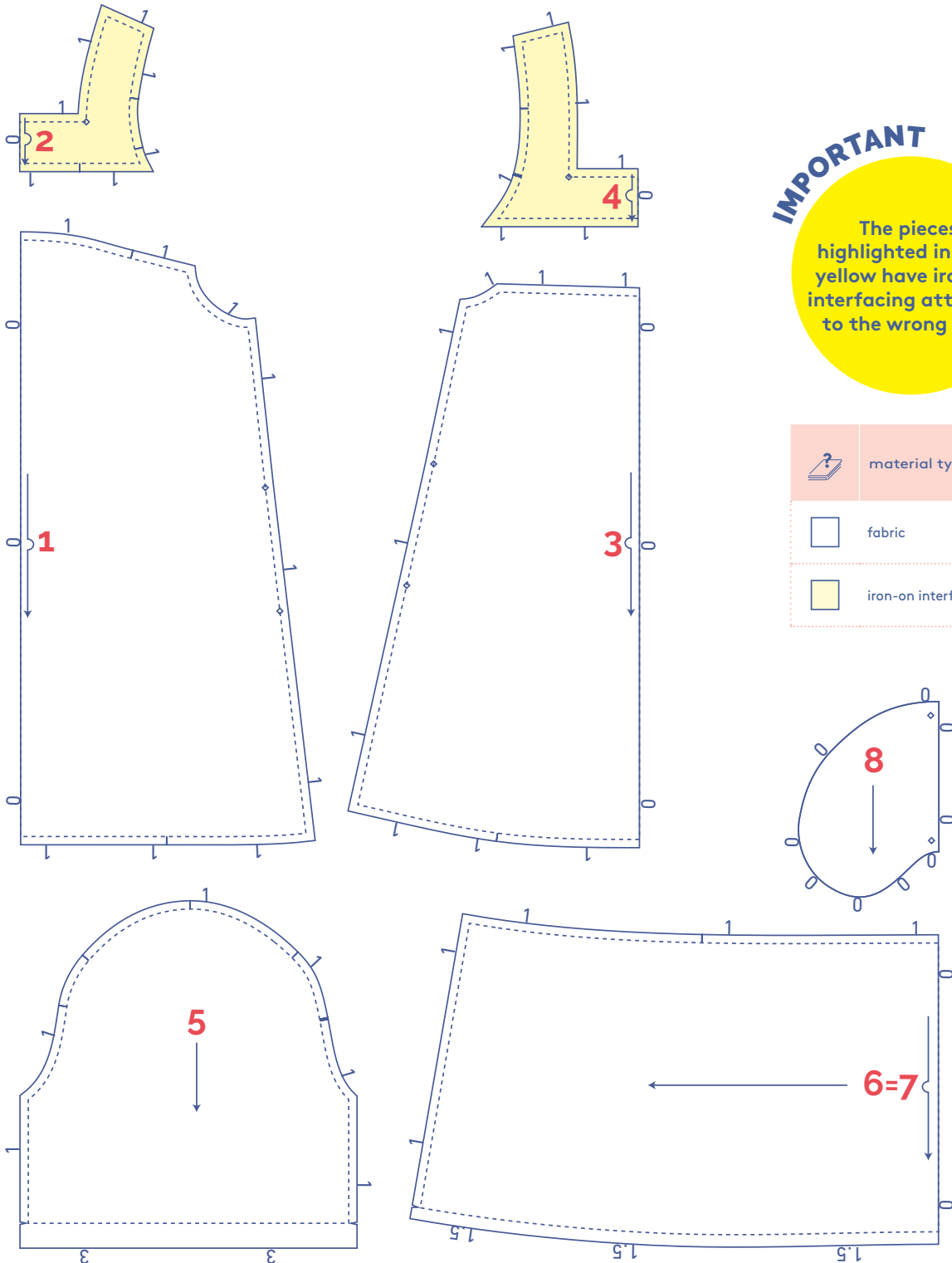

fabric layout – solid fabrics
fabric width 110 cm

XS - XL

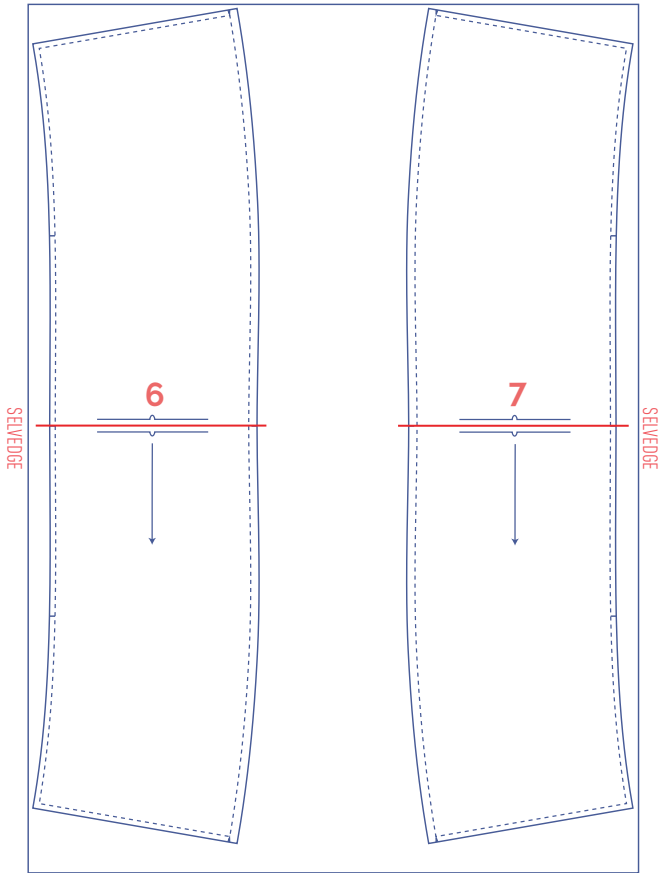
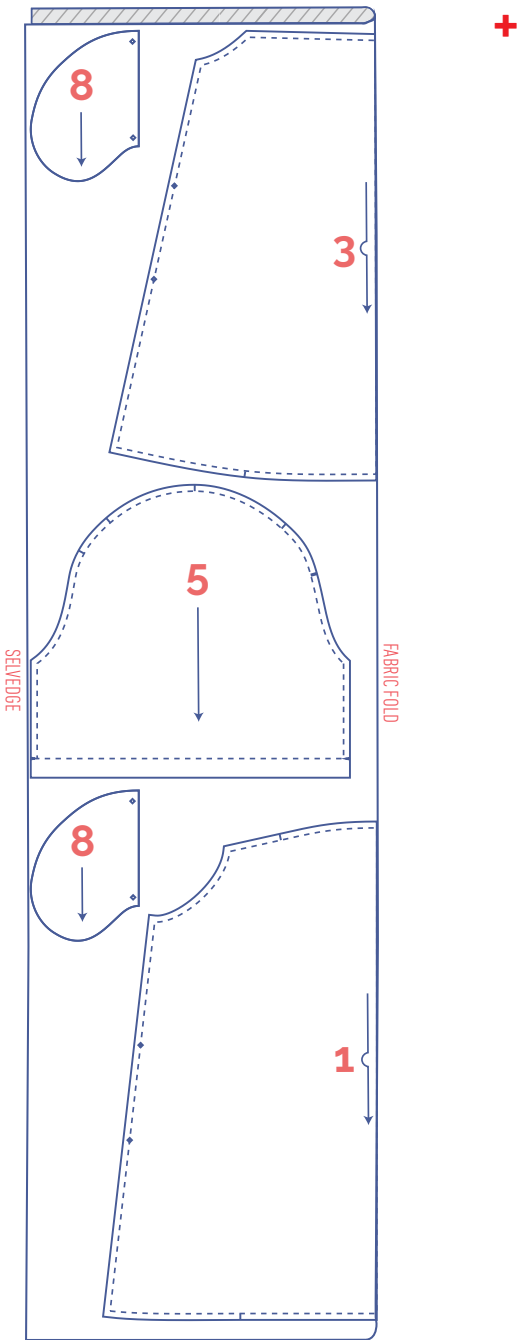

IMPORTANT

Pattern pieces 6 and 7 have been rotated at a 90° angle to fit the fabric width. If you are working with a patterned or napped fabric and you want everything in the same direction you may need some extra fabric.

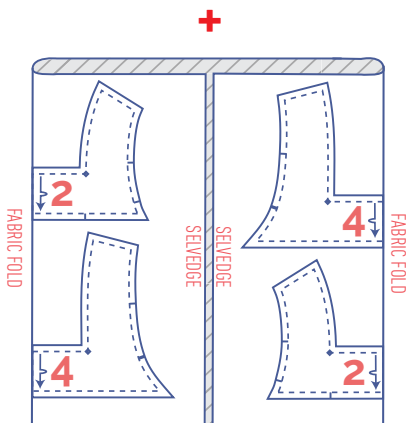

XXL - XXXL

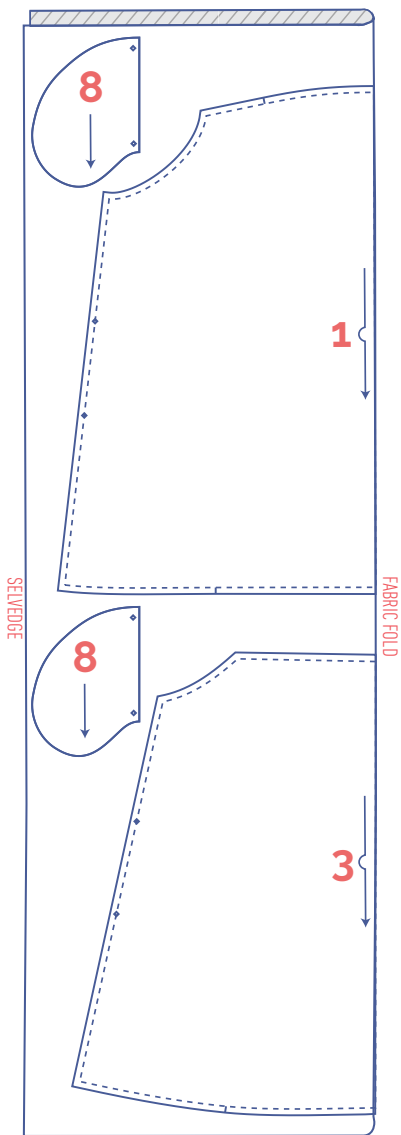

+

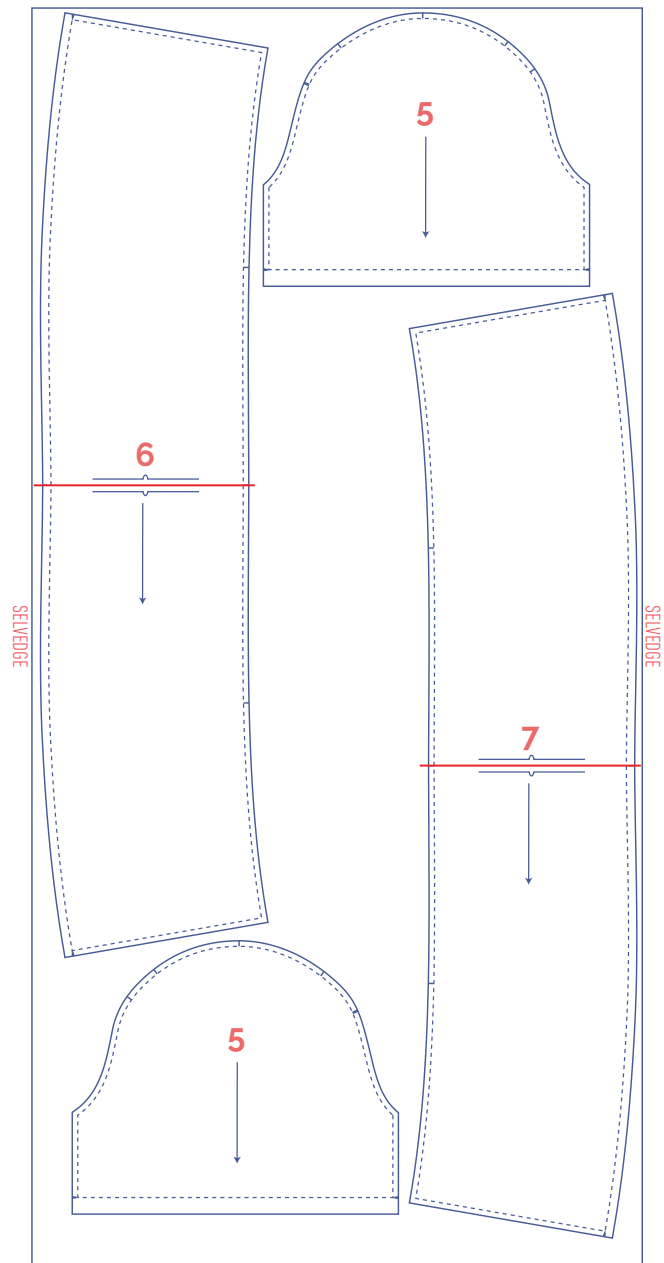

+

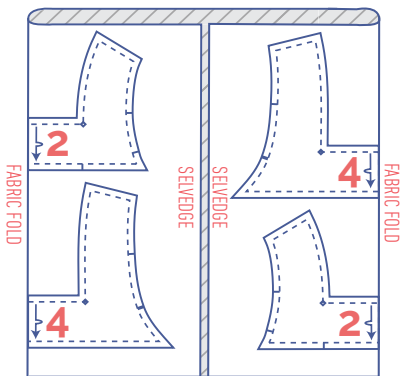

IMPORTANT

Because the fabric is opened out and single layer, you will also need to cut mirror images of pattern piece 5 so you have a left and right sleeve.

Pattern pieces 6 and 7 have been rotated at a 90° angle to fit the fabric width. This may cause problems if you are working with patterned or napped fabric.

marking pattern pieces

	Notch the pattern paper and fabric at the following points
	single notch
	double notch
V	V-notch/fabric fold

	Mark the following points with marking thread
	centre point

fabric layout – solid fabrics
fabric width 140 cm

XS - M

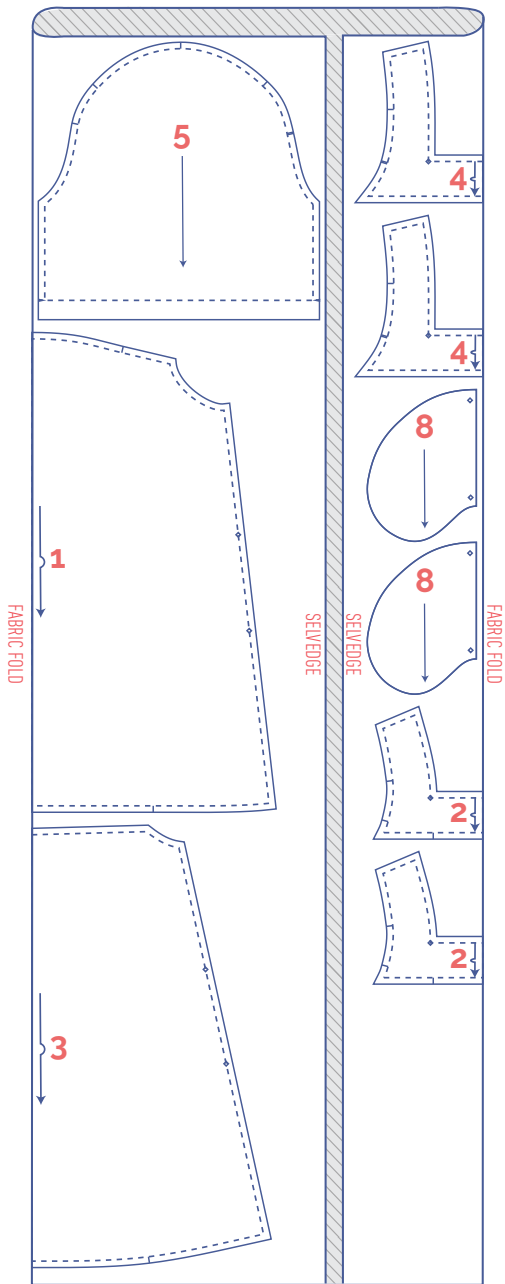

+

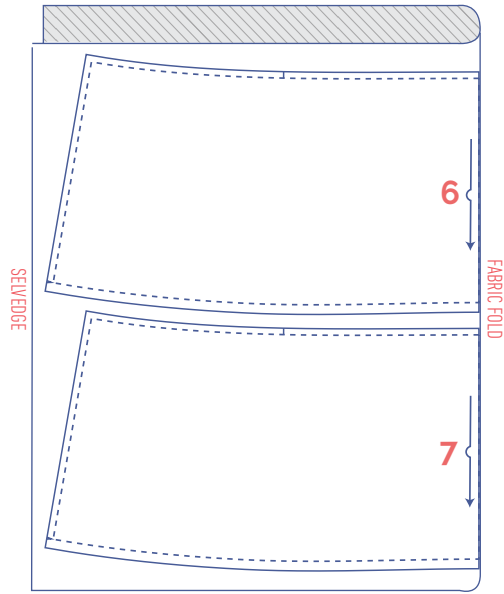

L - XL

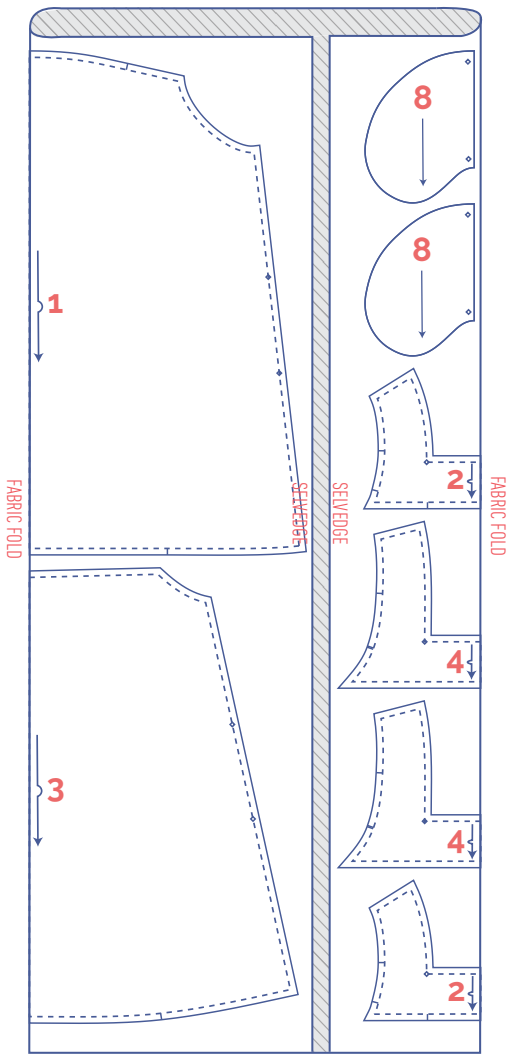

+

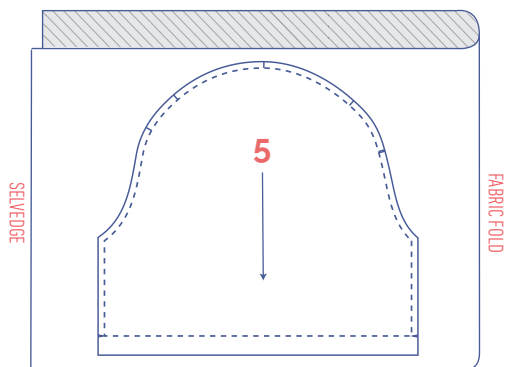

+

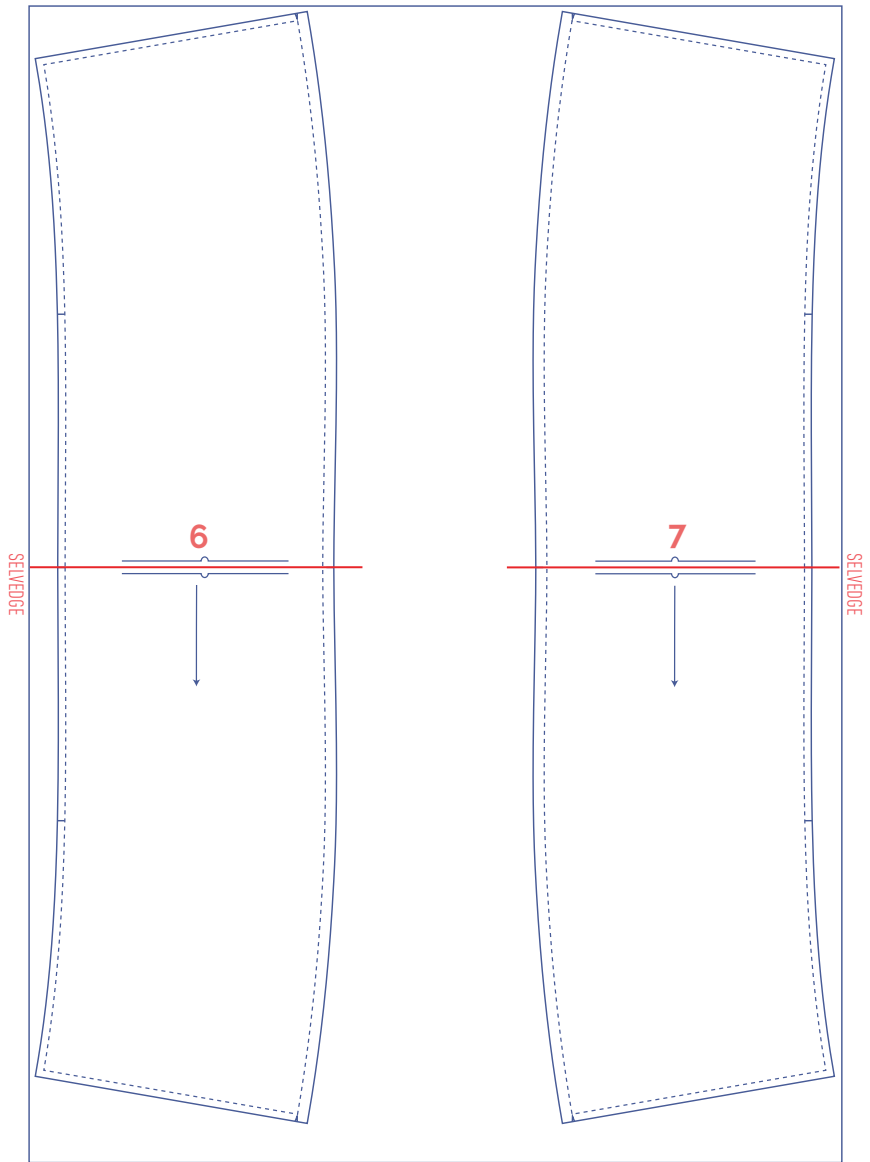

IMPORTANT

Pattern pieces 6 and 7 have been rotated at a 90° angle to fit the fabric width. This may cause problems if you are working with patterned or napped fabric.

XXL - XXXL

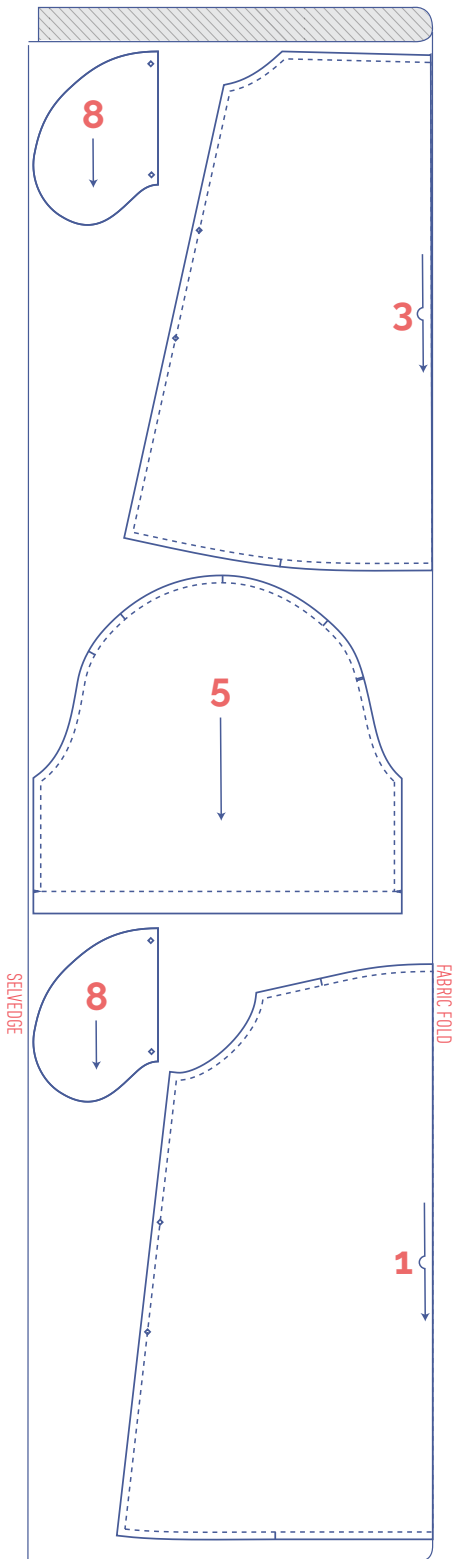

+

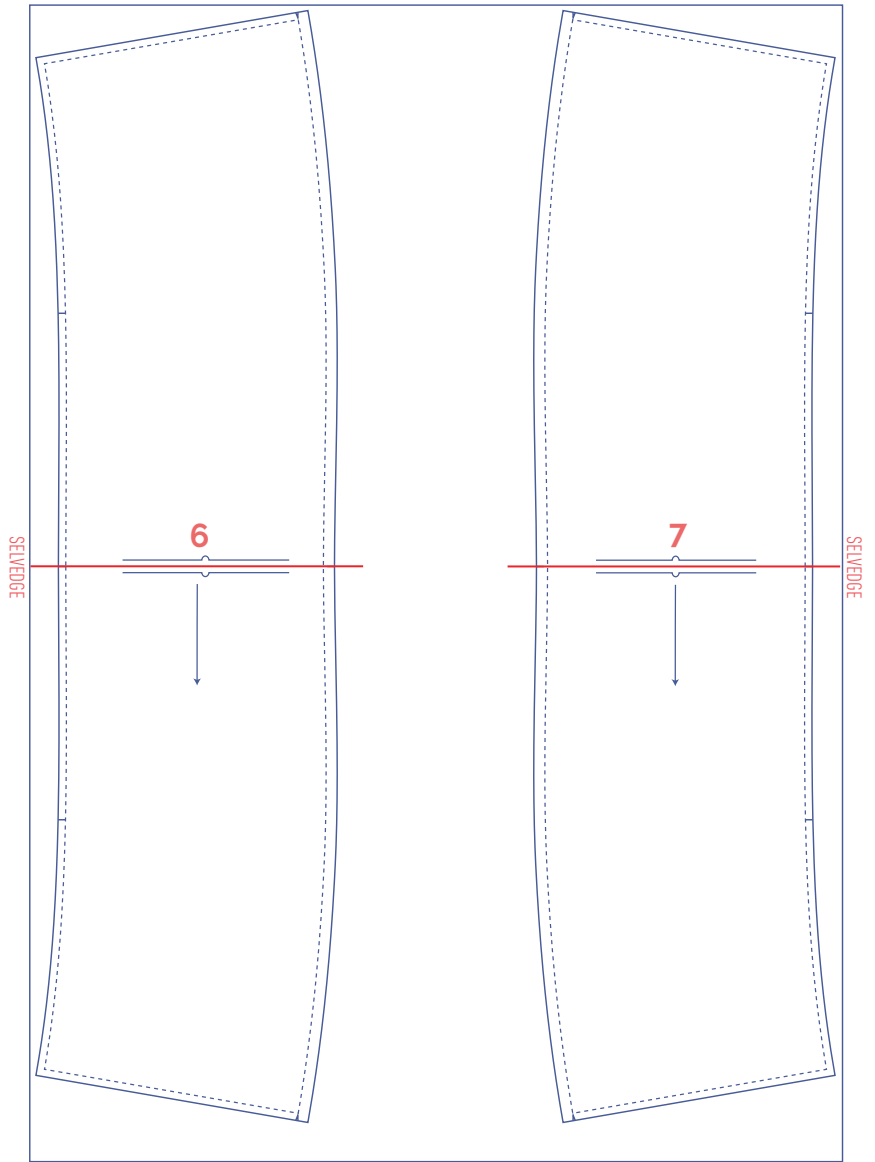



IMPORTANT

Pattern pieces 6 and 7 have been rotated at a 90° angle to fit the fabric width. If you are working with a patterned or napped fabric and you want everything in the same direction you may need some extra fabric.

marking pattern pieces

	Notch the pattern paper and fabric at the following points
	single notch
	double notch
V	V-notch/fabric fold

	Mark the following points with marking thread
	centre point

sewing instructions



The method used to finish the seams depends on the fabric used.
The pieces are always sewn together with the right sides of the fabric facing, unless stated otherwise.

F front

B back

CF centre front

CB centre back

 right side

 wrong side

 iron-on interfacing

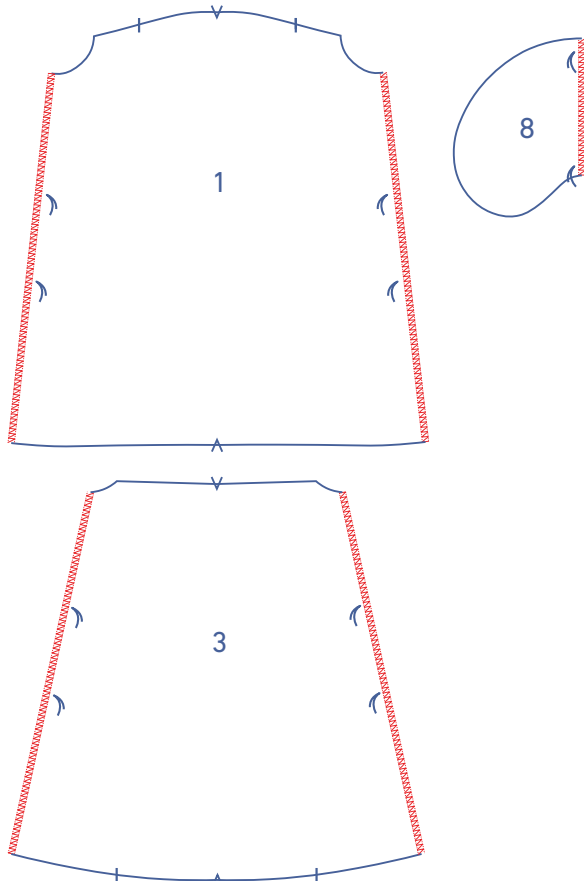
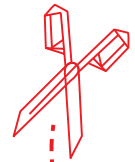

1

Finish the raw edges of the front (1), back (3), and the straight ends of the pocket pieces (8) with overlock stitching where indicated.

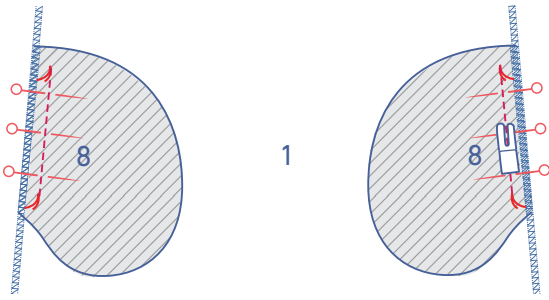

Pin the straight ends of two of the four pocket pieces to the front, matching the marking threads. Sew into place between the marking threads.

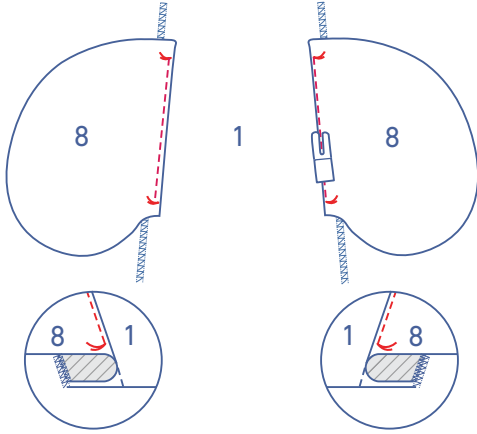

Fold the pocket and seam allowance over and sew the pocket to the seam allowance underneath.

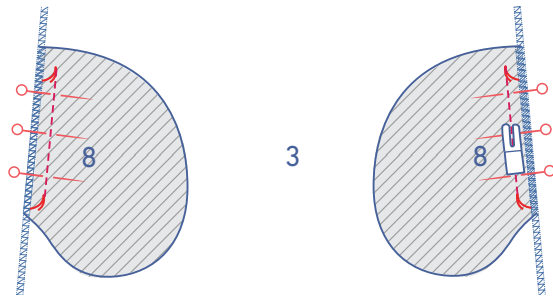

Pin the straight ends of the two remaining pocket pieces to the back, matching the marking threads. Sew into place between the marking threads.

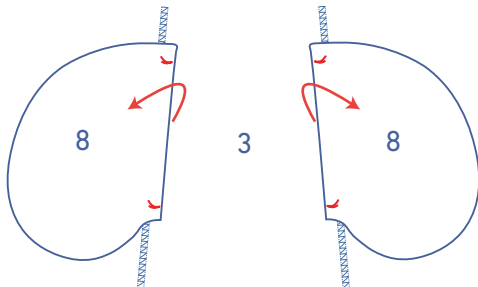

Fold the pocket pieces over.

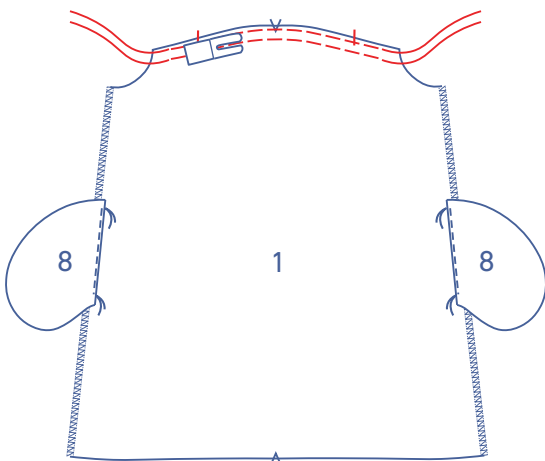

2

Sew the top of the front with two parallel lines of stitching until just past the indicated notches. Use a long stitch at a low thread tension. Leave a length of thread at the start and end of your stitching.

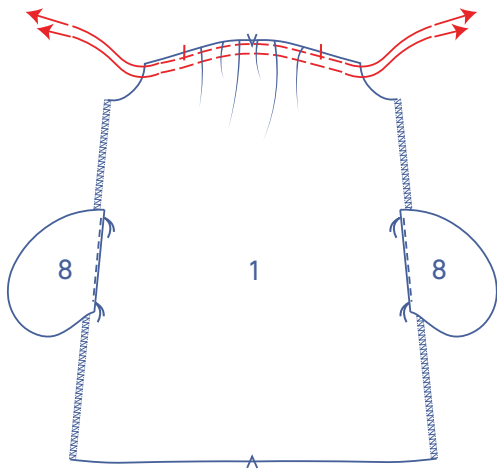

Gently tug the ends of the threads to gather the fabric.

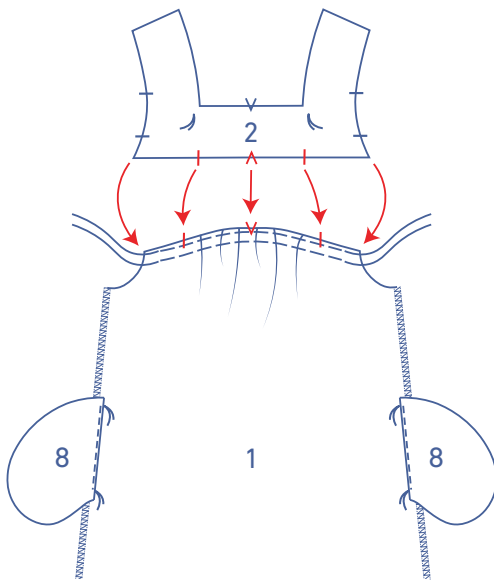

Distribute the gathers until the notches in the front match the notches in the yoke front (2).

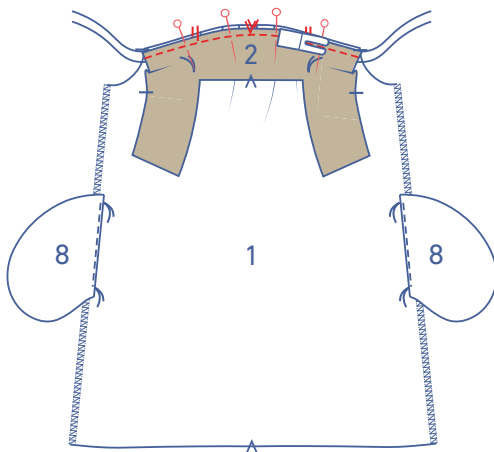

Pin and sew the front to the yoke front, matching the markings.

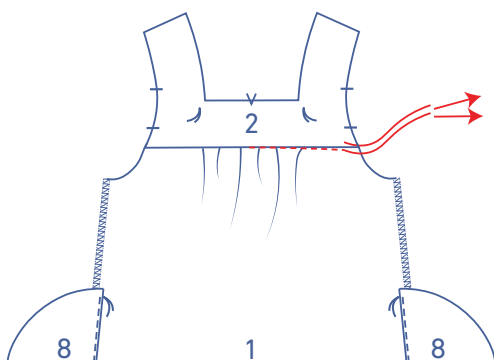

Remove the gathering threads.

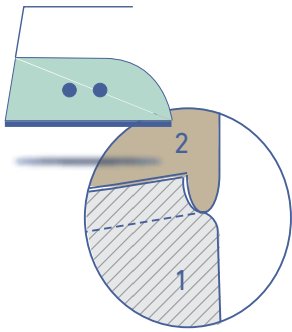

Press the seam allowance towards the yoke.

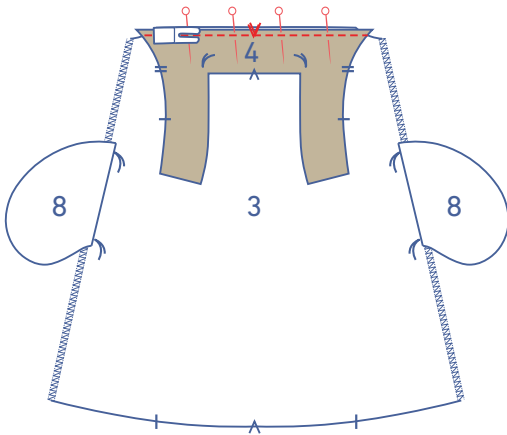

Pin and sew the back to the yoke back (4), matching the markings.

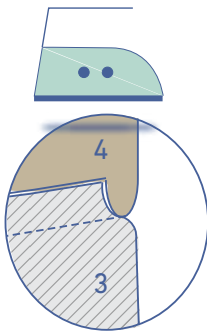

Press the seam allowance towards the yoke.

3

Pin the shoulder seams together and sew. Press the seam allowance open.

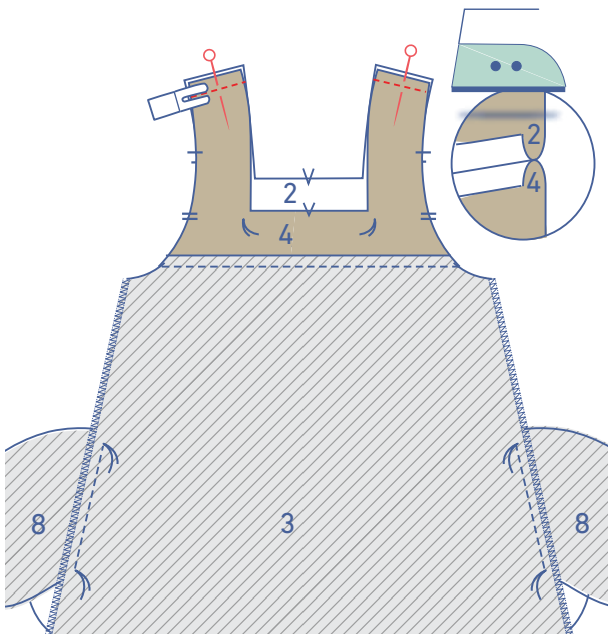

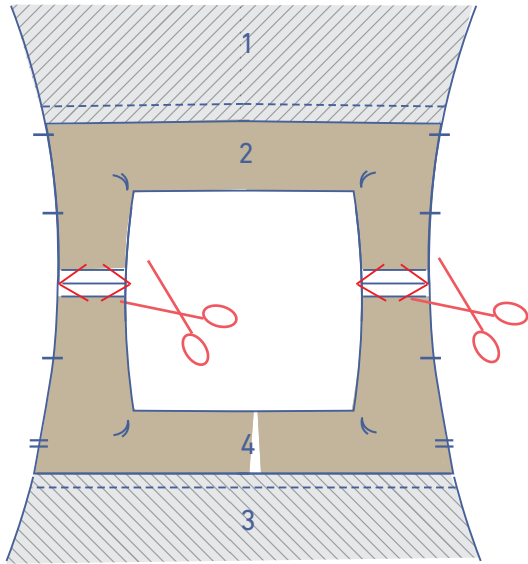

Diagonally clip the seam allowance at the tips to prevent bunching.

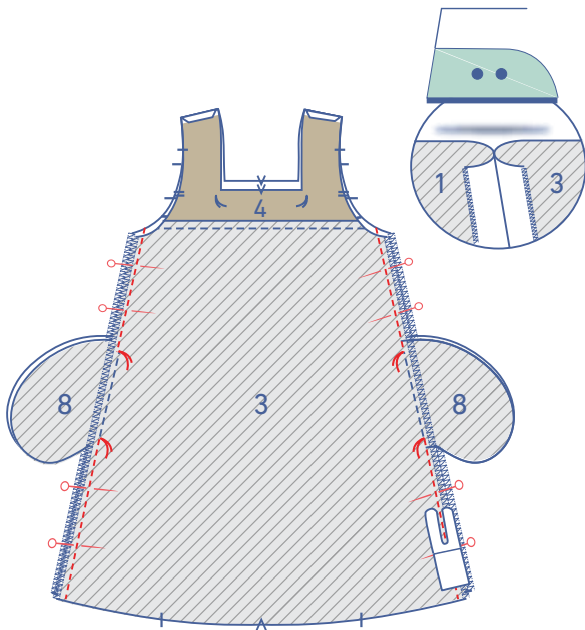

Pin and sew the side seams. Sew up to the marking threads that mark the top of the pocket opening. Then, continue sewing from the next set of marking threads to the hem. Press the seam allowance open.

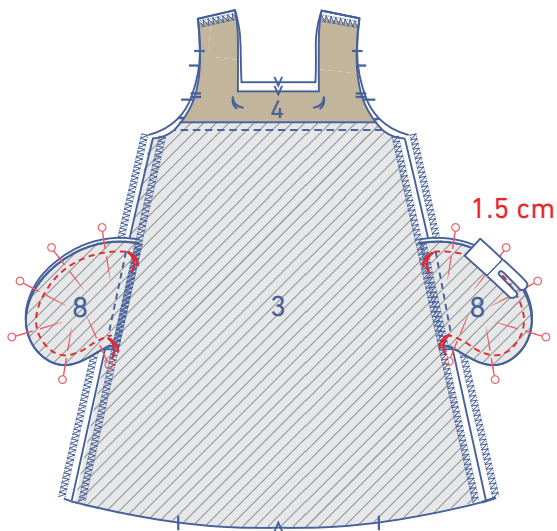

Pin and sew the contours of the pocket pieces together at 1.5 cm.

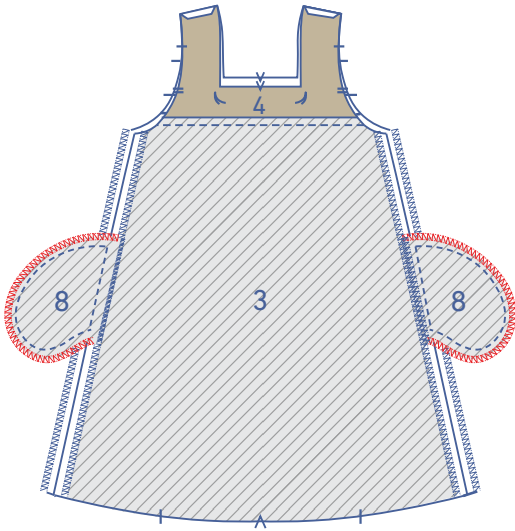

Finish the raw edges with overlock stitching.

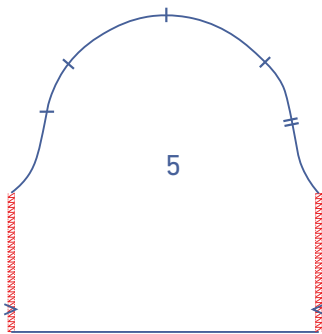

4

Finish the sleeve sides (5) with overlock stitching.

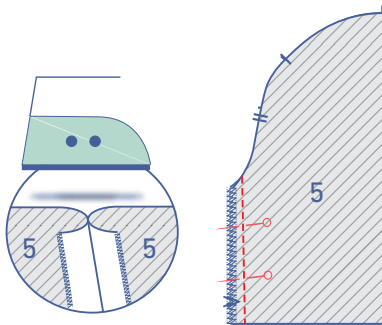

Pin and sew the sides of the sleeve. Press the seam allowances open.

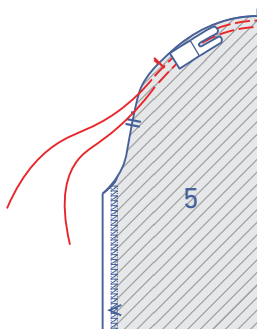

Using a long stitch length at a low thread tension, sew the top of the sleeve with two lines of parallel stitching until just past the indicated notches. Leave a length of thread at the start and end of your stitching.

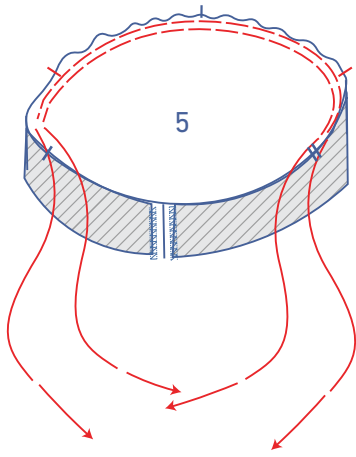

Gently tug the ends of the threads to gather the fabric.

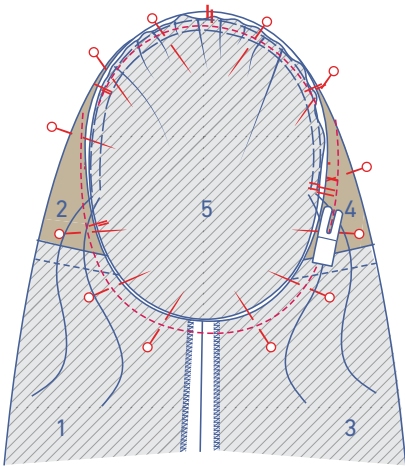

Pin and sew the sleeve to the dress, matching the notches. The single notch closest to the underarm marks the front, while the double notch marks the back. The single notch at the top aligns with the shoulder seam. Distribute the gathers until the single notches in the sleeve match those of the yoke.

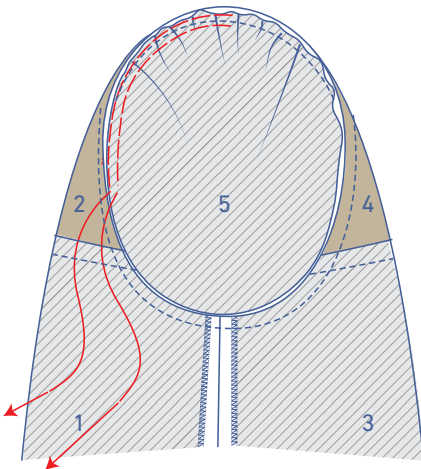

Remove the gathering threads.

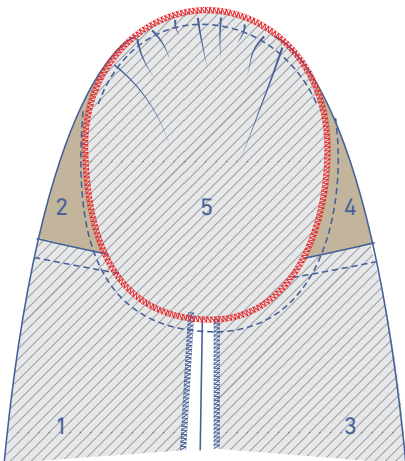

Finish the raw edges with overlock stitching.

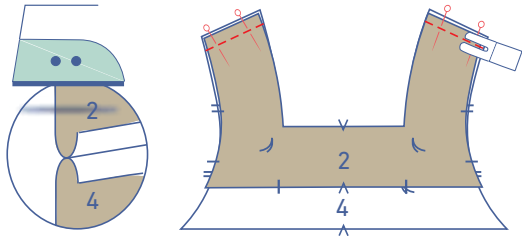

5

Pin the shoulder seams of the remaining yoke front and yoke back pieces together and sew (this is the inner yoke). Press the seam allowance open.

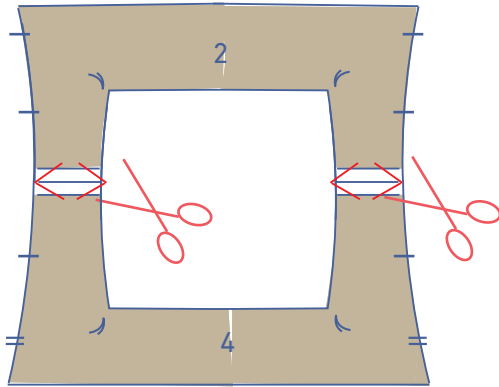

Diagonally clip the seam allowance at the tips to prevent bunching.

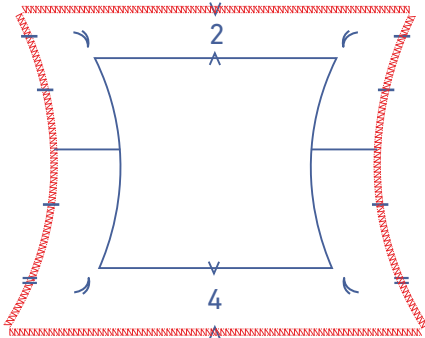

Finish the ends with overlock stitching where indicated.

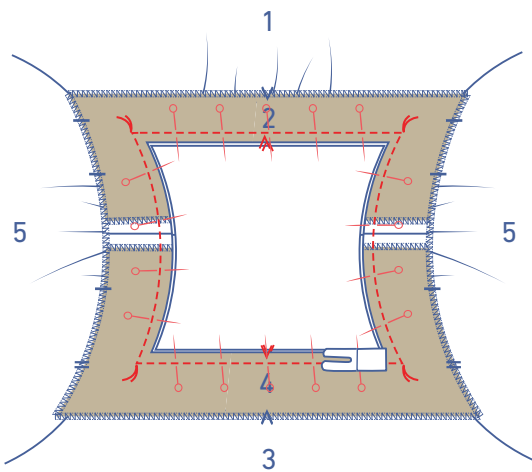

Place the inner yoke you just constructed on top of the neckline of the dress, right sides together.

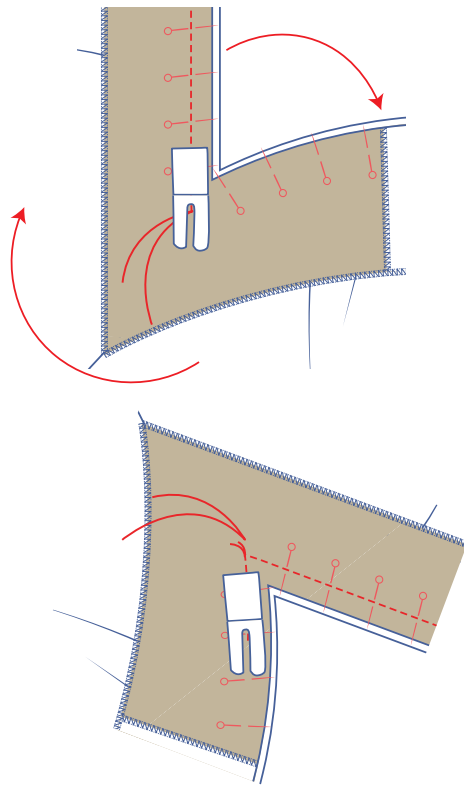

Sew the neckline. At each corner (marked with marking threads), leave the needle in your fabric, raise the presser foot, pivot the garment, lower the presser foot back down, and continue sewing.

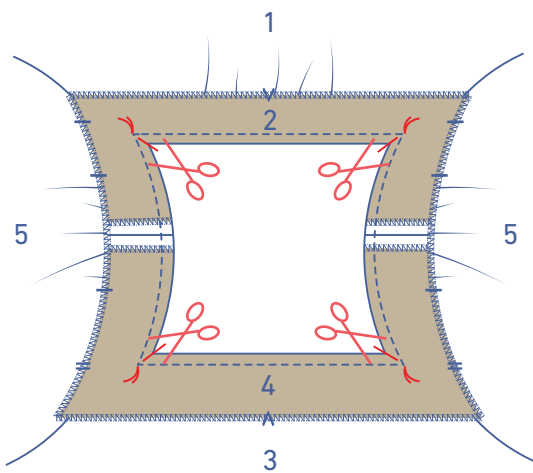

Clip diagonally into the seam allowance at the corners. To create clean right angles, clip to just before the marking thread.

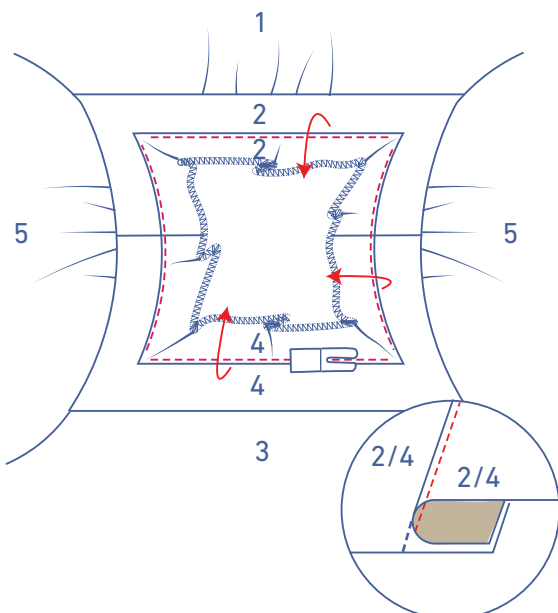

Fold the inner yoke over and sew to the seam allowance underneath, sewing right next to the seam. Sew as closely possible to the corners. The purpose is to create a lovely, straight neckline that does not flip or peek out when you are wearing the dress. Hold the facing taut to sew the straight ends with the fabric as flat as possible.

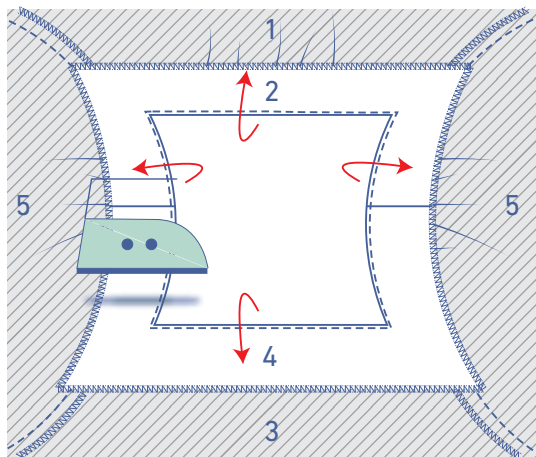

Turn the inner yoke over to the wrong side, and neatly press flat.

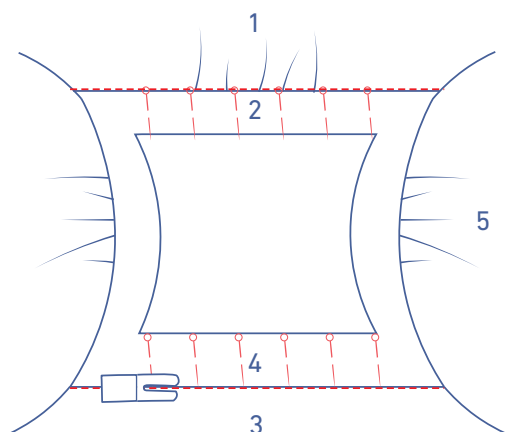

Pin both yoke pieces together along the right side of the dress. Then, stitch in the ditch where indicated to secure the inner yoke.

6

Finish the raw edges of the flounce front (6) and flounce back (7) pieces with overlock stitching where indicated.

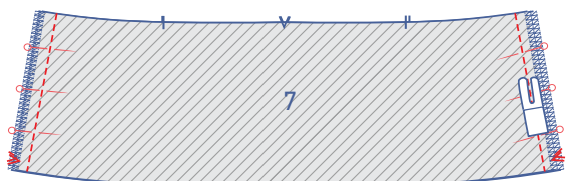
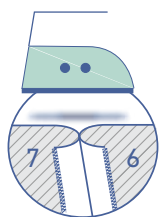
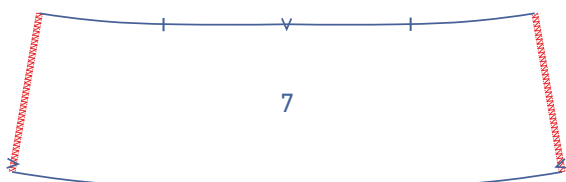
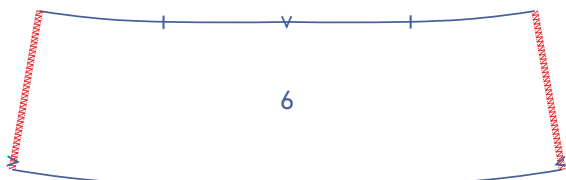

Pin and sew the side seams. Press the seam allowance open.

Use a long stitch at a low thread tension to sew the top of the flounce with two parallel lines of stitching. Leave a length of thread at the start and end of the stitching.

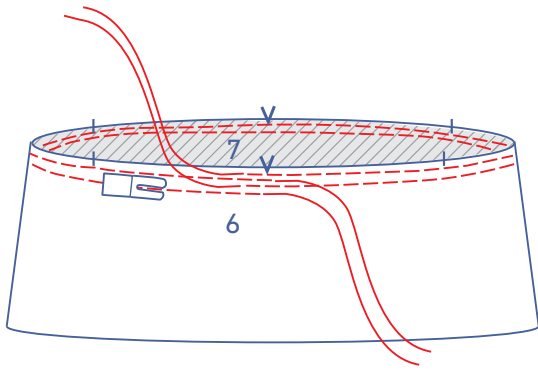

Gently tug the ends of the threads to gather the fabric.

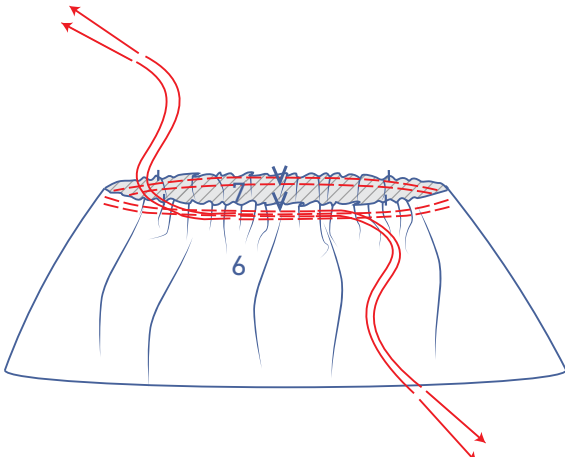

Distribute the gathers until the flounce notches match those in the bottom of the front and back.

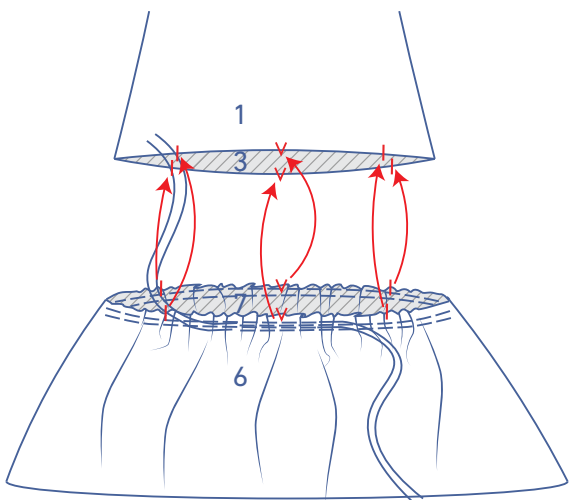

Slide the flounce over the skirt, right sides together. Pin and sew the flounce to the dress, matching the notches.

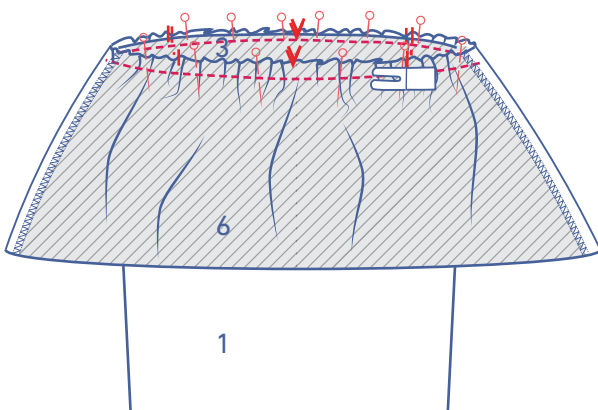

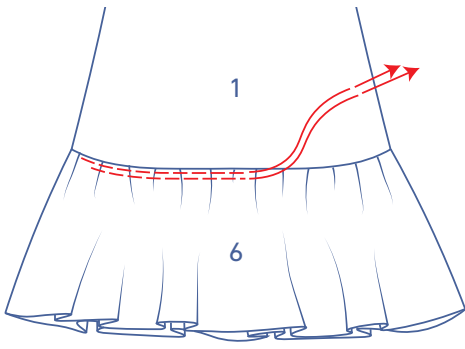

Remove the gathering threads.

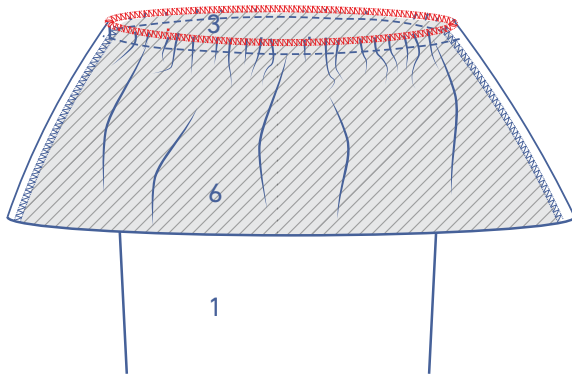

Finish the raw edges with overlock stitching.

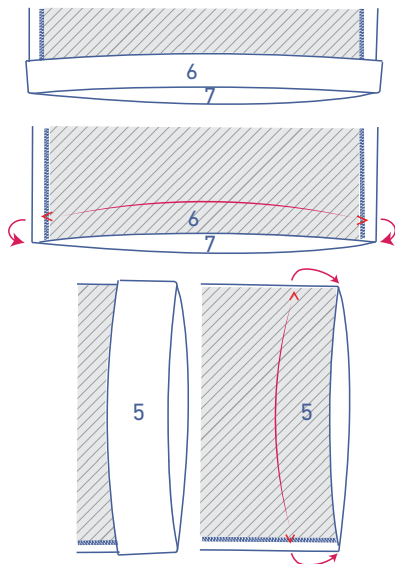

7

Press the hem allowance of the dress and sleeves towards the wrong side and open back out.

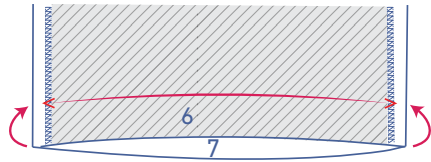

Fold the raw edge up to meet the pressed fold line and fold over again.

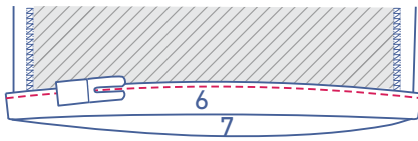
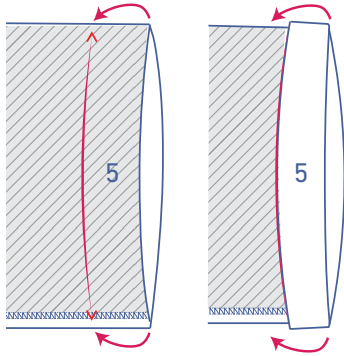
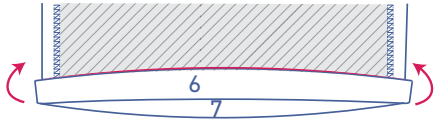

Edgestitch into place.

