

Paola by Fibre ⚡ood



Paola by Fibre ood



XS - XXXL

Is it a hoodie or not? That's up to you! Paola looks great with or without a hood and is just the ticket with or without a kangaroo pocket. Either way, you're the boss. You could also make the sleeves three-quarter length or longer. Or maybe you're already tempted to sew a pair of Paolas in one go! One thing's for sure, though – the stretch trim fabric makes for a supremely comfortable fit and keeps your head snug and warm.

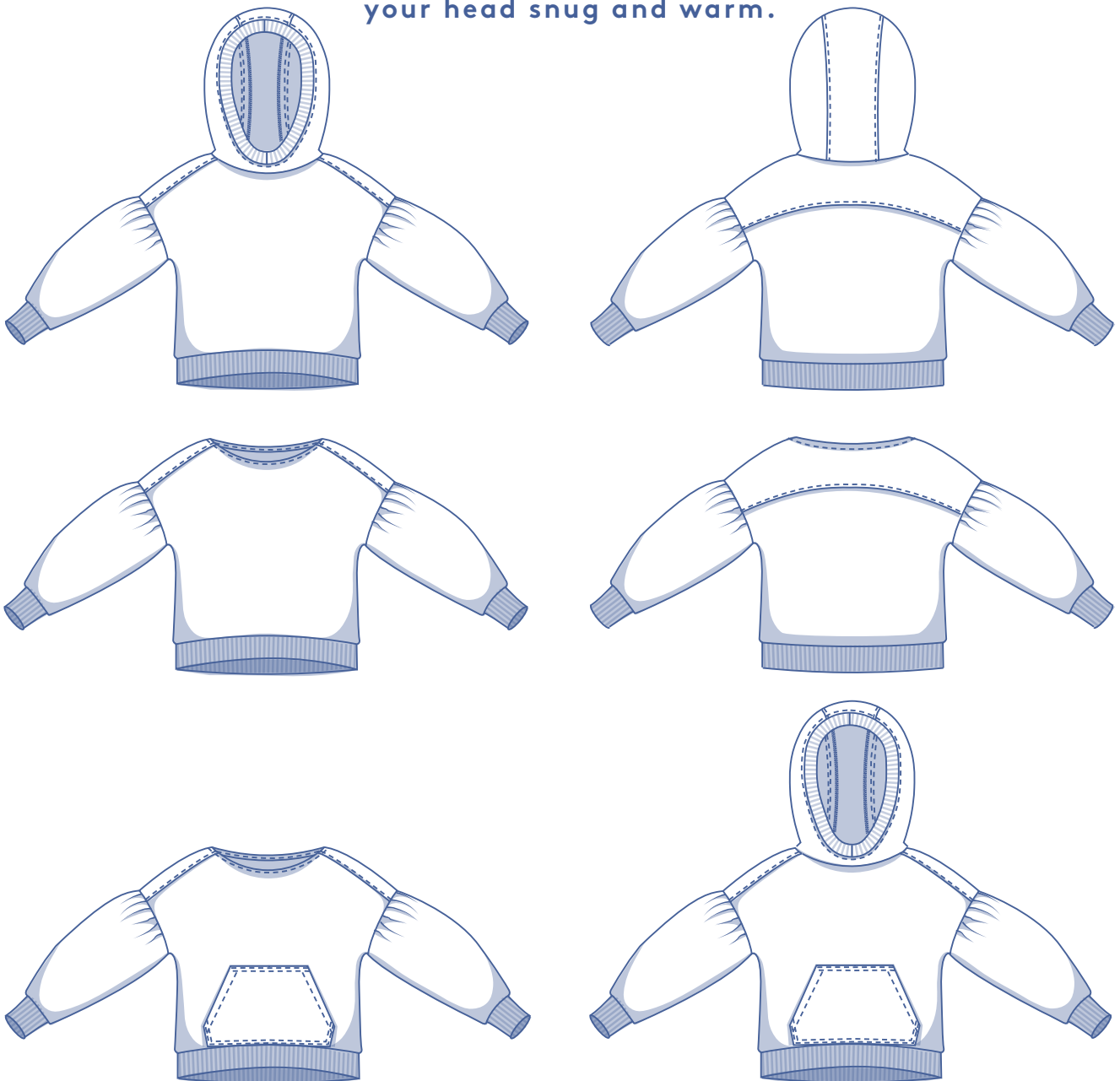

size chart (in cm)

| size | XS | | S | | M | | L | | XL | | XXL | | XXXL | | |
|-------------|-----|-----|-----|-----|-----|-----|-----|-----|-----|-----|-----|-----|------|-----|-----|
| | 4 | 6 | 8 | 10 | 12 | 14 | 16 | 18 | 20 | 22 | 24 | 26 | 28 | 30 | 32 |
| body height | 160 | 164 | 166 | 167 | 168 | 169 | 170 | 171 | 172 | 172 | 172 | 172 | 172 | 172 | 172 |
| B (bust) | 76 | 80 | 84 | 88 | 92 | 96 | 100 | 104 | 110 | 116 | 122 | 128 | 134 | 140 | 146 |

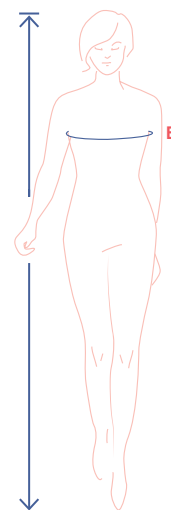

Choose your size based on your **bust measurement**. Pick the size that is the best match for your bust.

pattern measurements (in cm)

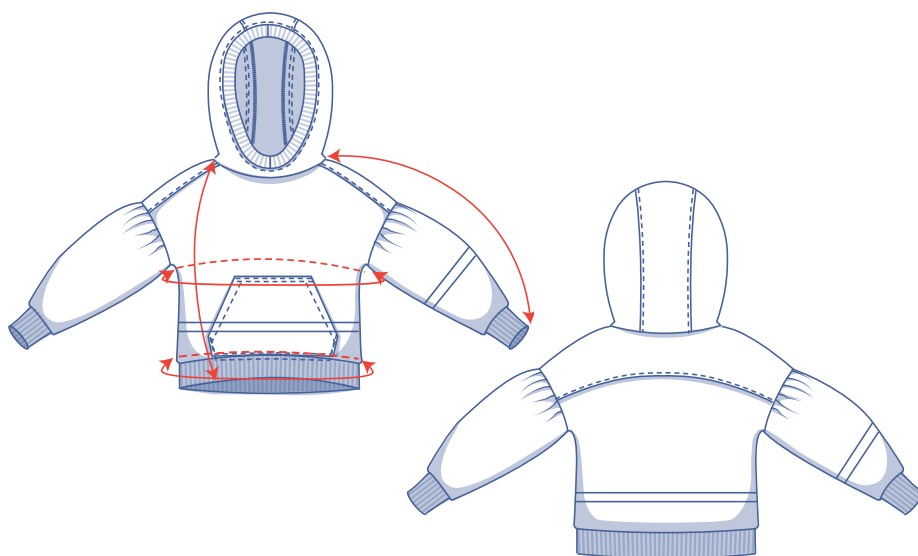

This chart's measurements are the pattern measurements based on the fabric type and serve as a reference. Ease has been added to the width measurements (in addition to the exact body measurements) for a more comfortable fit. Paola is designed to have a **loose cut**.

Not fond of loose cuts? Just go a size smaller.

| size | XS | S | M | L | XL | XXL | XXXL |
|----------------------|-------|-------|--------|--------|--------|--------|--------|
| length* | 58.25 | 60 | 61.75 | 63.75 | 66 | 68.25 | 70.5 |
| sleeve length** | 58 | 59.75 | 61.5 | 63.25 | 65.25 | 67.5 | 69.75 |
| bust | 97.5 | 105.5 | 113.5 | 121.5 | 131.5 | 143.5 | 155.5 |
| hem circumference*** | 87.75 | 95.75 | 103.75 | 111.75 | 121.75 | 133.75 | 145.75 |

* Including hem band.

** Including the shoulder length and wrist trim.

*** Measured above the hem band.

Compare the stated lengths to the measured or desired lengths. **Lengthen** or **shorten** the sweatshirt and/or sleeves by cutting the pattern pieces at the indicated double lines. Then either increase the distance between the cut pieces by the desired amount (to lengthen), or overlap the pieces (to shorten). Make sure that the CF and CB lines and the side seams are always straight.



IMPORTANT

Adjust the amount of fabric to be used based on these alterations.

notions

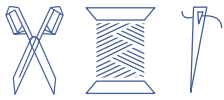

Hoodless version:

- Thread
- Bias tape (folded width 2 cm): see table
- Trim fabric (35 cm wide): see table
- Fabric: see table

Hoodie version:

- Thread
- Trim fabric (35 cm wide): see table
- Fabric: see table

| bias tape | | XS | S | M | L | XL | XXL | XXXL |
|-----------|----|----|----|----|----|----|-----|------|
| neckline | cm | 60 | 60 | 65 | 65 | 65 | 65 | 65 |

| trim fabric | | XS | S | M | L | XL | XXL | XXXL |
|------------------|----|----|----|----|----|----|-----|------|
| hoodless version | cm | 40 | 40 | 55 | 55 | 55 | 55 | 55 |
| hoodie version | cm | 75 | 75 | 75 | 75 | 75 | 75 | 75 |

The corresponding fabric layout can be found on page 6 of these sewing instructions.

| fabric use hoodless version | | XS | S | M | L | XL | XXL | XXXL |
|-----------------------------|----|-----|-----|-----|-----|-----|-----|------|
| fabric width 110 cm | cm | 170 | 180 | 195 | 230 | 240 | 250 | 255 |
| fabric width 140 cm | cm | 115 | 120 | 120 | 125 | 180 | 185 | 205 |

The corresponding fabric layout can be found on page 6 of these sewing instructions.

| fabric use hoodie version | | XS | S | M | L | XL | XXL | XXXL |
|---------------------------|----|-----|-----|-----|-----|-----|-----|------|
| fabric width 110 cm | cm | 210 | 225 | 235 | 245 | 255 | 265 | 275 |
| fabric width 140 cm | cm | 160 | 165 | 170 | 175 | 180 | 185 | 205 |

The corresponding fabric layout can be found on page 6 of these sewing instructions.

fabric advice Knitted fabrics and Paola are a match made in heaven, e.g. French Terry, sweatshirt fabric, thin or even chunky-knit fabric, Ponte Roma. Make the wrist trim, hood trim, and hem band in (rib) trim fabric. Fancy pushing the envelope? Make Paola in Teddy or scuba and steal the show!



Proud to be #Sewista

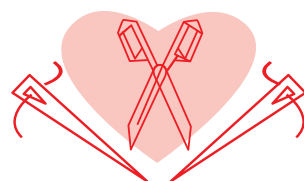

pattern pieces & seam allowances (in cm)

To sew the garment as described in the instructions, draw the illustrated seam allowances around the paper pattern pieces before cutting them out. If you are using a PDF pattern, the pattern can be printed with or without seam allowance. To find out more, watch the [video](#).

1. front: 1x on fabric fold
2. back: 1x on fabric fold
3. yoke: 1x on fabric fold
4. sleeve: 2x
5. wrist trim: 2x
6. hem band front: 1x
7. hem band back: 1x
8. hood: 1x on fabric fold
9. middle section hood: 1x on fabric fold
10. hood trim: 2x
11. pocket: 1x on fabric fold (optional)

IMPORTANT

Pattern pieces 6 and 7 are the same.

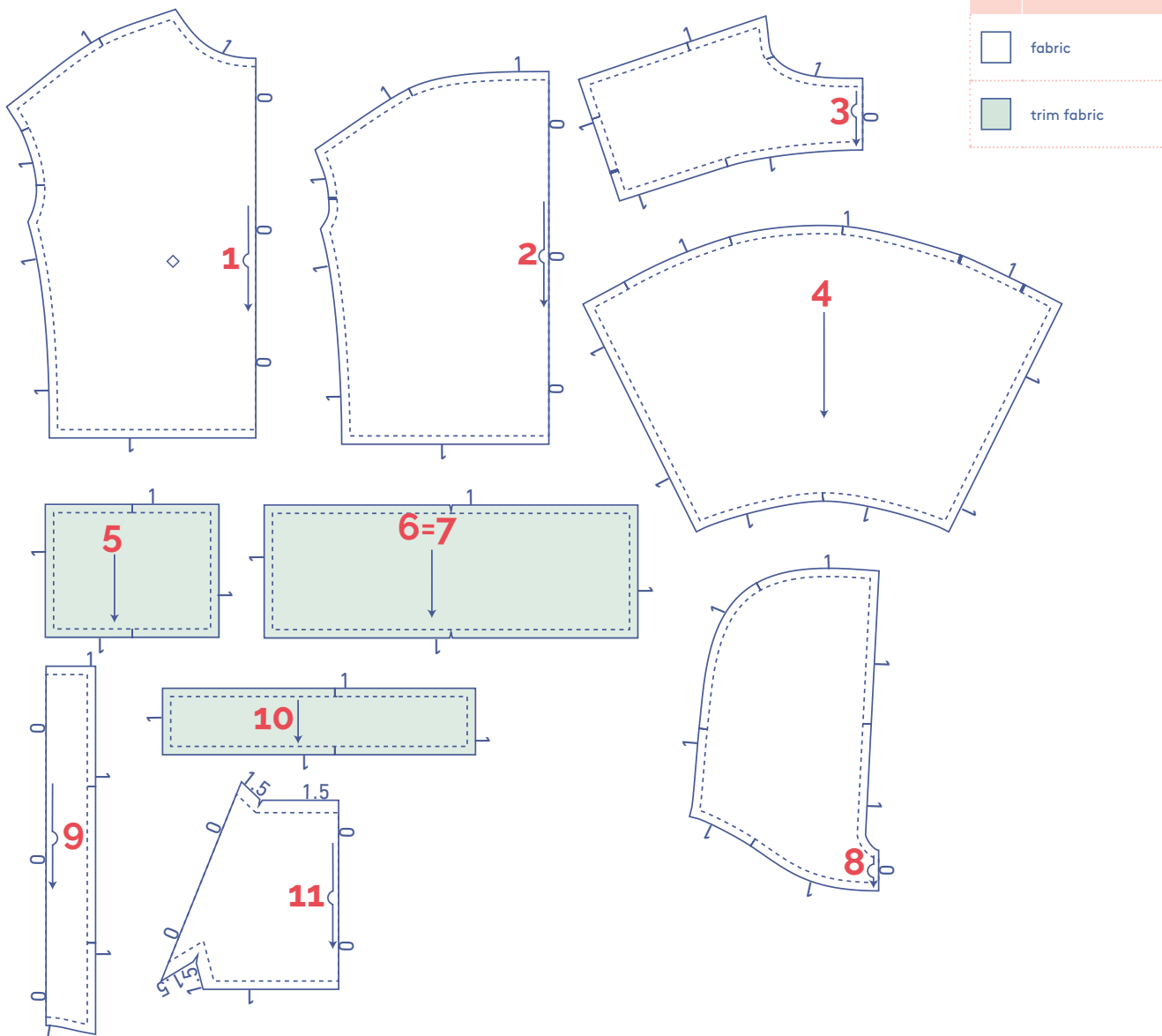

NOTE

Paola can be made in a number of different ways. There's a version with or without a hood, and you decide whether or not to include the kangaroo pocket. All pattern pieces (pattern piece 11, i.e. the pocket, is optional) are used in the [hoodie](#) version.

The [hoodless](#) version requires pattern pieces 1 through 7 (pattern piece 11, i.e. the pocket, is optional). Finish the neckline with bias tape.

fabric layout – solid fabrics
fabric width 110 cm

hoodless version

XS - M

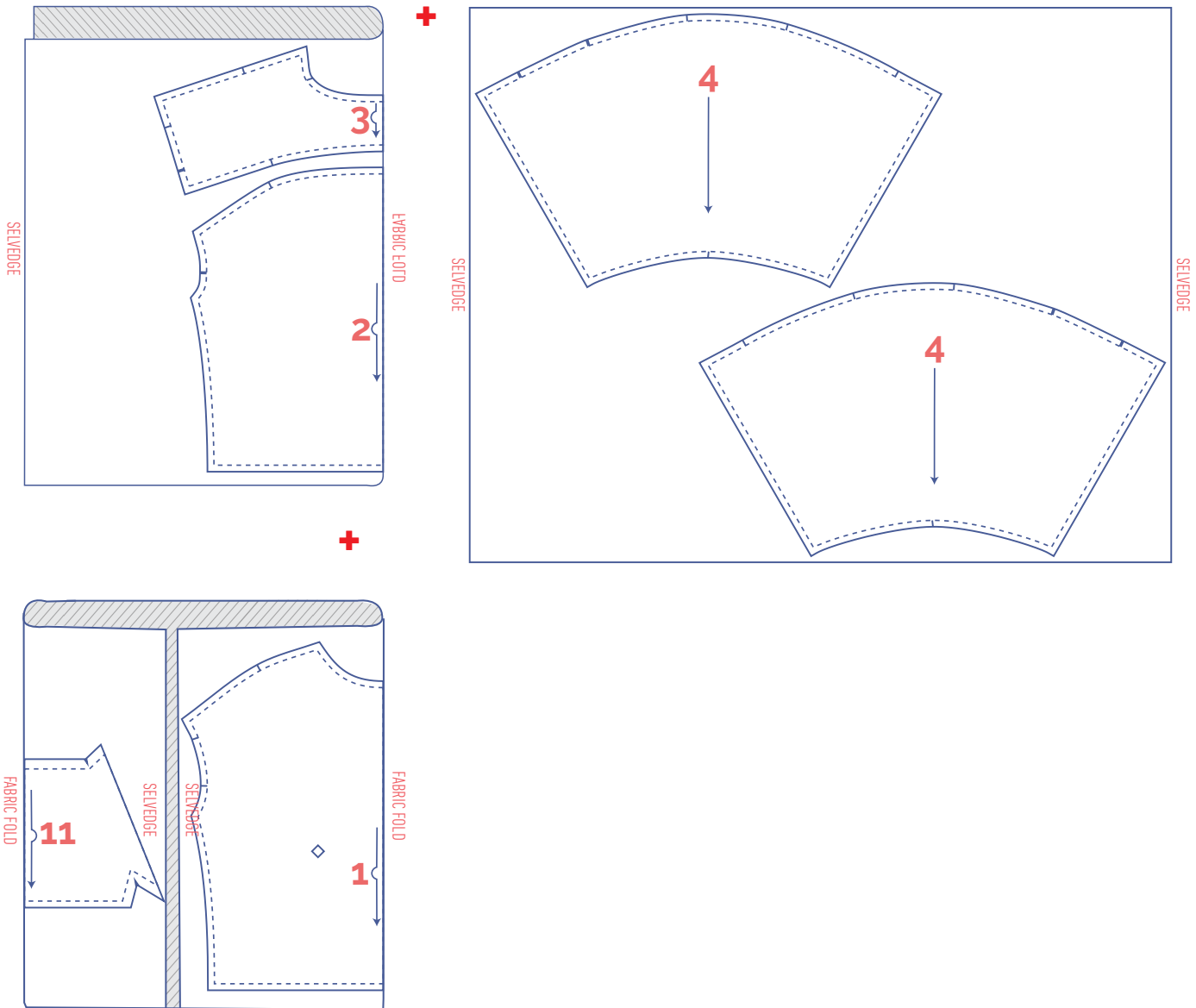

L - XXXL

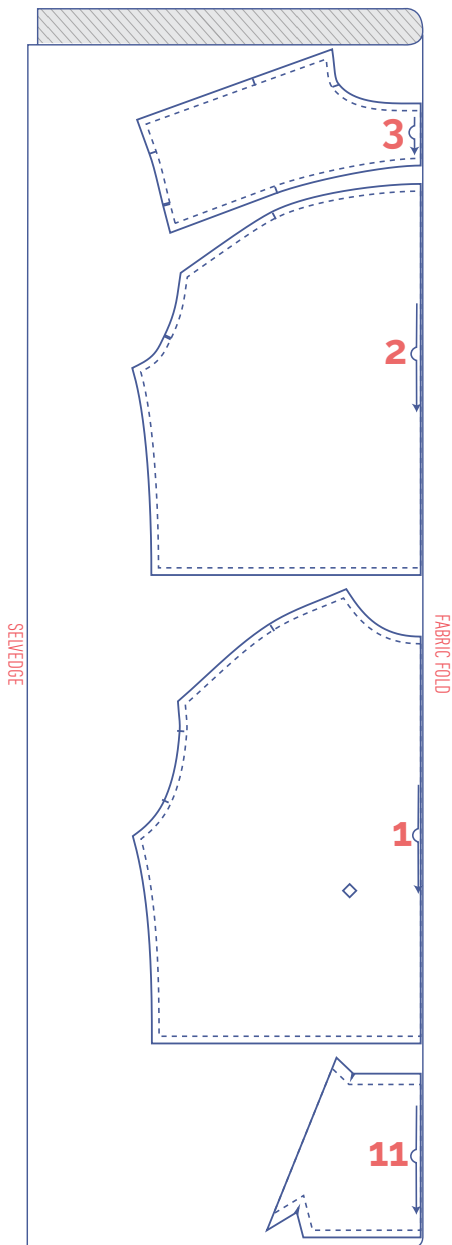

+

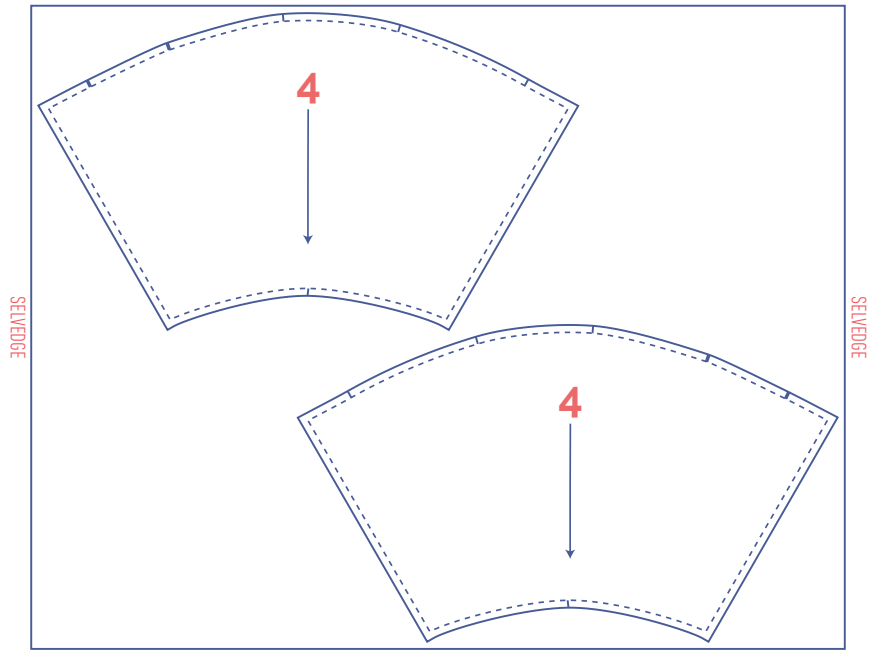

trim fabric layout

XS - S

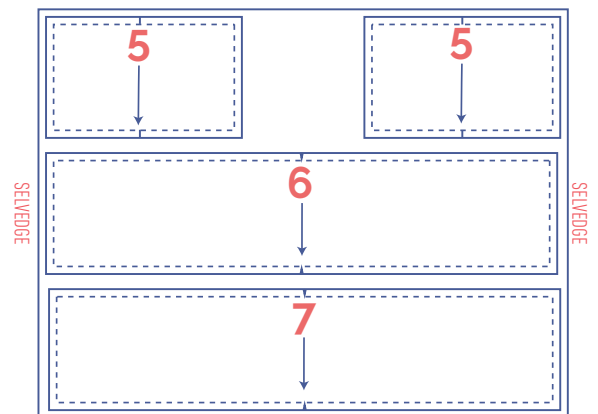

M - XXXL

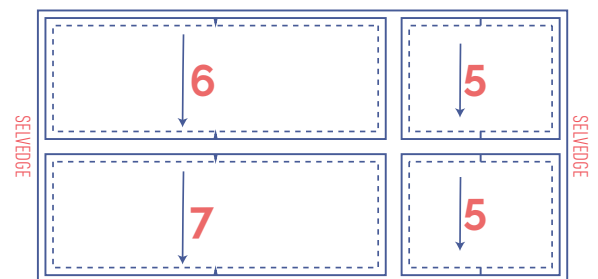

marking pattern pieces

 notch the pattern paper and fabric at the following points

| single notch

|| double notch

V V notch

 mark the following points using marking thread:

 centre point

fabric layout – solid fabrics
fabric width 140 cm

hoodless version

XS - L

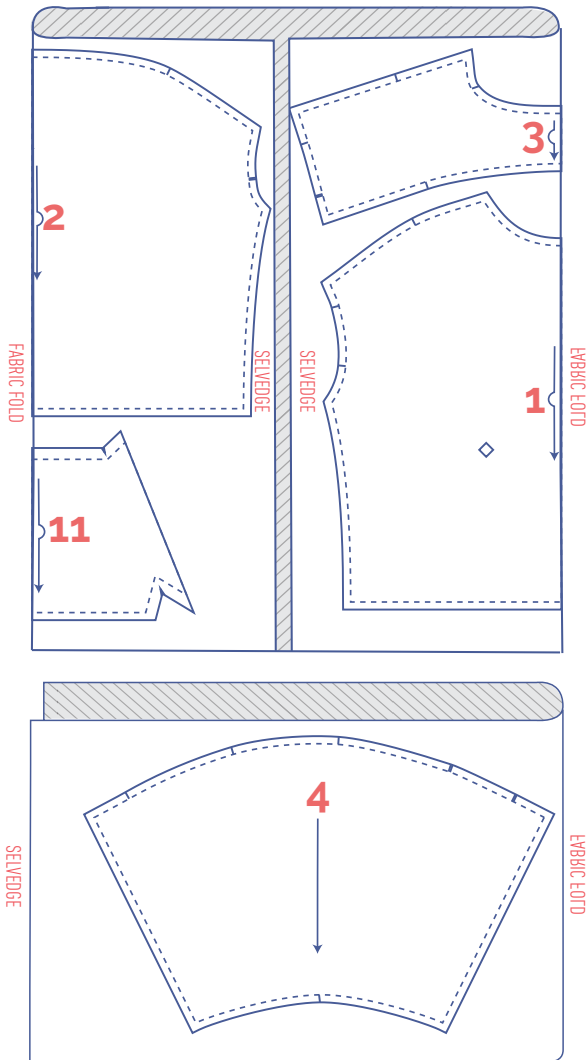

XL - XXL

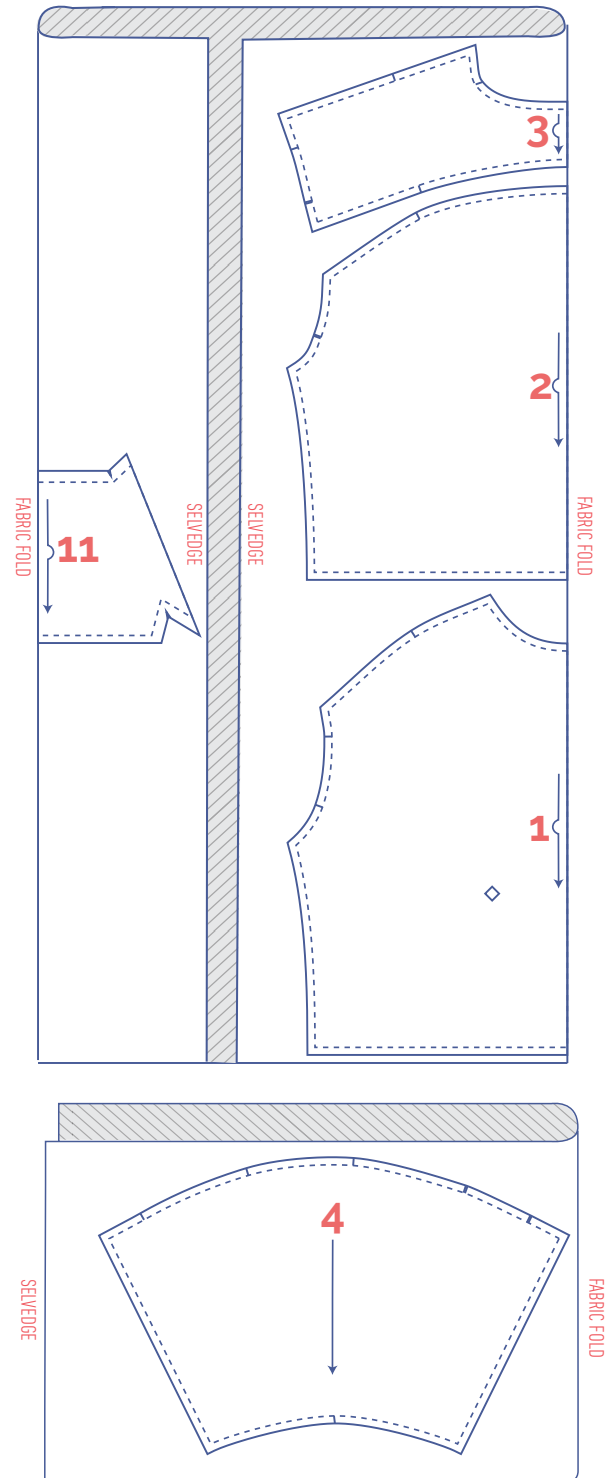

XXXL

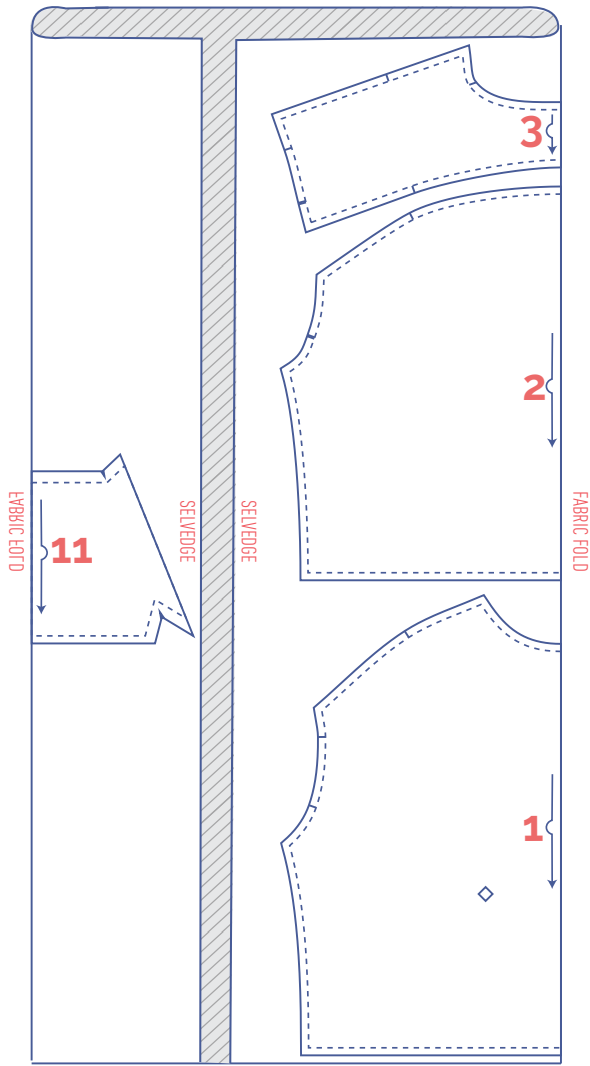

trim fabric layout

XS - S

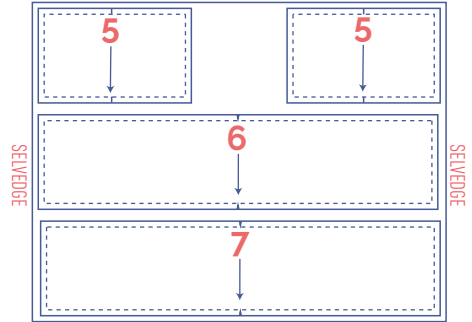

M - XXXL

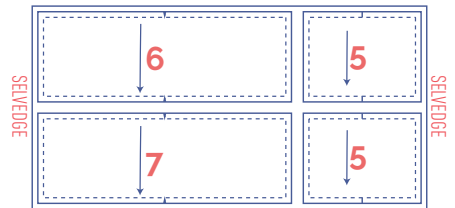

+

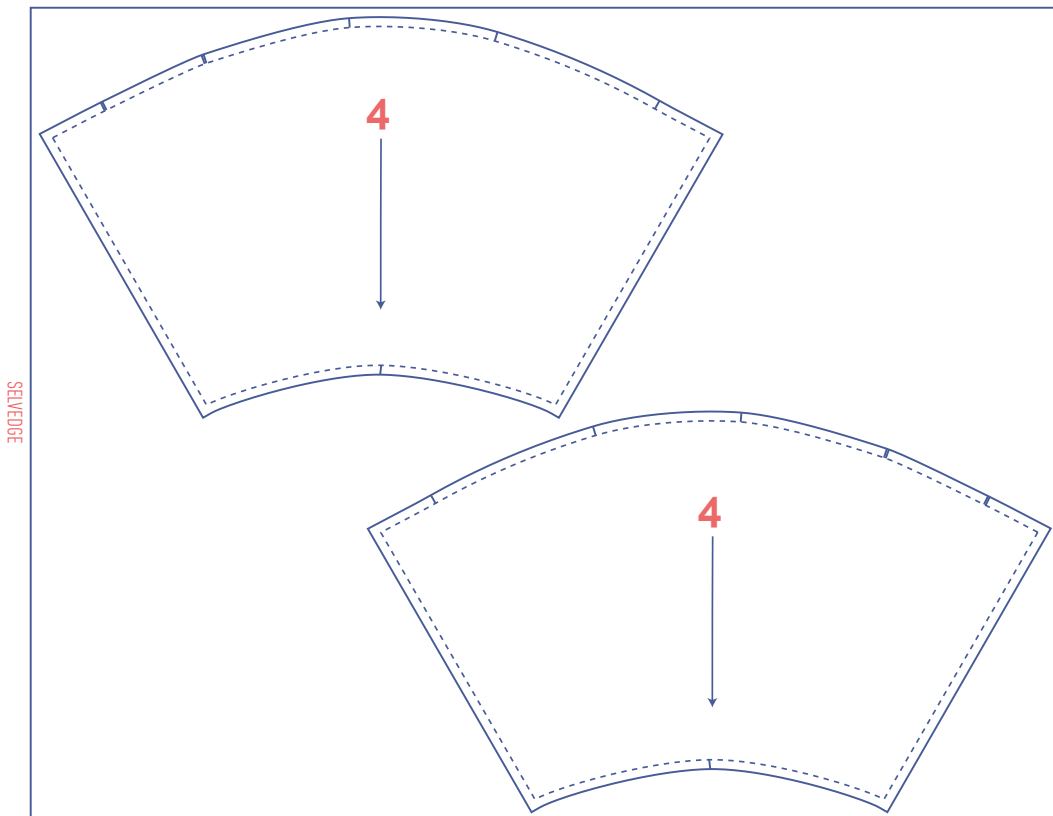

fabric layout – solid fabrics
fabric width 110 cm

hoodie version

XS - XXXL

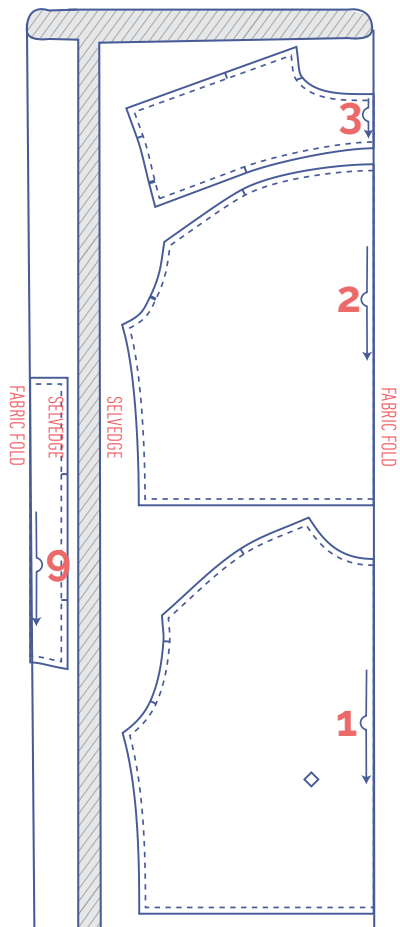

+

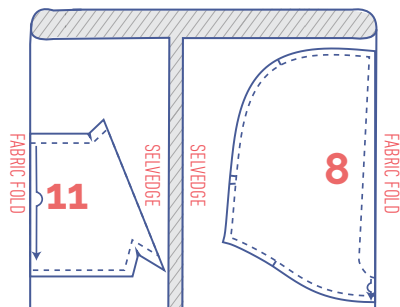
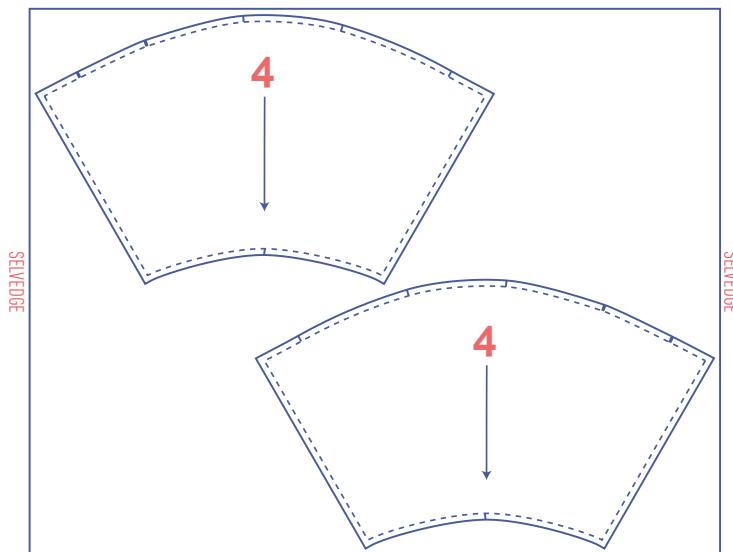

trim fabric layout

XS - XXXL

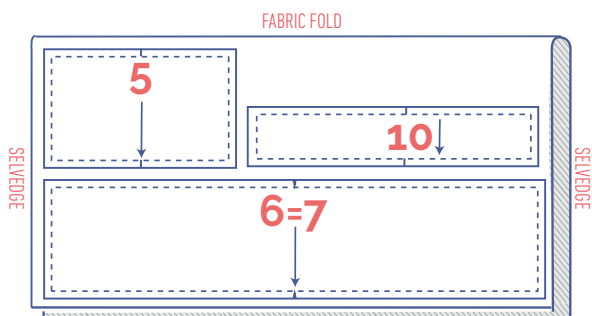

fabric layout – solid fabrics
fabric width 140 cm

hoodie version

XS - XXL

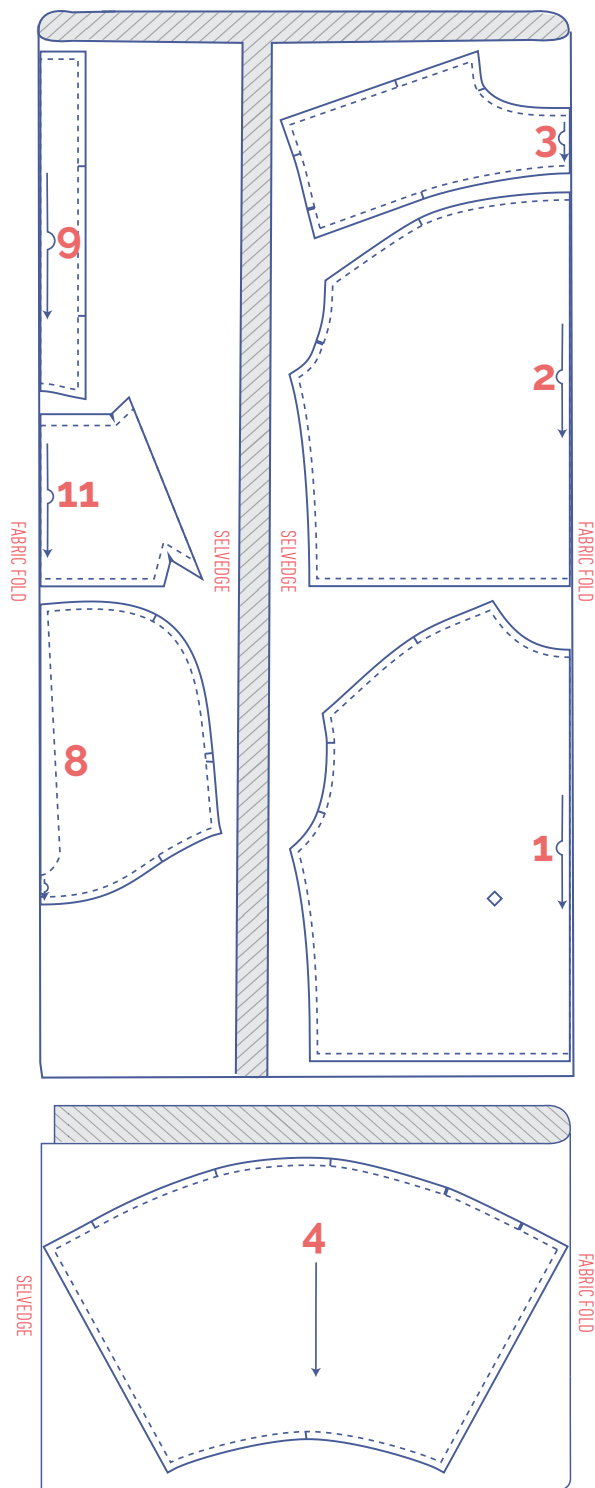

marking pattern pieces

| | |
|---|--|
| | notch the pattern paper and fabric at the following points |
| | single notch |
| | double notch |
| V | V notch |
| | mark the following points using marking thread |
| | centre point |

XXXL

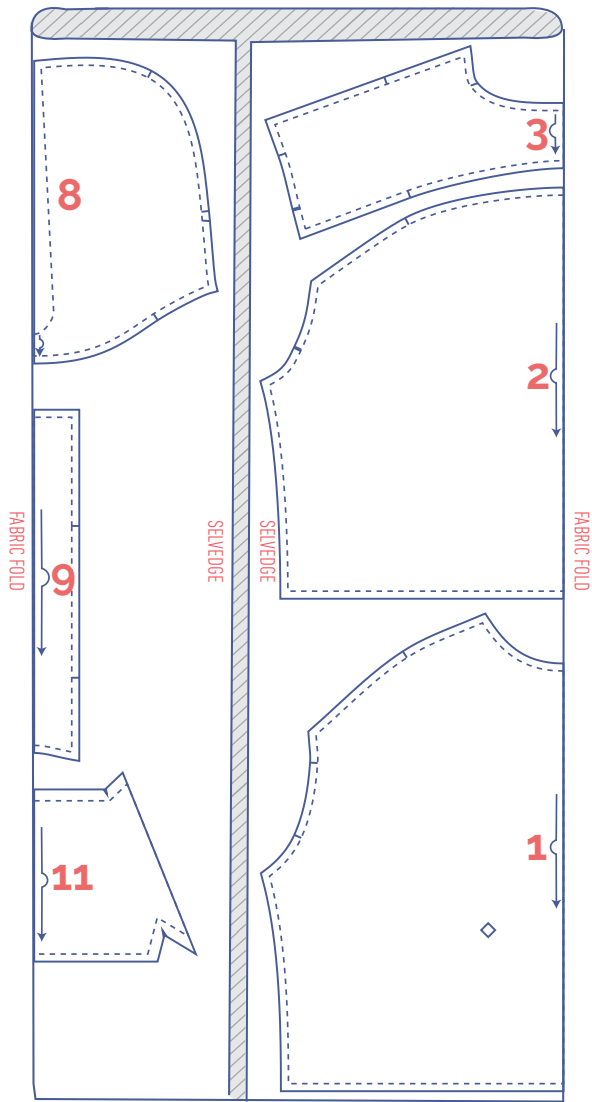

trim fabric layout

XS - XXXL

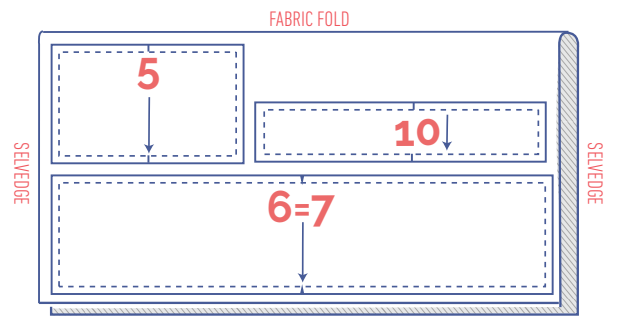

+

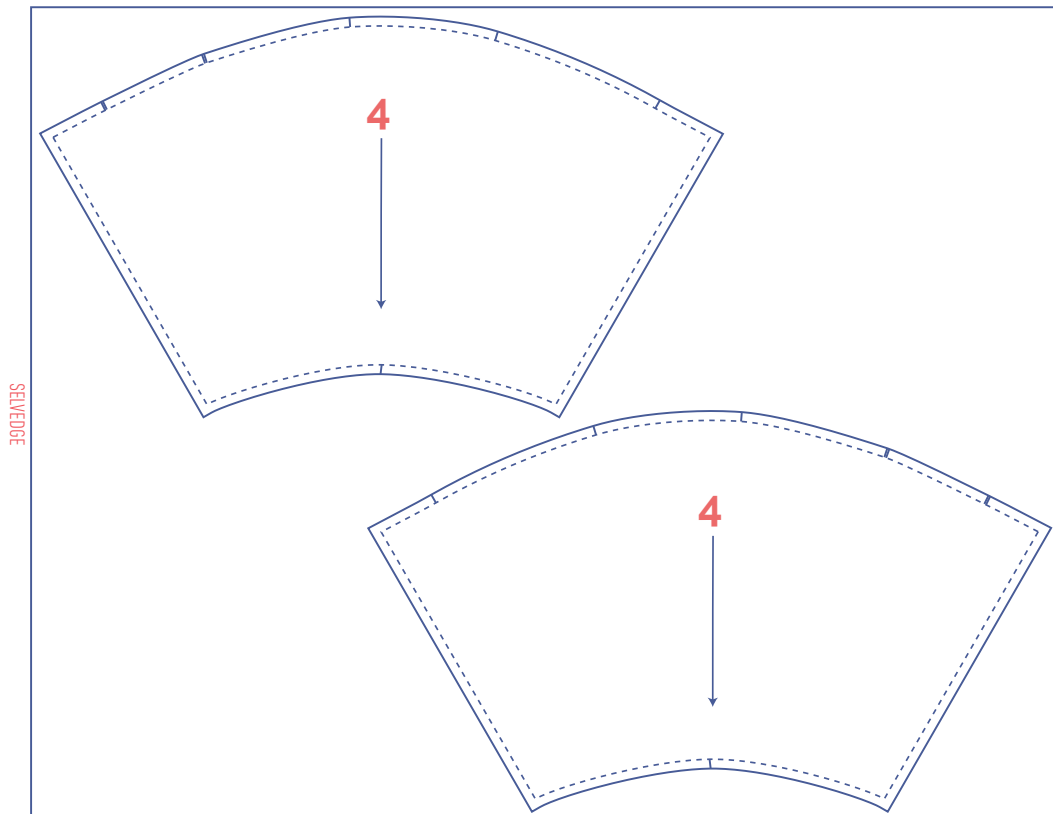

sewing instructions



The sewing instructions explain how to make the jumper if you don't have an overlocker. Select a stretch stitch on your sewing machine to sew the seams and an overlock stitch to finish the raw edges. However, the jumper can also be sewn entirely with a fourthread overlocker, i.e. 2 upper looper threads and 2 lower looper threads. The raw edges and seams are sewn together at the same time, which keeps the seams stretchy. The kangaroo pocket is always sewn with a standard straight stitch.



F front

B back

CF centre front

CB centre back

 right side

 wrong side

 iron-on interfacing

 trim fabric

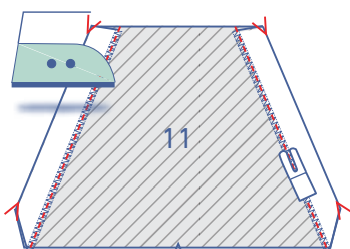
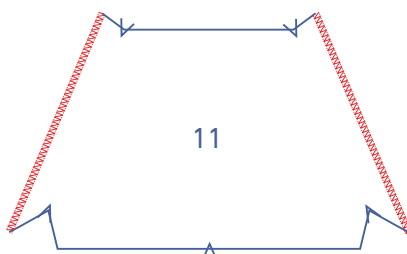
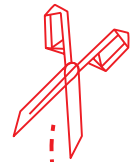

1

Optional

Finish the slanted end of the pocket pieces (11) with overlock stitching.

Press the slanted ends towards the wrong side at the V notches and sew into place.

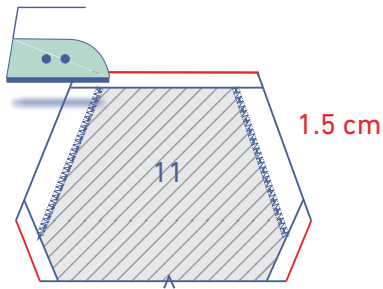

Press the ends 1.5 cm towards the wrong side where indicated.

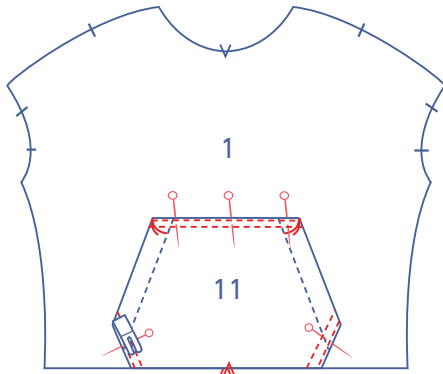

Pin the pocket to the front (1) where indicated and sew into place right next to the edge. Sew a second line of stitching at presser foot width from the first.

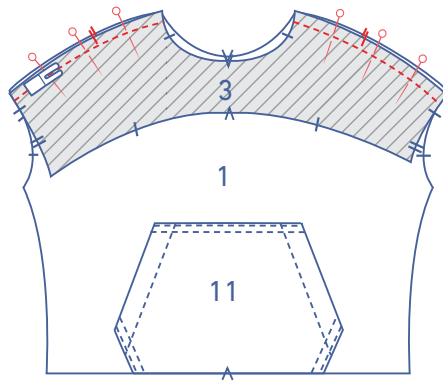

2

Pin and sew the yoke (3) to the front, matching the notches.

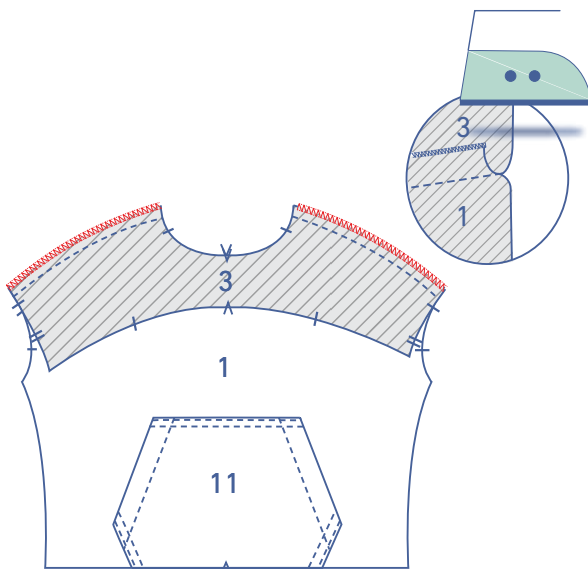

Finish the raw edges with overlock stitching and press towards the yoke.

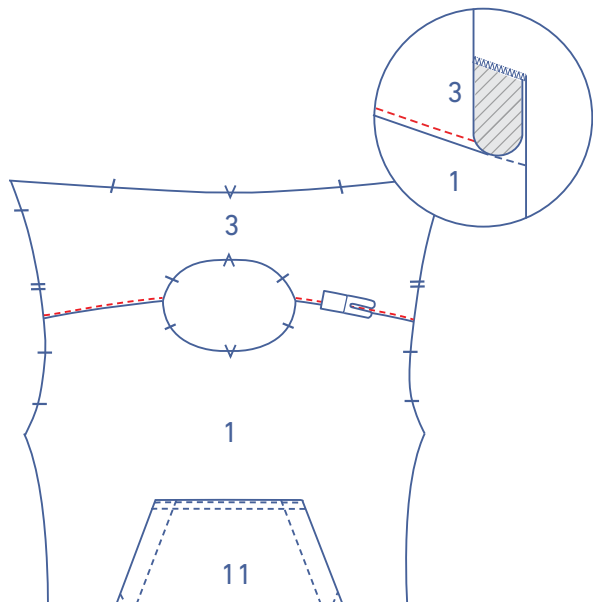

Sew the yoke to the seam allowance underneath, right next to the edge.

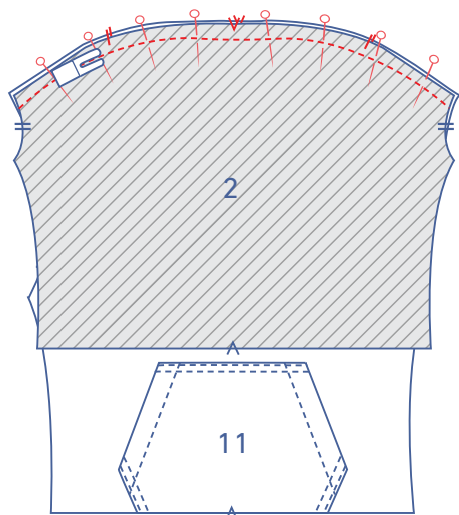

3

Pin and sew the yoke to the back (2), matching the notches.

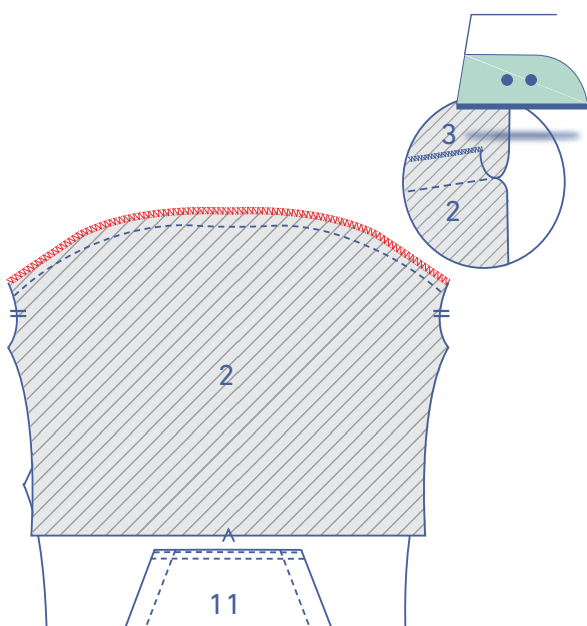

Finish the raw edges with overlock stitching and press towards the yoke.

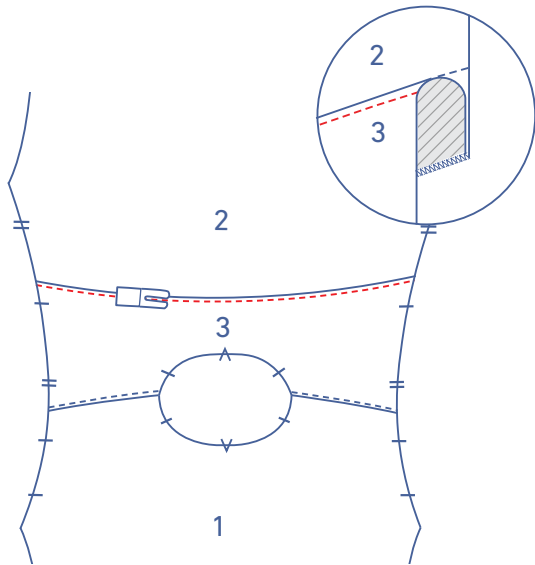

Sew the yoke to the seam allowance underneath, right next to the edge.

4.1

hoodless version

(skip to 4.2. for the hoodie version)

Open the pre-pressed bias tape out and press flat.

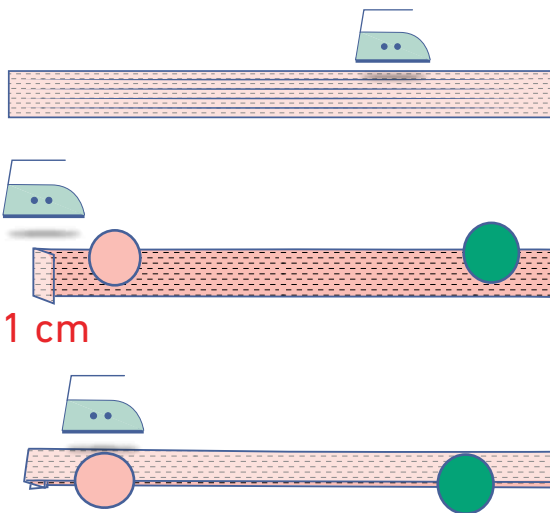

Press one short end of the bias tape 1 cm towards the wrong side. This pressed short end is marked with a pink circle. The unpressed short end has been marked with a green circle.

Press the bias tape in half lengthwise with the wrong sides of the fabric facing.

Pin the raw edges of the bias tape to the right side of the neckline. Place the folded end at CB. The unfolded end (green circle) of the bias tape should be on top of the folded end.

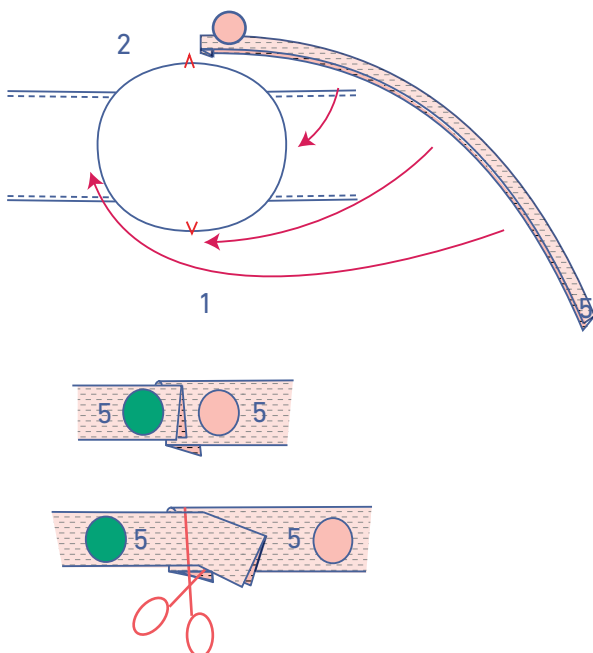

Snip off any excess bias tape.

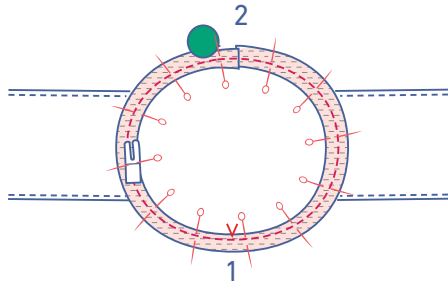

Sew the bias tape into place at 1 cm from the raw edge.

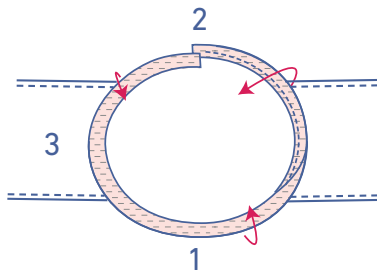

Fold the bias tape and seam allowance over and stitch the bias tape to the seam allowance underneath, right next to the seam.

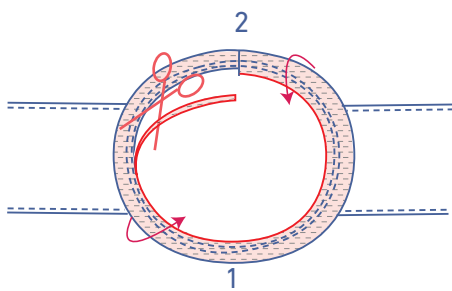
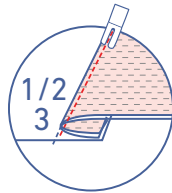
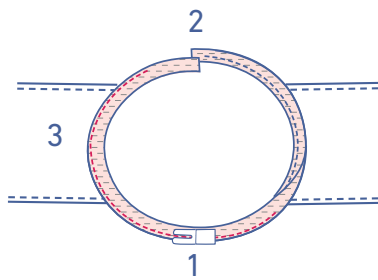

Trim any excess seam allowance.

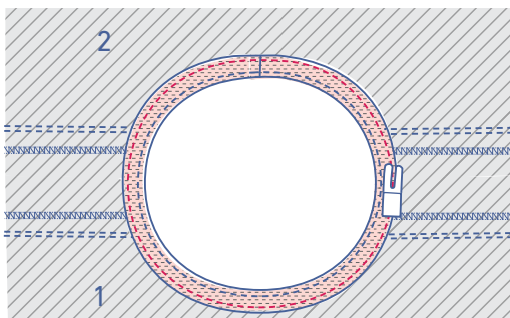

Press the bias tape all the way over to the wrong side. Stitch into place right next to the edge.

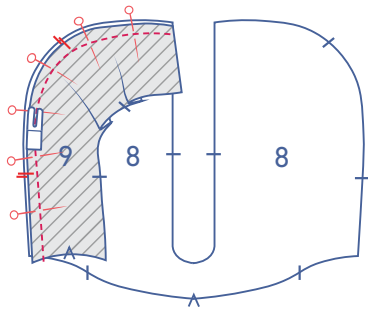

4.2

hoodie version

Pin and sew the long ends of the middle section of the hood (9) to the ends of the hood (8) indicated, matching the notches.

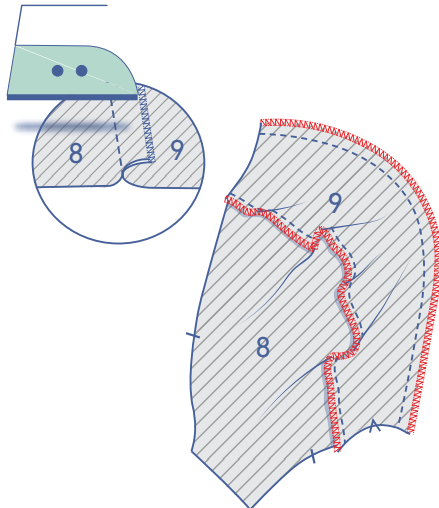
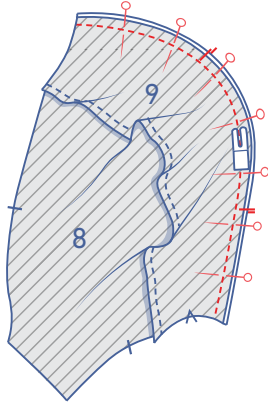

Finish the raw edges with overlock stitching and press the seam allowance towards the middle section.

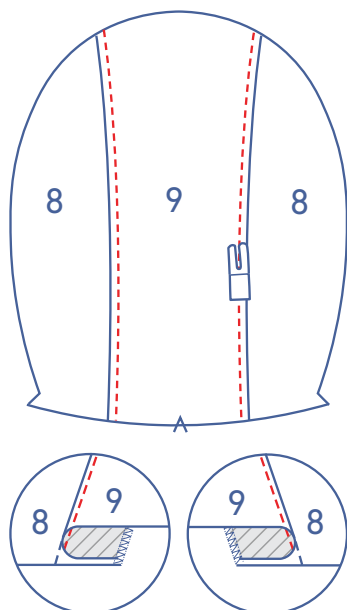

Sew the middle section to the seam allowance underneath, right next to the seam.

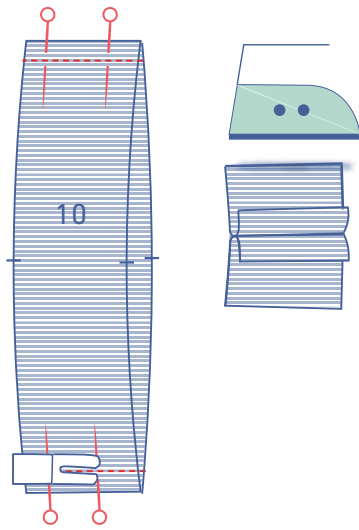

Pin and sew the short ends of both hood trim pieces (10) together.

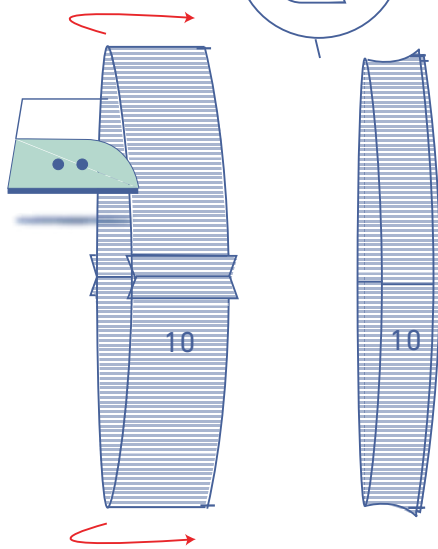
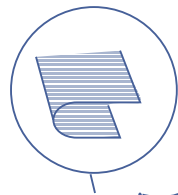

Fold the hood trim in half with the long ends together and the wrong sides of the fabric facing.

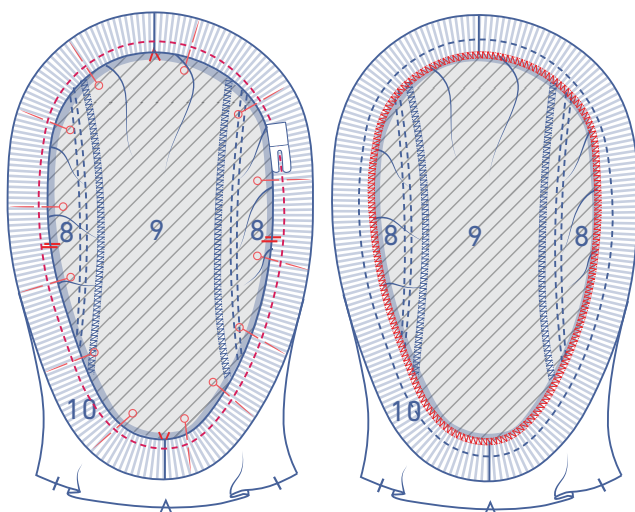

Pin and sew both raw edges of the hood trim to the hood, making sure the seams of the trim line up with the V notches in the middle section of the hood and the hood itself. The circumference of the hood trim is a little bit smaller than the circumference of the hood, so stretch out the hood trim as you sew.

Finish the raw edges with overlock stitching.

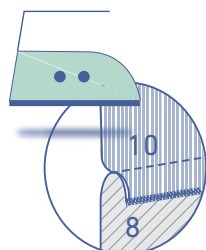

Press the seam allowance towards the hood.

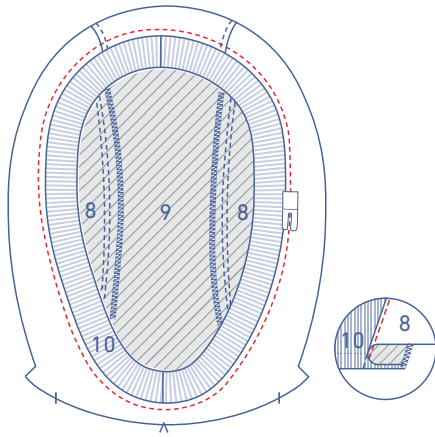

Sew the hood to the seam allowance underneath, right next to the edge.

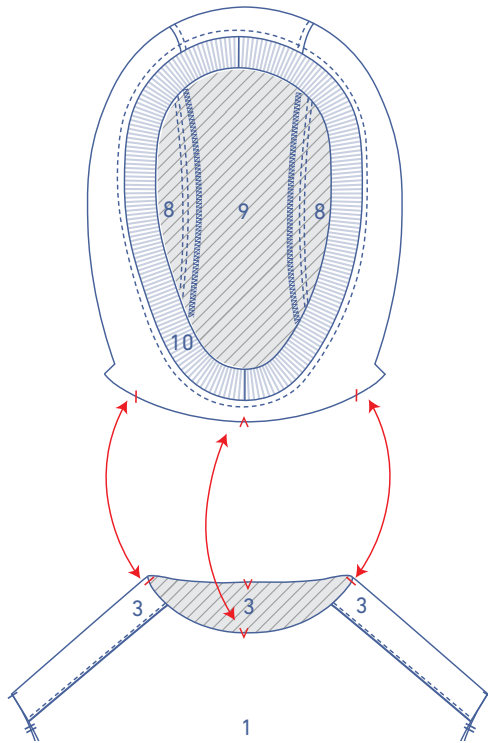

Pin and sew the hood to the neckline, right sides together and matching notches.

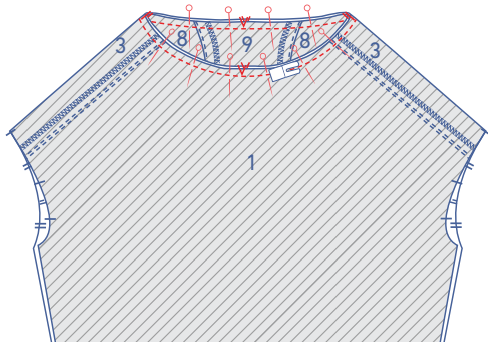

Finish the raw edges with overlock stitching.

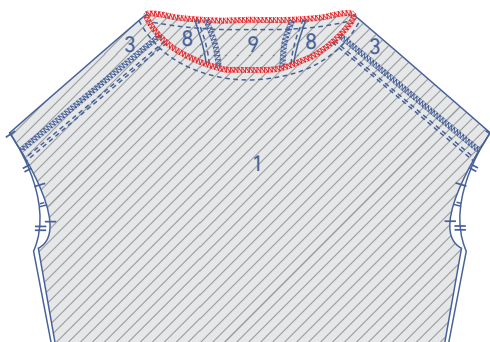

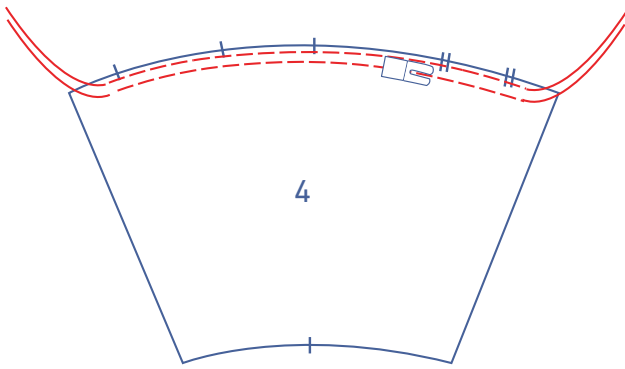

Using a long stitch length and a low thread tension, sew 2 parallel lines of stitching to the top of the sleeve (4). Leave a length of thread at the start and end of the stitching.

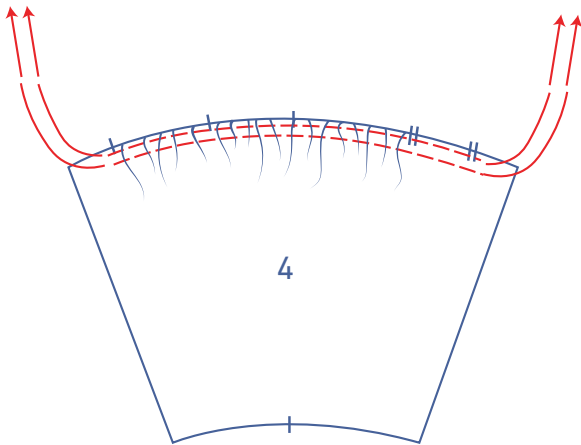

Carefully tug the ends of the threads to gather the fabric.

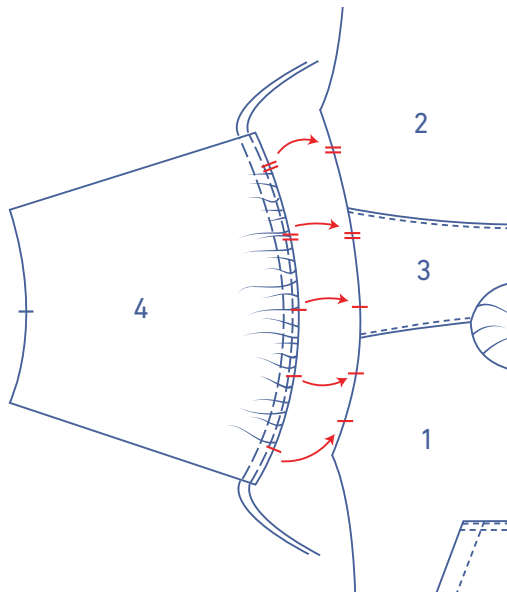

Distribute the gathers so that the sleeve notches match those of the garment.

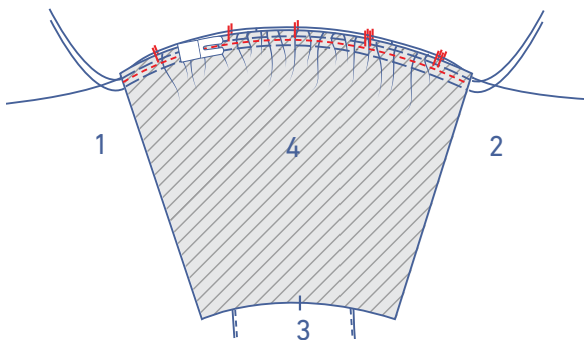

Pin and sew the sleeve to the garment, matching the notches.

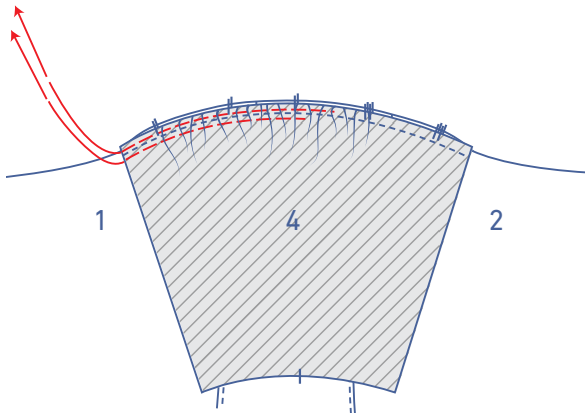

Remove the gathering threads.

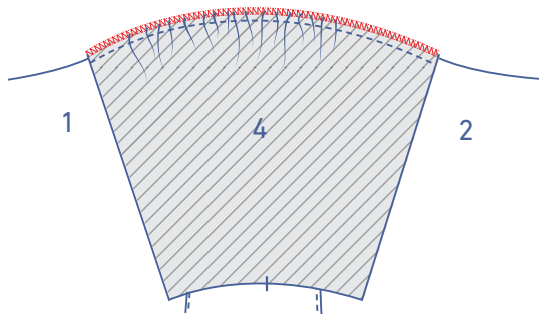

Finish the raw edges with overlock stitching.

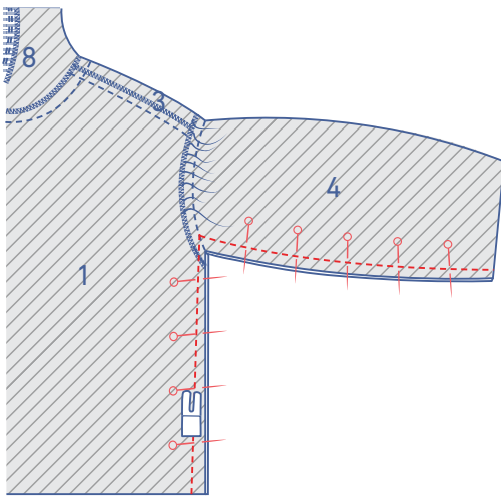

6

Pin and sew the side and underarm seams.

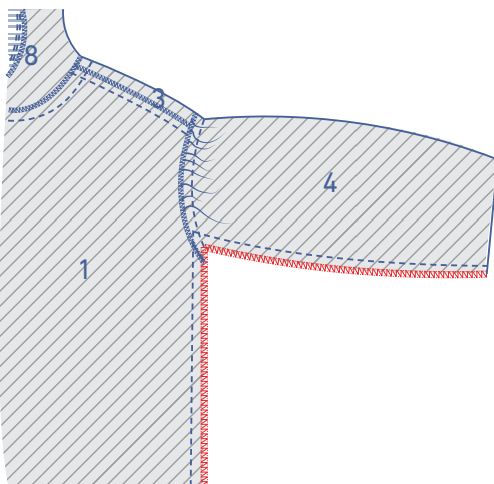

Finish the raw edges with overlock stitching.

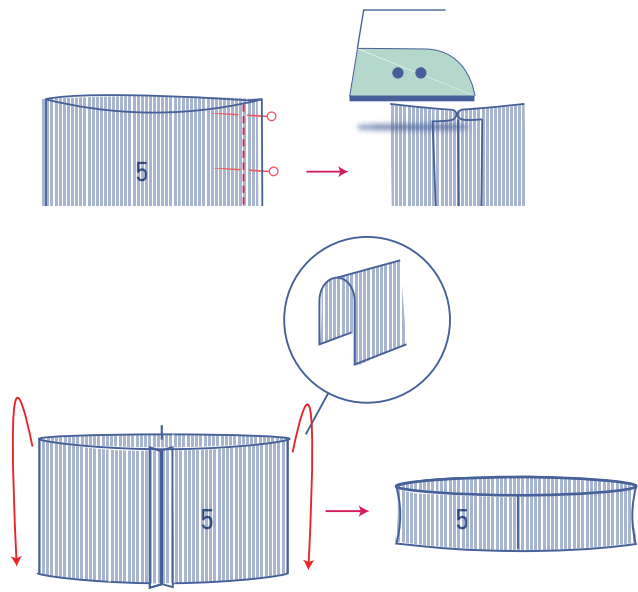

7

Fold the wrist trim (5) in half with the short ends together and the right sides of the fabric facing. Sew the seam and press the seam allowance open.

Fold the wrist trim in half with the long ends together and the wrong sides of the fabric facing.

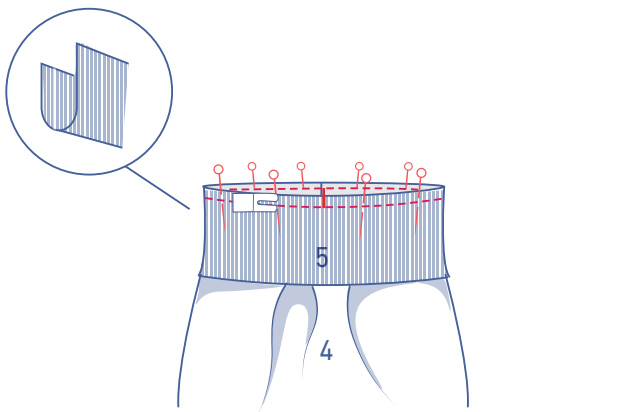

Slide the wrist trim over the bottom of the sleeve so that all raw edges are aligned, making sure the seams and notches match. The circumference of the wrist trim is smaller than the sleeve hem, so stretch out the wrist trim as you sew.

Finish the raw edges with overlock stitching.

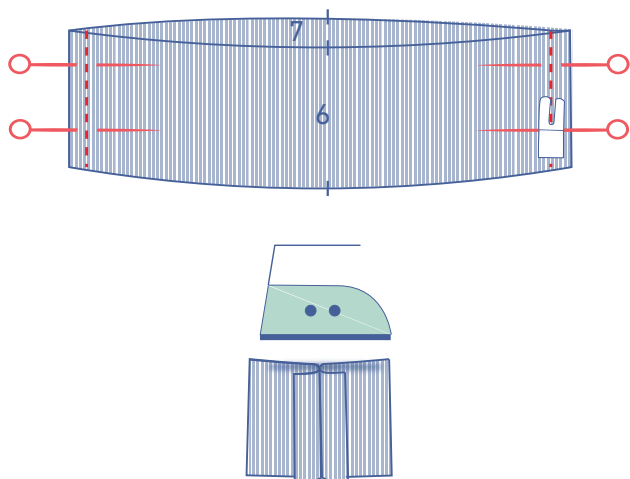
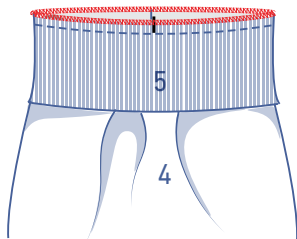

8

Pin and sew the side seams of the hem band front (6) and hem band back (7) together and press the seam allowance open.

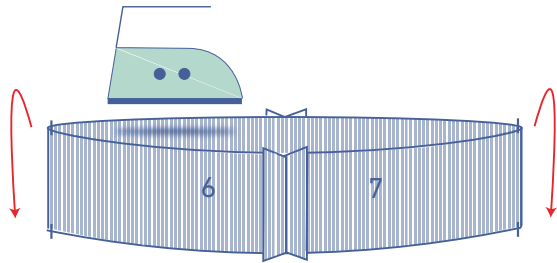

Press the hem band in half with the long ends together and the wrong sides of the fabric facing.

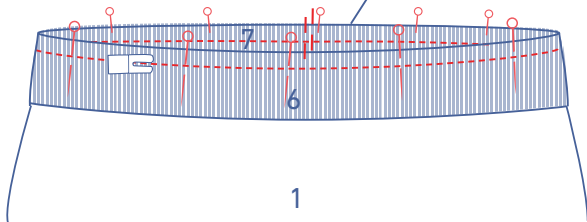
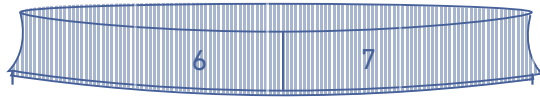

Slide the hem band over the bottom of the jumper so that all the raw edges are aligned. Pin and sew, making sure the seams and markings match. The circumference of the hem band is smaller than the circumference of the jumper so stretch out the hem band as you sew. For the version with the pocket, be sure to catch the bottom of the pocket when you sew.

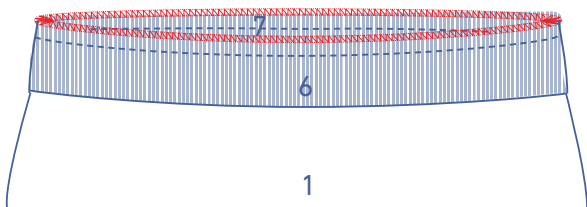

Finish the raw edges with overlock stitching.