

Olive by Fibre ⚡ood



Olive by Fibre ood



4 - 32

If you're a 'ruffles' kind of gal, then Olive is a must. Casually elegant is the phrase that springs to mind. Olive lets you decide whether to show off your pretty neckline; adding the concealed zip or not is the secret.

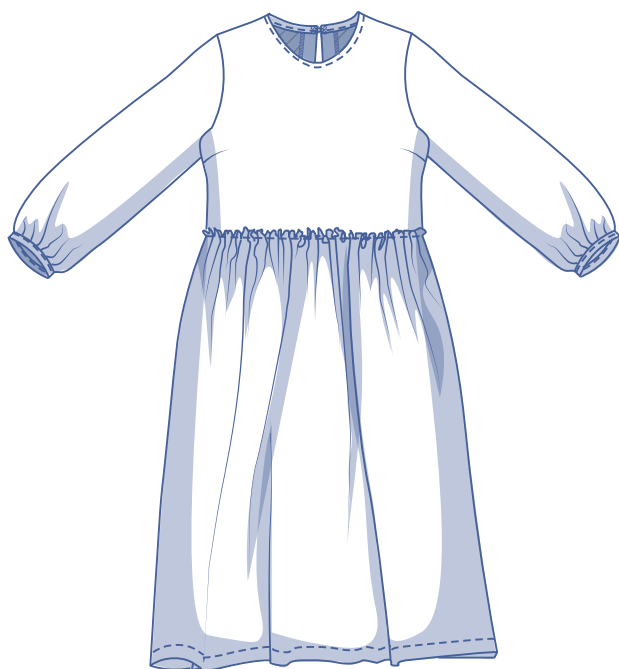
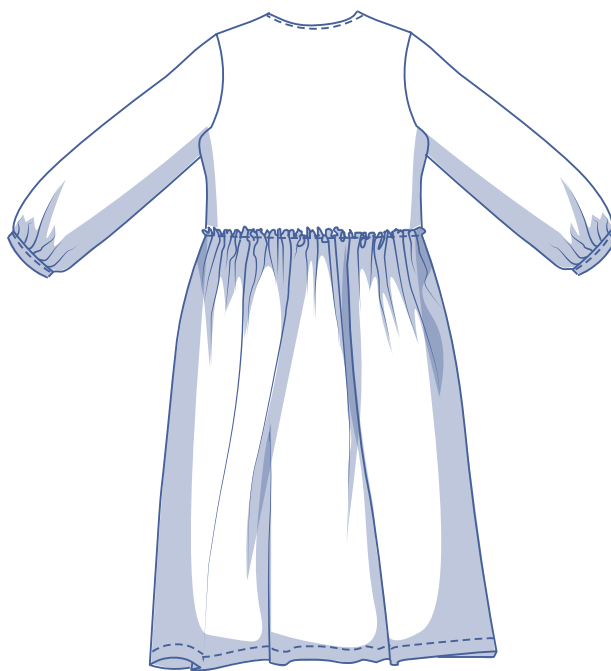
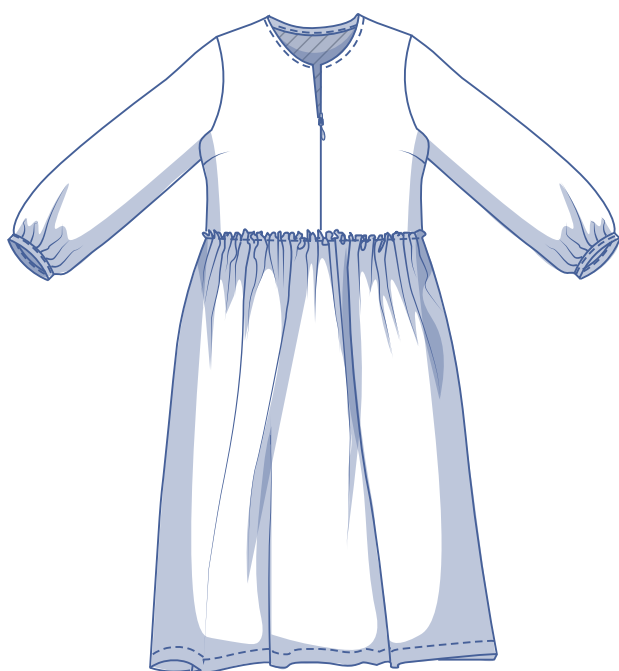

size chart (in cm)

size	4	6	8	10	12	14	16	18	20	22	24	26	28	30	32
body height	160	164	166	167	168	169	170	171	172	172	172	172	172	172	172
B (bust)	76	80	84	88	92	96	100	104	110	116	122	128	134	140	146
W (waist)	66	68	70	74	78	82	84	88	94.5	101	107.5	114	120.5	127	133.5
H (hips)	86	90	94	97	100	103	106	109	115	120	125	130	135	140	145

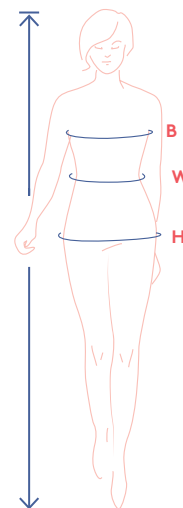

Choose your size based on your **bust measurement**. Select the size closest to your bust measurement. If your waist measurement is wider than what's listed in the size chart, check the size chart below to see if there is enough room or whether the pattern needs to be altered. It's easy to do. When tracing the pattern, simply trace from the line of one size to the line of the other. However, be careful to trace the line of the corresponding size for the skirt in order to fit the bodice.

pattern measurements (in cm)

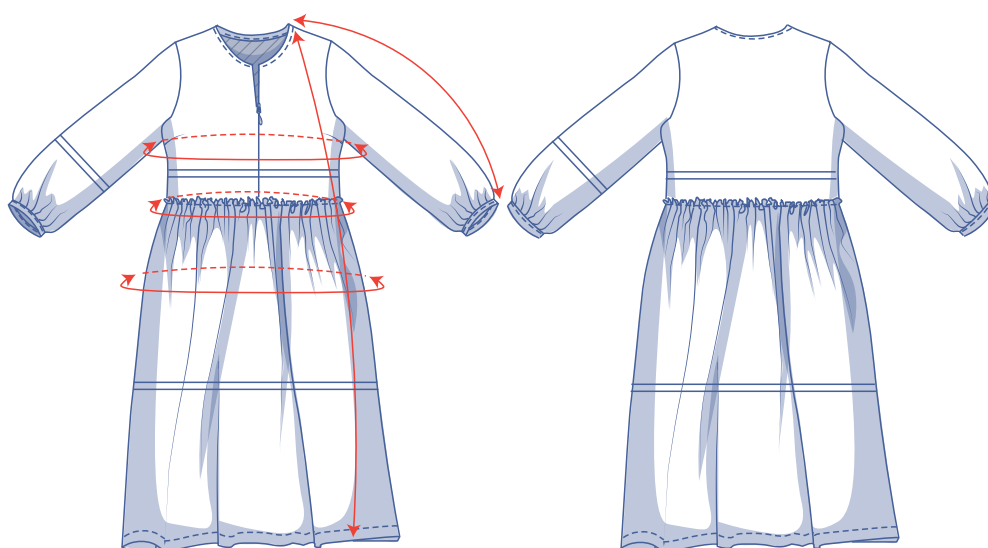

== shorten or lengthen the pattern here

This chart's measurements are the pattern measurements based on the fabric type and serve as a reference. Ease has been added to the width measurements (in addition to the exact body measurements) for a more comfortable fit. Olive is designed to be **fitted at the bust and relaxed at the hips**.

size	4	6	8	10	12	14	16	18	20	22	24	26	28	30	32
length	119.75	120.25	120.75	121.5	122	122.5	125	125.5	129.25	130	131	131.75	132.5	133.25	134
sleeve length*	68.75	69.25	69.5	69.75	70	70.25	70.75	71	71.5	71.75	72.25	72.5	73	73.5	73.75
bust	84.25	88	91.75	95.5	99.25	103	106.75	110.5	117.5	123	128.25	133.75	139.25	144.5	150
waistline measurement	80.75	82.75	84.75	88.75	92.75	96.75	98.75	102.75	109.25	115.75	122.25	128.75	135.25	141.75	141.75
hips**	138	141.5	145.25	152	158.75	165.5	169.25	176	186.75	197.5	208.5	219.25	230	240.75	251.5

* Including shoulder length and cuff.

** Including ruffle allowance.

Compare the stated lengths to the measured or desired lengths. **Lengthen** or **shorten** the dress and/or the sleeves by cutting the pattern pieces at the indicated double lines. Then either increase the distance between the cut pieces by the desired amount (to lengthen) or overlap the pieces (to shorten). Make sure that the CF and CB lines and the side seams are always straight.



IMPORTANT

Adjust the amount of fabric to be used based on these alterations.

notions



- Thread
- Iron-on interfacing: max. 20 cm
- Invisible zip: 20 cm (version without keyhole in the CB)
- Hook-and-eye closure (version without invisible zip in the CF)
- Fabric: see table

fabric		4	6	8	10	12	14	16	18	20	22	24	26	28	30	32
fabric width 110 cm	cm	285	285	290	290	295	310	315	320	335	350	355	420	435	450	460
fabric width 140 cm	cm	230	235	235	240	275	285	295	295	325	330	330	335	335	340	345

The corresponding fabric layout can be found on page 6 of these sewing instructions.

fabric advice Olive looks a treat in all kinds of fabrics from fluid drape to structured and somewhat heavier fabrics. Whether you go fluid or structured depends on the look you hope to achieve. Poplin, leather(ette) and chambray are some structured options. If you'd like Olive in something drapier, go for silk (satin), lyocell, crepe, double gauze, etc. Olive's finest features shine brightest in a solid fabric or a delicate print like pinstripes.



Proud to be #Sewista

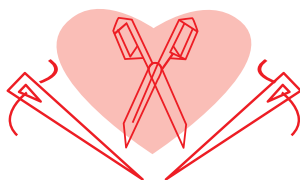

pattern pieces & seam allowances (in cm)

To sew the garment as described in the instructions, draw the illustrated seam allowances around the paper pattern pieces before cutting them out. If you are using a PDF pattern, the pattern can be printed with or without seam allowance. To find out more, watch the [video](#).

- | | |
|-----------------------------------|-------------------------------|
| 1. bodice front: 2x | 5. sleeve: 2x |
| 2. bodice back: 1x on fabric fold | 6. cuff: 2x |
| 3. skirt front: 1x on fabric fold | 7. bias tape: 1x |
| 4. skirt back: 1x on fabric fold | 8. facing back: 2x (optional) |

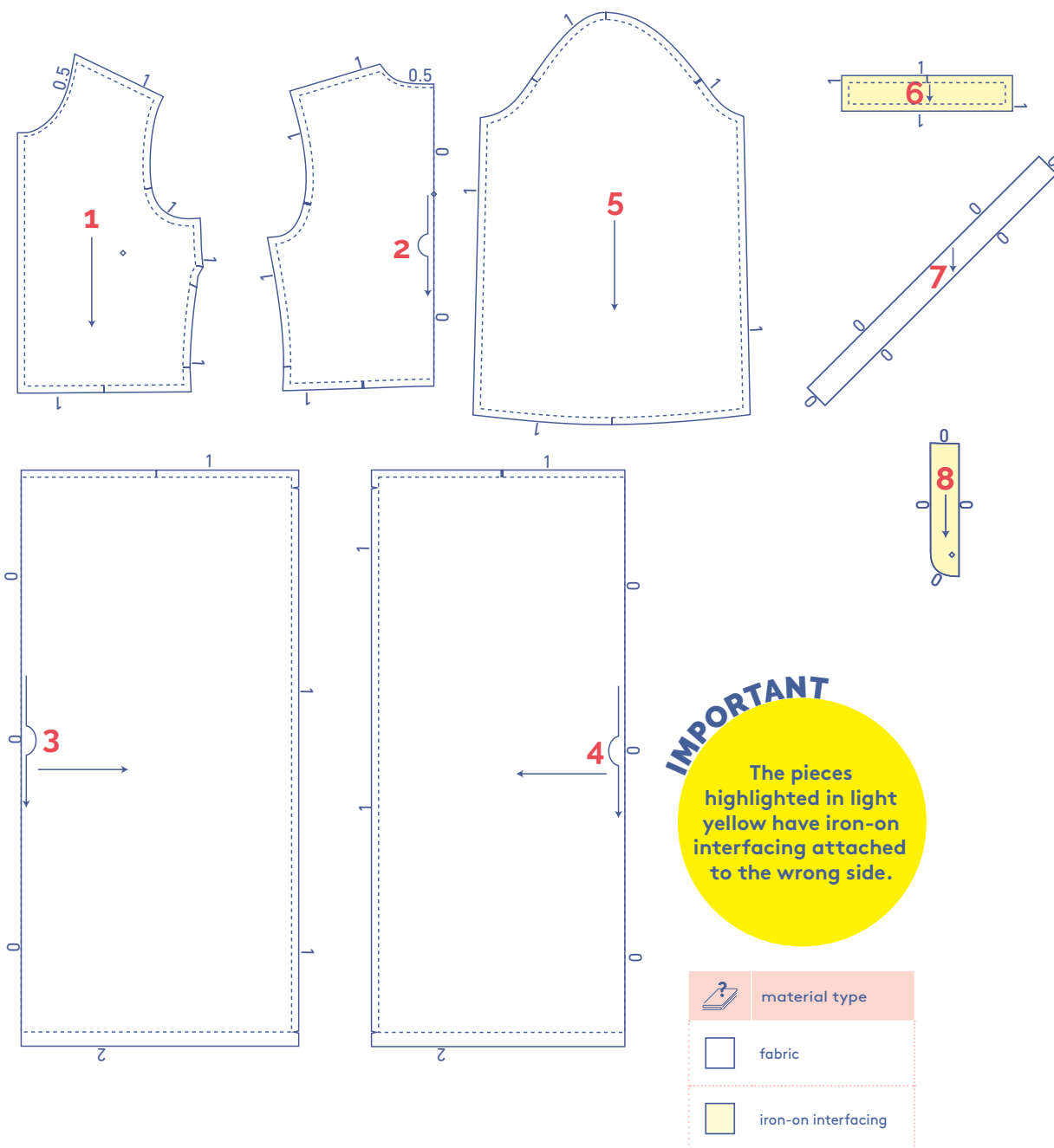

NOTE

There are two versions of Olive, one with an invisible zip in the CF seam and one without. Use pattern pieces 1 through 7 as stated for the version **with an invisible zip** in the CF seam. Use pattern pieces 1 through 8 as stated for the version **without an invisible zip** in the CF seam. Then cut pattern piece 1 on the fabric fold once (remember to remove the 1 cm extra of seam allowance at the CF) and pattern piece 2 twice (but add 1 cm extra seam allowance at the CB).

fabric layout – solid fabrics
fabric width 110 cm

4 - 12

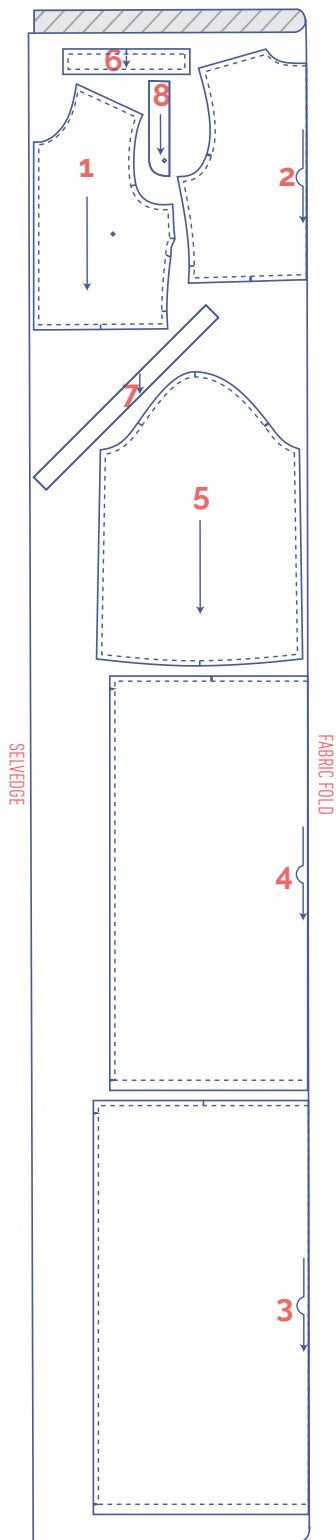

IMPORTANT

You only need pattern piece 7 once.

14 - 24

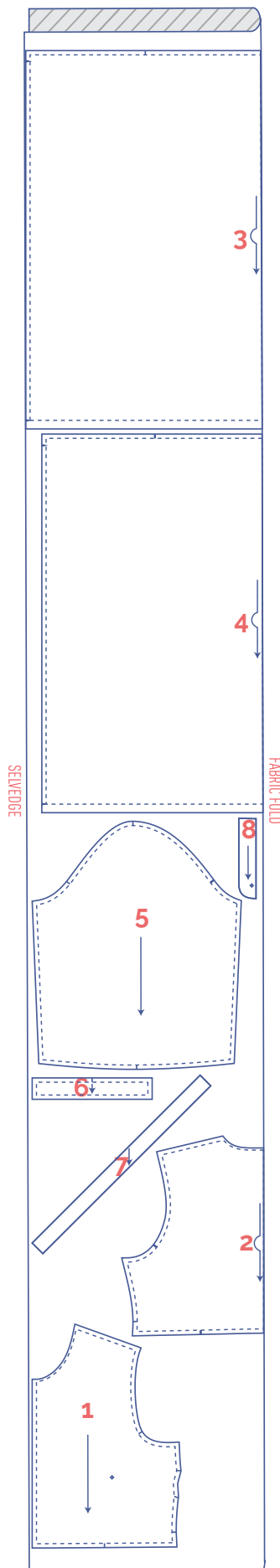

IMPORTANT

You only need pattern piece 7 once.

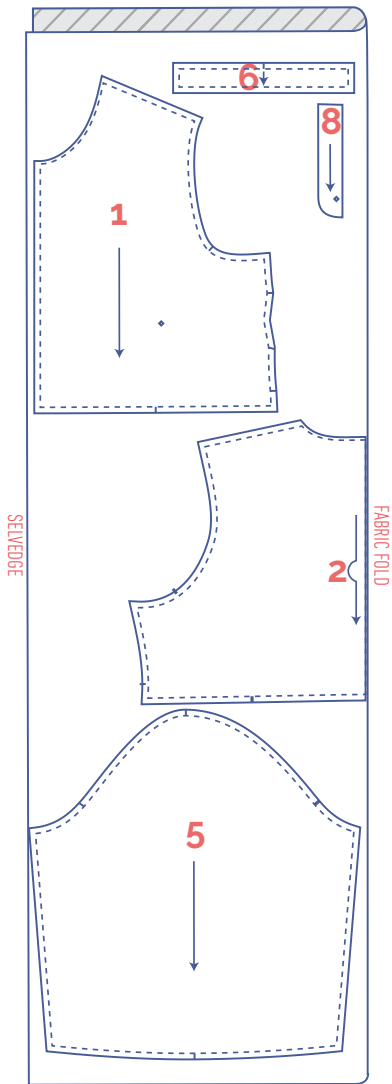

+

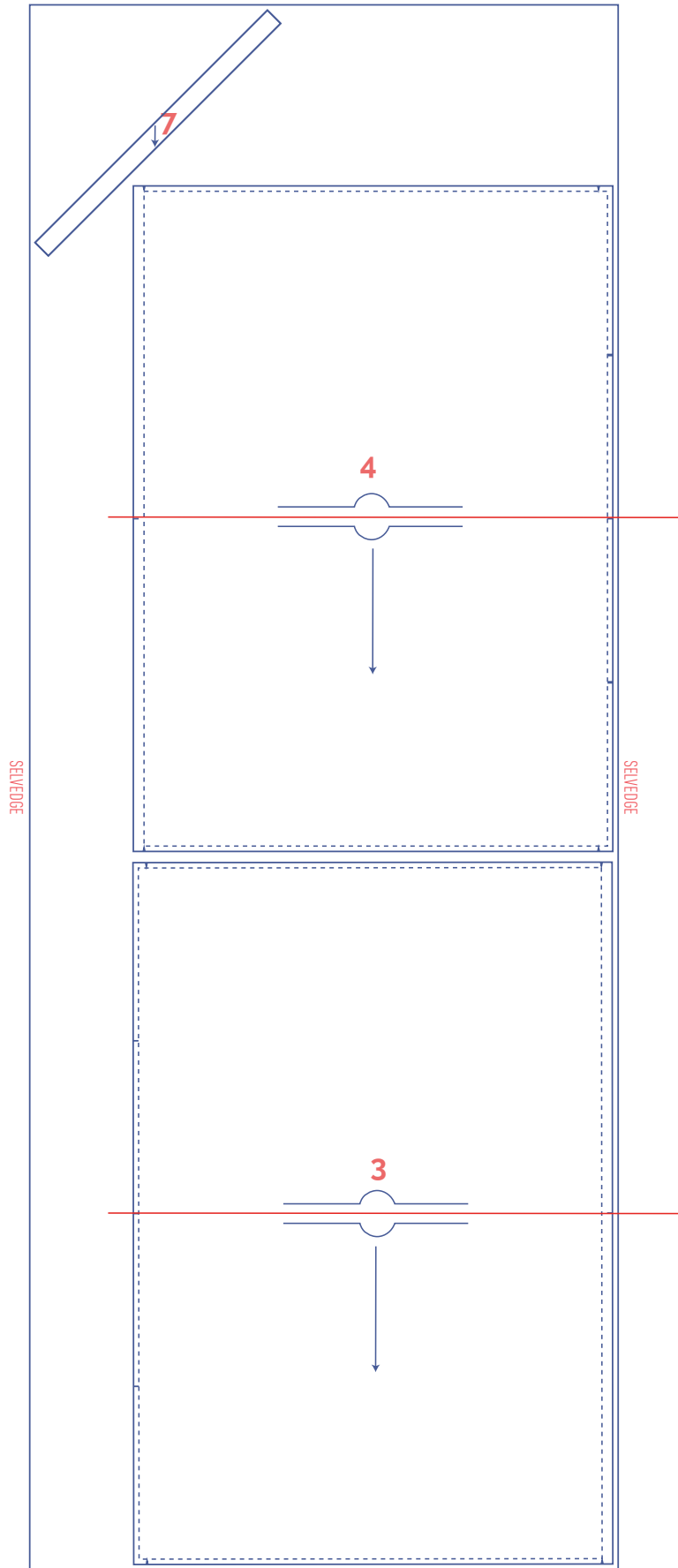

IMPORTANT

Pattern pieces 3 and 4 have been rotated at a 90° angle to fit on the fabric. This may give you a little trouble if your fabric is patterned or has a nap.

fabric layout – solid fabrics
fabric width 140 cm

4 - 10

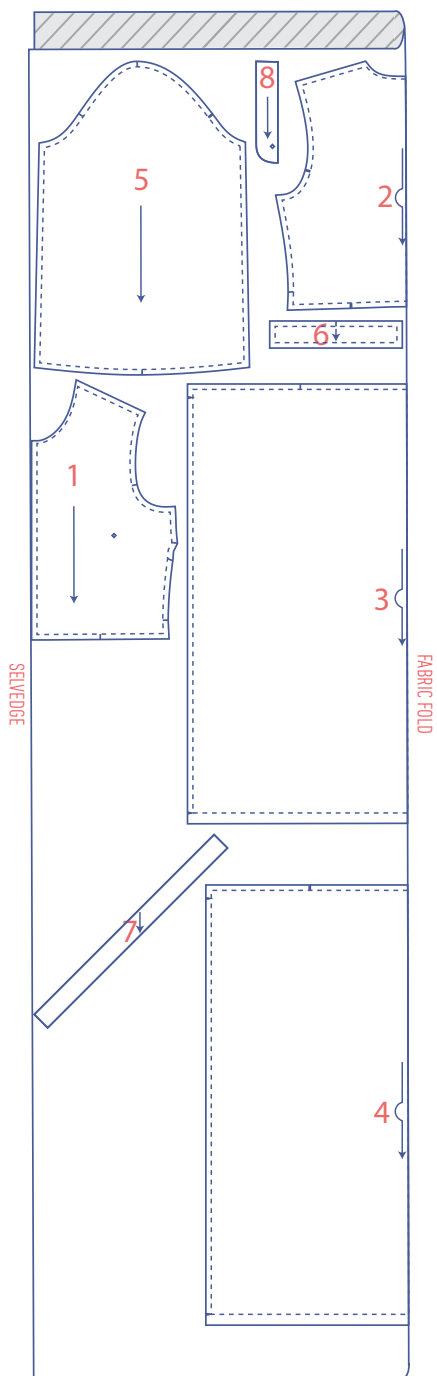

IMPORTANT

You only need pattern piece 7 once.

12 - 32

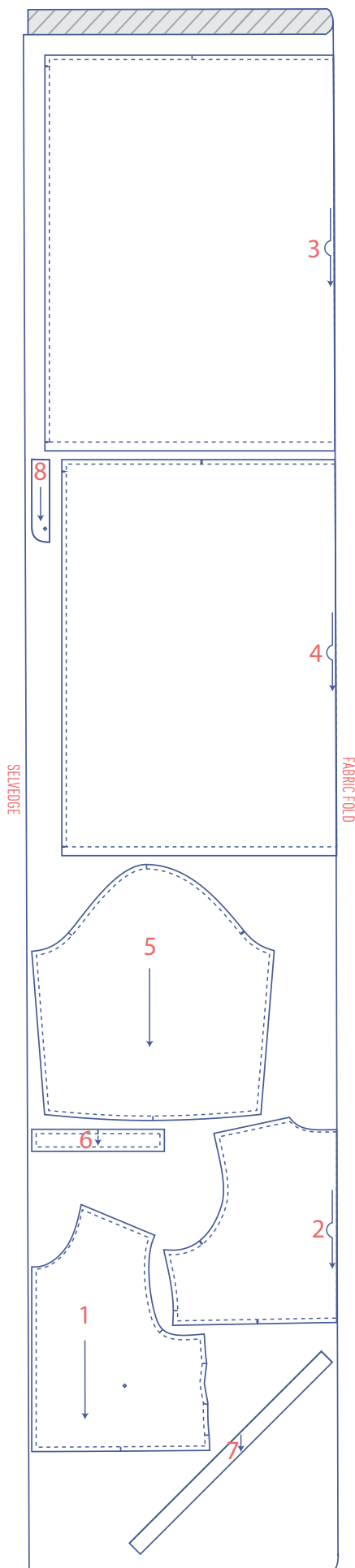

IMPORTANT

You only need pattern piece 7 once.

marking pattern pieces



Notch the pattern paper and fabric at the following points



single notch



double notch



V notch



Mark the following points using marking thread







centre point

sewing instructions



The method used to finish the seams depends on the fabric used. The pieces are always sewn together with the right sides of the fabric facing, unless stated otherwise.



F	front
B	back
RF	right front ●
LF	left front ●
CF	centre front
CB	centre back
	right side
	wrong side
	iron-on interfacing

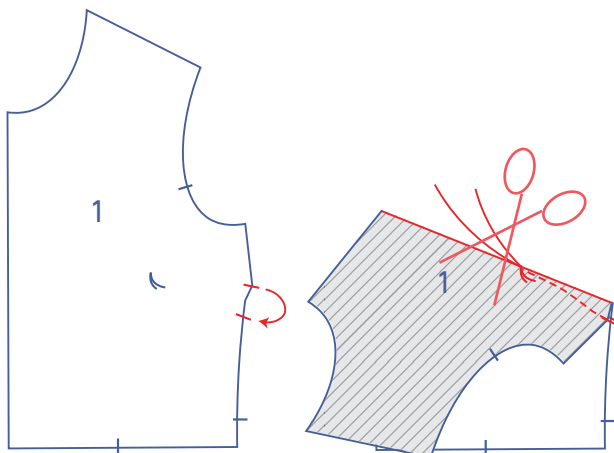
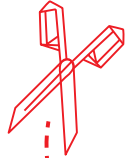

1

Fold the bodice at the notches in the bodice front (1) side seam, right sides together. Sew the dart or contour in a slightly curved line towards the marking thread. Stitch up to and just past the marking thread, so that you've sewn past the fabric. Snip the threads and make a knot.

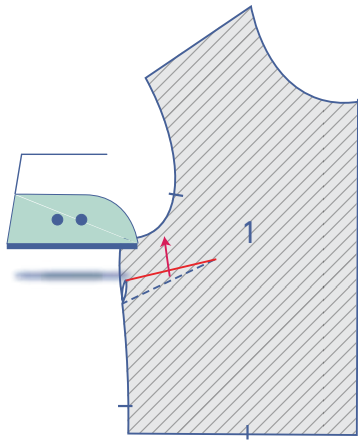

Turn the bodice front over so that the right side is facing down. Press the dart upwards towards the armhole.

2.1 Version 1 (zip in CF)

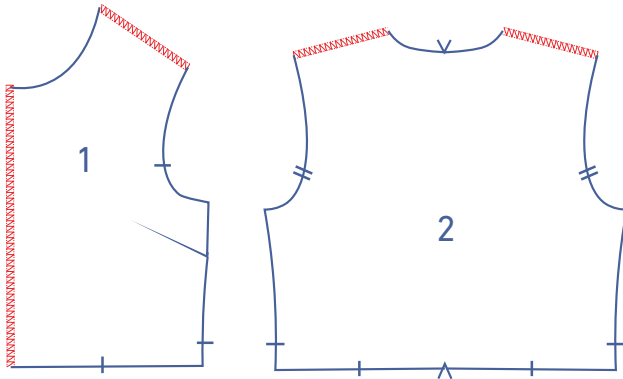

Finish the shoulders of the bodice front and bodice back (2) with overlock stitching where indicated. Also finish the CF on the bodice front.

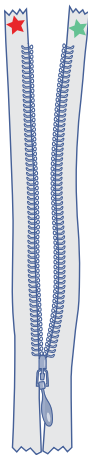

Place the invisible zip in front of you with the right side facing up. Open the zip.

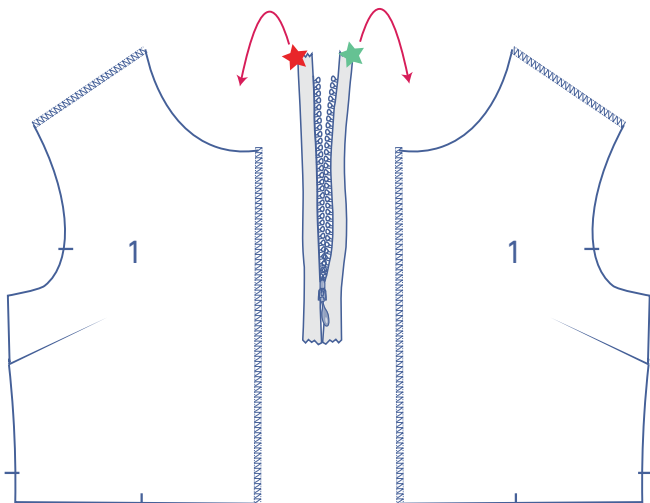

Place both bodice front pieces in front of you with the right sides facing up.

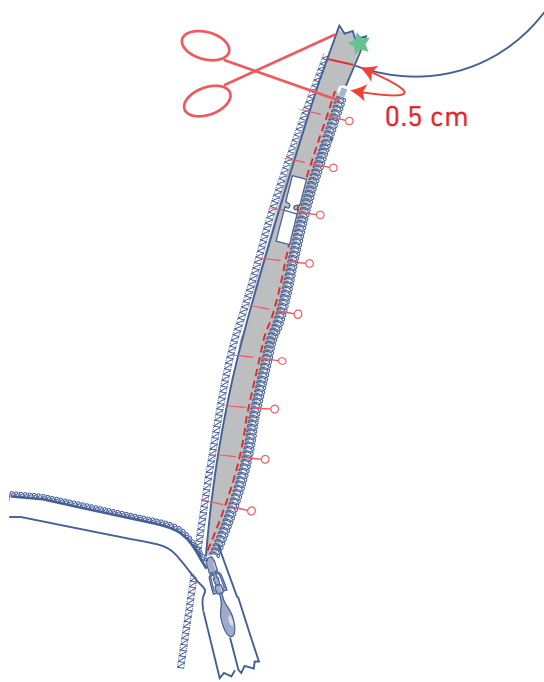

Fold the green star zip tape over to the right and pin to the CF line. The zip tape should be next to the overlocking, and the zip teeth should be 0.5 cm under the raw edge of the neckline. Trim the top of the zip tape so that it matches the raw edge of the neckline. This will prevent any bunching. Sew into place with the invisible zipper foot.

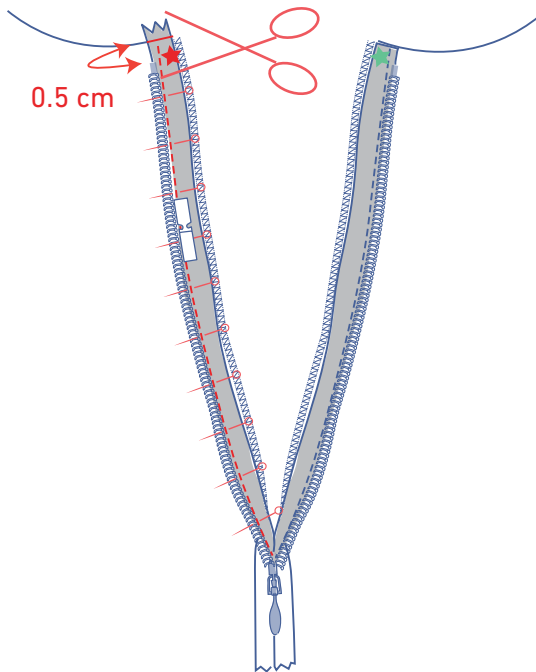

Fold the red star zip tape over to the left and pin to the CF line. The zip tape should be next to the overlocking. The zip teeth should be 0.5 cm under the raw edge of the neckline. Trim the top of the zip tape so that it matches the raw edge of the neckline. This will prevent any bunching. Sew into place with the invisible zipper foot.

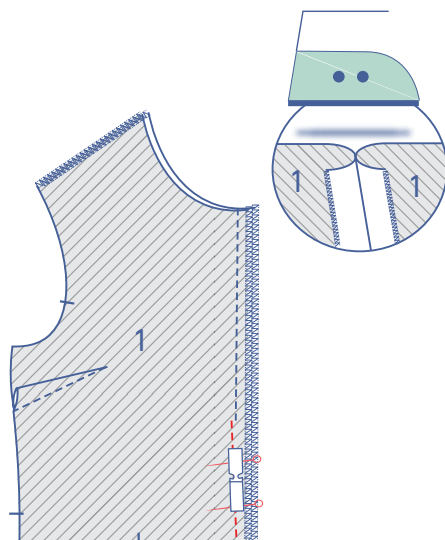

Close the zip and sew the rest of the CF seam with the narrow presser foot or the zipper foot. Start sewing slightly above and right next to your previous stitching (to sew the zip tapes). Press the seam allowance open.

2.2 Version 2 (no zip in CF)

Finish the edges of the bodice front, bodice back (2), and facing (8) with overlock stitching where indicated.

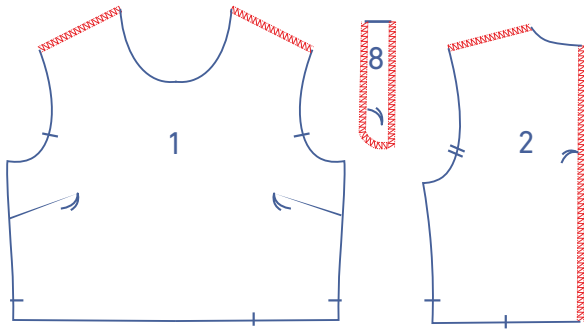

Pin the facing to the bodice back. Sew into place up to the marking threads.

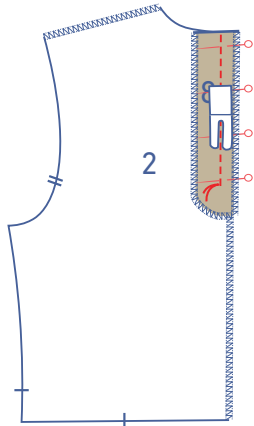

Fold the facing and seam allowance over. Stitch the facing to the seam allowance underneath, right next to the seam.

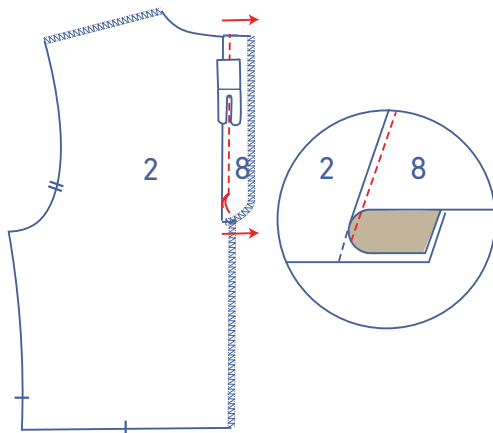

Place the back bodice pieces on top of each other, right sides together. Pin and sew the CB seam from the marking threads to the bottom. Press the seam allowance open.

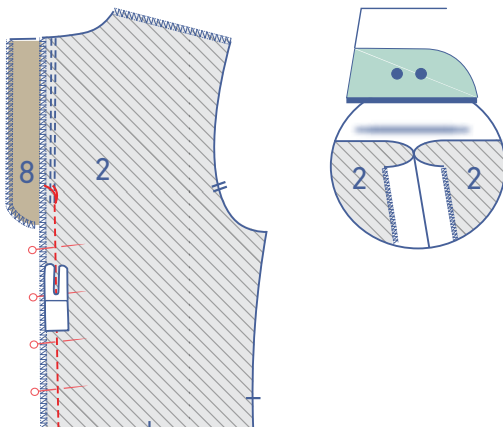

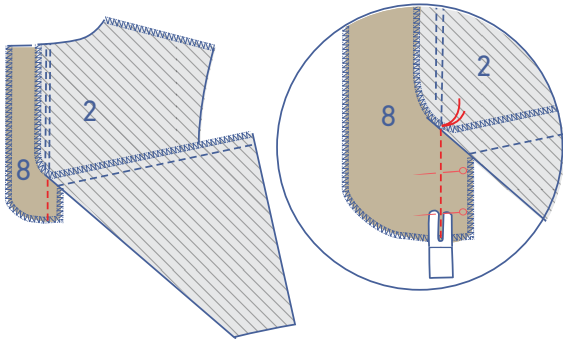

Move the back bodice out of the way. Pin and sew the interfaced pieces together as well from the marking threads to the bottom.

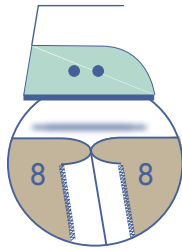

Press the seam allowance open.

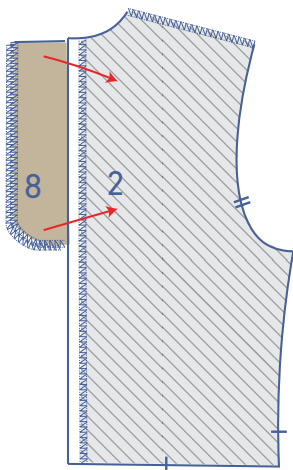

Now, fold the facing all the way over to the wrong side of the back.

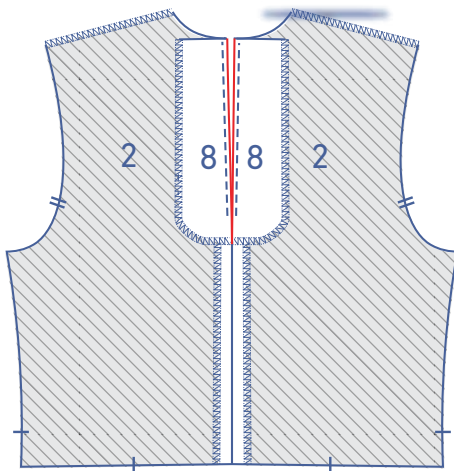
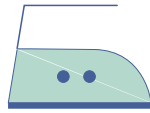

Press neatly flat.

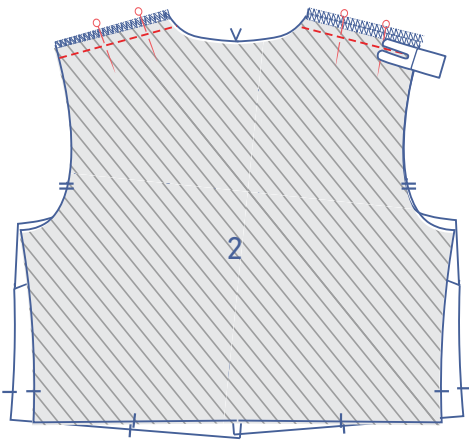

3

Pin and sew the shoulder seams together.

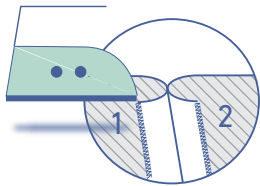
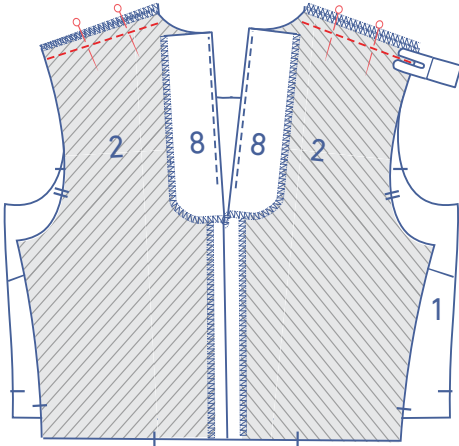

Press the seam allowance open.

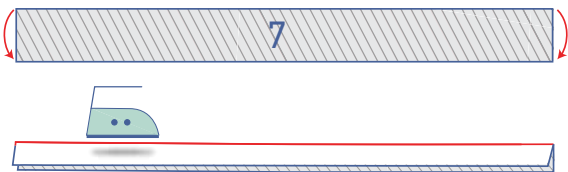

4

4.1 Version 1 (zip in CF)

Fold the bias tape (7) in half with the long ends of the tape together and the wrong sides of the fabric touching.

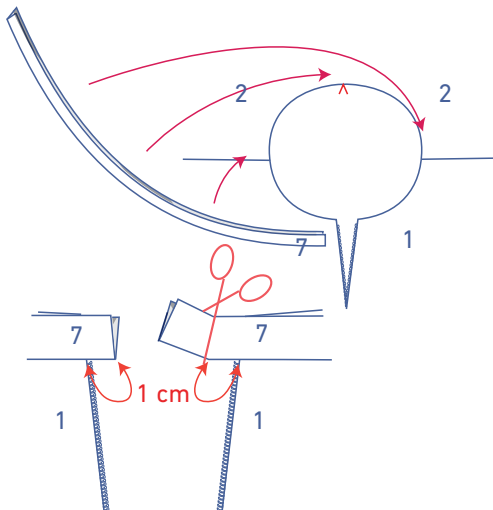

First, pin the bias tape to the right side of the neckline to determine the correct length of the bias tape. Cut off any excess, but retaining an extra 1 cm of seam allowance for each short end. (Providing the exact length is tricky because the grain line is on the bias, i.e. it will differ according to fabric type.) Unpin the bias tape.



Fold the bias tape in half with the long ends together and the right sides of the tape facing. Sew the short ends closed.

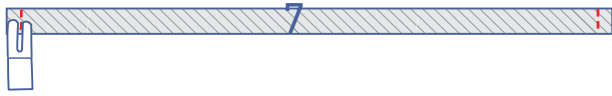

Turn the bias tape the right way out.

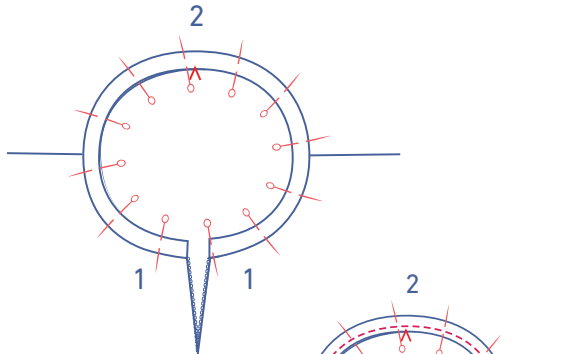

Re-pin both raw edges of the bias tape to the right side of the neckline. The finished ends should match the finished CF lines.

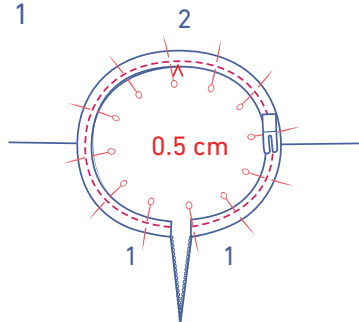

Sew into place at 0.5 cm.

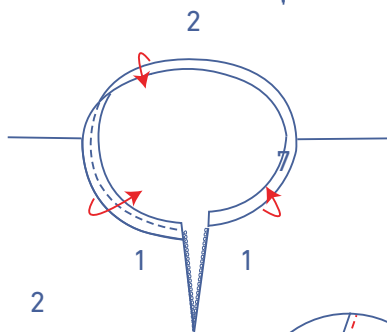

Fold the bias tape over and stitch the bias tape to the seam allowance underneath, right next to the seam.

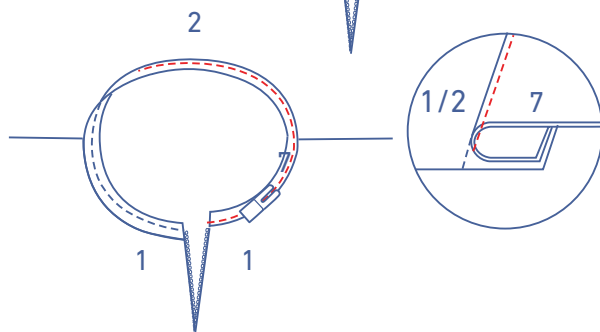

Fold the bias tape all the way over to the wrong side and edgestitch into place.

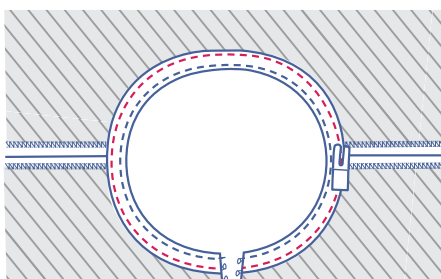

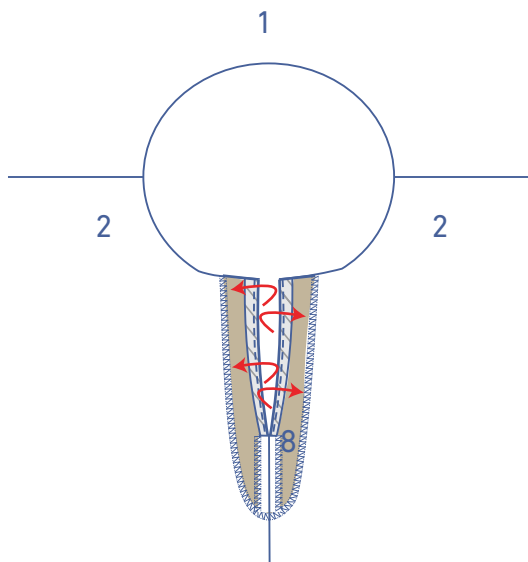

4.2 Version 2 (no zip in CF)

Fold the interfaced pieces at the top of the CB over to the right side of the bodice back.

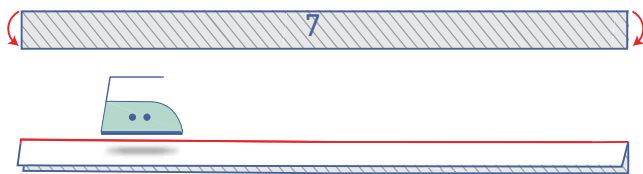

Fold the bias tape (7) in half with the long ends of the tape together and the wrong sides of the fabric touching.

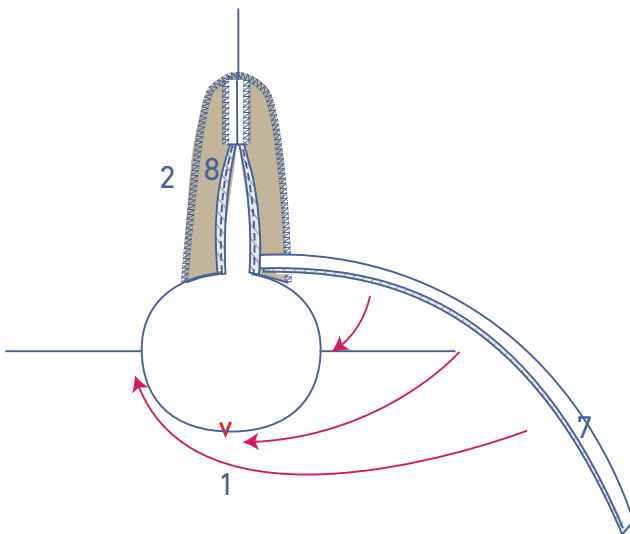

Pin the bias tape to the right side of the neckline, matching raw edges of the bias tape to the neckline.

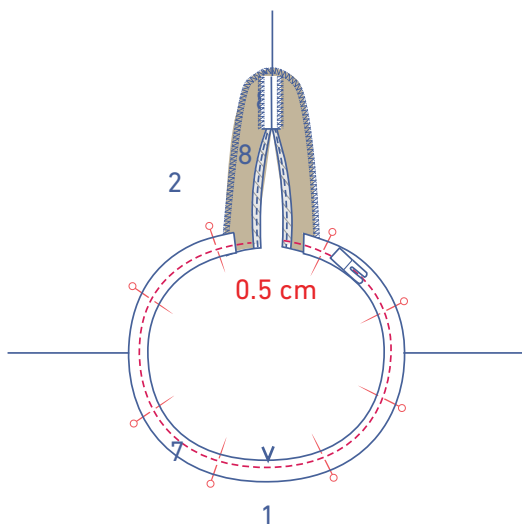

The ends of the bias tape should be on top of the folded facing and should stop just a little before the CB seam. Snip any excess length off. (Providing the exact length is tricky because the grain line is on the bias, i.e. it will differ according to fabric type.)

Sew into place at 0.5 cm.

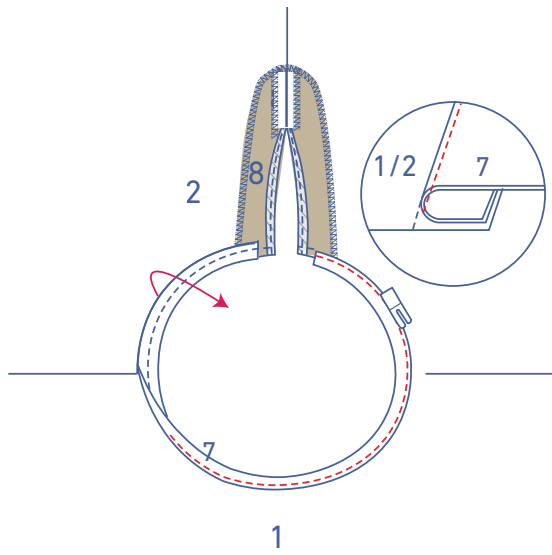

Fold the bias tape over and stitch the bias tape to the seam allowance underneath, right next to the seam.

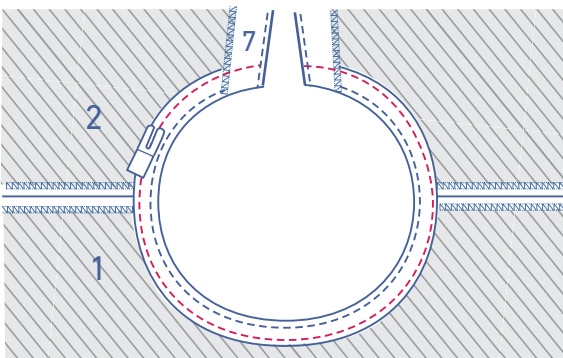

Fold the bias tape and the facing pieces all the way over to the wrong side and edgestitch into place.

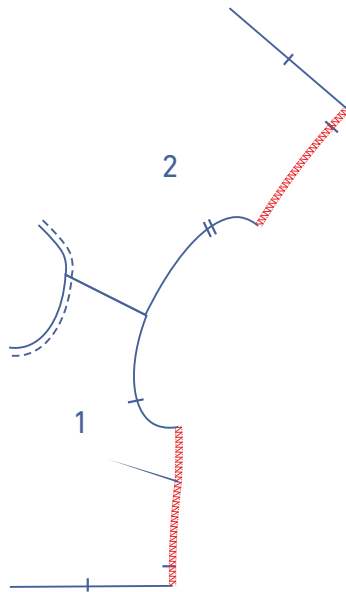

5

Finish the sides of the bodice with overlock stitching.

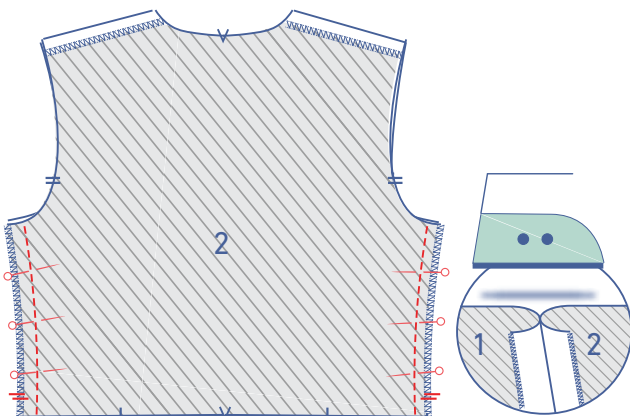

Pin and sew the side seams together. Press the seam allowance open.

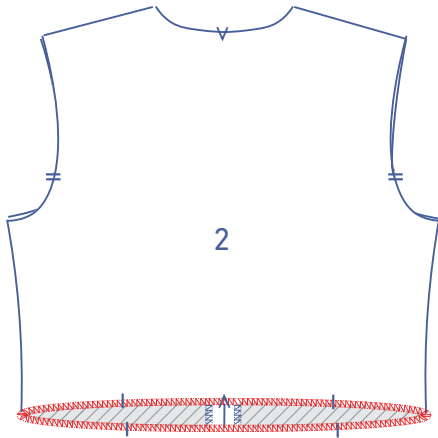

Finish the bottom of the bodice with overlock stitching.

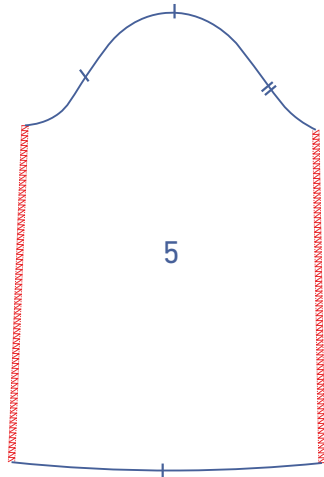

6

Finish the sleeve sides (5) with overlock stitching.

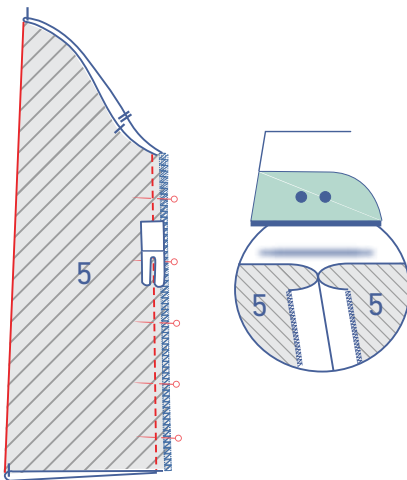

Pin and sew the underarm seam. Press the seam allowance open.

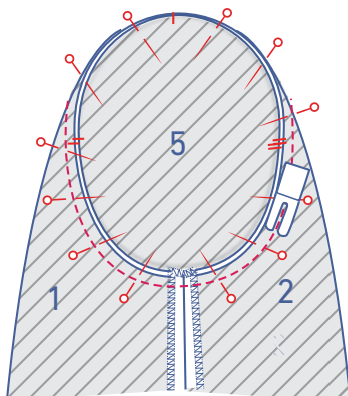

Pin and sew the top of the sleeve (= sleeve cap) to the armhole, matching the notches. The single notch marks the front, while the double notch marks the back. The single notch at the top should be even with the shoulder seam. Distribute the 'excess' fabric evenly between the other single notches.

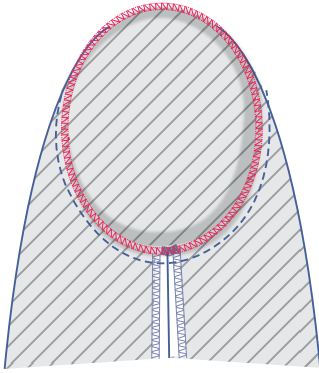

Finish the raw edges together with overlock stitching.

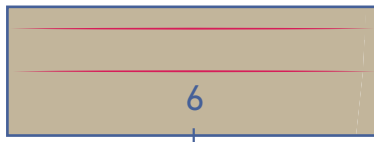
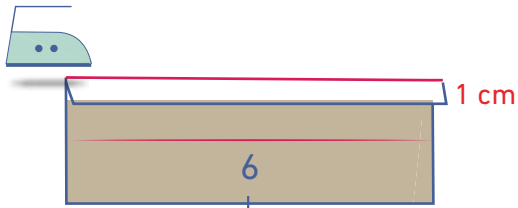
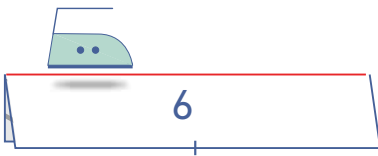

7

Press the cuff (6) in half with the long ends touching and the wrong sides of the fabric facing to create a fold line. Open back out.

Press the unnotched long end towards the wrong side by 1cm to create a fold line. Open back out.

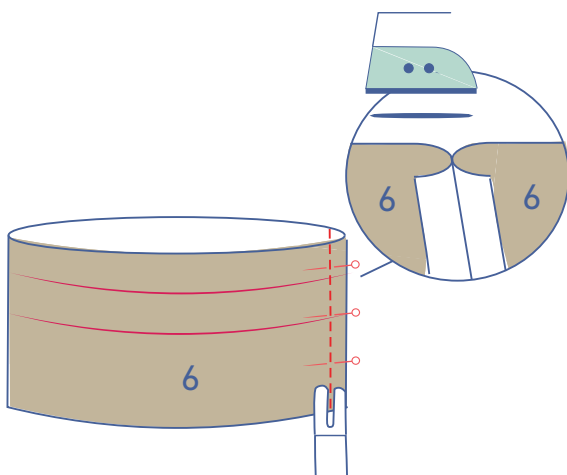

Fold the cuff in half with the short ends together and the right sides of the fabric facing. Pin and sew the short ends together. Press the seam allowance open.

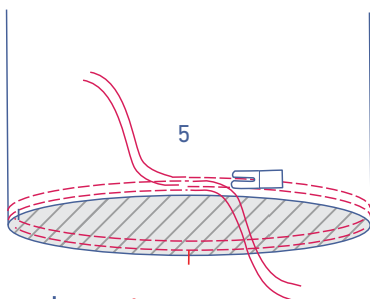

Stitch two parallel rows along the bottom of the sleeve, using a long stitch at a low thread tension. Leave a length of thread at the start and end of the rows.

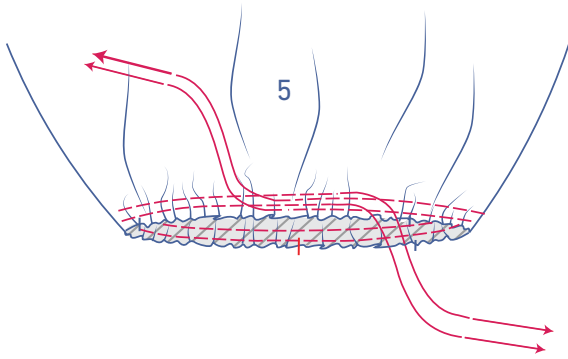

Carefully tug the ends of the threads to gather the fabric.

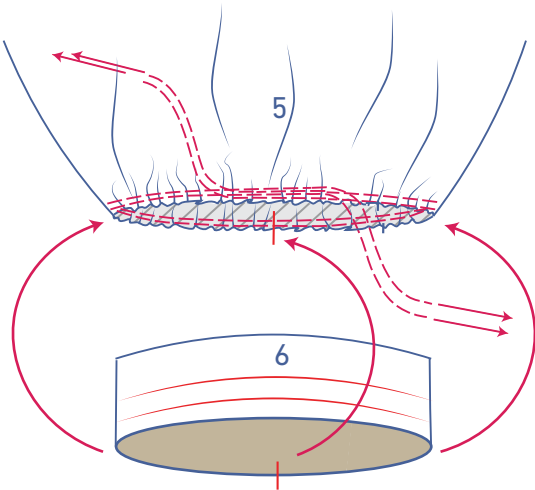

Distribute the gathers until the notches and seams of the sleeve and cuff match.

Slide the sleeve over the cuff and pin the unpressed raw edge of the cuff to the bottom of the sleeve along the inside (= the wrong side).

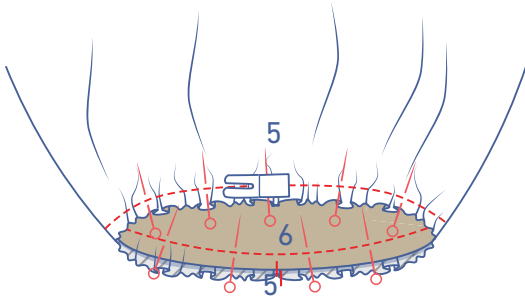

Stitch into place.

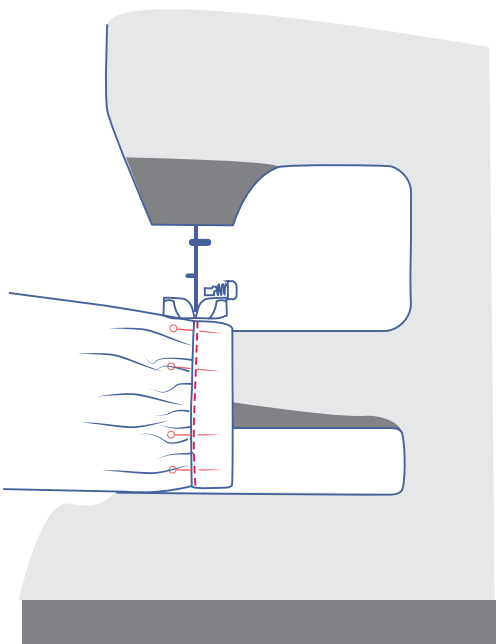

Open the cuff out so that it's on the right side of the sleeve. Place the fold line directly over the stitching. Edgestitch into place.

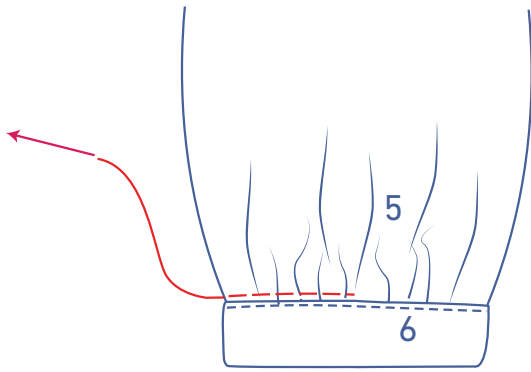

Remove the gathering threads.

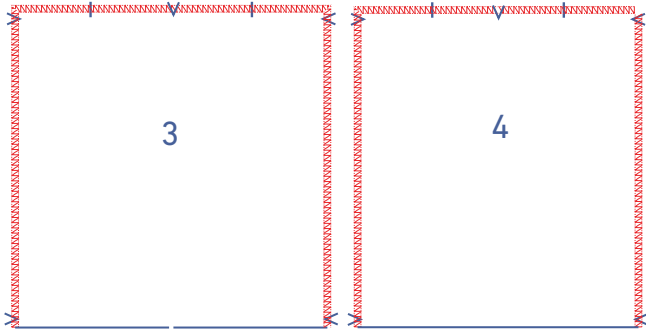

8

Finish the indicated edges of the skirt front (3) and skirt back (4) with overlocking.

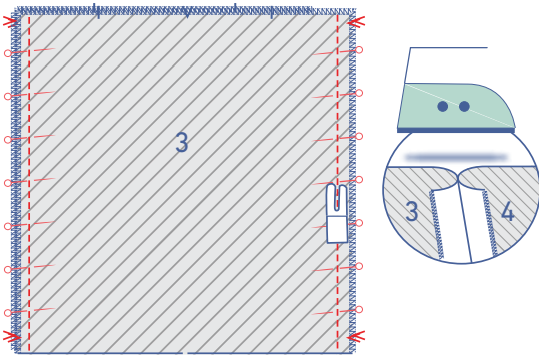

Pin and sew the side seams together. Press the seam allowance open.

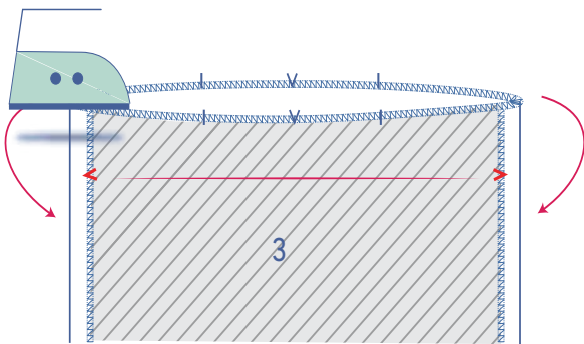

Press the top of the skirt over at the V notches.

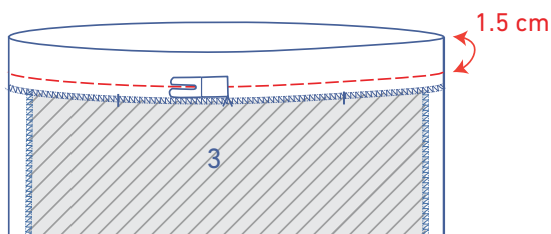
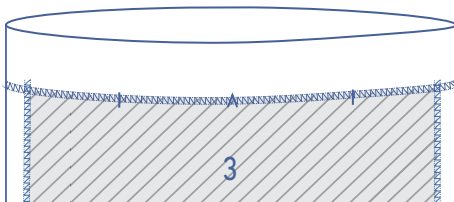

Sew a line of tacking at 1.5 cm from the skirt's fold line using a long stitch at a low thread tension. This is to hold the fold into place.

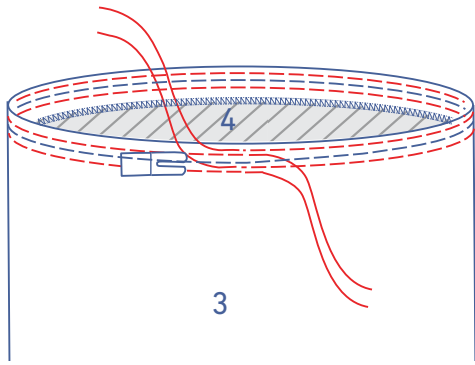

Now, sew two parallel lines on either side of this tacking using a long stitch length at a low thread tension. Leave a length of thread at the start and end of the stitching.

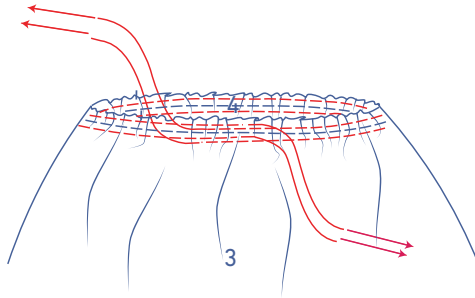

Carefully tug the ends of the threads to gather the fabric.

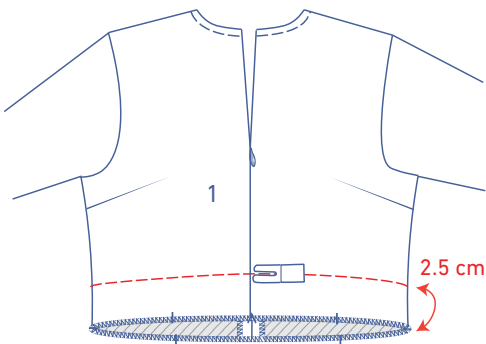

Sew a line of tacking at 2.5 cm from the raw edge of the bodice using a long stitch at a low thread tension.

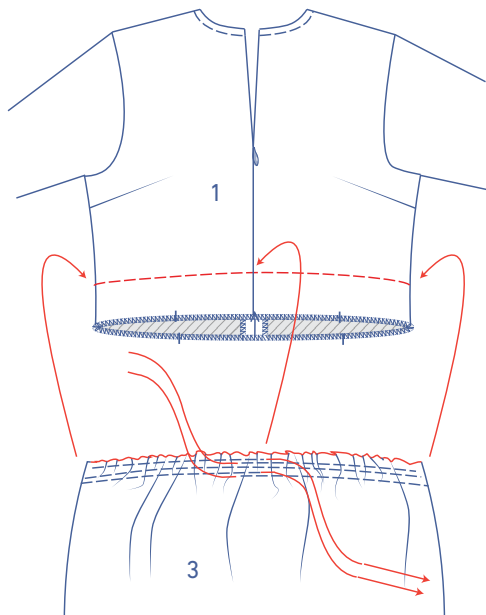

Slide the bodice into the skirt. Distribute the gathers on the skirt evenly, matching the notches of the skirt and bodice.

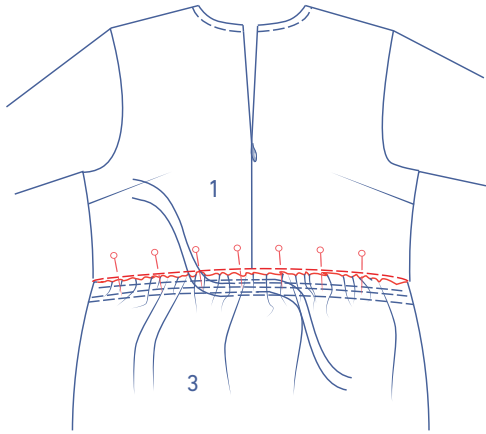

Pin the skirt to the bodice with the skirt fold line matching the bodice tacking.

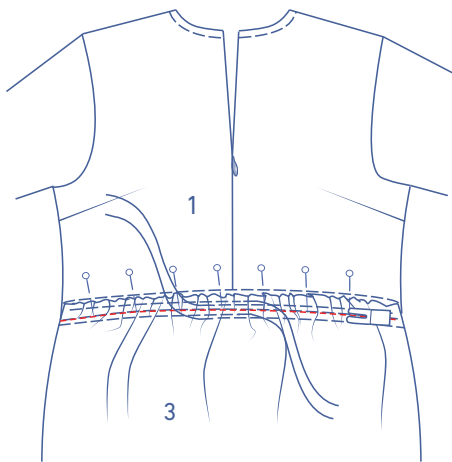

Sew the skirt to the bodice where you placed the line of tacking on the skirt.

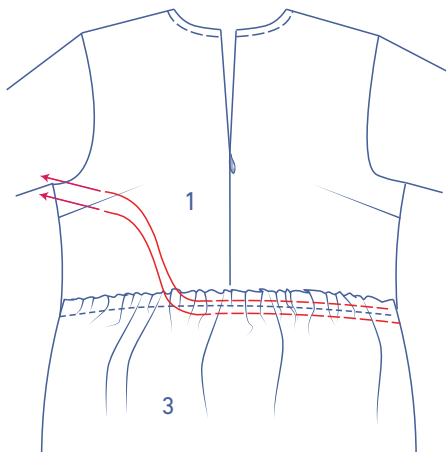
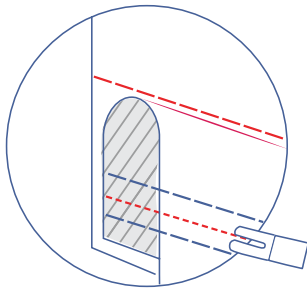

Then remove the tacking and gathering threads.

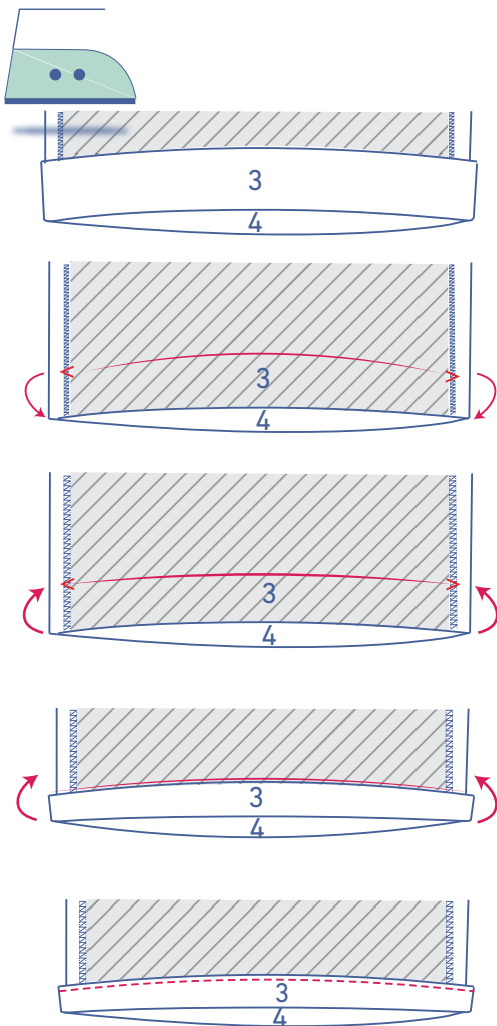

9

Press the hem allowance up at the V notches and then open back out.

Fold the raw edge down to meet the pressed fold line and then fold again.

Edgestitch into place.

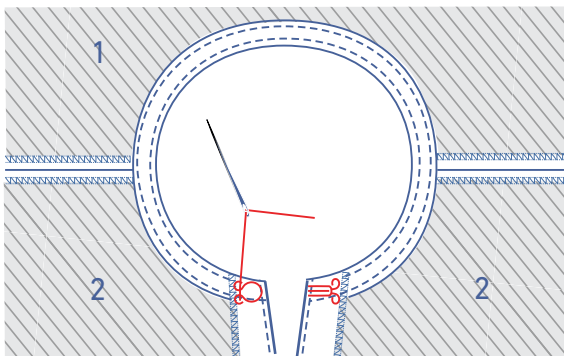

10

Sew the hook and eye on by hand at the CB for the version without a CF zip.