

Madou by Fibre ⚡ood



Madou by Fibre ood

***✂✂



XS - XXXL

Line dancing, anyone? Or stories by the campfire? Country vibes, lumberjack, trucker – it makes no difference. Madou is always you. This overshirt is for making and wearing without much ado. Denim, checked flannel, plain, sturdy linen – it's all good. Just take your pick. The same goes for the length. The long, narrow chest pockets are shoo-in crowd-pleasers and the two rows of topstitching throughout are a must.

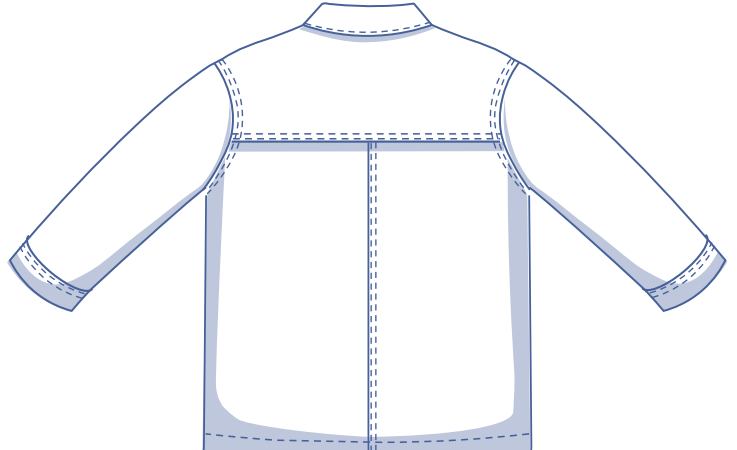
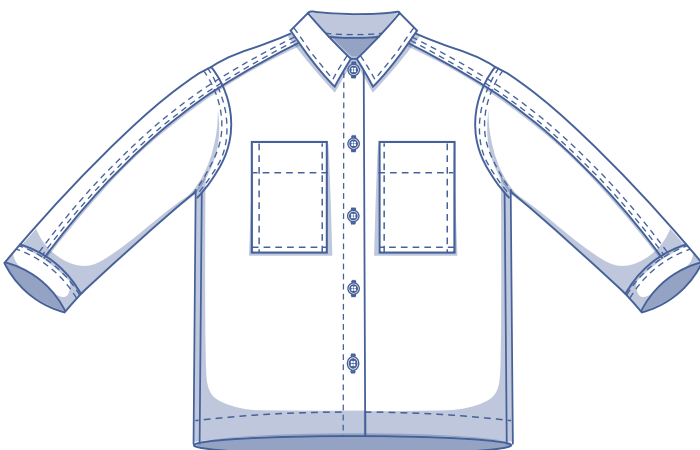
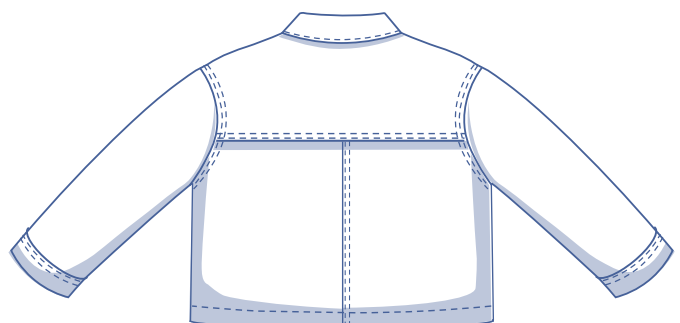

size chart (in cm)

size	XS		S		M		L		XL		XXL		XXXL		
	4	6	8	10	12	14	16	18	20	22	24	26	28	30	32
body height	160	164	166	167	168	169	170	171	172	172	172	172	172	172	172
B (bust)	76	80	84	88	92	96	100	104	110	116	122	128	134	140	146
H (hips)	86	90	94	97	100	103	106	109	115	120	125	130	135	140	145

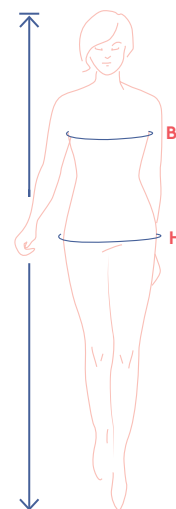

Choose your size based on your **bust measurement**. Is your hip measurement wider than what's listed in the size chart? If so, check the hip measurement in the size chart below to check whether there is enough room or whether the pattern needs to be altered. It is easy to do. When tracing the pattern, simply trace from the line of one size to the line of the other.

pattern measurements (in cm)

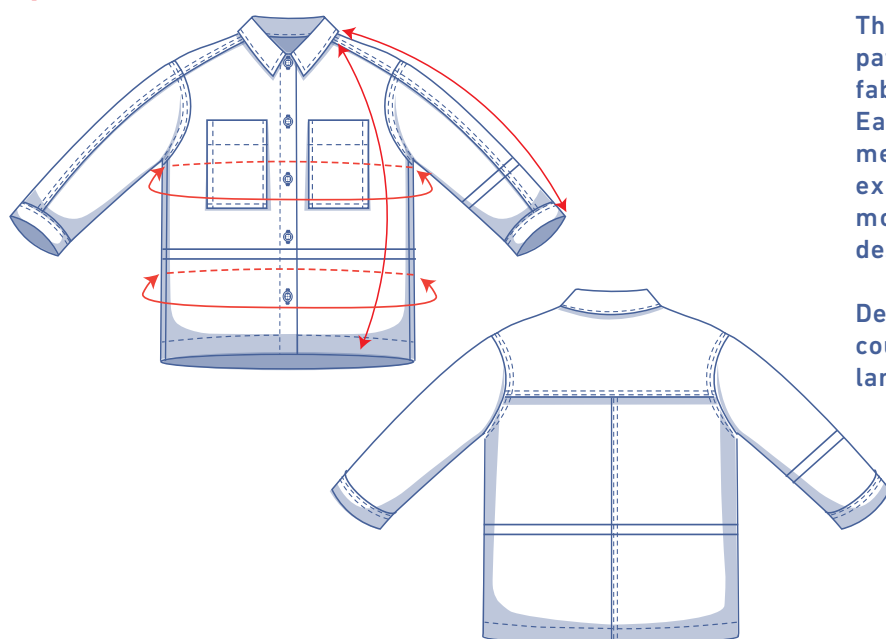

This chart's measurements are the pattern measurements based on the fabric type and serve as a reference. Ease has been added to the width measurements (in addition to the exact body measurements) for a more comfortable fit. Madou is designed to have a **loose cut**.

Depending on the preferred cut, you could decide to go a size smaller or larger than the recommended size.

== shorten or lengthen the pattern here

size	XS	S	M	L	XL	XXL	XXXL
length long version	71.25	73	74.75	76.5	78.75	81.25	83.5
length short version*	48.25	50	51.75	53.5	55.75	58.25	60.5
sleeve length**	68.75	70.25	72	73.5	75.25	77	78.5
bust	107.5	115.5	123.5	131.5	141.5	153.5	165.5
hips	107.5	115.5	123.5	131.5	141.5	153.5	165.5

* Shorten pattern pieces 1 and 2 to this length to make a short version.

** Including the shoulder length and cuff.

Compare the stated lengths to the measured or desired lengths. **Lengthen** or **shorten** the jacket and/or sleeves by cutting the pattern pieces at the indicated double lines. Then either increase the distance between the cut pieces by the desired amount (to lengthen) or overlap the pieces (to shorten). Make sure that the CF and CB lines and the side seams are always straight.



IMPORTANT

Adjust the amount of fabric to be used based on these alterations.

notions



- Thread
- Iron-on interfacing: max. 75 cm
- Buttons (Ø 2 cm): see table
- Fabric: see table

buttons	XS	S	M	L	XL	XXL	XXXL
long version	5	5	6	6	6	6	6
short version	4	4	4	4	5	5	5

fabric long version		XS	S	M	L	XL	XXL	XXXL
fabric width 110 cm	cm	205	210	220	270	280	285	290
fabric width 140 cm	cm	165	165	175	210	215	215	220

The corresponding fabric layout can be found on page 6 of these sewing instructions.

fabric short version		XS	S	M	L	XL	XXL	XXXL
fabric width 110 cm	cm	155	160	205	210	215	220	235
fabric width 140 cm	cm	130	135	140	165	165	170	175

fabric advice



Madou looks divine in loads of different fabrics. Prefer a jacket with good structure? Go for cotton twill, denim, or stretch cotton. Looking for a design with a more fluid drape that has a softer look? Try linen, Tencel or gabardine.

Proud to be #Sewista

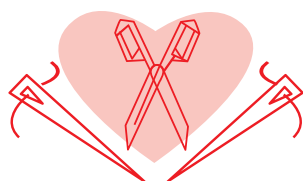

pattern pieces & seam allowances (in cm)

To sew the garment as described in the instructions, draw the illustrated seam allowances around the paper pattern pieces before cutting them out. If you are using a PDF pattern, the pattern can be printed with or without seam allowance.

To find out more, watch the [video](#).

1. front: 2x
2. back: 2x
3. yoke: 1x on fabric fold
4. sleeve front: 2x
5. sleeve back: 2x
6. collar: 2x on fabric fold
7. cuff: 2x
8. chest pocket: 2x
9. pocket: 4x

IMPORTANT

The pieces highlighted in light yellow have iron-on interfacing attached to the wrong side.

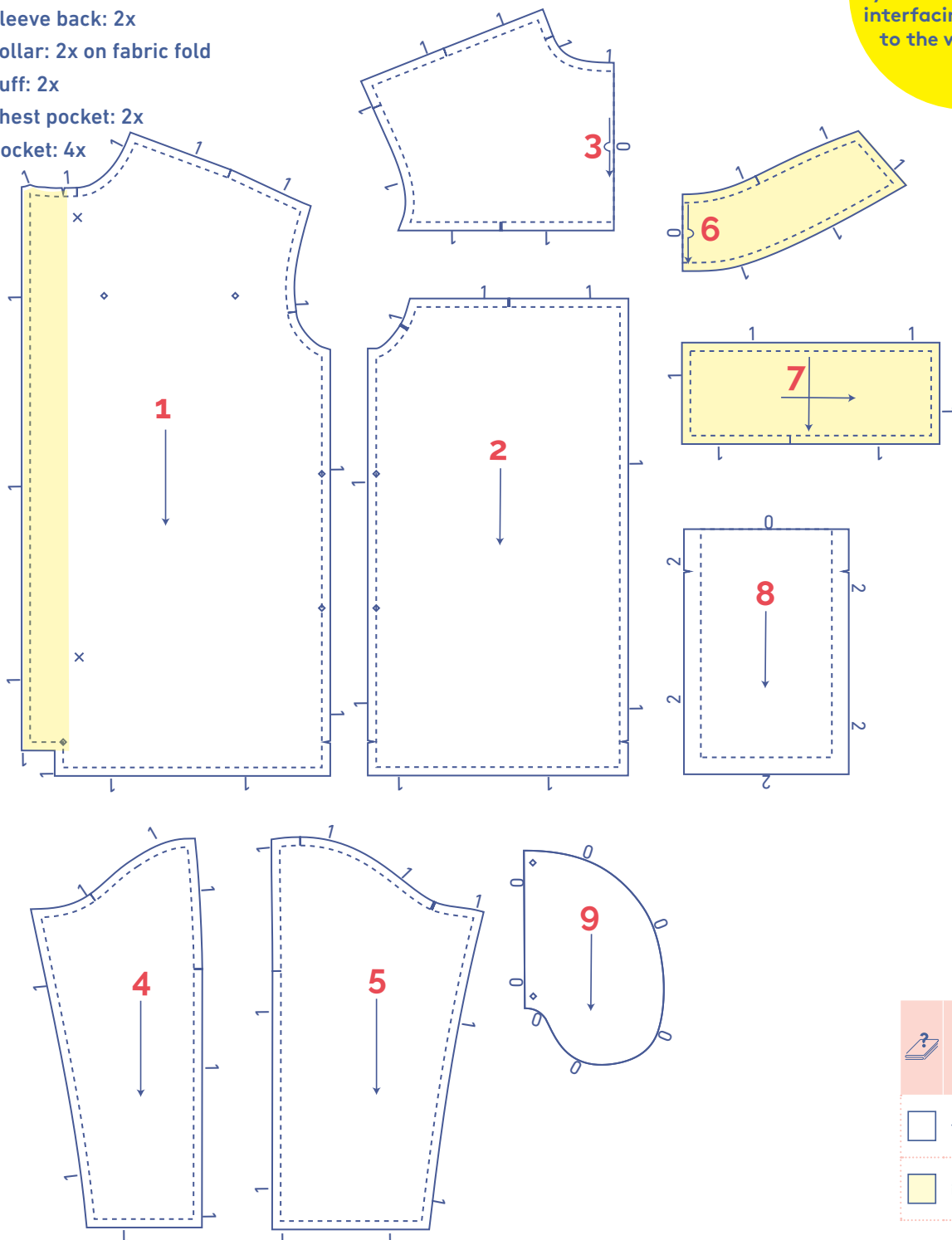

TIP

To make the short version, shorten pattern pieces 1 and 2 by cutting them at the double lines (as illustrated under 'pattern measurements' on page 3 of these sewing instructions) and overlapping the pattern pieces until you achieve the desired length. Our suggested length as stated in the 'pattern measurements table' has been measured from the notch in the neckline of pattern piece 3 to the finished hem.

fabric layout – solid fabrics
fabric width 110 cm

XS - M

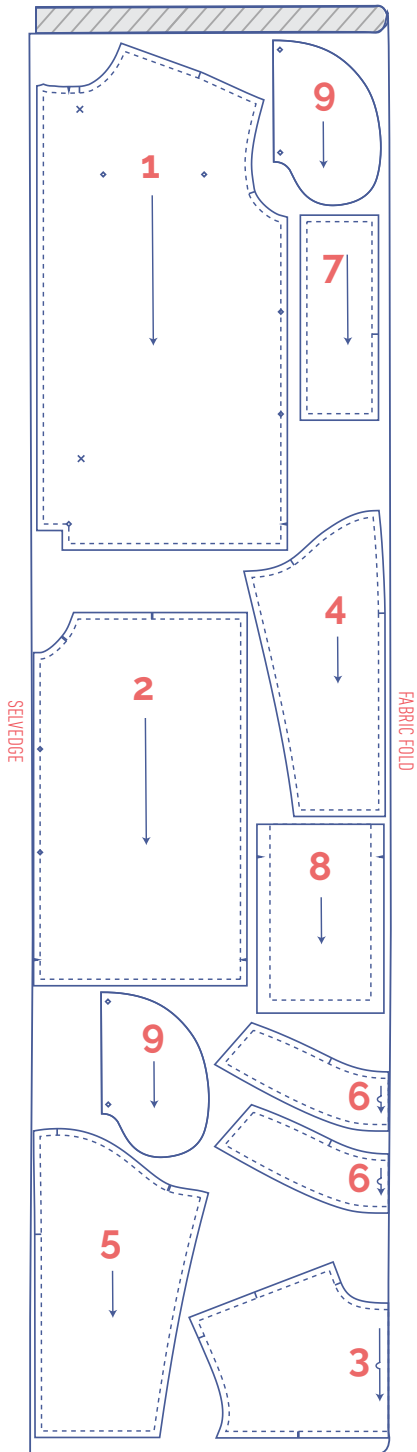

L - XXXL

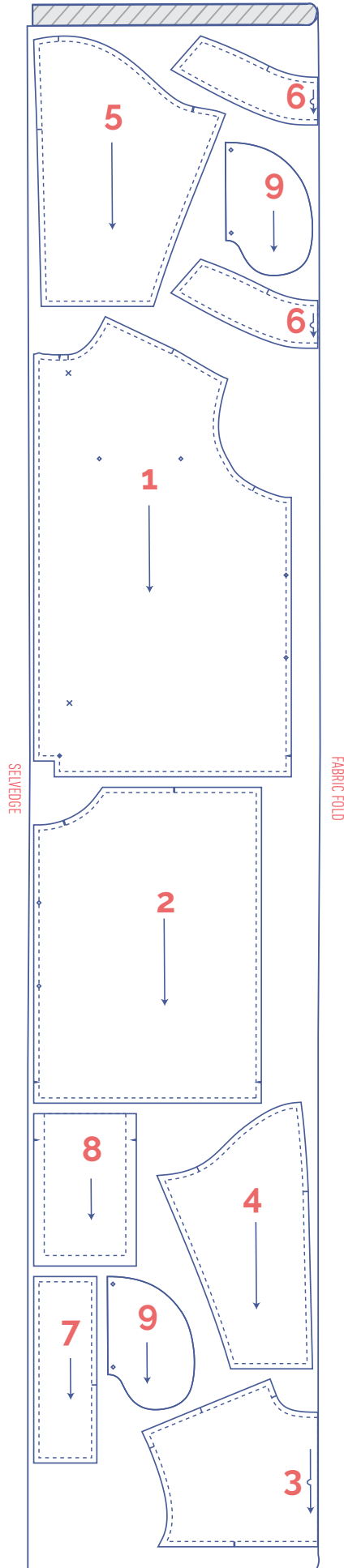

fabric layout – solid fabrics

fabric width 140 cm

XS - M

L - XXXL

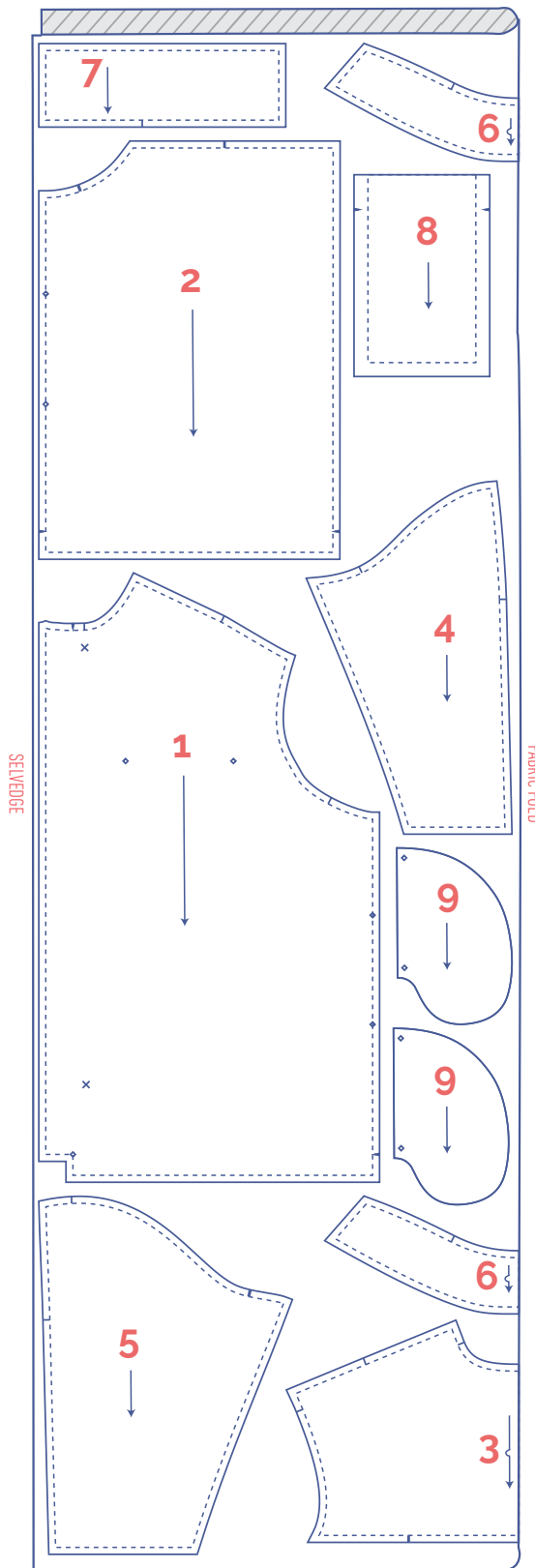
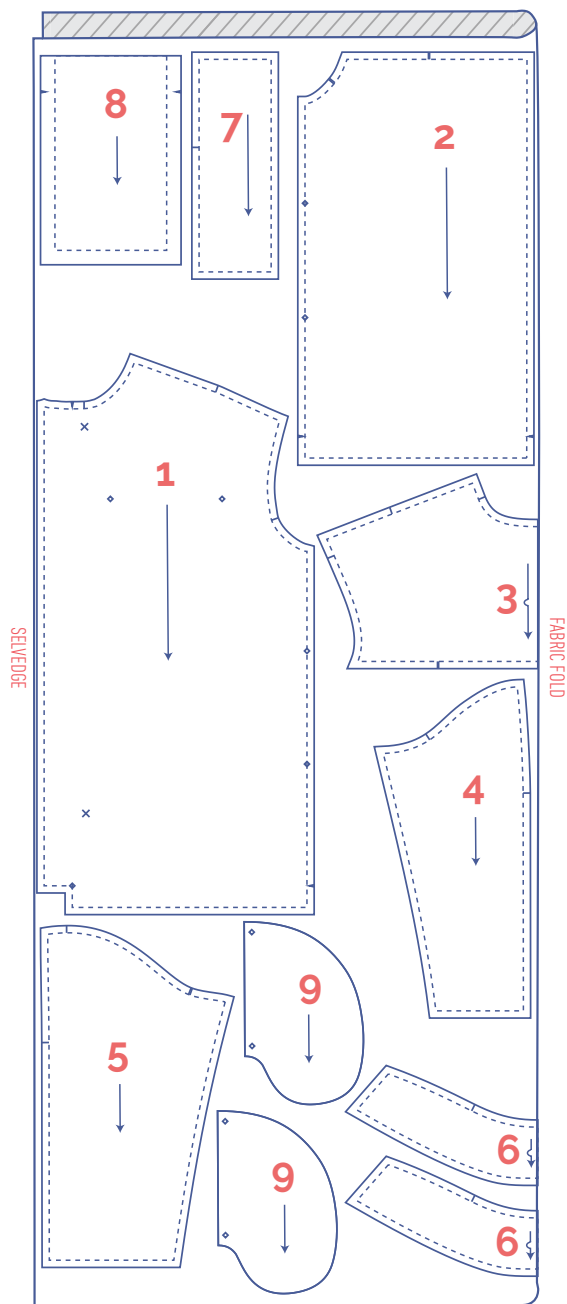

marking pattern pieces



Notch the pattern paper and fabric at the following points

| single notch

|| double notch

V V notch



Mark the following points with marking thread



centre point



snap/button

sewing instructions



The method used to finish the seams depends on the fabric used. The pieces are always sewn together with the right sides of the fabric facing, unless stated otherwise.

F front

B back

CF centre front

CB centre back

RF right front



LF left front



RB right back



LB left back



right side



wrong side



iron-on interfacing

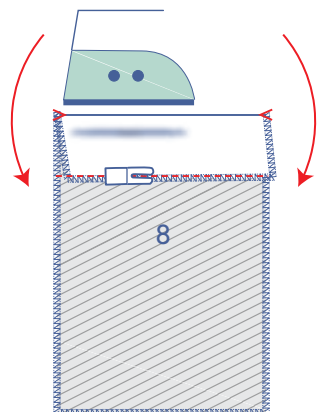
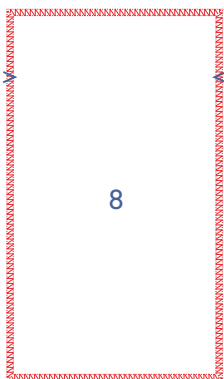
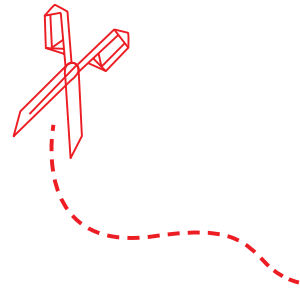

1

Finish the edges of the chest pocket (8) where indicated with overlock stitching.

Press the top over at the V notches. Sew into place.

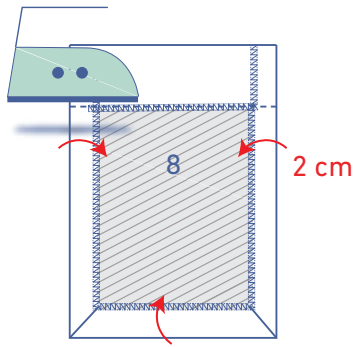

Press the remaining pocket ends 2 cm towards the wrong side.

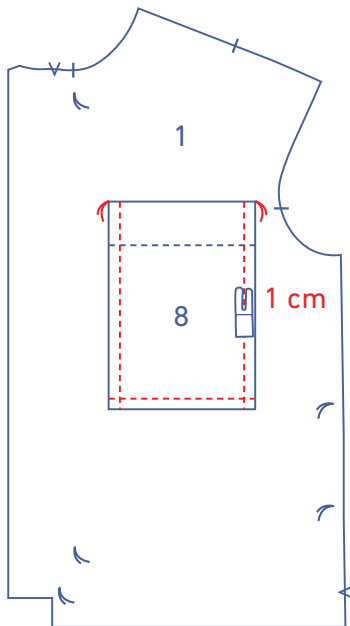

Pin the pocket to the front (1) where indicated. Sew into place at 1 cm from the edge as illustrated.

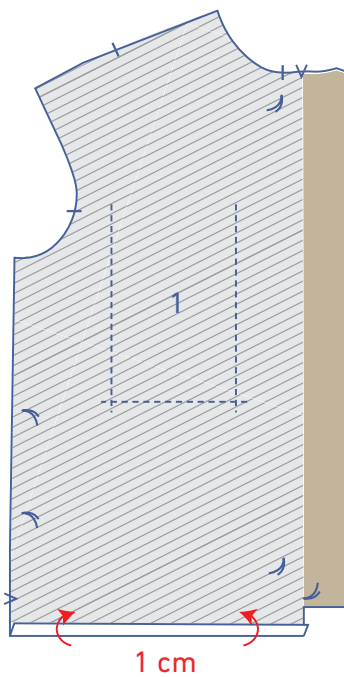

2

Press the fold lines for the hem of the front; start by pressing 1 cm towards the wrong side.

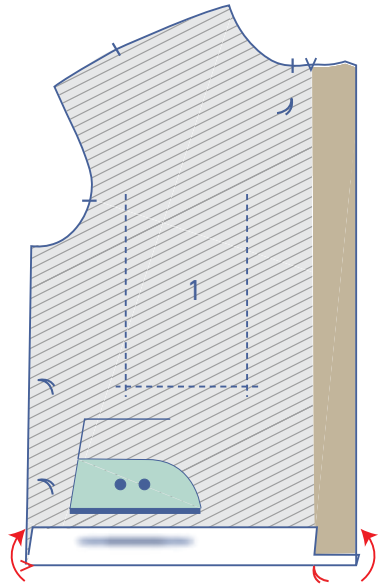

Then, fold over at the indicated V notch and marking thread and press again.

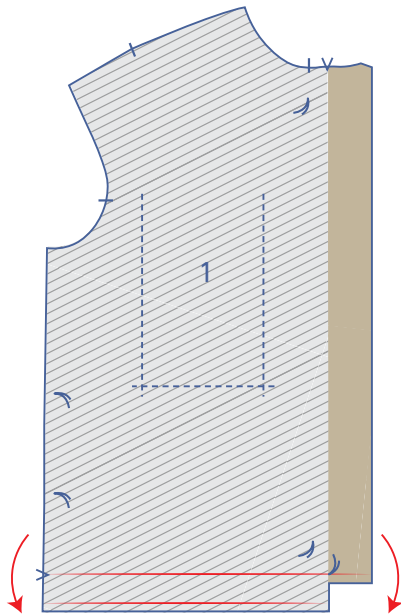

Now, open back out.

3

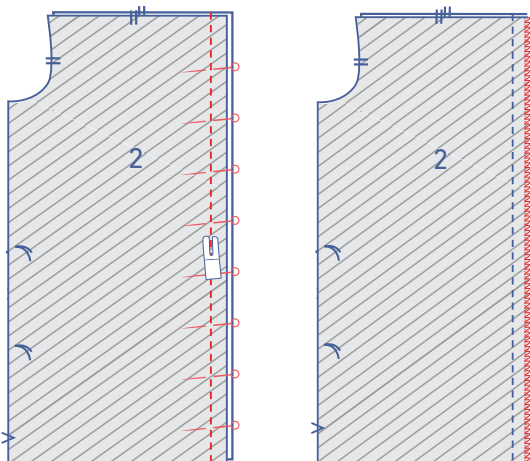

Pin and sew both back pieces (2) together. Finish the CB seam with overlock stitching.

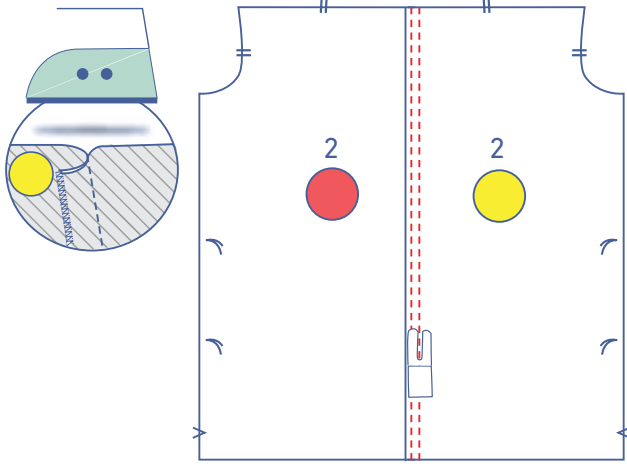

Press the seam allowance towards the RB. Now, sew the RB with two parallel lines of topstitching, right next to the seam.

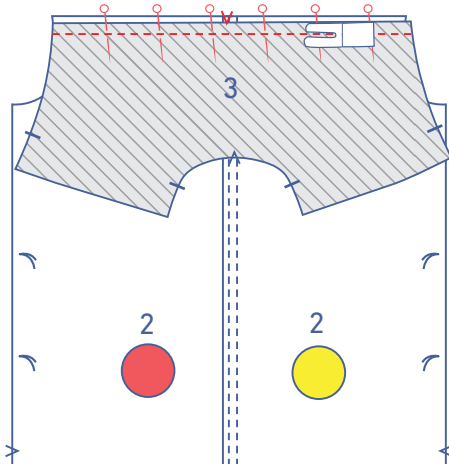

Pin and sew the yoke (3) to both back pieces. The V notch marking the centre of the yoke should evenly line up with the CB seam.

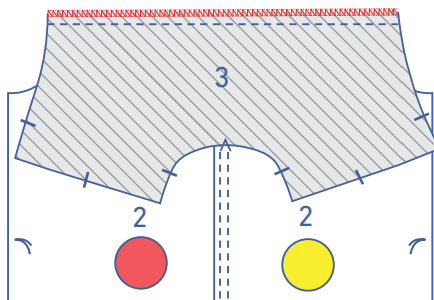

Finish the raw edges with overlock stitching.

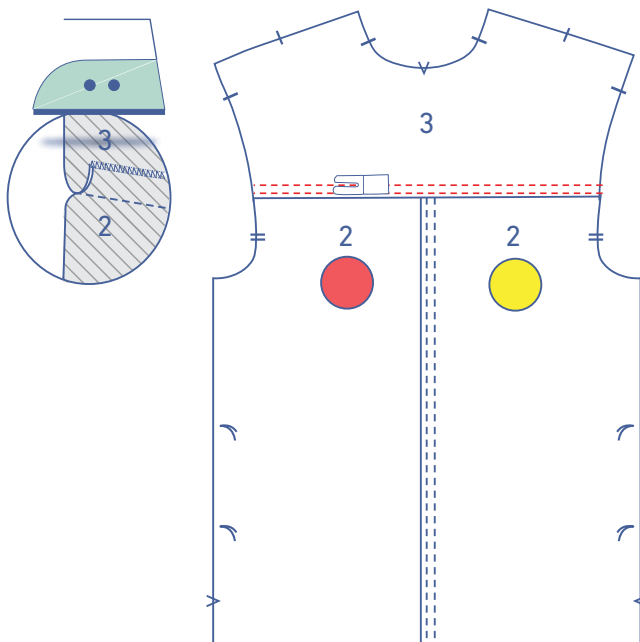

Press the seam allowance towards the yoke. Now, sew the yoke with two parallel lines of topstitching, right next to the seam.

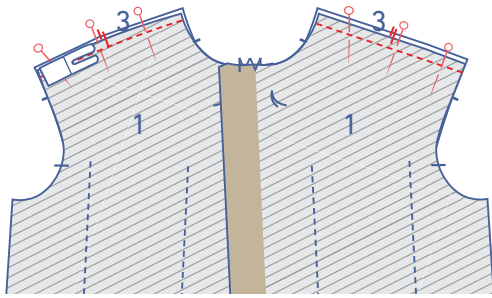

4

Pin and sew the front to the yoke (3), matching the notches.

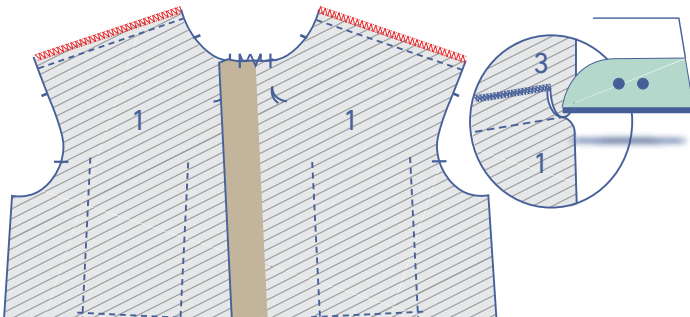

Finish the raw edges and press the seam allowance towards the yoke.

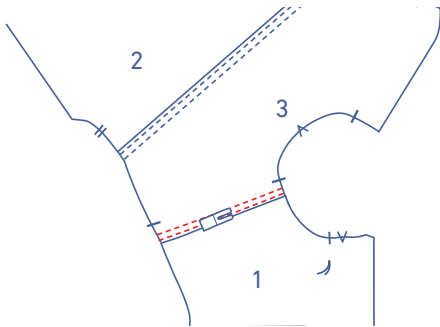

Now, sew the yoke with two parallel lines of topstitching, right next to the seam.

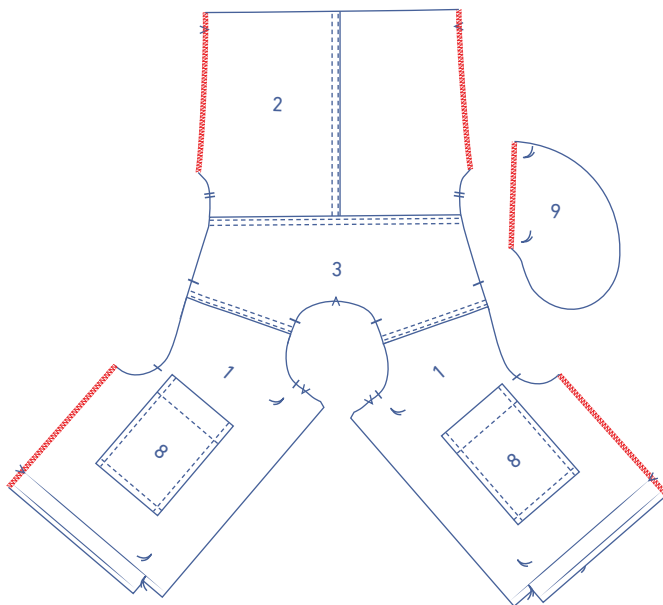

Finish the indicated raw edges of the bodice and the straight ends of all pocket pieces (9) with overlock stitching.

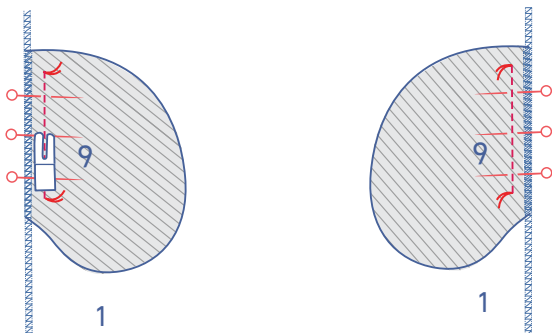

Pin the straight ends of two of the four pocket pieces to each side of the front, matching the marking threads. Sew into place between the marking threads.

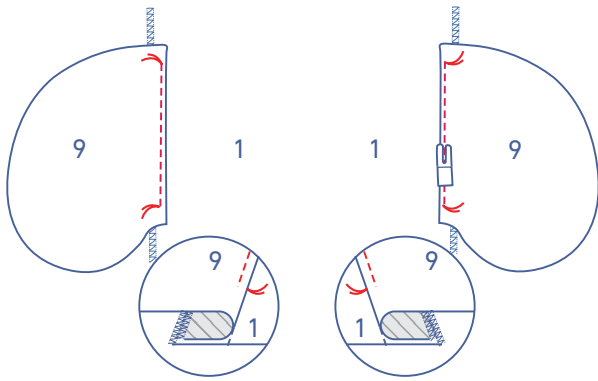

Fold the pocket and seam allowance over and sew the pocket to the seam allowance underneath.

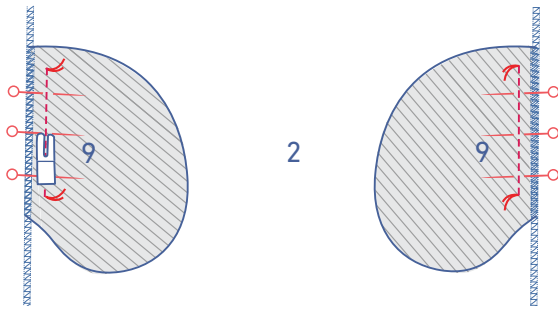

Pin the straight ends of the remaining pocket pieces to the sides of the back, matching the marking threads. Sew into place between the marking threads.

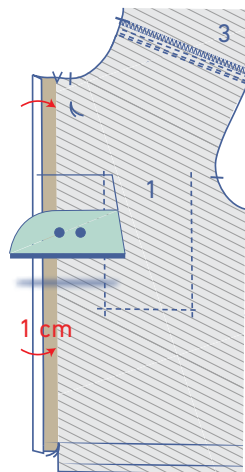

5

Press 1 cm of the facing at the CF towards the wrong side.

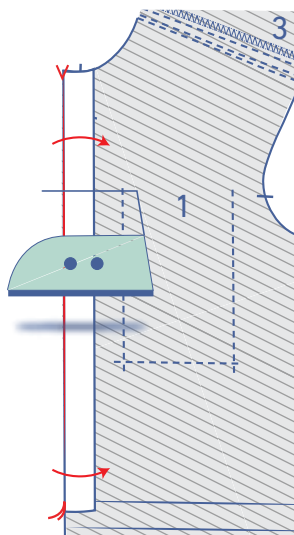

Press the facing towards the wrong side at the top V notch and bottom marking thread to create a fold line.

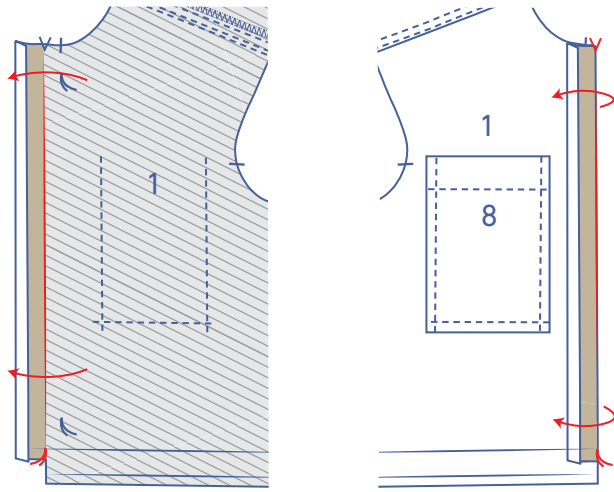

Now open back out and fold the facing towards the right side along the fold line at the V notch.

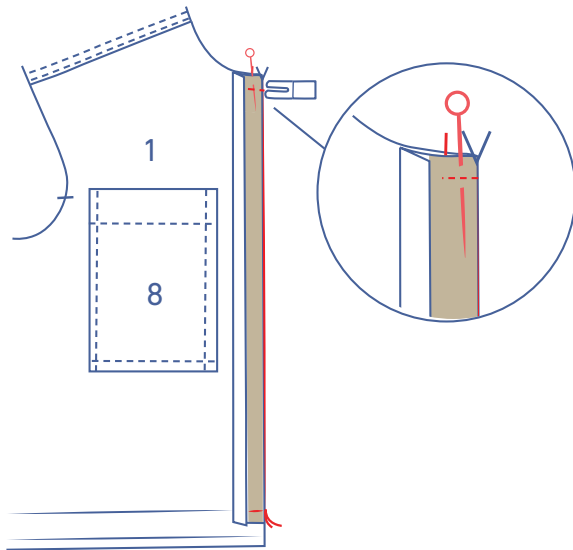

Pin the facing into place at the top and sew up to the notch marking the CF.

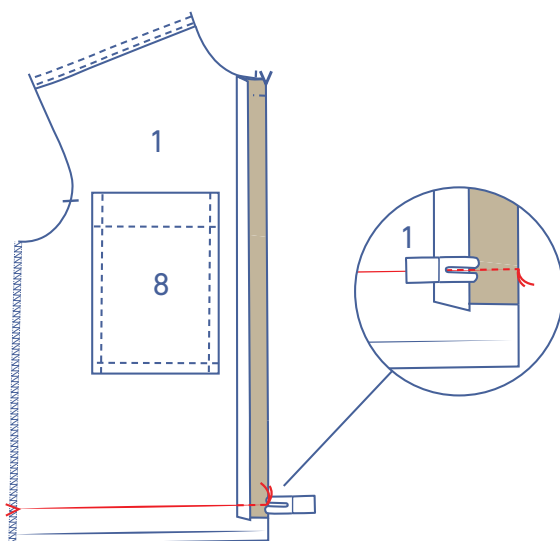

Pin the facing at the bottom, sew into place along the horizontal fold line you made earlier.

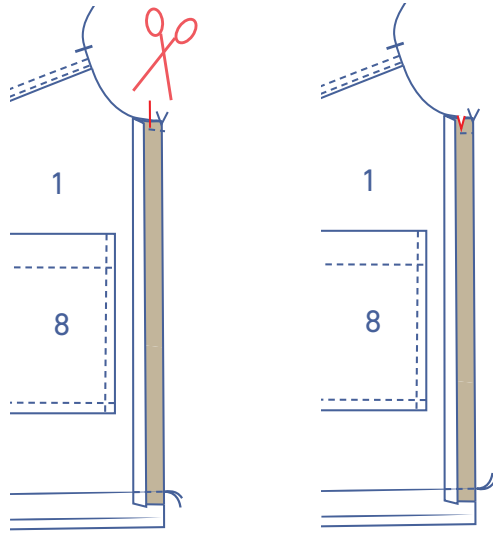

Snip into the seam allowance of the front at the notch marking the CF, stopping just before the stitching.

Turn the facing the right way out.

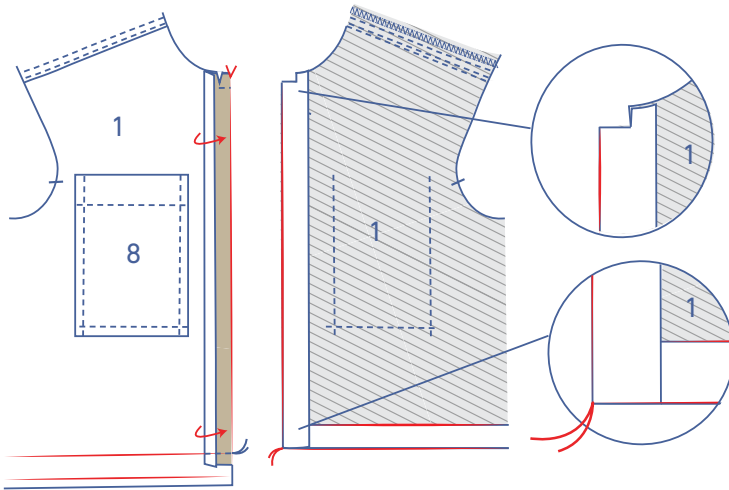

Sew the facing into place right next to the edge.

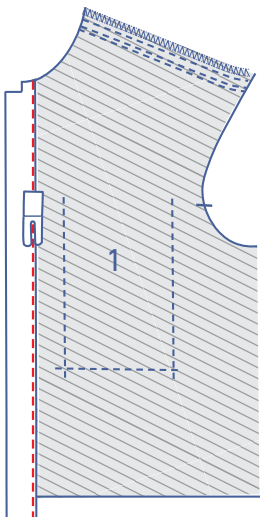

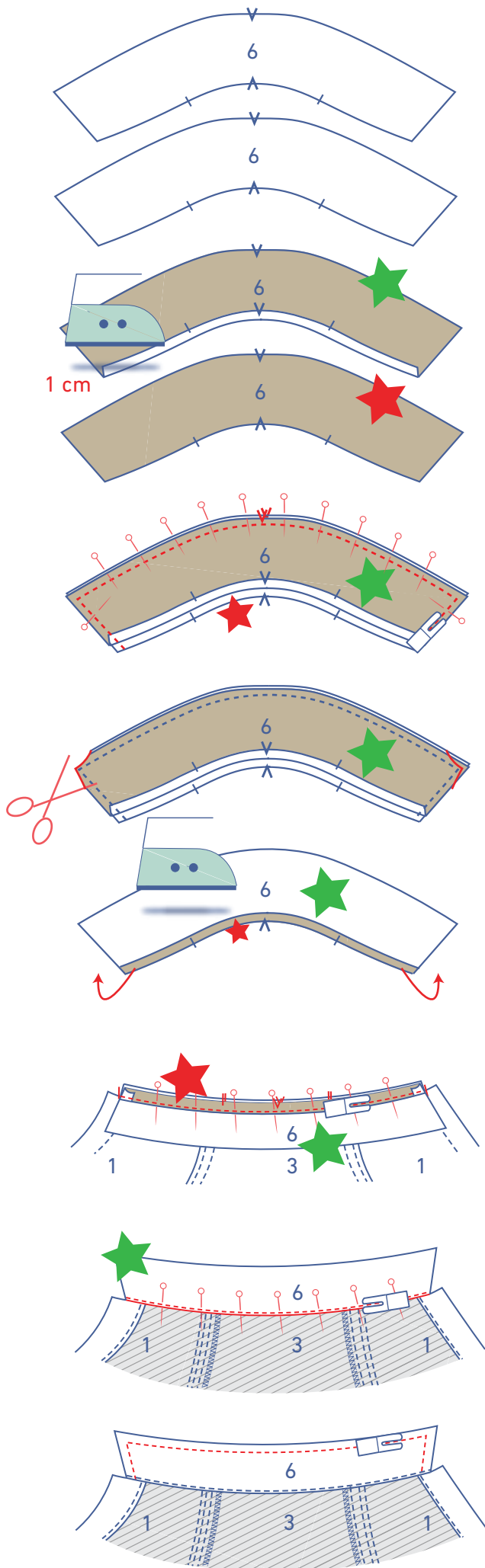

6

Press the seam allowance at the bottom of one of the collars (6) 1 cm towards the wrong side.

This collar has been marked with a green star.

Place the green star collar over the red star collar, right sides together. Pin and sew the contours of the collar together, leaving the bottom end open.

Trim the seam allowance at the corners.

Turn the collar the right way out.

Pin the red star collar to the neckline along the right side of the garment, matching the notches. The finished side of the collar aligns with the notch in the CF; there are V notches to mark the CB, and the notches on either side of the V notches align with the notch in the yoke (the true shoulder).

Fold the green star collar towards the wrong side of the garment and place the fold line (of the pressed seam allowance) directly over the previous stitching. Sew into place right next to the edge.

Topstitch all the way around at presser foot width from the edge.

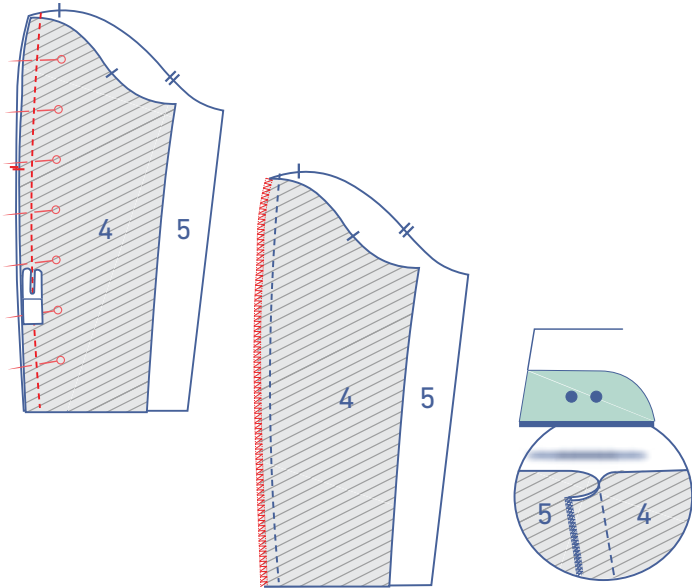

7

Pin and sew the sleeve front (4) and sleeve back (5) together, matching the markings.

Finish the raw edges with overlock stitching. Press the seam allowance towards the back sleeve piece.

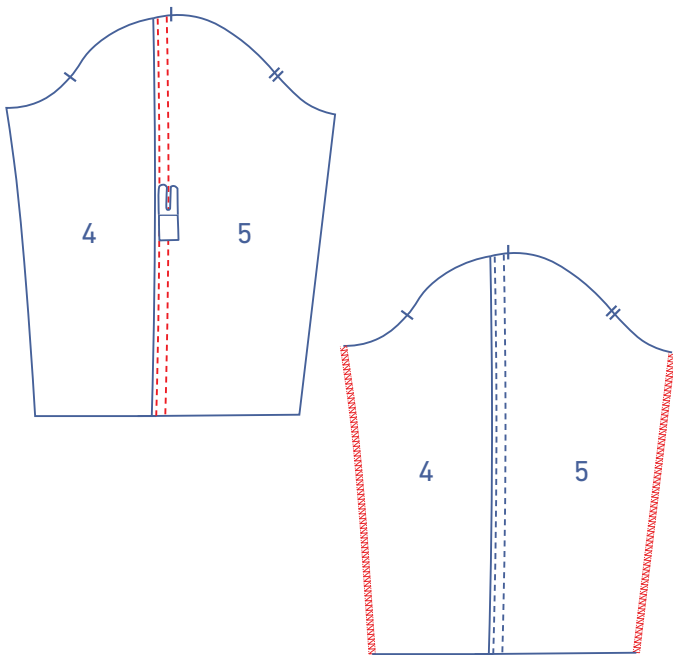

Sew the back sleeve piece with two parallel lines of topstitching right next to the seam.

Finish the sides of the sleeve with overlock stitching.

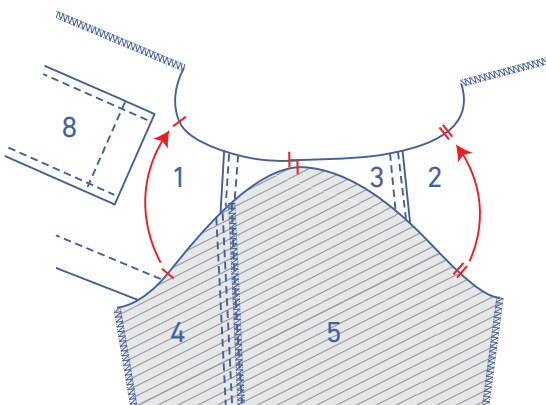

Pin and sew the sleeve cap to the armhole, matching the notches. The single notch in the sleeve should match the single notch in the front; the double notch in the sleeve should match the double notch in the back, and the top single notch in the sleeve aligns with the notch in the yoke marking the true shoulder.

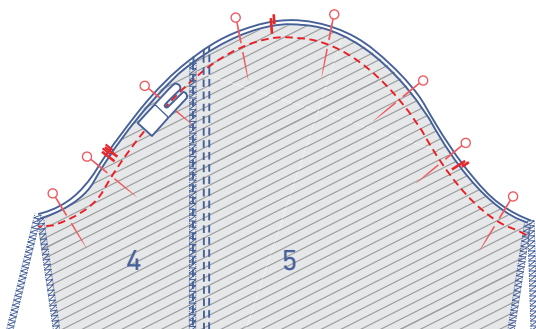

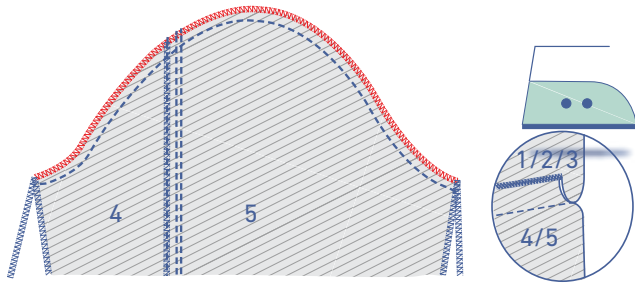

Finish the raw edges with overlock stitching.

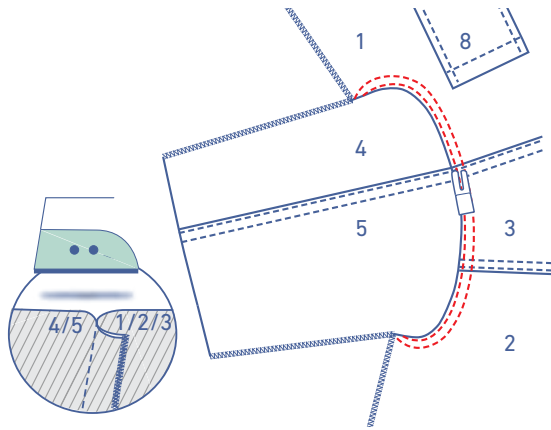

Press the seam allowance towards the bodice. Now, topstitch two parallel lines right next to the seam as shown.

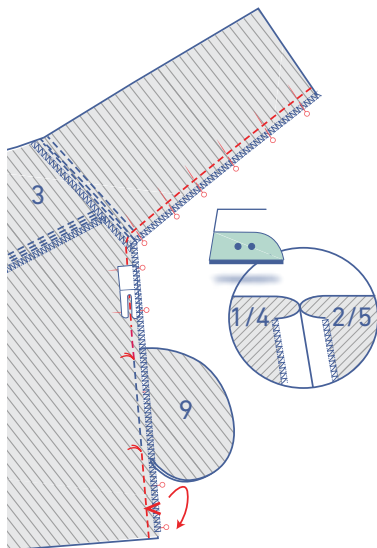

Fold the sleeve in half and match the front and back pieces with the right sides touching. Pin the underarm and side seams above and below the pocket opening and sew together. Press the seam allowance open.

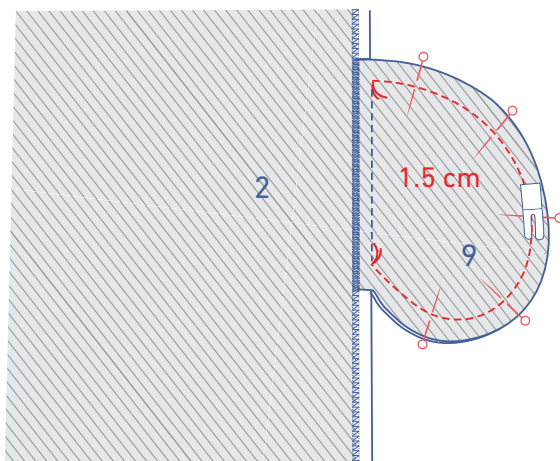

Pin and sew the contours of the pockets together at 1.5 cm.

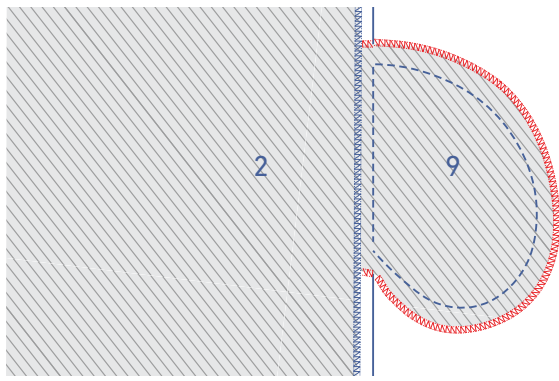

Finish the raw edges of the pocket with overlock stitching.



8

Press the cuff (7) in half with the long ends together to create a fold line.

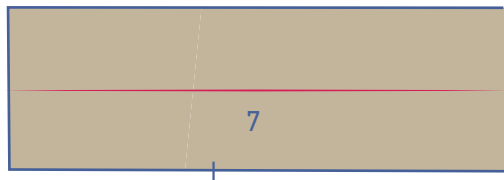

Then open back out.

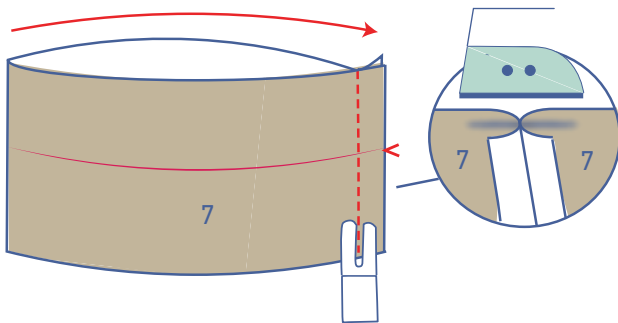

Now, fold the cuff in half so that the short ends are touching and the right sides of the fabric are facing each other. Pin and sew the underarm seams together and press the seam allowance open.

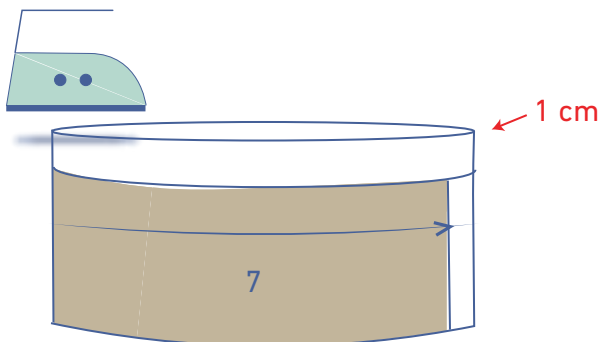

Press the unnotched long end 1 cm towards the wrong side.

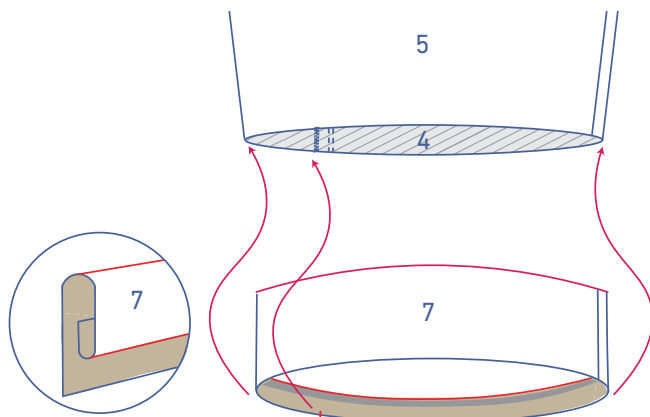

Slide the bottom of the sleeve over the cuff, pinning the unpressed raw edge of the cuff to the bottom of the sleeve. The notch in the cuff should match the seam of the sleeve.

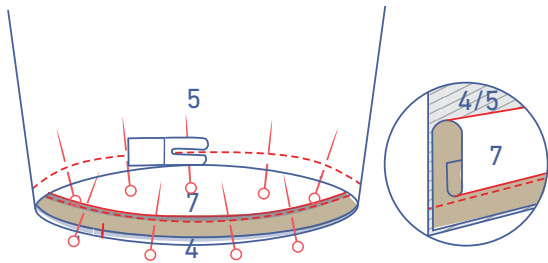

Sew into place.

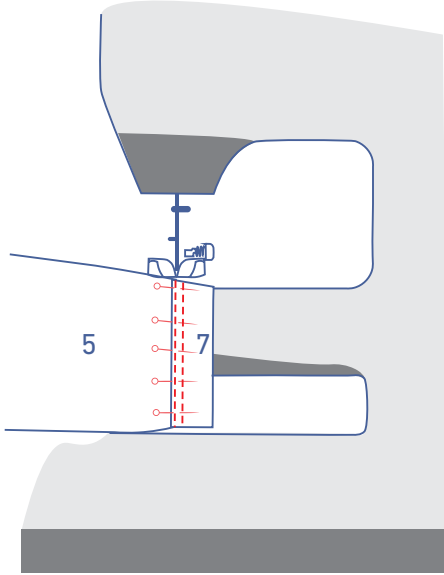

Open the cuff out to the right side of the sleeve and place the fold line (of the pressed seam allowance) directly over the previous stitching. Sew into place right next to the edge with two lines of parallel topstitching.

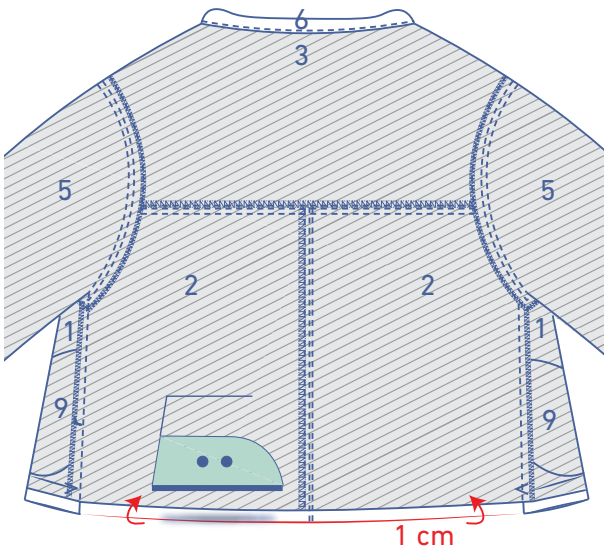

9

Press the hem allowance of the back 1 cm towards the wrong side.

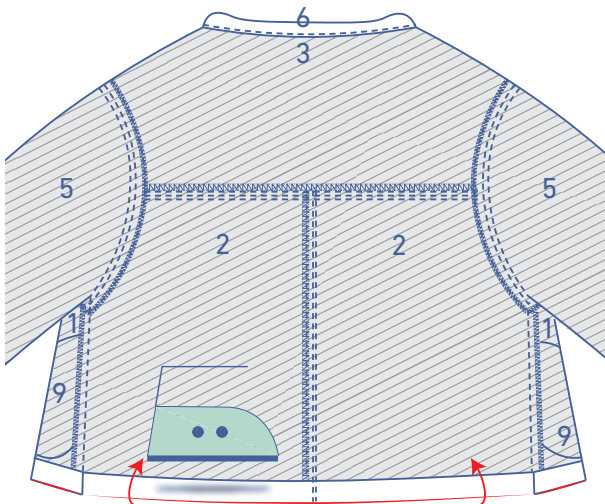

Then, fold over at the V notches and press again.

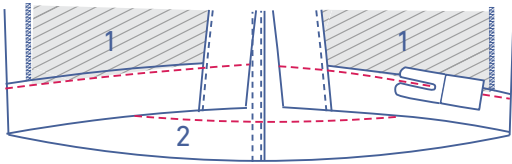

Sew the hem allowance into place all the way around, right next to the edge.

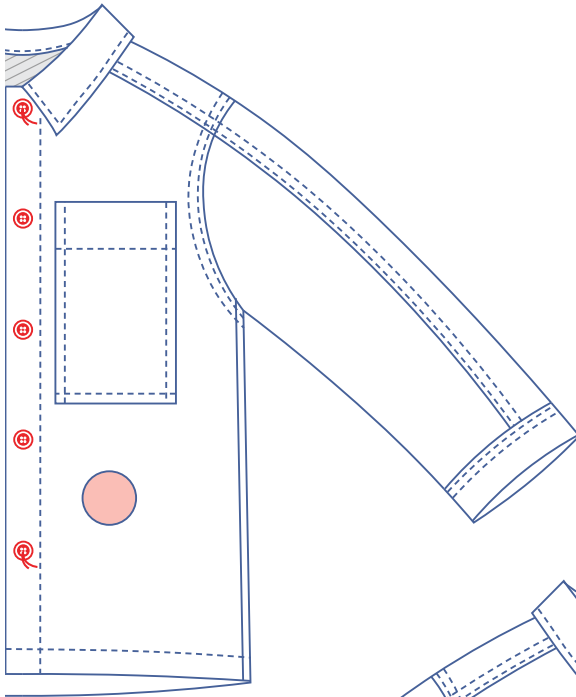

10

Sew the buttons onto the LF. The top and bottom buttons have been marked on the pattern. Divide the distance between them evenly to determine the location of the other buttons.

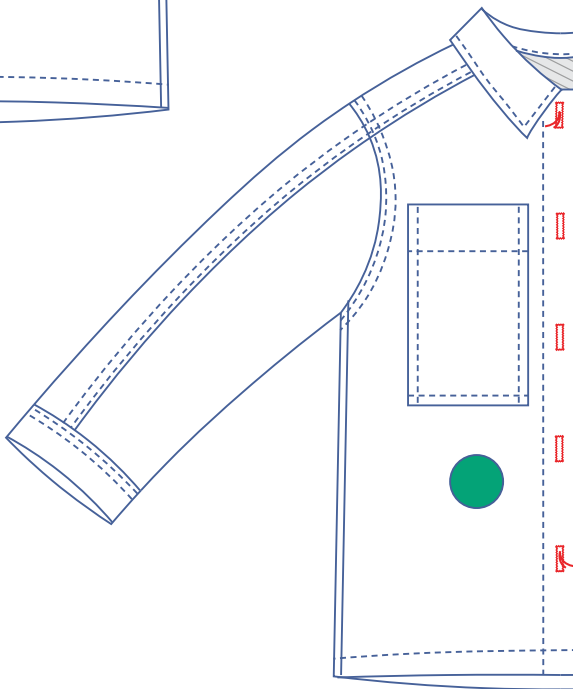

Make vertical buttonholes in the RF to match the buttons.