

# Kate by Fibre ⚡ood



# Kate by Fibre ood



4 - 32

Wearing Kate does your figure nothing but favours.

The seams down the bodice front and back create a clean, tailored fit at the bust and midriff. Kate's skirt flares elegantly towards the hem. The gathers at the shoulders of the butterfly sleeves add a whimsical touch. Now, add a row of buttons down the front – tone on tone or in a contrasting colour – and you've got a date with Kate! The location of the bottom button determines how much leg you show.

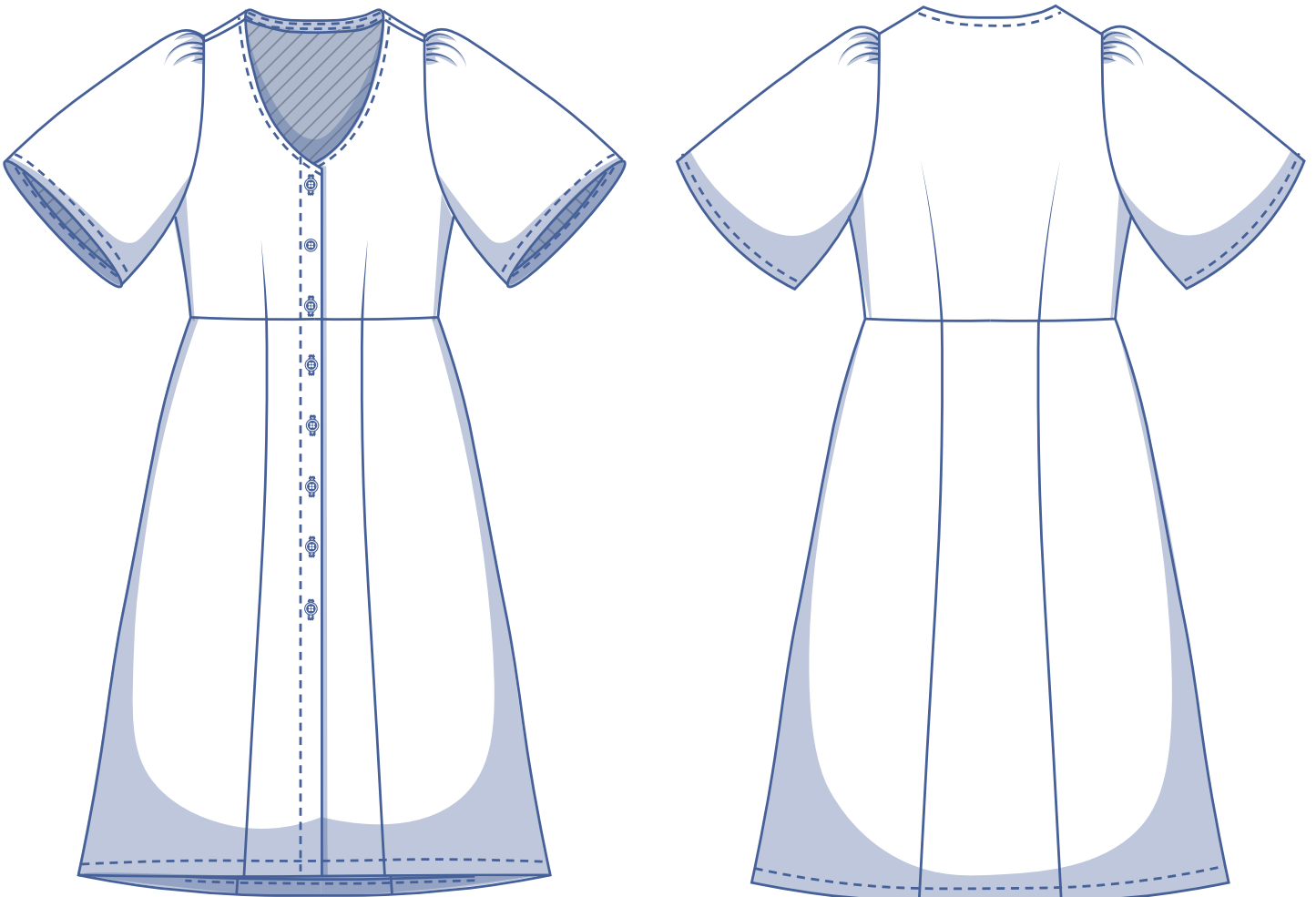

## size chart (in cm)

size	4	6	8	10	12	14	16	18	20	22	24	26	28	30	32
body height	160	164	166	167	168	169	170	171	172	172	172	172	172	172	172
B (bust)	76	80	84	88	92	96	100	104	110	116	122	128	134	140	146
W (waist)	66	68	70	74	78	82	84	88	94.5	101	107.5	114	120.5	127	133.5
H (hips)	86	90	94	97	100	103	106	109	115	120	125	130	135	140	145

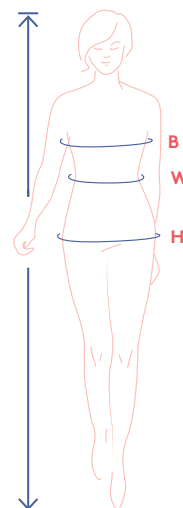

Choose your size based on your **bust measurement**. If your waist and hip measurements are wider than those in the size chart, check the size chart below to see if there is enough room or whether the pattern needs to be altered. It's easy to do. When tracing the pattern, simply trace from the line of one size to the line of the other.

## pattern measurements (in cm)

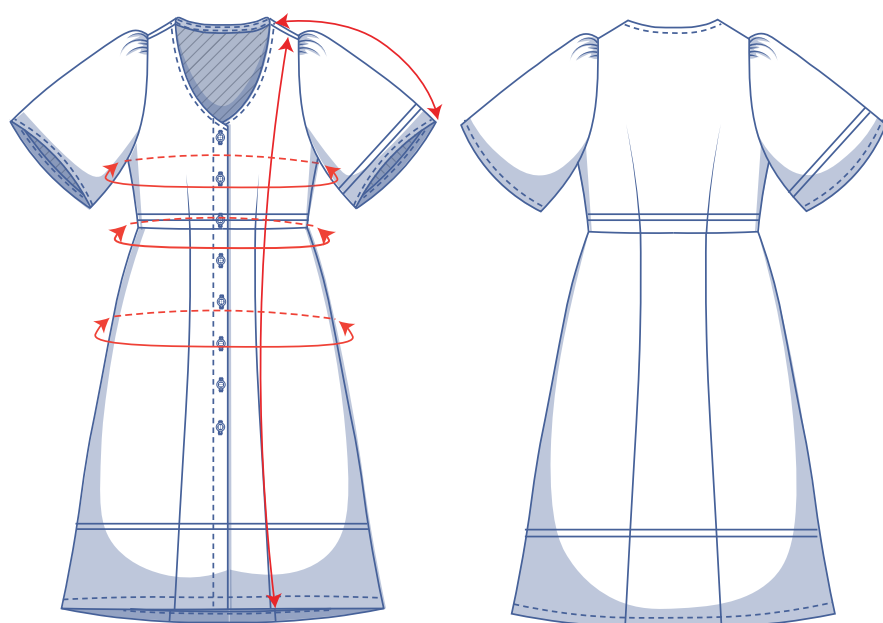

== shorten or lengthen the pattern here

This chart's measurements are the pattern measurements based on the fabric type and serve as a reference. Ease has been added to the width measurements (in addition to the exact body measurements) for a more comfortable fit. Kate is designed to have a **fitted bust and waist**.

size	4	6	8	10	12	14	16	18	20	22	24	26	28	30	32
length	123.5	124	124.5	125	125.75	126.25	126.75	127.25	129	130	130.75	131.5	132.25	133	134
sleeve length*	42	42.75	43.5	44	44.75	45.25	46	46.75	48	48.75	49.5	50.25	51	51.5	52.25
bust	82.5	86.5	90.5	94.5	98.5	102.5	106.5	110.5	116.5	122.5	128.25	134.25	140.25	146.25	152.25
waistline	73.25	75.25	77.25	81.25	85.25	89.25	91.25	95.25	101.75	108.25	114.75	121.25	127.75	134	140.5
hips	96.5	100.25	104	107	109.75	112.75	115.75	118.75	125.25	130	134.75	139.75	144.75	149.75	154.75

\* Including the shoulderlength.

Compare the stated lengths to the measured or desired lengths. **Lengthen** or **shorten** the dress and/or sleeves by cutting the pattern pieces at the indicated double lines. Then either increase the distance between the cut pieces by the desired amount (to lengthen) or overlap the pieces (to shorten). Make sure that the CF and CB lines and the side seams are always straight.



### IMPORTANT

Adjust the amount of fabric to be used based on these alterations.

## notions



- Thread
- Iron-on interfacing: max. 95 cm
- Buttons (Ø 1.8 cm): see table
- Fabric: see table

buttons	4	6	8	10	12	14	16	18	20	22	24	26	28	30	32
	9	9	9	9	9	9	9	9	10	10	10	10	10	10	10

fabric use		4	6	8	10	12	14	16	18	20	22	24	26	28	30	32
fabric width 110 cm	cm	290	295	295	300	330	335	335	340	345	355	440	445	450	455	460
fabric width 140 cm	cm	230	235	235	235	240	250	270	280	285	290	290	295	300	305	310

The corresponding fabric layout can be found on page 6 of these sewing instructions.

## fabric advice



Kate lends itself well to a variety of woven fabrics. For example, poplin, Tencel, linen, crepe, etc. all work. This pattern is flexible and looks great in both solids and prints.

# Proud to be #Sewista

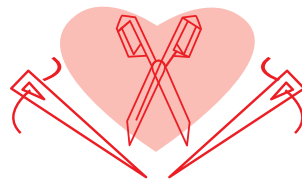

## pattern pieces & seam allowances (in cm)

To sew the garment as described in the instructions, draw the illustrated seam allowances around the paper pattern pieces before cutting them out. If you are using a PDF pattern, the pattern can be printed with or without seam allowance. To find out more, watch the [video](#).

1. front: 2x
2. skirt front: 2x
3. skirt front, side: 2x
4. back: 1x on fabric fold
5. skirt back: 1x on fabric fold
6. skirt back, side: 2x
7. sleeve: 2x
8. pocket: 4x
9. bias tape: 1x

**IMPORTANT**

The pieces highlighted in light yellow have iron-on interfacing attached to the wrong side.

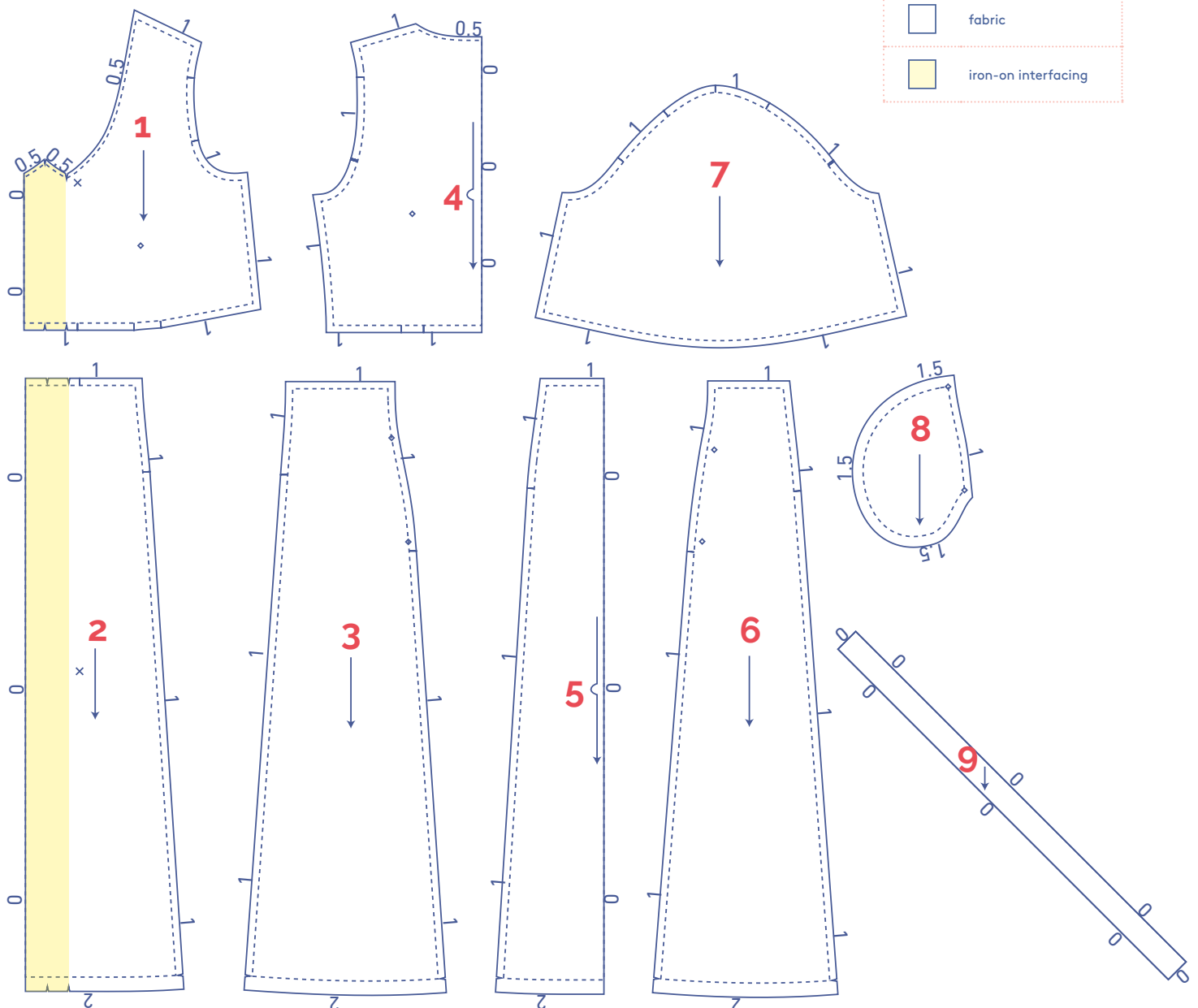

**fabric layout – solid fabrics**  
**fabric width 110 cm**

4 - 10

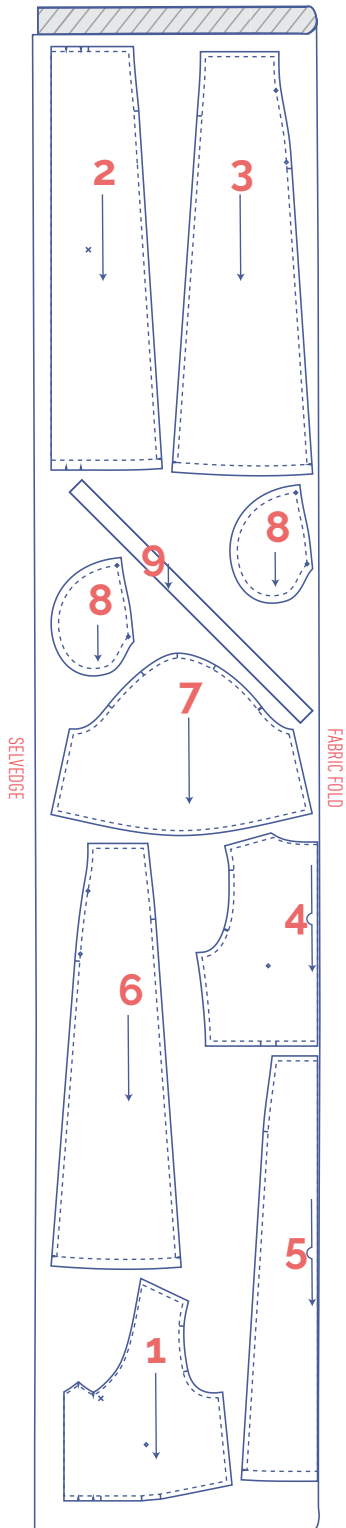

12 - 22

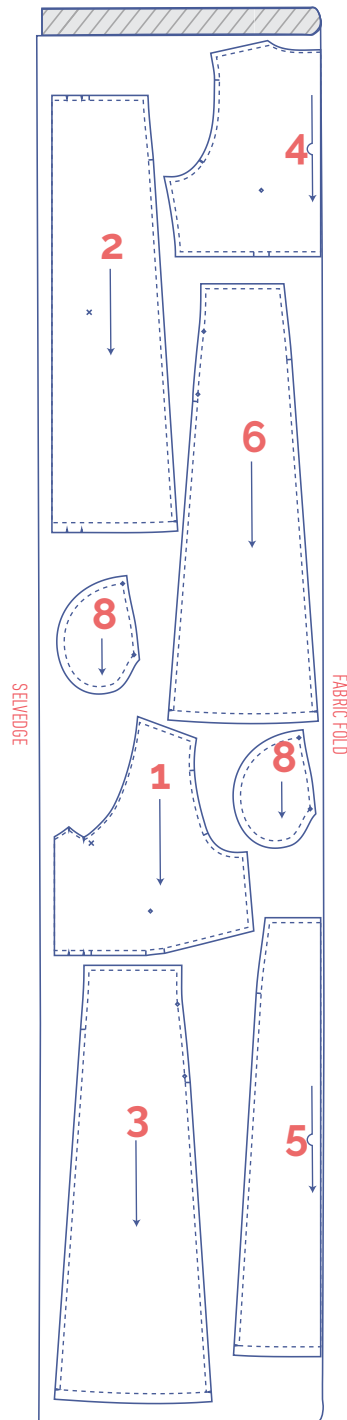

+

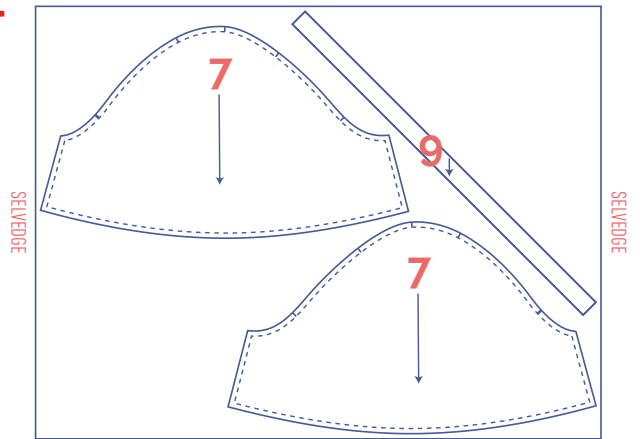

**IMPORTANT**

Because the fabric is opened out and single layer, you will also need to mirror images of pattern piece 7 so you have a left and a right sleeve.

**IMPORTANT**

You only need pattern piece 9 once.

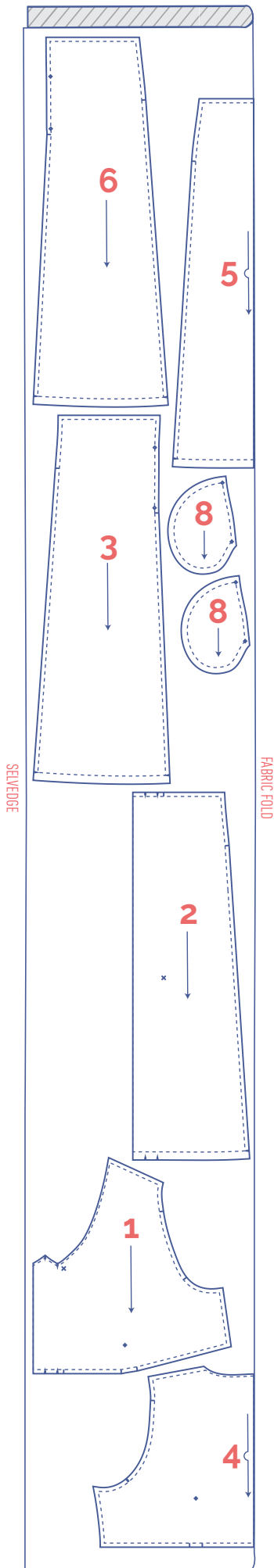

+

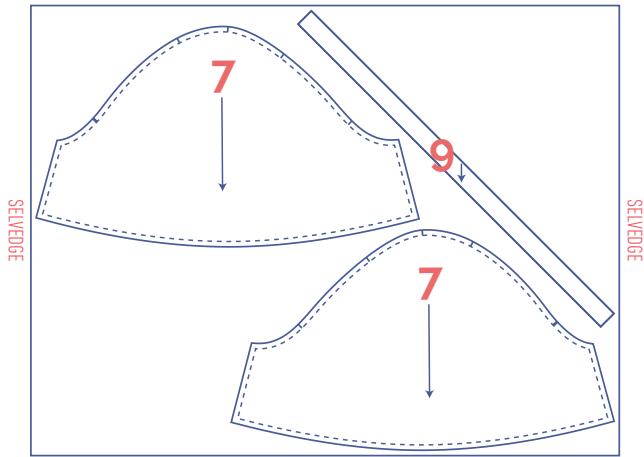

**IMPORTANT**

Because the fabric is opened out and single layer, you will also need to mirror images of pattern piece 7 so you have a left and a right sleeve.

**marking pattern pieces**



Notch the pattern paper and fabric at the following points



single notch



double notch



V-notch/fabric fold



Mark the following points with marking thread



centre point



snap fastener

**fabric layout – solid fabrics**  
**fabric width 140 cm**

4 - 16

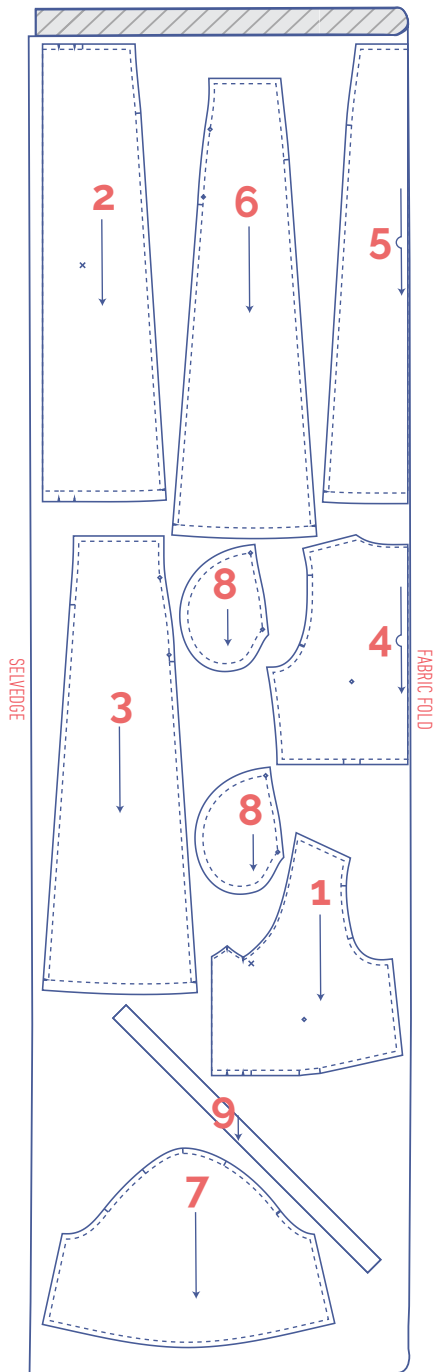

**IMPORTANT**

You only need pattern piece 9 once.

18 - 28

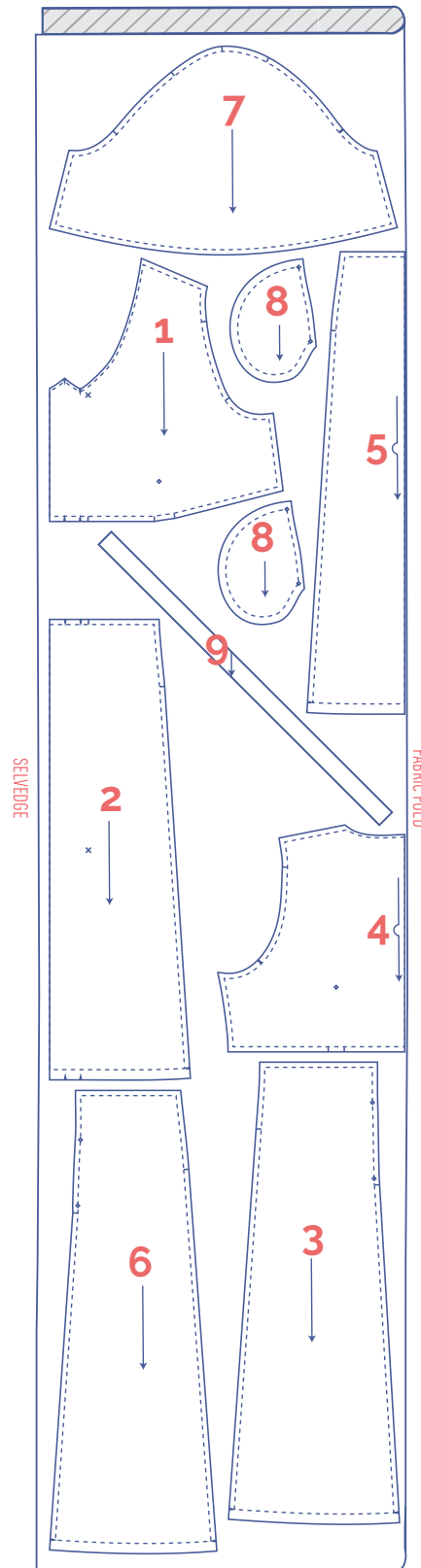

**IMPORTANT**

You only need pattern piece 9 once.



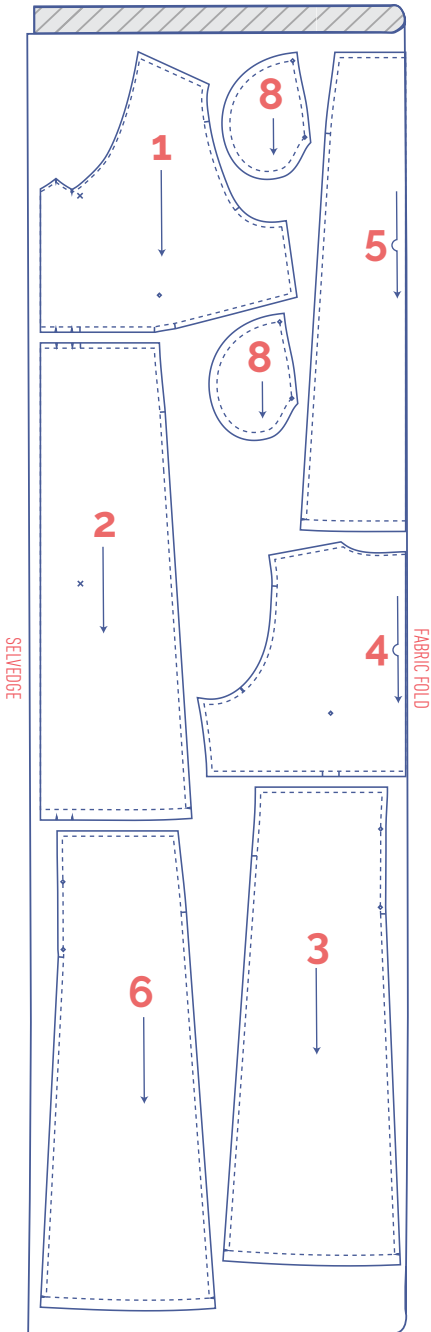

+

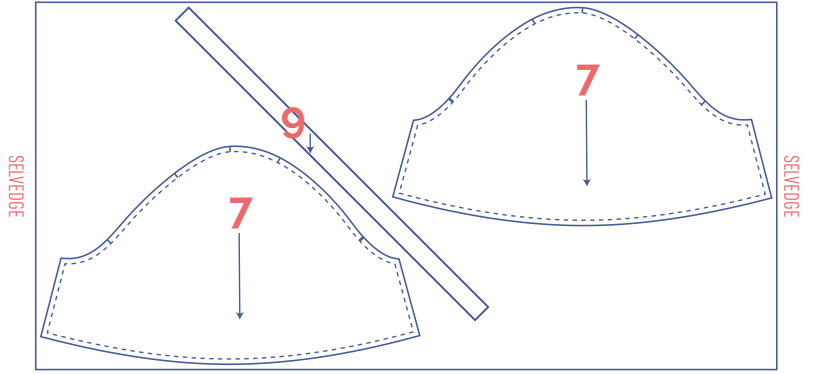



**IMPORTANT**

Because the fabric is opened out and single layer, you will also need to cut mirror images of pattern piece 7, so you have a left and right sleeve.

**marking pattern pieces**

	Notch the pattern paper and fabric at the following points
	single notch
	double notch
∨	V-notch/fabric fold

	Mark the following points with marking thread
	centre point
	snap fastener

# sewing instructions



The method used to finish the seams depends on the fabric used. The pieces are always sewn together with the right sides of the fabric facing, unless stated otherwise.



F front

B back

CF centre front

CB centre back

RF right front ●

LF left front ●

□ right side

▨ wrong side

▨ iron-on interfacing

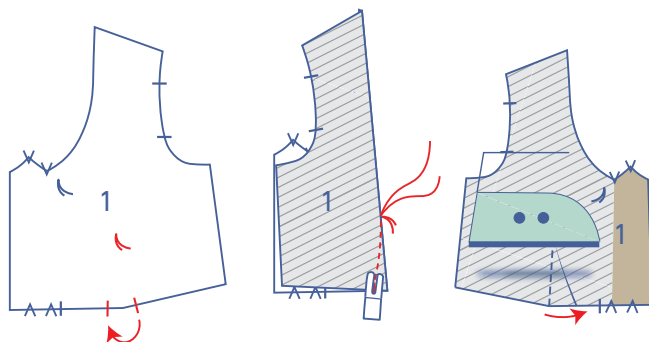

## 1

Fold the bodice at the bottom of the front (1) together with the right sides of the fabric touching, matching notches. Sew the waist dart in a slightly curved line towards the marking thread. Sew up to and just past the marking thread, so that you've sewn past the fabric. Snip the threads and tie a knot.

Turn the front over so that the wrong side is facing up. Press the dart allowance towards the CF.

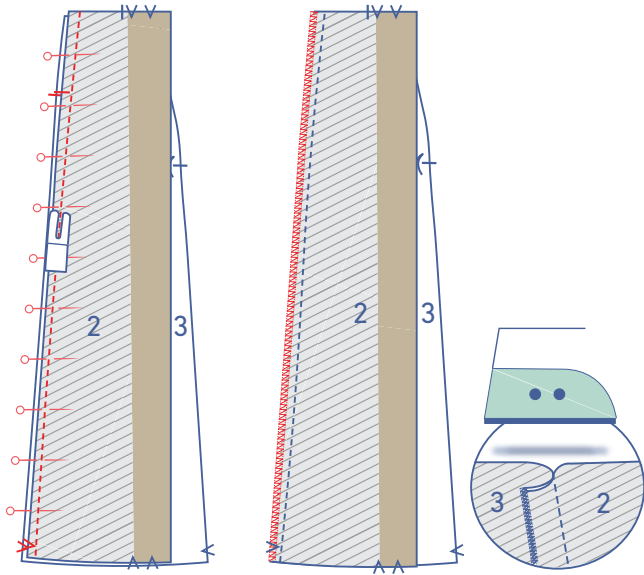

Pin and sew the seams of the skirt front (2) and skirt front side (3) pieces together, matching the markings.

Finish the raw edges with overlock stitching. Press the seam allowance towards the skirt front side.

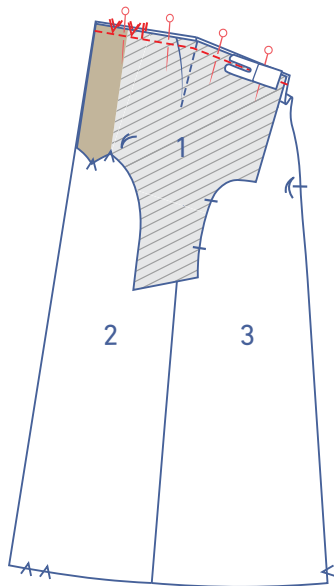

Pin and sew the bodice and skirt fronts together, matching the markings. The darts on the bodice and seams of the skirt should match.

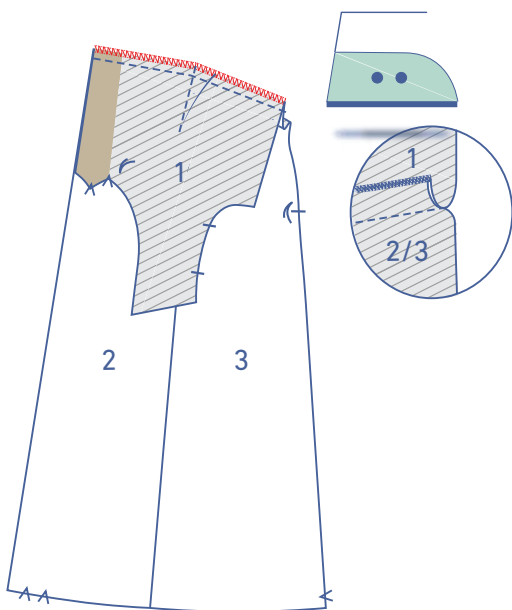

Finish the raw edges with overlock stitching. Press the seam allowance towards the front.

Finish the raw edges of the front and pocket pieces (8) where indicated with overlock stitching.

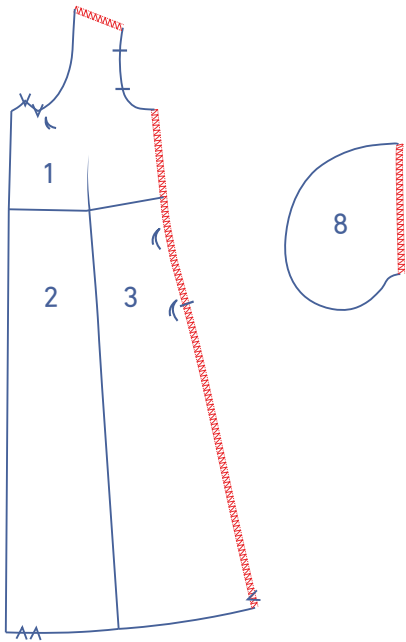

Pin the indicated ends of two of the four pocket pieces to the sides of the skirt front side pieces, matching the marking threads. Sew into place between the marking threads.

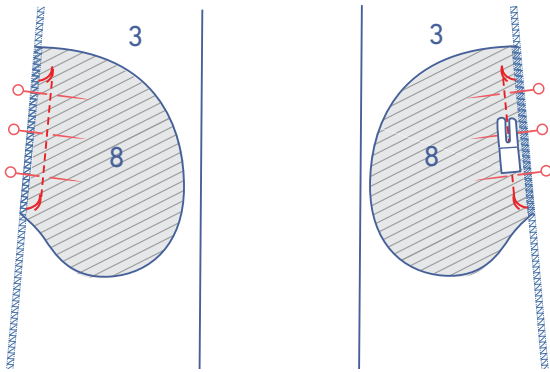

Fold the pocket and seam allowance over and sew the pocket to the seam allowance underneath between the marking thread.

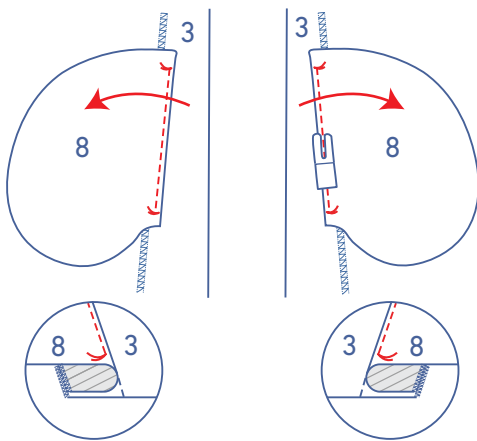

## 2

Fold the bodice at the bottom of the back (4) together with the right sides of the fabric touching. Sew the dart in a slightly curved line towards the marking thread. Sew up to and just past the marking thread, so that you've sewn past the fabric. Snip the threads and tie a knot.

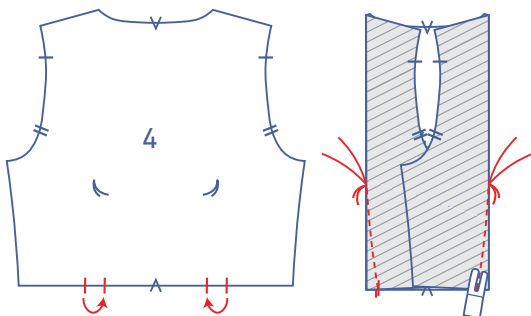

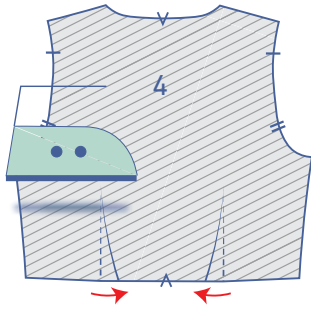

Turn the back over so that the wrong side is facing up. Press the dart towards the CB.

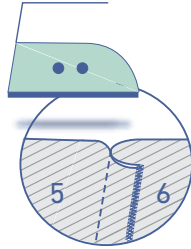
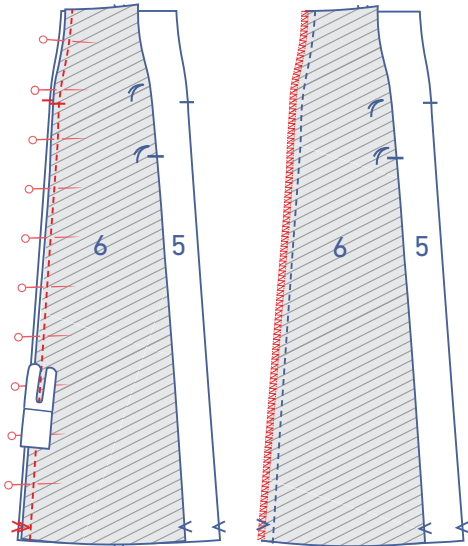

Pin and sew the seams of the skirt back (5) and skirt back side (6) pieces together, matching the markings.

Finish the raw edges with overlock stitching. Press the seam allowance towards the skirt back side.

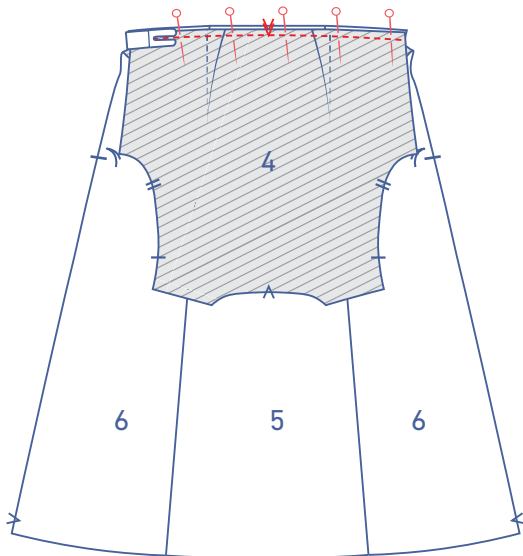

Pin and sew the bodice and skirt backs together, matching the markings. The darts on the bodice and seams of the skirt should match.

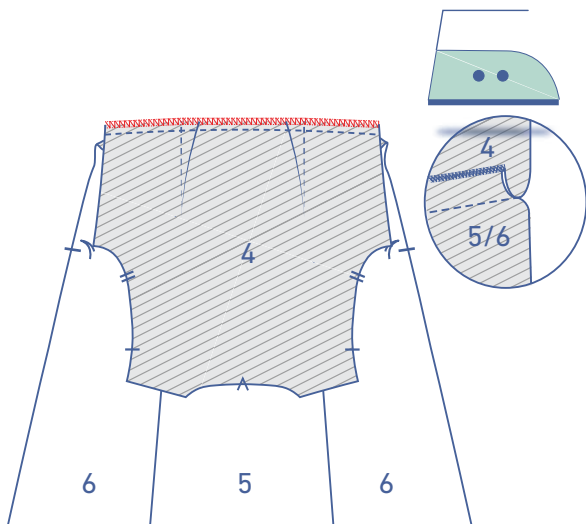

Finish the raw edges with overlock stitching. Press the seam allowance towards the back.

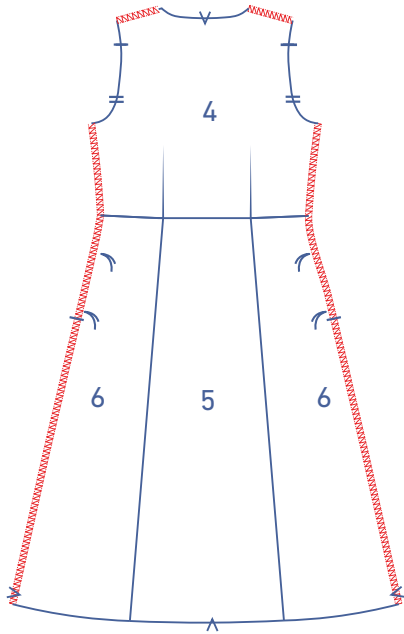

Finish the raw edges of the back where indicated with overlock stitching.

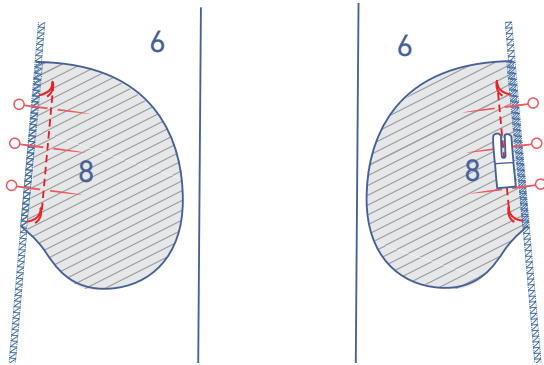

Pin the indicated ends of the two remaining pocket pieces to the sides of the skirt back side pieces, matching the marking threads. Sew into place between the marking threads.

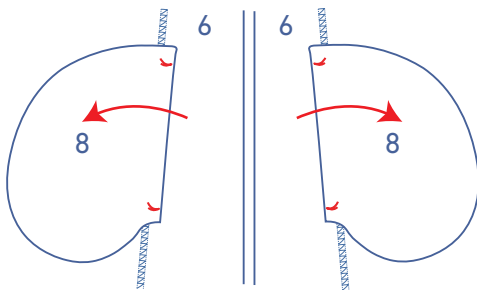

Fold the pocket pieces over.

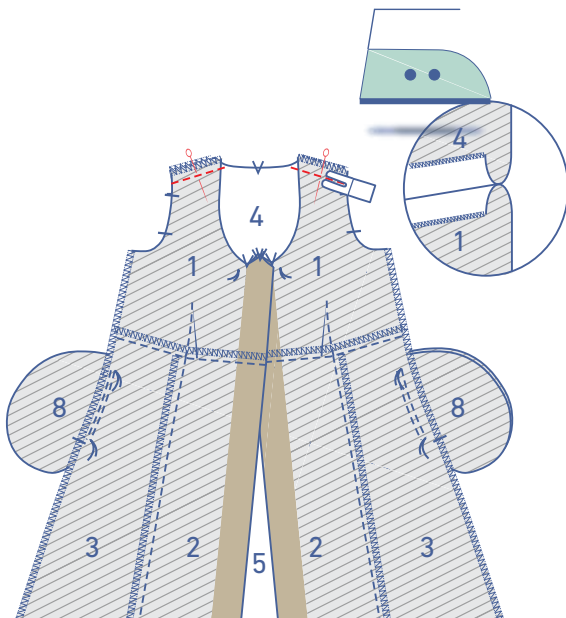

### 3

Pin the shoulder seams together and sew. Press the seam allowance open.

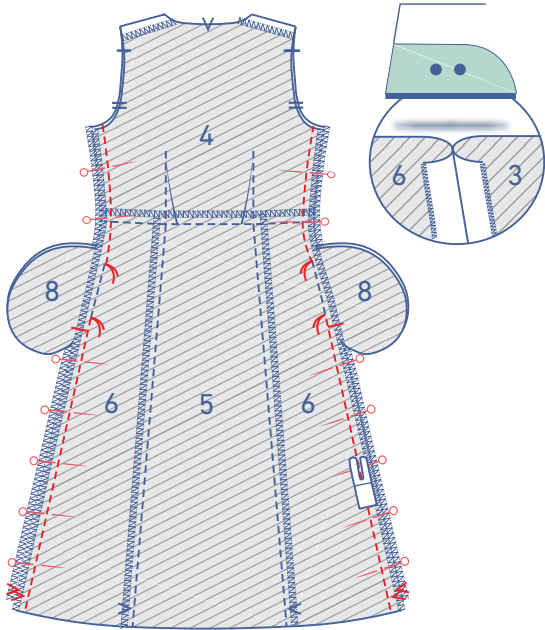

**4**

Pin and sew the side seams together. Sew from the underarm until the marking threads that mark the top of the pocket opening. Then, continue sewing from the next set of marking threads to the hem. Press the seam allowance open.

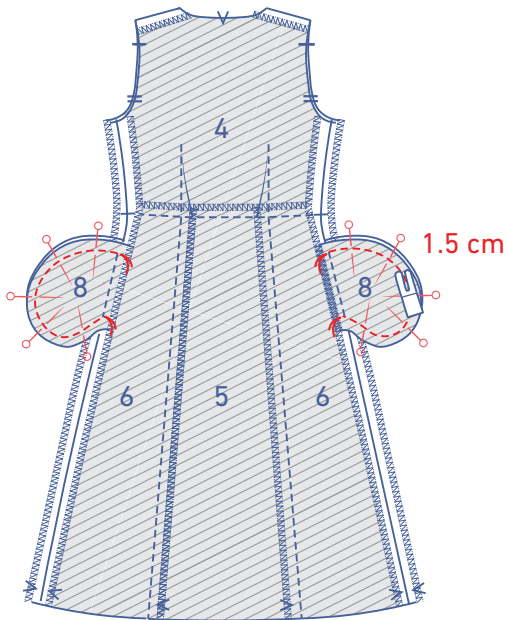

Pin and sew the contours of the pocket pieces together at 1.5 cm from the raw edges.

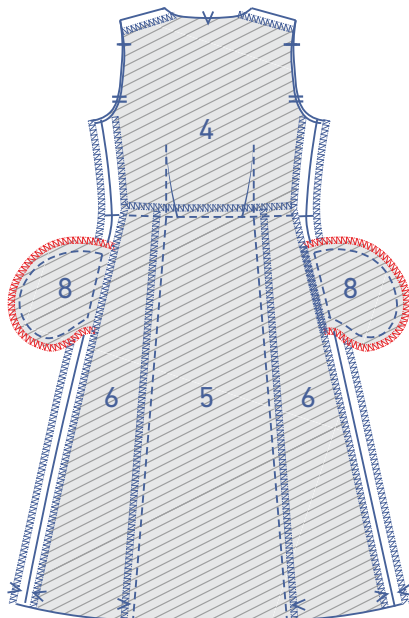

Finish the raw edges with overlock stitching.

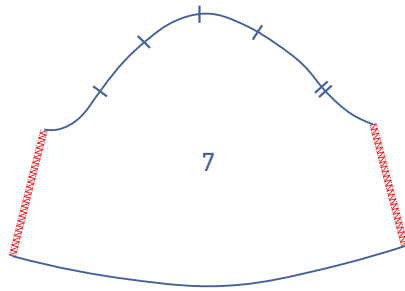

## 5

Finish the sleeve sides (7) with overlock stitching.

Fold the sleeve in half with the right sides touching. Pin and sew the underarm seam. Press the seam allowance open.

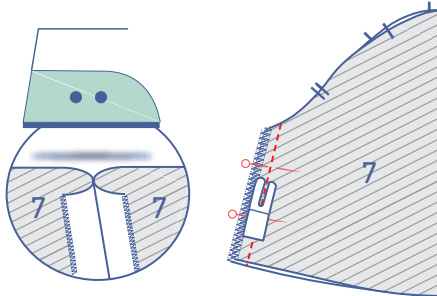

Using a long stitch length at a low thread tension, sew the top of the sleeve with two lines of parallel stitching until just past the indicated single notches. Leave a length of thread at the start and end of your stitching.

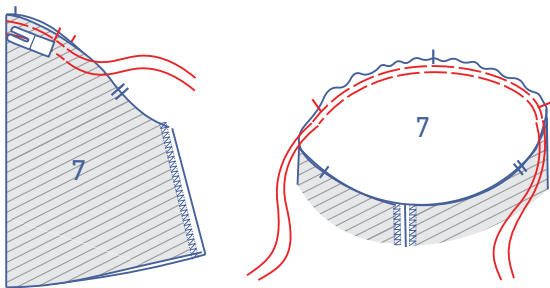

Gently tug the ends of the threads to gather the fabric.

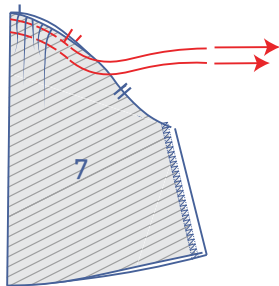

Pin and sew the top of the sleeve (= sleeve cap) to the armhole, matching the notches. The single notch closest to the underarm marks the front, while the double notch marks the back. The single notch at the top aligns with the shoulder seam. Arrange the gathers between the single notches on either side of the top of the sleeve.

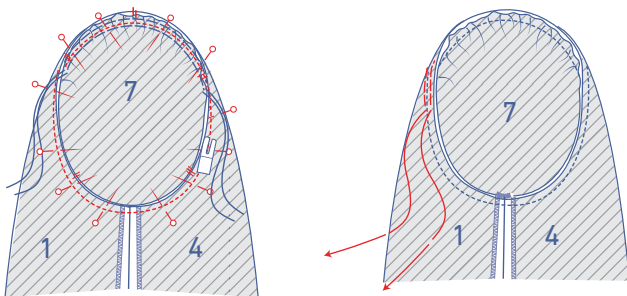

Remove the gathering threads.

Finish the raw edges with overlock stitching.

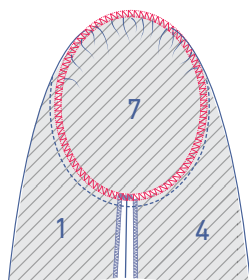



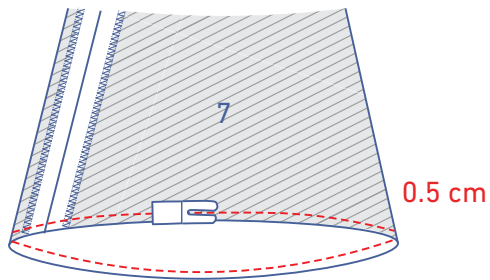

Sew all the way around the bottom of the sleeve at 0.5 cm from the raw edge.

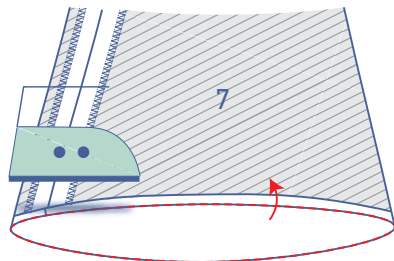

Then, press the edge towards the wrong side along the stitching.

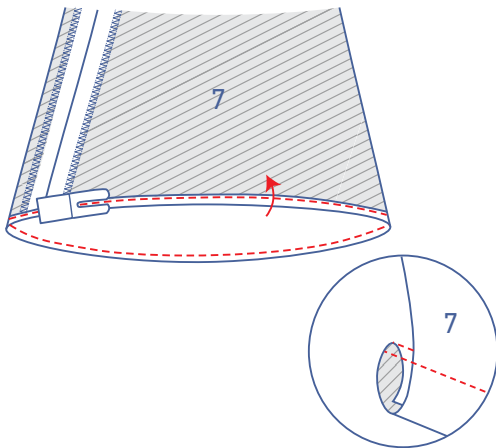

Turn the edge up again towards the wrong side. Sew into place right next to the edge.

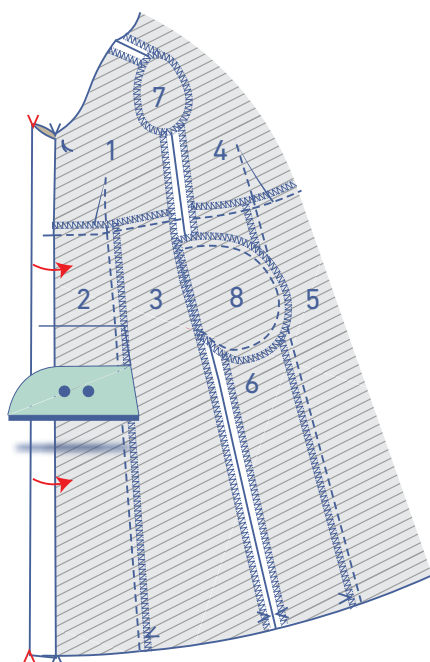

## 6

Press the front facing towards the wrong side at the first set of V-notches at the top and bottom.

Press the facing over again at the second set of V-notches at the top and bottom.

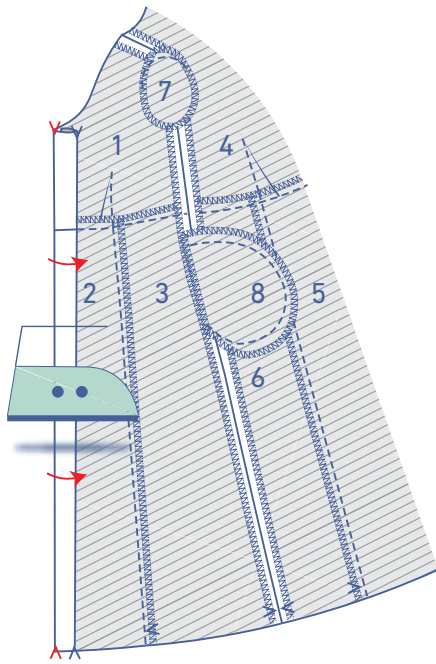

Then, fold the facing back towards the right side at the second V notch as shown, then pin temporarily.

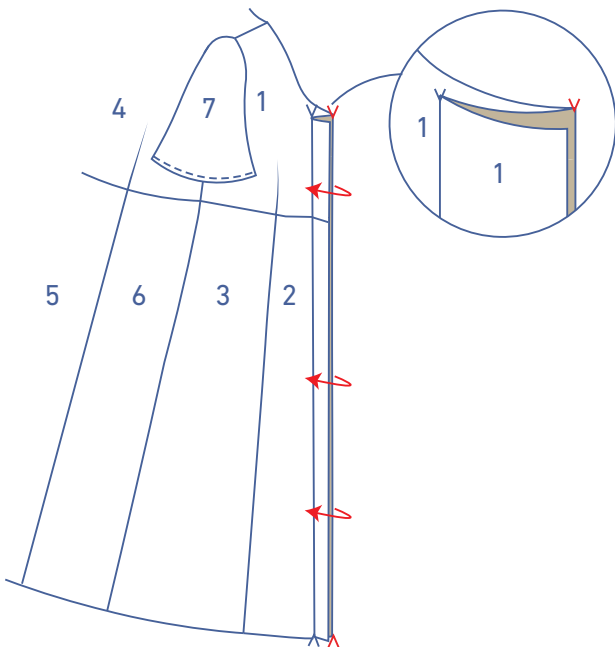

Fold the bias tape (9) in half with the long ends together and the wrong sides of the fabric facing each other and press.

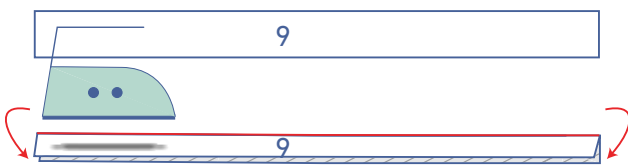

Pin the raw edges of the bias tape to the right side of the neckline. The ends should be on top of the folded facing.

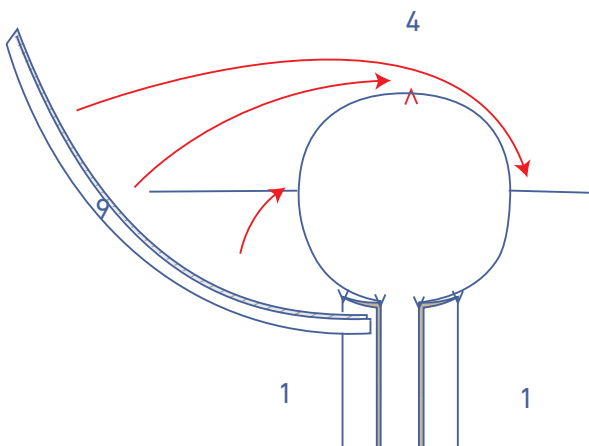

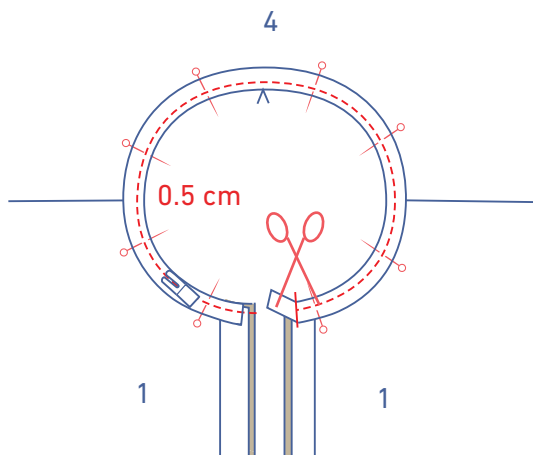

Sew the bias tape into place at 0.5 cm from the neckline. Snip off any excess bias tape (the exact length is not provided because the grainline is on the bias, i.e. it will differ according to fabric type).

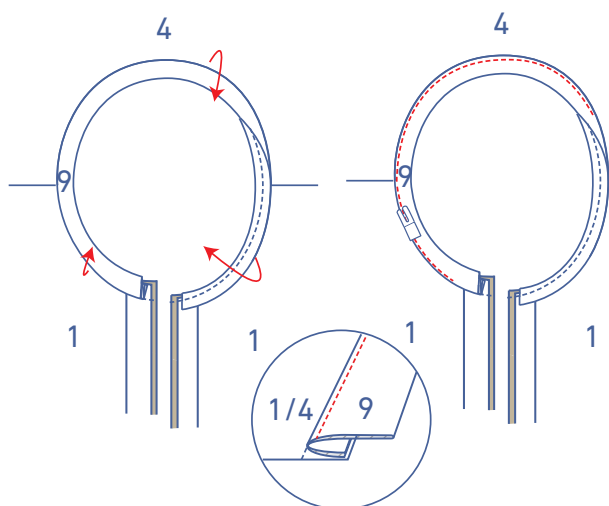

Fold the bias tape over and sew to the seam allowance underneath, right next to the seam.

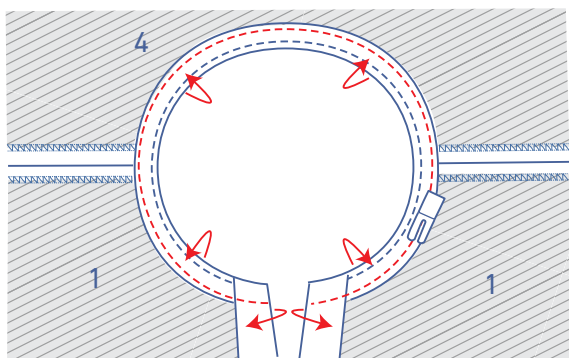

Fold the bias tape and the folded facing towards the wrong side and edgestitch into place.

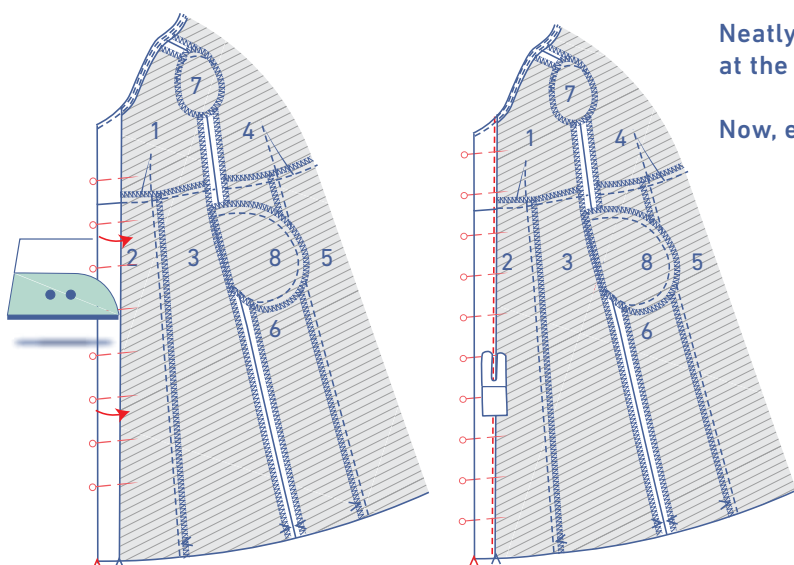

Neatly press the facing of the CF towards the wrong side at the indicated V notch at the bottom and pin into place.

Now, edgestitch into place.

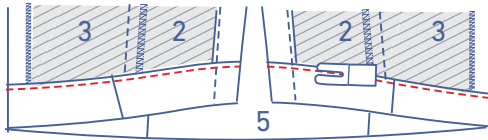
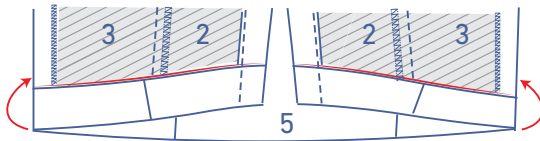
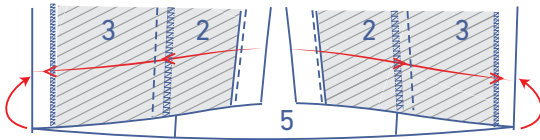
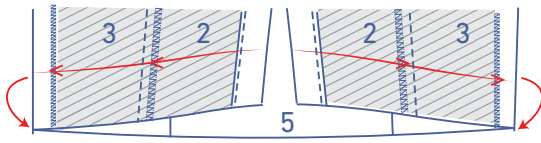
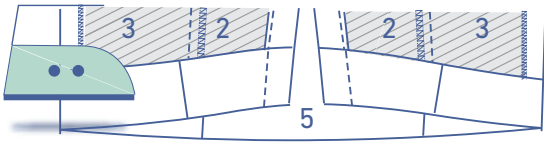

## 7

Turn the hem allowance towards the wrong side, press, and then open back out.

Fold the raw edge to meet the pressed fold line and then fold over again.

Edgestitch into place.

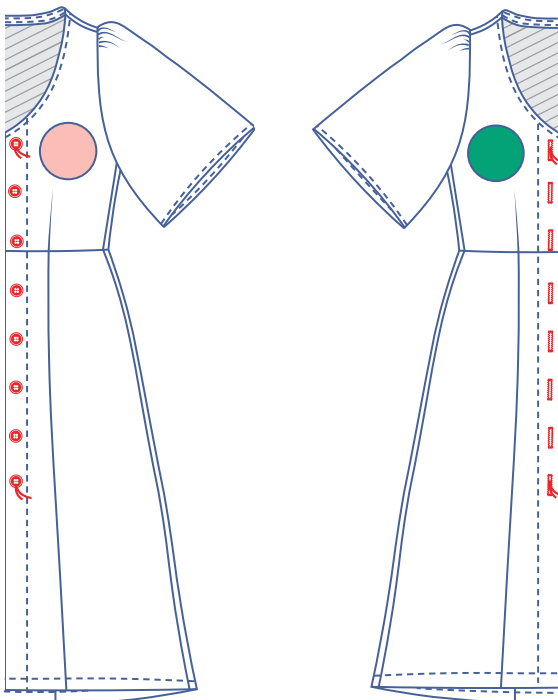

## 8

Sew the buttons onto the LF. The top and bottom button locations have been marked on the pattern for you. Evenly divide the distance between them to determine the location of the other buttons.

Make vertical buttonholes in the RF to match the buttons.

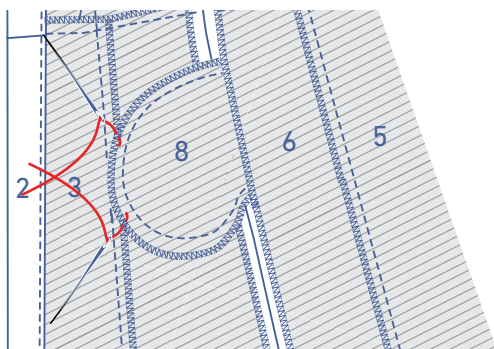

Secure the pockets with a few stitches to the seam allowance of the skirt front and skirt front side.