

Hortence by Fibre ⚡ood



Hortence by Fibre



XS - XXXL

A combination of distinguished and whimsical. Hortence is fitted at the top, but flares out with a tiered skirt.

With a gorgeous, smocked yoke, standing collar, and wide sleeves – this dress is contemporary with a sweet nostalgic feel. Would a Hortence top suit you better?

Simply lengthen the front and back and omit the two flounces at the bottom. That's all there is to it!

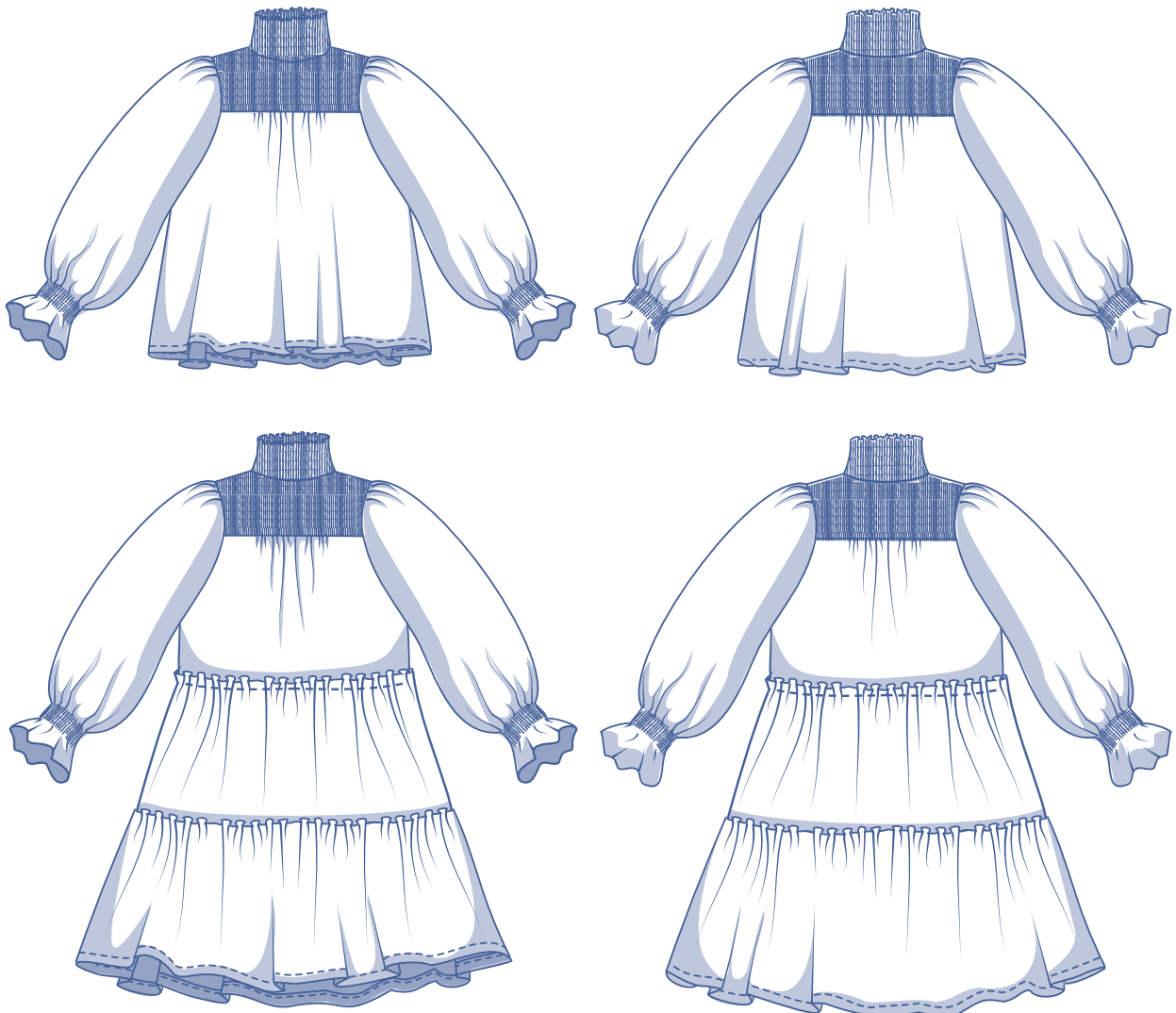

size chart (in cm)

size	XS		S		M		L		XL		XXL		XXXL		
	4	6	8	10	12	14	16	18	20	22	24	26	28	30	32
body height	160	164	166	167	168	169	170	171	172	172	172	172	172	172	172
B (bust)	76	80	84	88	92	96	100	104	110	116	122	128	134	140	146

Choose your size based on your **bust measurement**. Pick the size that is the best match for your bust.

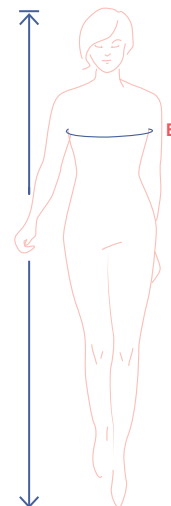

pattern measurements (in cm)

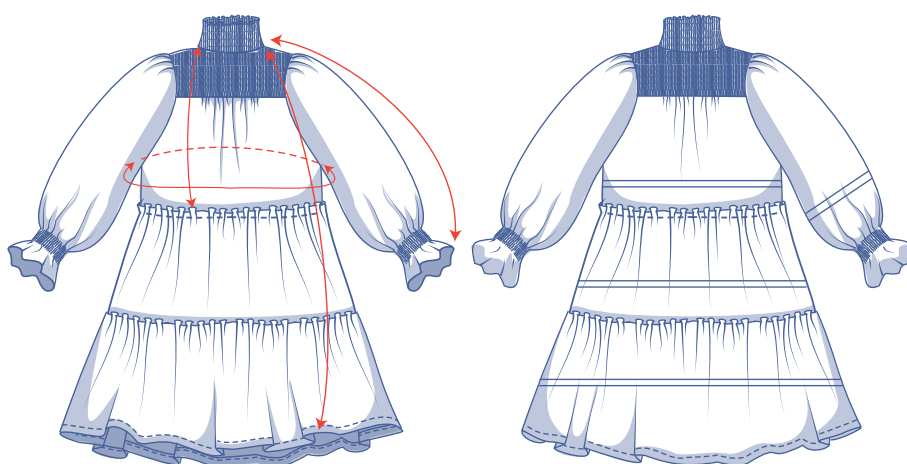

== shorten or lengthen the pattern here

This chart's measurements are the pattern measurements based on the fabric type and serve as a reference. Ease has been added to the width measurements (in addition to the exact body measurements) for a more comfortable fit. Hortence is designed to have a **loose cut**. Depending on the preferred cut, you could go a size smaller or larger than the recommended size.

size	XS	S	M	L	XL	XXL	XXXL
dress length	88.75	89.75	90.75	93	95.5	98.25	99.75
top length*	60.25	62	63.75	65.75	68	70.25	72.5
sleeve length**	69.75	71.25	73	74.5	76	77.75	79.25
bust	99.75	108.25	116.75	125.25	135.5	148	160.5

* To make the top, lengthen pattern pieces 3 and 4 until you have this total length (incl. the top piece).

** Including the shoulder length.

Compare the stated lengths to the measured or desired lengths. **Lengthen** or **shorten** the dress and/or the sleeves by cutting the pattern pieces at the indicated double lines. Then either increase the distance between the cut pieces by the desired amount (to lengthen) or overlap the pieces (to shorten). Make sure that the CF and CB lines and the side seams are always straight.



IMPORTANT

Adjust the amount of fabric to be used based on these alterations.

notions



- Thread
- Elastic thread: 2 bobbins
- Fabric: see table.

fabric use (top)		XS	S	M	L	XL	XXL	XXXL
fabric width 110 cm	cm	220	225	230	235	290	300	315
fabric width 140 cm	cm	170	175	180	185	240	245	250

fabric use (dress)		XS	S	M	L	XL	XXL	XXXL
fabric width 110 cm	cm	305	310	370	385	410	440	465
fabric width 140 cm	cm	235	255	270	285	300	370	390

The corresponding fabric layout can be found on page 6 of these sewing instructions.

fabric advice



A soft drape fabric is the only way to go for the romantic Hortence. We recommend gauze or double gauze, (viscose) crepe, silk, satin, etc. Solid or patterned? You pick. Woven fabrics are the best option for shirring.

Proud to be #Sewista

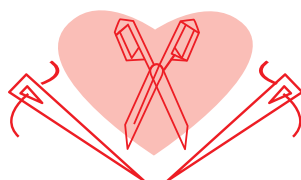

pattern pieces & seam allowances (in cm)

To sew the garment as described in the instructions, draw the illustrated seam allowances around the paper pattern pieces before cutting them out. If you are using a PDF pattern, the pattern can be printed with or without seam allowance. To find out more, watch the [video](#).

1. top piece front: 1x on fabric fold
2. top piece back: 1x on fabric fold
3. front: 1x on fabric fold
4. back: 1x on fabric fold
5. skirt front: 1x on fabric fold
6. skirt back: 1x on fabric fold
7. bottom skirt front: 1x on fabric fold
8. bottom skirt back: 1x on fabric fold
9. collar: 1x on fabric fold
10. sleeve: 2x
11. rectangle front: 1x on fabric fold
12. rectangle back: 1x on fabric fold
13. rectangle collar: 1x on fabric fold

Pattern pieces '5 and 6' and '7 and 8' are the same.

IMPORTANT

Wait before cutting pattern pieces 1, 2 and 9 from the fabric. First, cut out pattern pieces 11, 12 and 13. Smock these and then cut pattern pieces 1, 2 and 9 from the smocked rectangles. Don't worry! The sewing instructions explain this process in detail.

NOTE

To make the Hortence top, lengthen pattern pieces 3 and 4 to your preferred length (incl. pieces 1 and 2), and don't forget to add 2 cm of hem allowance. You don't need pieces 5, 6, 7 or 8 for the top. When lengthening, make sure there is enough ease at the hem. To add more ease, draw a new CF and CB line parallel to the previous CF and CB lines. That will create more gathers between the single notches in pattern pieces 1 and 2.

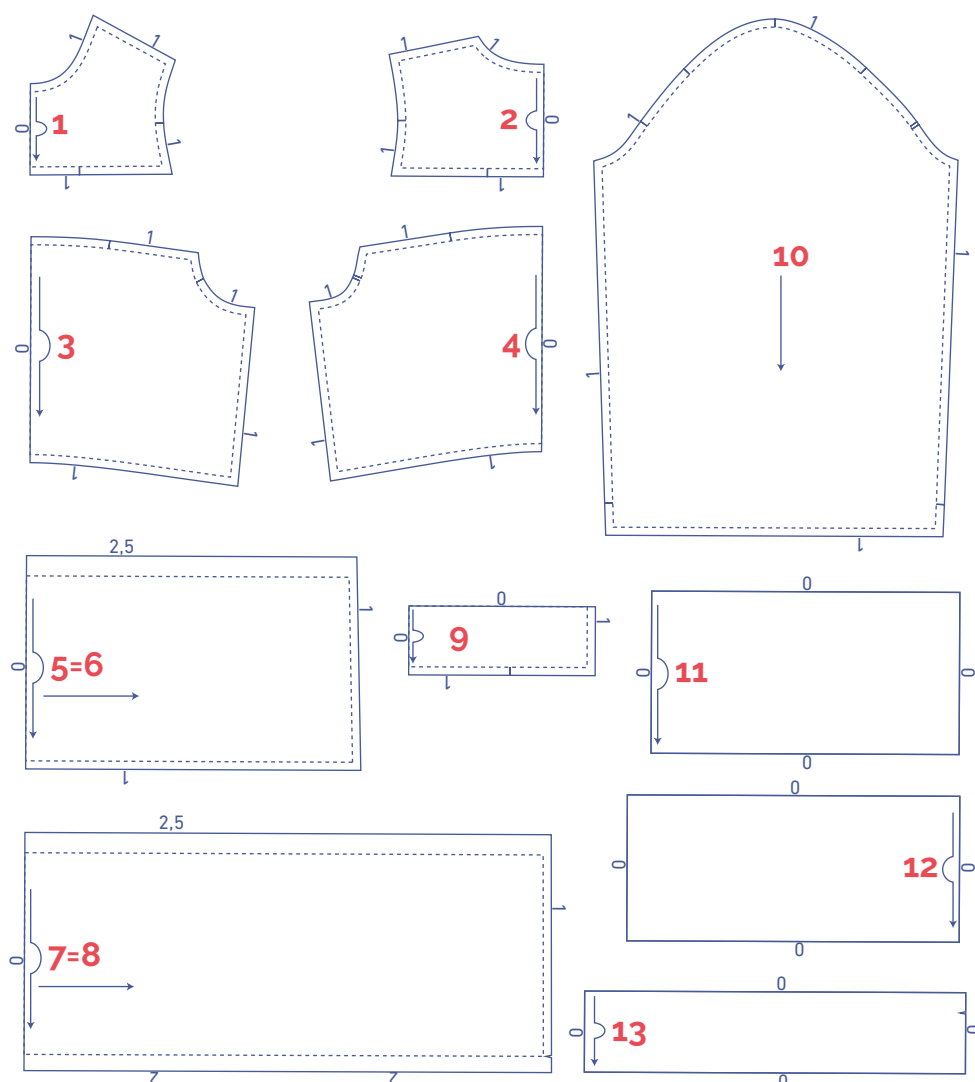

fabric layout – solid fabrics
fabric width 110 cm

XS - S

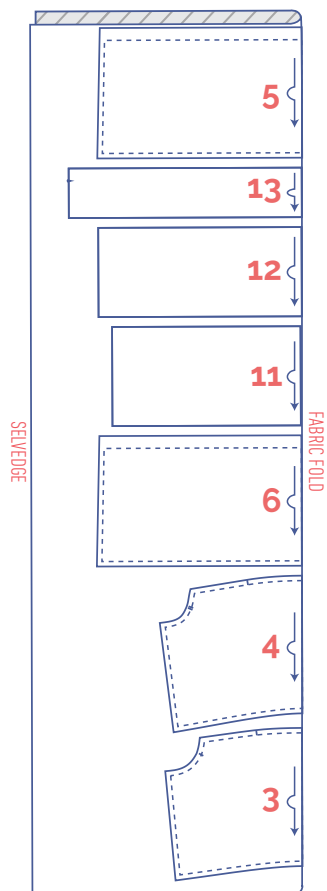

+

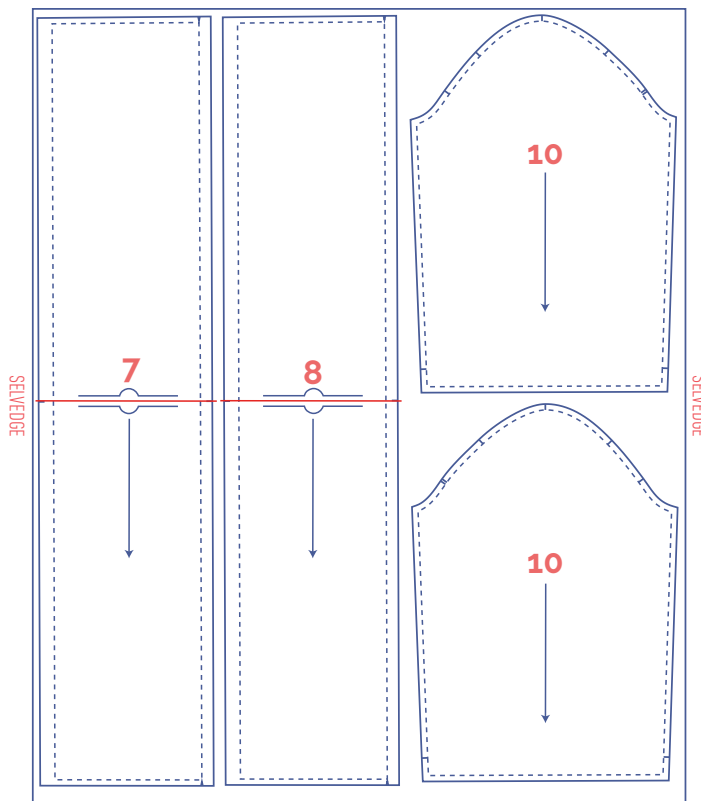

IMPORTANT

Be sure to cut the mirror image of pattern piece 10.

IMPORTANT

Pattern pieces 7 and 8 have been rotated at a 90° angle to fit on the fabric. If you chose patterned or napped fabric, you will need extra fabric.

M - XXXL

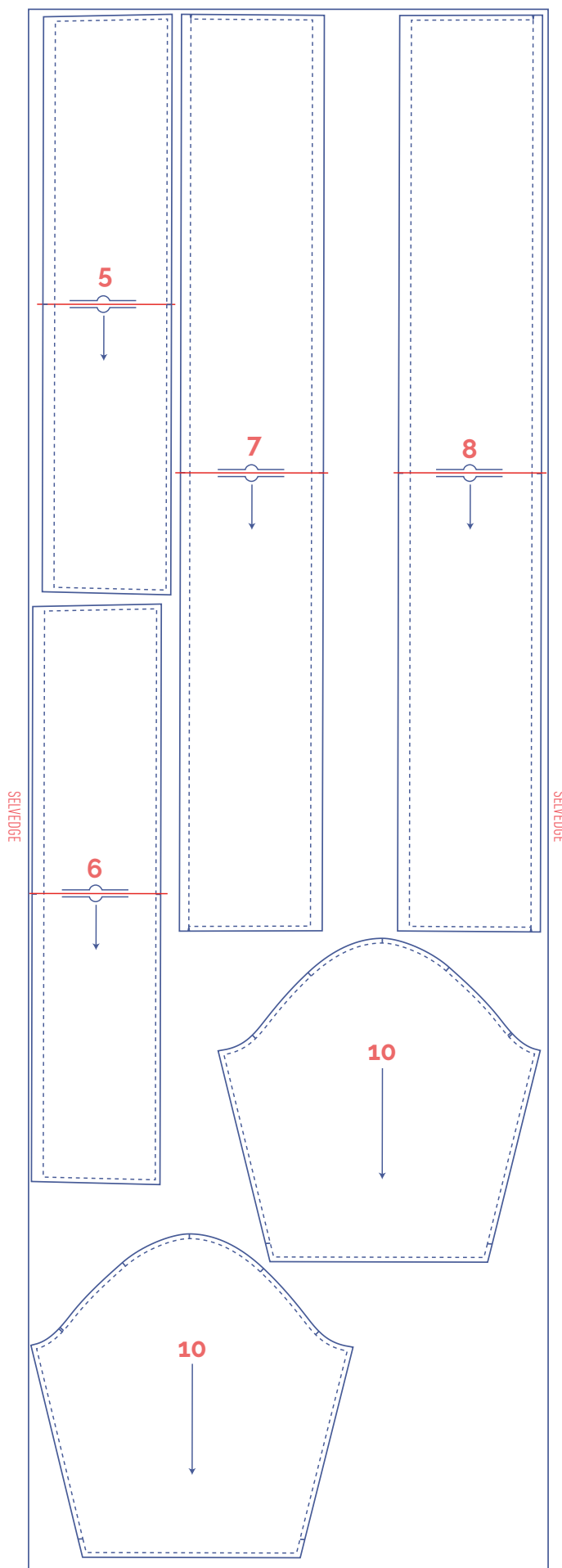
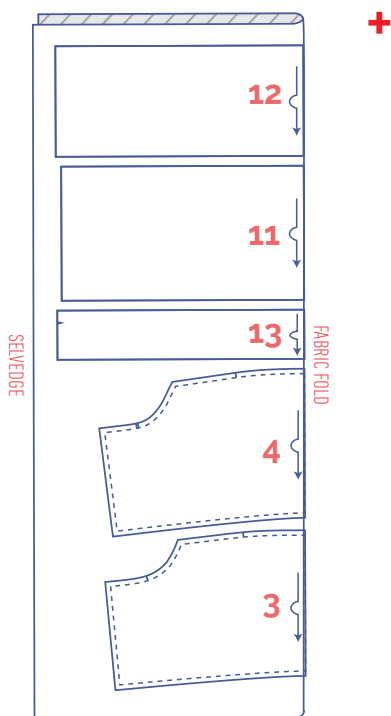

IMPORTANT

Pattern pieces 5, 6, 7 and 8 are arranged to fit this fabric width in the direction indicated. You will need extra fabric if you selected a patterned or napped fabric. If your fabric is wider, cut these pieces from the fabric along the straight grain.

IMPORTANT

Be sure to cut the mirror image of pattern piece 10.

fabric layout – solid fabrics
fabric width 140 cm

XS

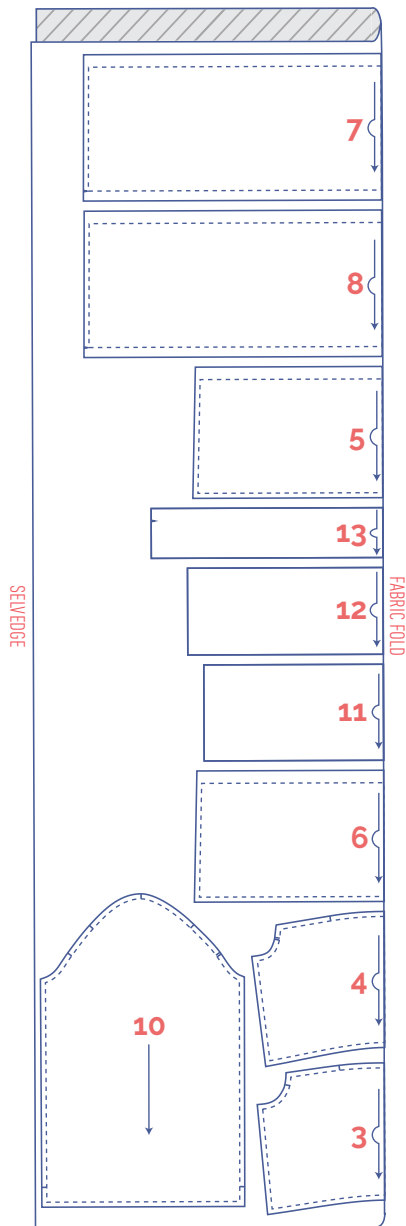

S - XXXL

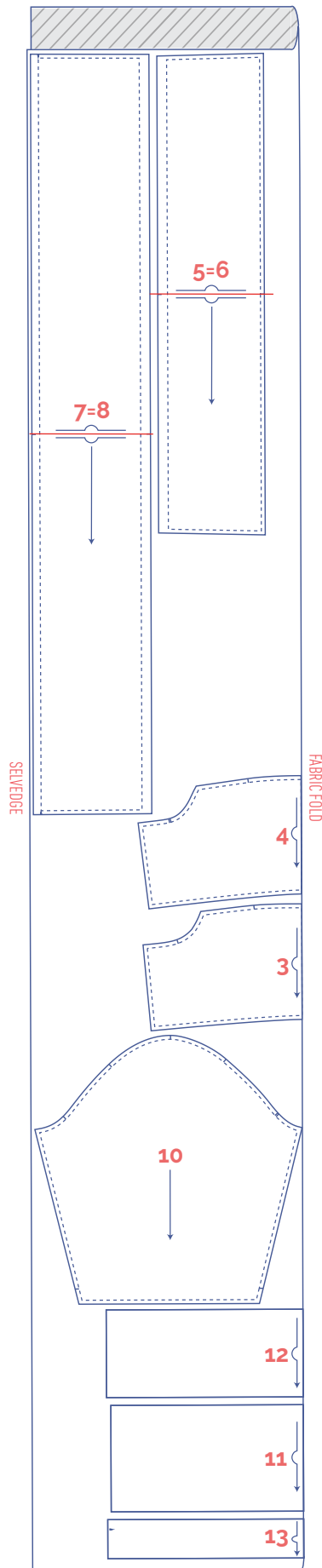

IMPORTANT

Pattern pieces 5, 6, 7 and 8 are arranged to fit this fabric width in the direction indicated. You will need extra fabric if you selected a patterned or napped fabric. If your fabric is wider, cut these pieces from the fabric along the straight grain.

marking pattern pieces

	notch the pattern paper and fabric at the following points
	single notch
	double notch
V	V notch

sewing instructions



The method used to finish the seams depends on the fabric used. The pieces are always sewn together with the right sides of the fabric facing, unless stated otherwise.

NOTE

Smocking is a traditional embroidery technique that involves gathering fabric in multiple parallel bands. We used elastic thread to gather the fabric (=shirring).

Good to know:

- Only use elastic thread for the lower thread (= your bobbin); normal sewing thread is used for the upper thread.
- Your shirring will rely on a standard straight stitch, i.e. you do not need an elastic stitch. The bobbin has to be wound by hand. Using your sewing machine to wind will overextend the elastic thread.
- To get the shirring effect you're going for, you'll need to tinker with the stitch length (settings 3-4.5). The longer your stitch length, the more gathers and the smaller your piece of fabric. Your goal is to shrink your fabric by half, approximately, based on the direction of your stitching. If the lower thread (= gathering thread) is nice and taut, you can adjust the pattern of gathers after sewing by tugging the ends of the gathering threads.
- Always test your machine's settings on a fabric swatch first to get it right!
- And always steam the pieces you've smocked. Steaming makes the fabric shrink even more. To do this, hover your iron over the pieces and hit the steam button. Never press onto the fabric directly.
- If the tips above don't produce the look you have in mind, try sewing the same stitching line again to shrink/gather the fabric more.

F front

B back

CF centre front

CB centre back

 right side

 wrong side

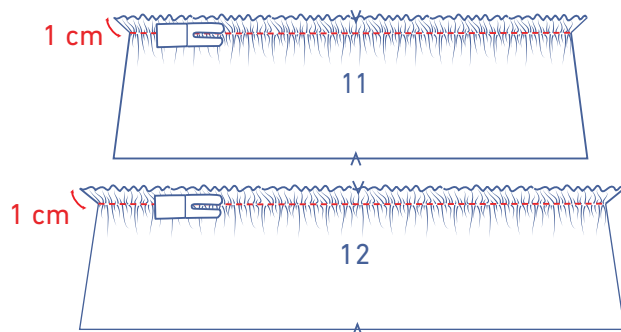
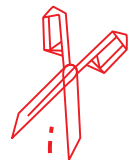

1

Using elastic thread in the bobbin, sew a straight line parallel to and 1 cm away from the long ends of the rectangle front (11). Follow the same process to the piece rectangle back (12).

1 cm

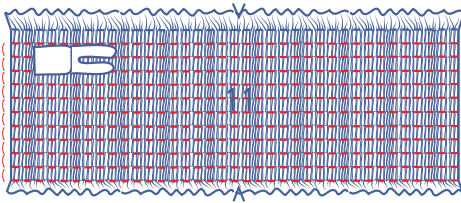

1 cm

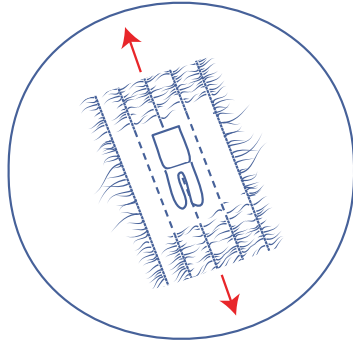
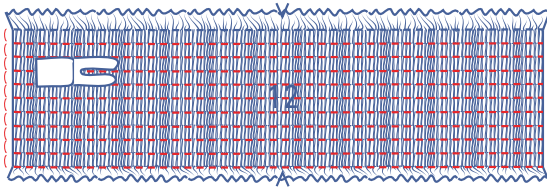

Then, sew straight lines with elastic thread parallel to the previous stitching; these should always be 1 cm apart. While stitching, tug the fabric so that it stays flat and doesn't continue to gather. Keep going until you are approx. 1 cm from the other long end.

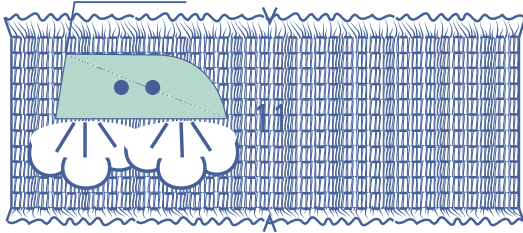

Steam your stitching.

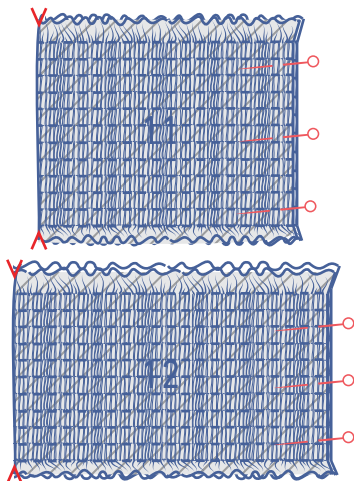
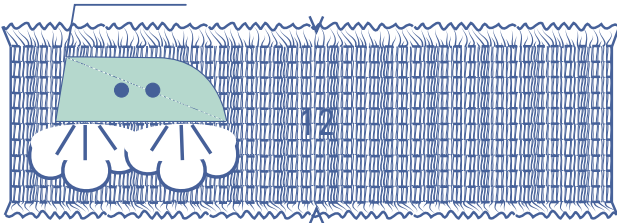

Fold both rectangles in half with the short ends together and the wrong sides of the fabric facing.

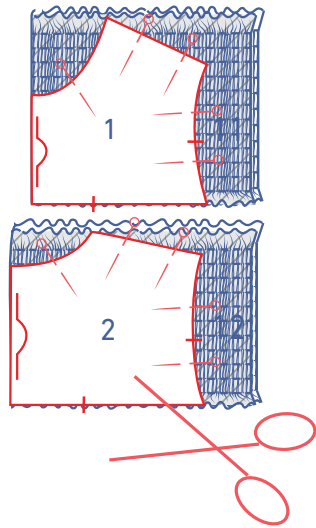

Pin the top piece front (1) and top piece back (2) to the matching smocked pieces, making sure the ends line up evenly with the fold line where indicated.

Now, cut the pieces out.

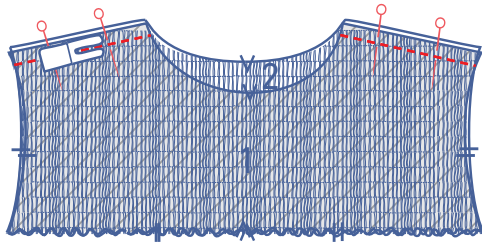

Pin and sew the shoulder seams.

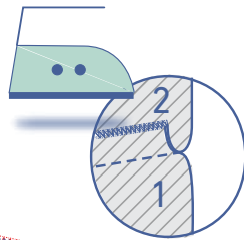

Finish the raw edges with overlock stitching and press the seam allowance towards the back.

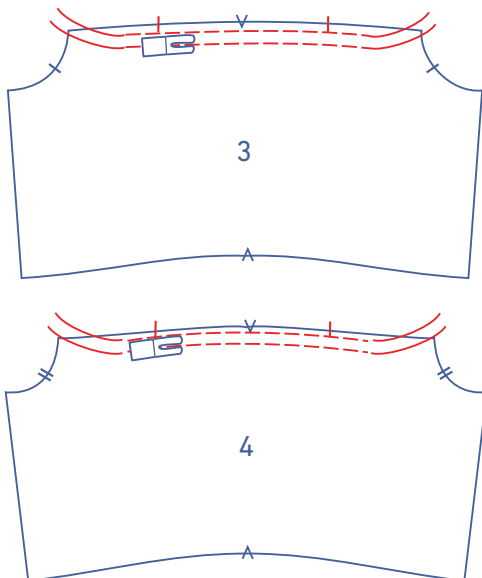
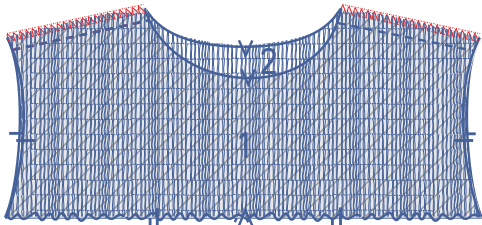

2

Sew two parallel lines of stitching at presser foot width from the top of the front (3) and back (4), using a long stitch length at a low thread tension. Sew just past the highlighted single notches. Leave a length of thread at the start and end of the stitching.

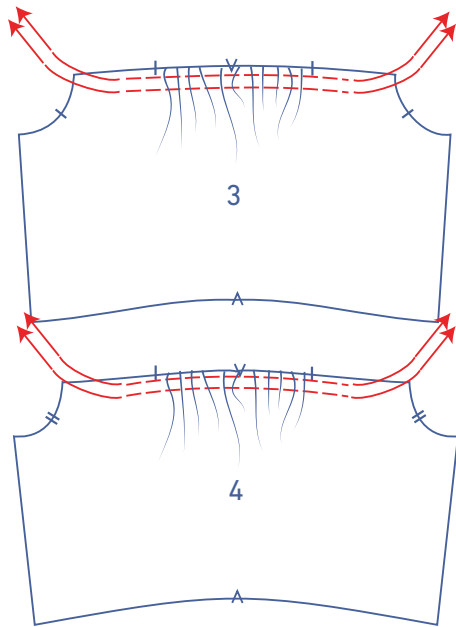

Gently tug the ends of the threads to gather the fabric.

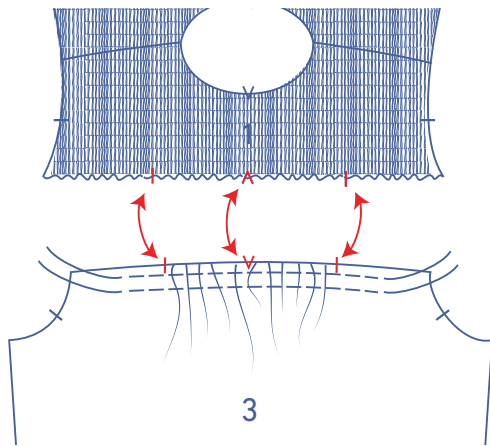

Pin the front and top piece together, matching the notches, and sew into place.

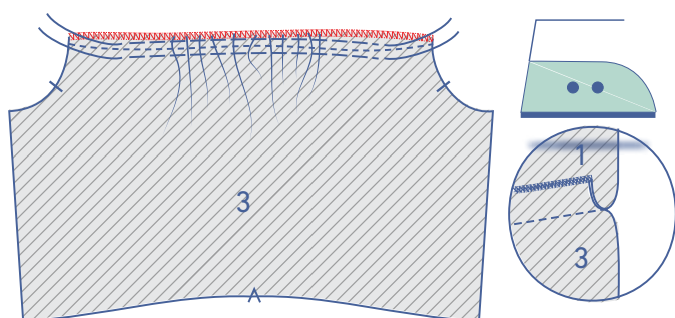
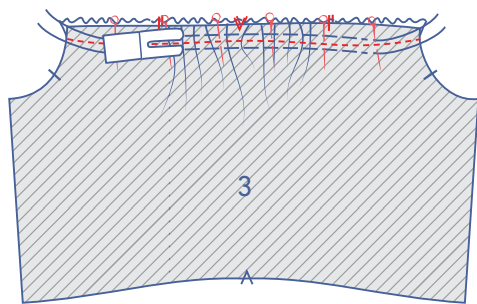

Finish the raw edges with overlock stitching. Press the seam allowance towards the top piece.

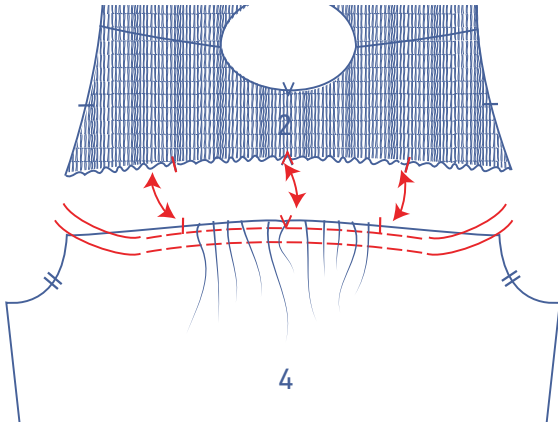

Pin the back and top piece together, matching the notches, and sew into place.

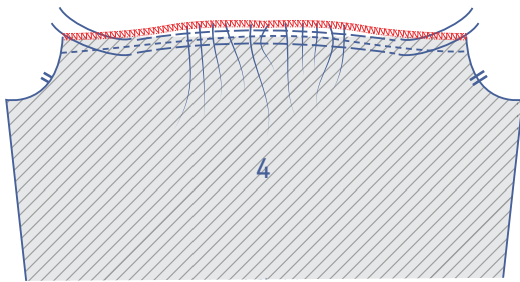
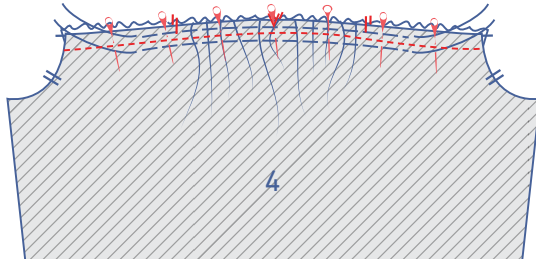

Finish the raw edges with overlock stitching and press the seam allowance towards the top piece.

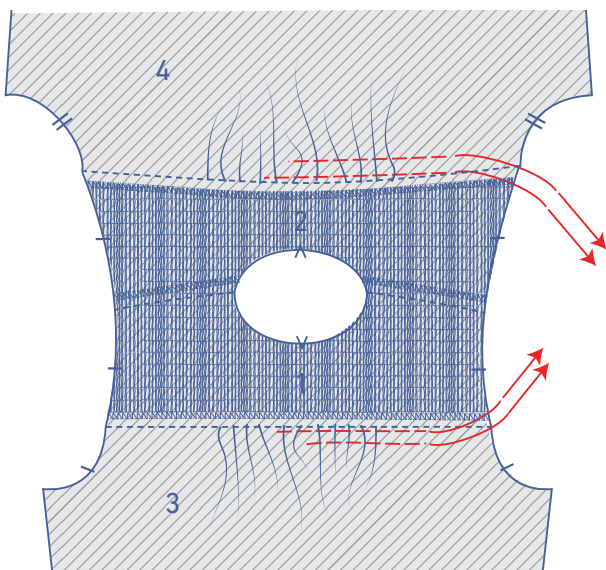
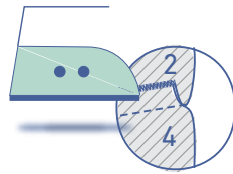

Remove the gathering threads.

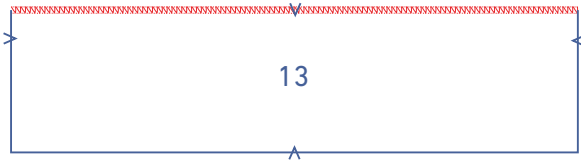

3

Finish the end of the rectangle collar (13) with overlock stitching where indicated.

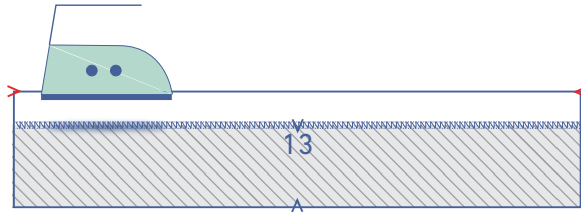

Press the top of the rectangle over at the V notches.

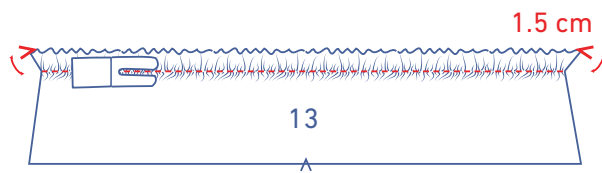

Sew a straight line parallel to the finished edge with elastic thread at 1.5 cm from the finished edge.

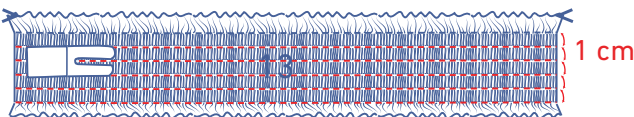

Then, sew straight lines with elastic thread parallel to the previous stitching; these should always be 1 cm apart. While stitching, tug the fabric so that it stays flat and doesn't continue to gather. Keep going until you are approx. 1 cm from the bottom.

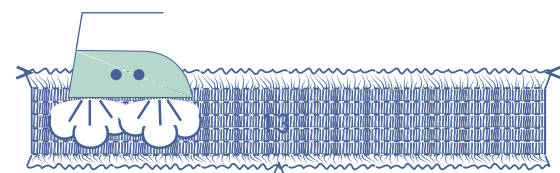
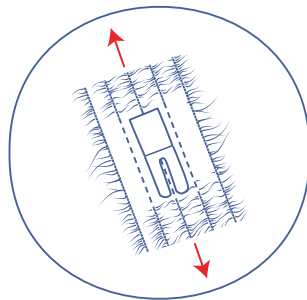

Steam your stitching.

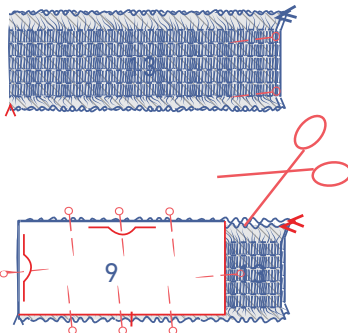

Fold the rectangle in half with the short ends together and the wrong sides of the fabric facing. Pin into place.

Pin the collar (9) paper piece to the smocked rectangle. Match the long, unnotched end of the collar to the finished top of the smocked rectangle. Cut this out.

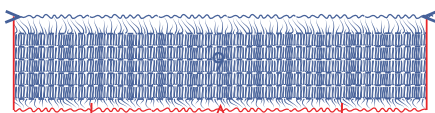

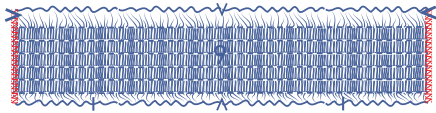

Finish the short ends of the collar with overlock stitching.

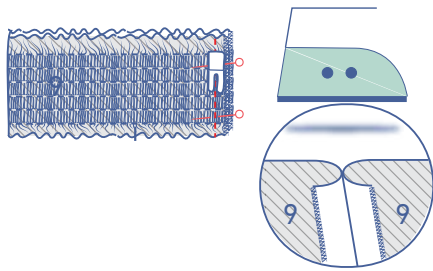

Pin and sew the CB seams together. Press the seam allowance open.

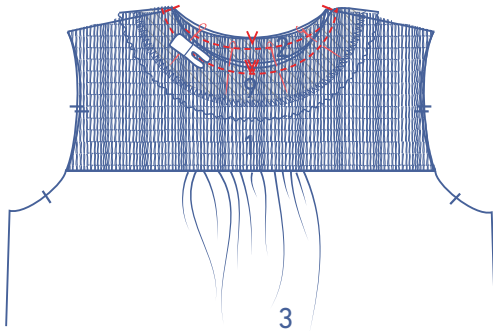

Pin and sew the collar to the top piece, matching the notches.

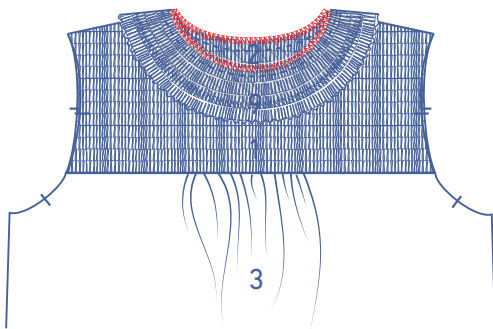

Finish the raw edges with overlock stitching.

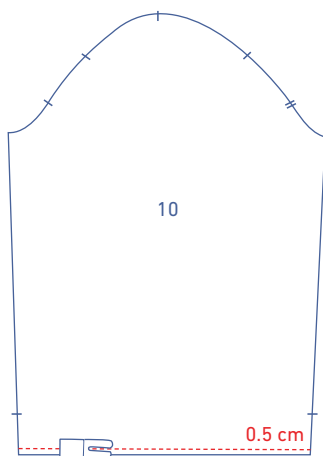

4

Finish the bottom of the sleeve (10) as follows: sew at 0.5 cm from the raw edge.

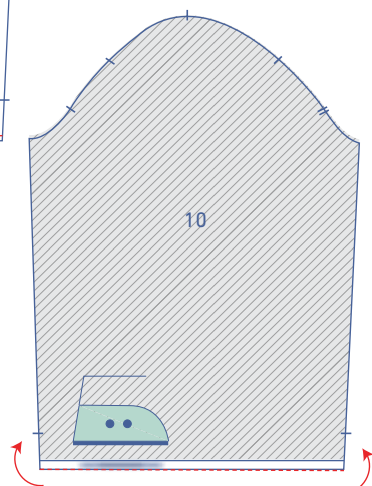

Press the raw edge towards the wrong side along your previous stitching.

Fold over again and sew into place right next to the edge.

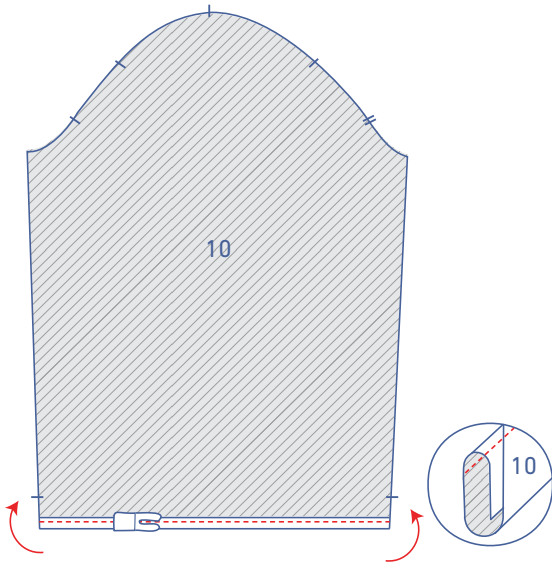

With elastic thread, sew a straight line between the highlighted notches, parallel to the bottom of the sleeve.

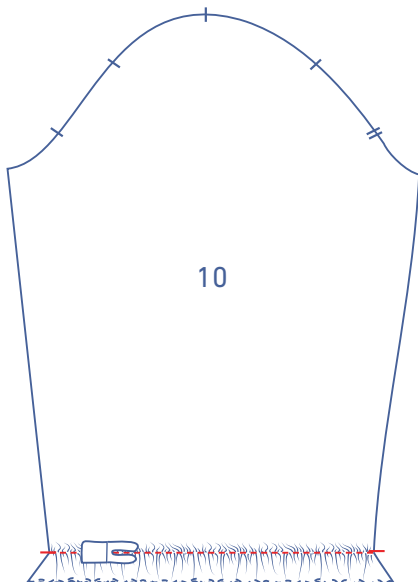

Then, sew however many straight lines you'd like with elastic thread parallel to the previous stitching, always at 1 cm apart. While stitching, tug the fabric so that it stays flat and doesn't continue to gather.

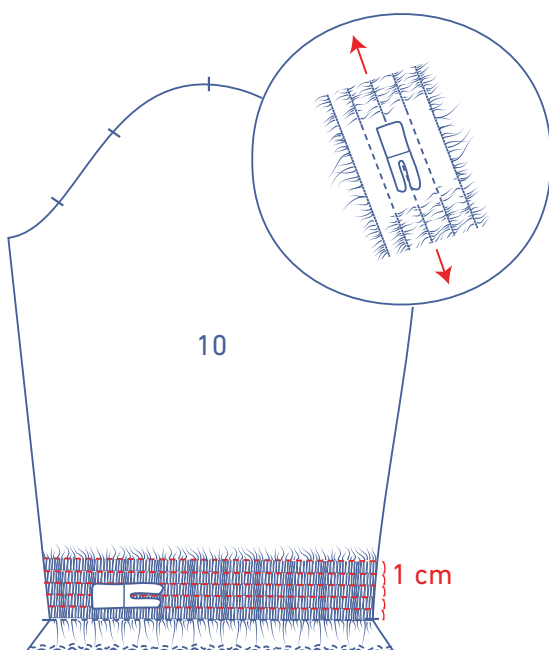

Sew two parallel lines of stitching at presser foot width from the top of the sleeve with a long stitch length at a low thread tension. Sew just past the illustrated notches. Leave a length of thread at the start and end of the stitching.

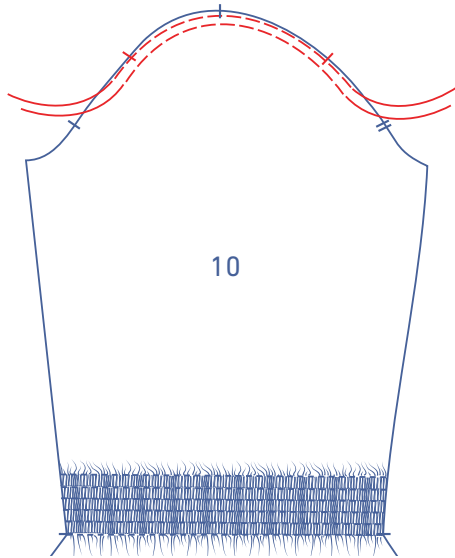

Gently tug the ends of the threads to gather the fabric.

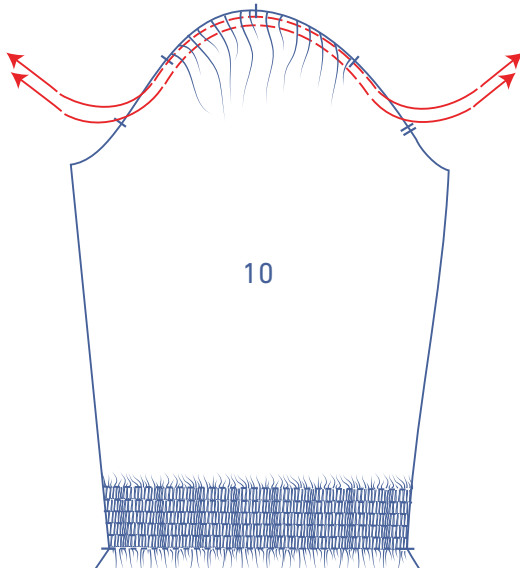

Pin and sew the top of the sleeve (= sleeve cap) to the armhole, matching the notches. The single notch marks the front, while the double notch marks the back. The single notch at the top should line up evenly with the shoulder seam. Distribute the sleeve gathers until the notches match.

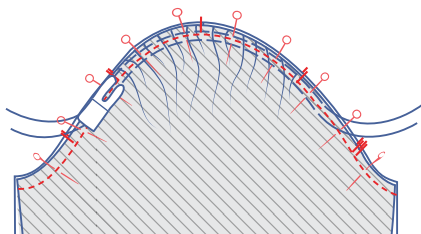
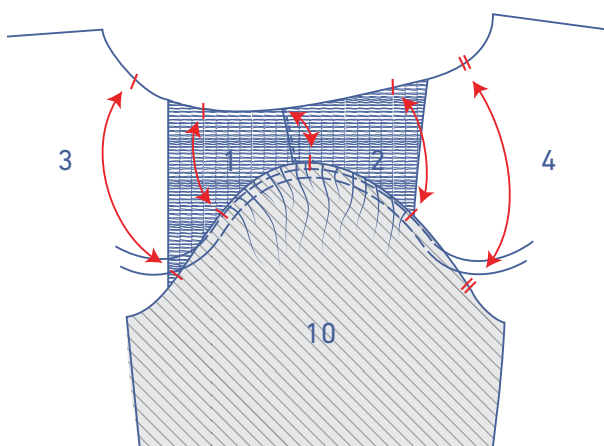

Finish the raw edges with overlock stitching.

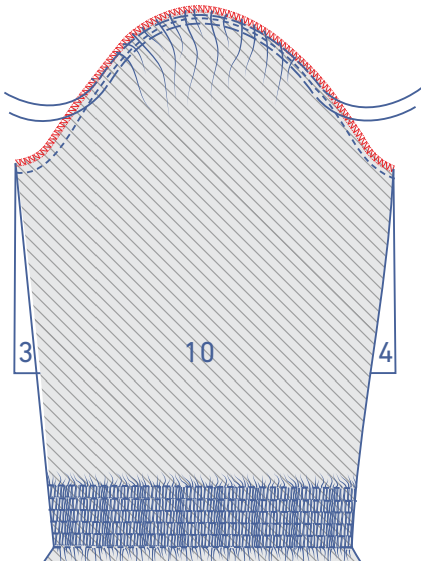

Remove the gathering threads.

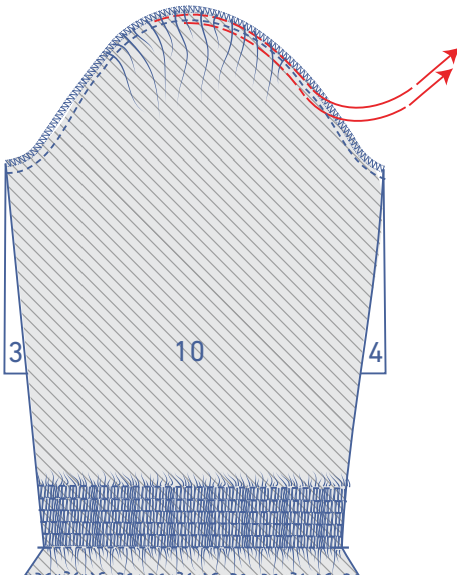

5

Pin and sew the side and underarm seams.

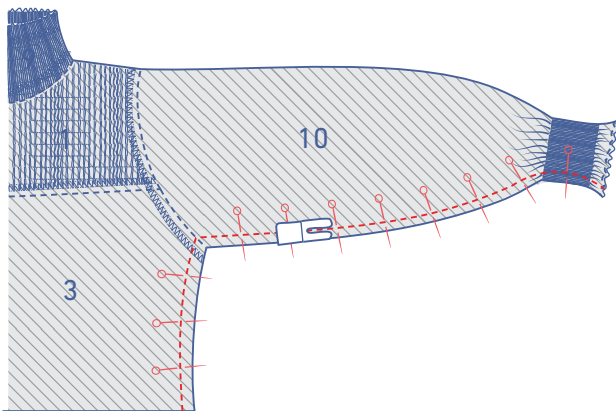

Finish the raw edges with overlock stitching.

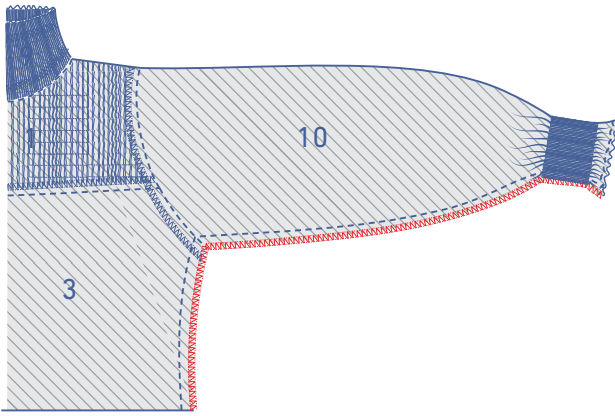

Overlock the bottom of the bodice to finish.

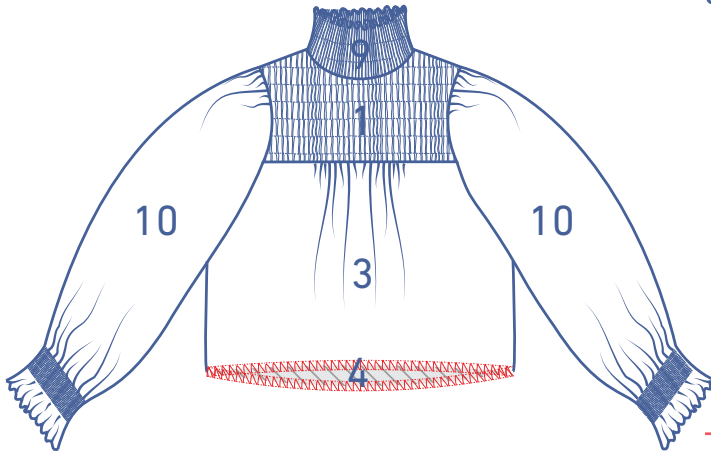

6

Finish the ends of the skirt front (5) and skirt back (6) pieces and the bottom skirt front (7) and bottom skirt back (8) pieces with overlocking where indicated.

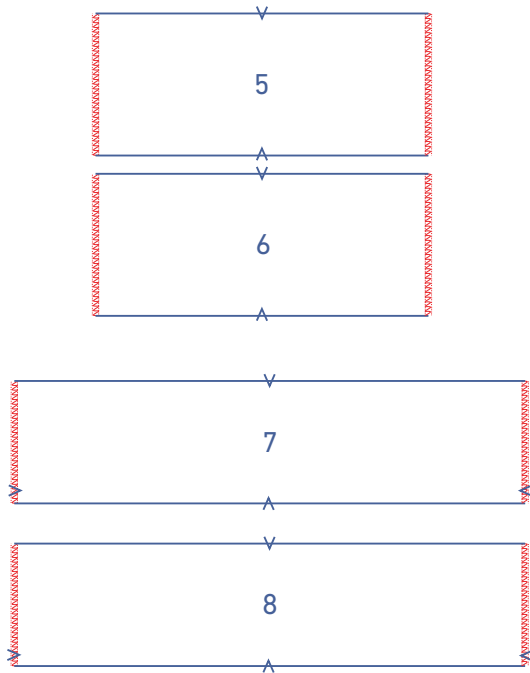

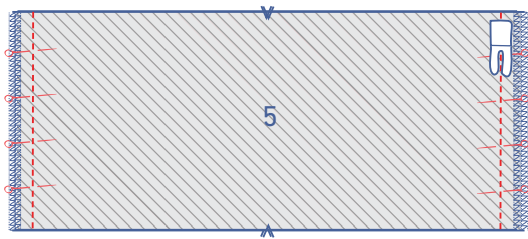

Pin and sew the skirt pieces together and press the seam allowances open.



Pin and sew the bottom skirt pieces together and press the seam allowances open.

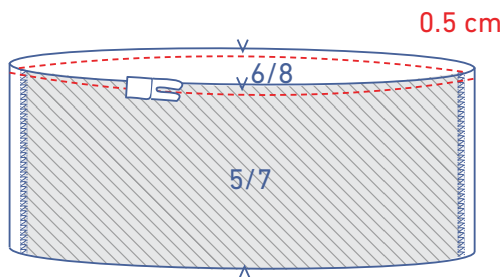

Finish the top of the skirt and bottom skirt piece as follows: sew at 0.5 cm from the raw edge.

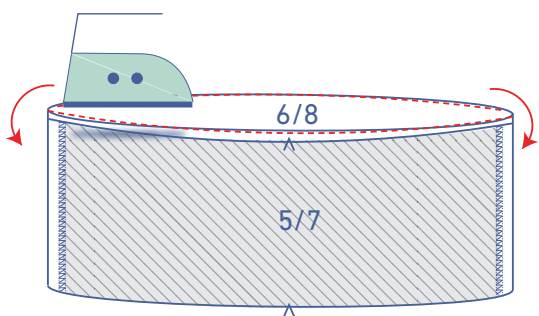

Press the raw edge towards the wrong side along your previous stitching.

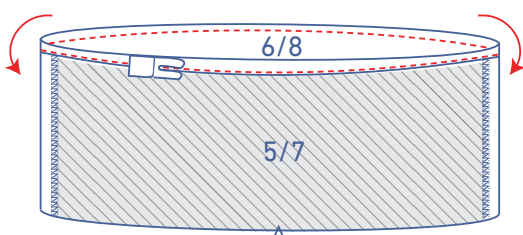

Fold over again and sew into place right next to the edge.

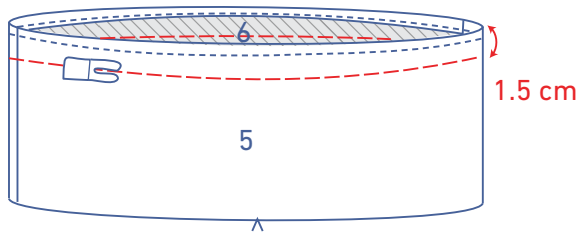

7

Sew a line of tacking at 1.5 cm from the skirt's finished edge using a long stitch at a low thread tension.

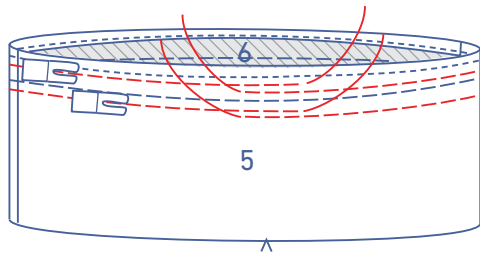

Use a long stitch at a low thread tension to sew two parallel lines of stitching on either side of the tacking. Leave a length of thread at the start and end of the stitching.

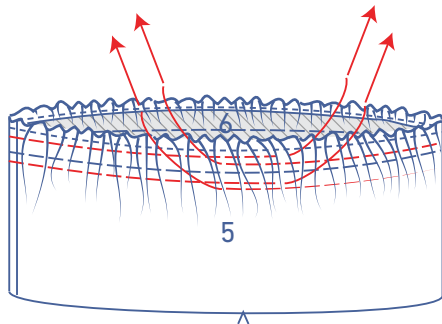

Gently tug the ends of the threads to gather the fabric.

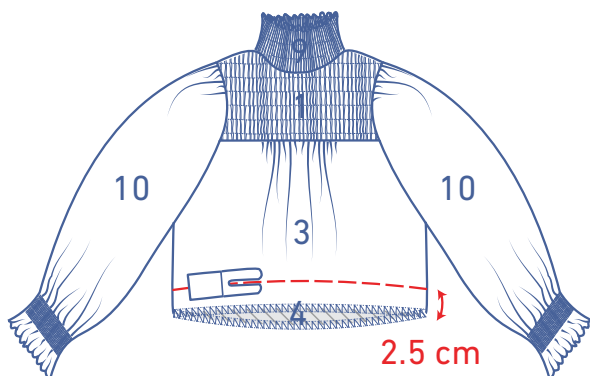

Sew a line of tacking at 2.5 cm from the raw edge of the bodice using a long stitch at a low thread tension.

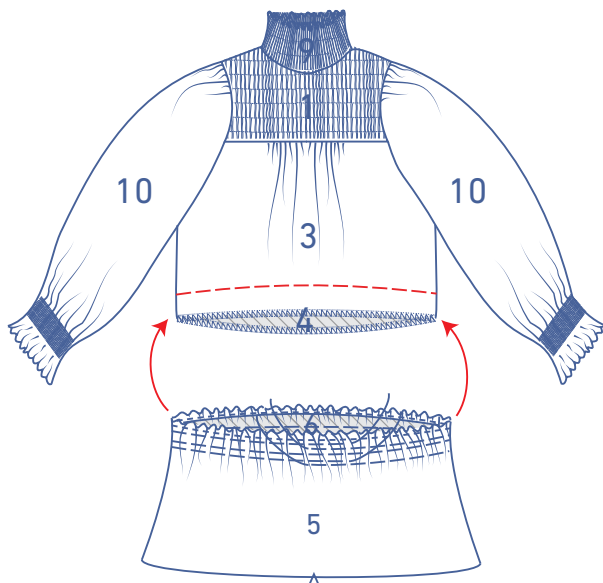

Distribute the skirt's gathers until its side seams match those of the bodice.

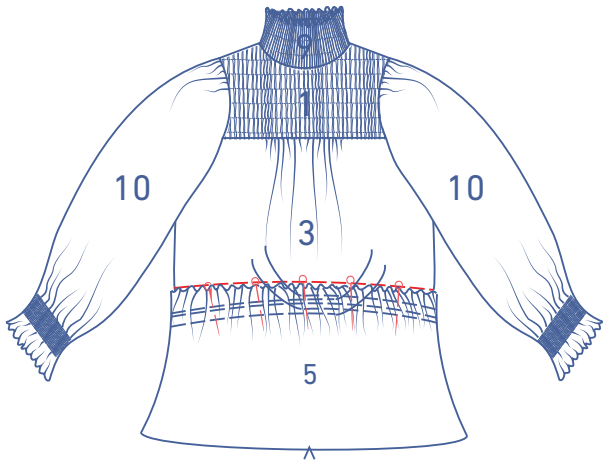

Pin the skirt to the bodice, matching the skirt's finished end to the bodice's tacking.

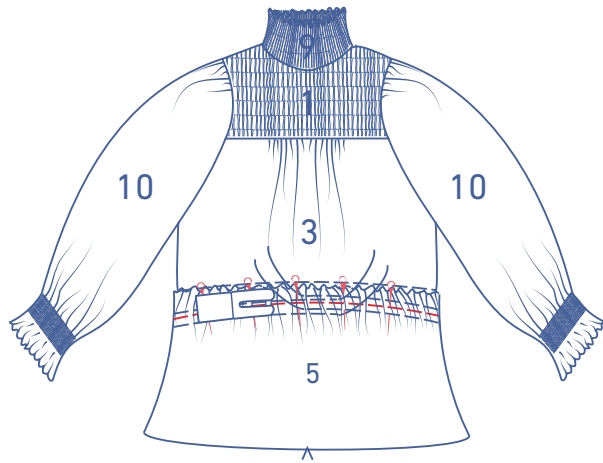

Sew the skirt to the bodice along the skirt's tacking.

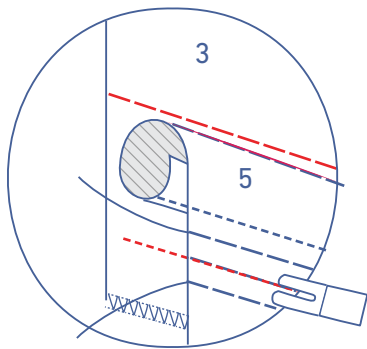

Remove the tacking and gathering threads.

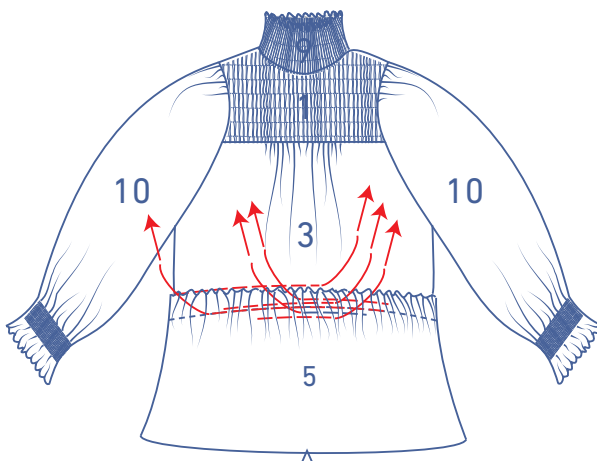

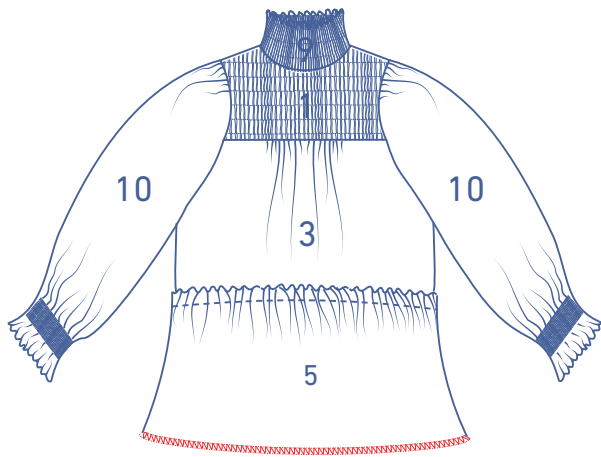

Overlock the bottom of the skirt to finish.

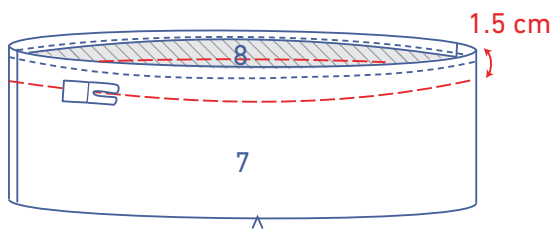

8

Sew a line of tacking at 1.5 cm from the bottom skirt piece's finished edge using a long stitch at a low thread tension.

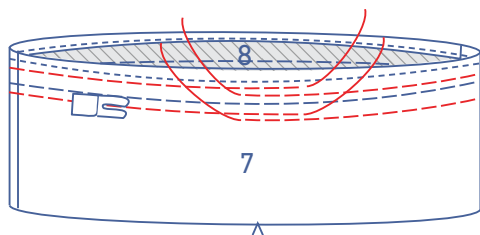

Use a long stitch at a low thread tension to sew two parallel lines of stitching to either side of the tacking. Leave a length of thread at the start and end of the stitching.

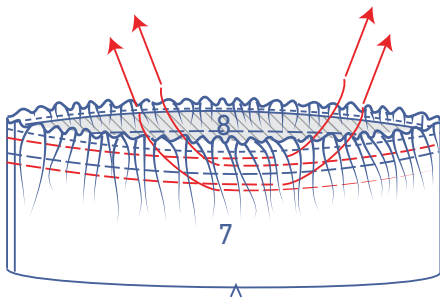

Gently tug the ends of the threads to gather the fabric.

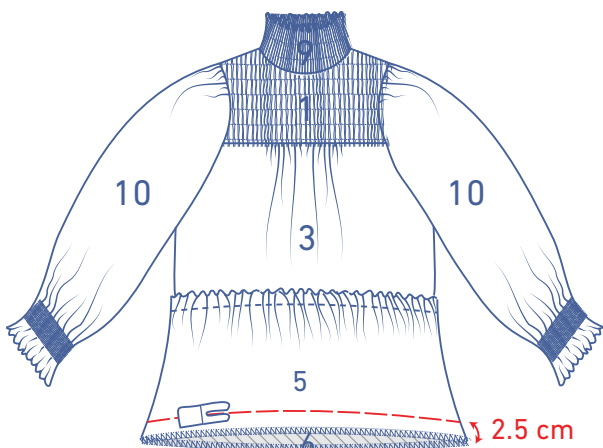

Sew a line of tacking at 2.5 cm from the skirt's raw edge using a long stitch at a low thread tension.

Distribute the bottom skirt piece's gathers until its side seams match those of the skirt.

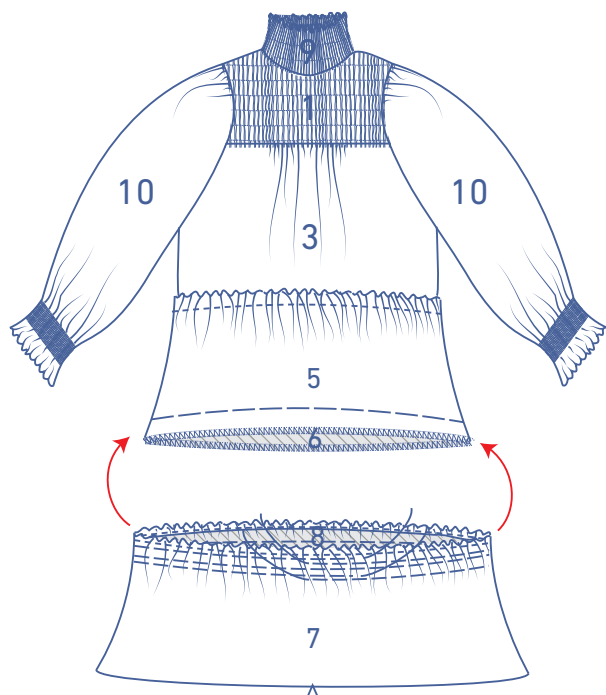

Pin the bottom skirt piece to the skirt, matching the bottom skirt piece's finished end to the skirt's tacking.

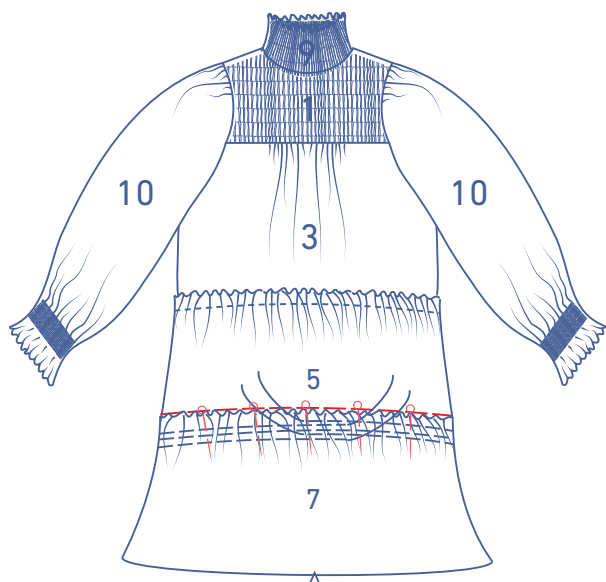

Sew the bottom skirt piece and skirt together along the bottom skirt piece's special tacking.

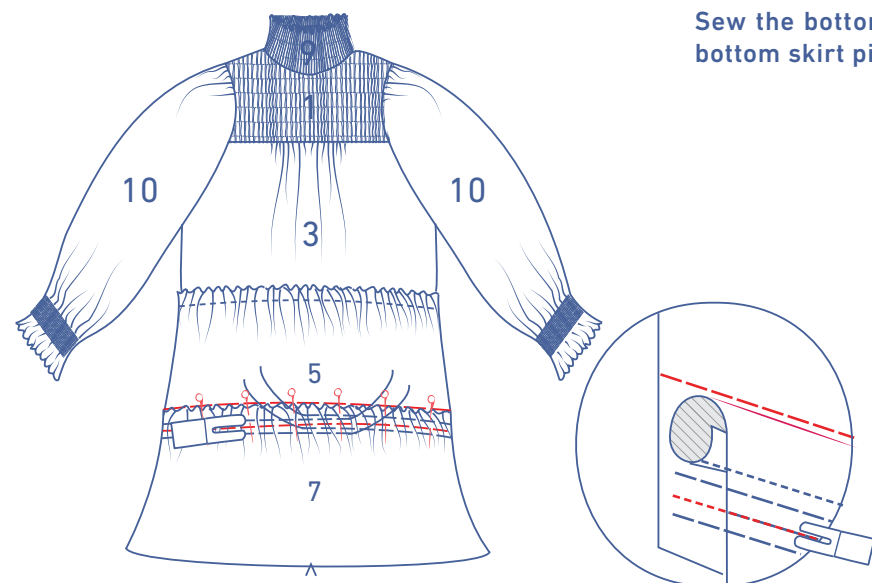

Then remove the tacking and gathering threads.

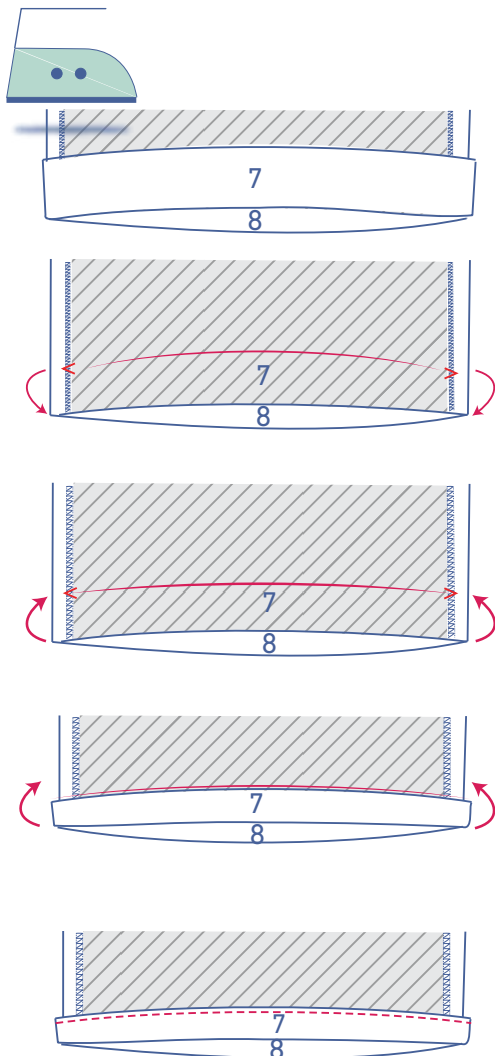
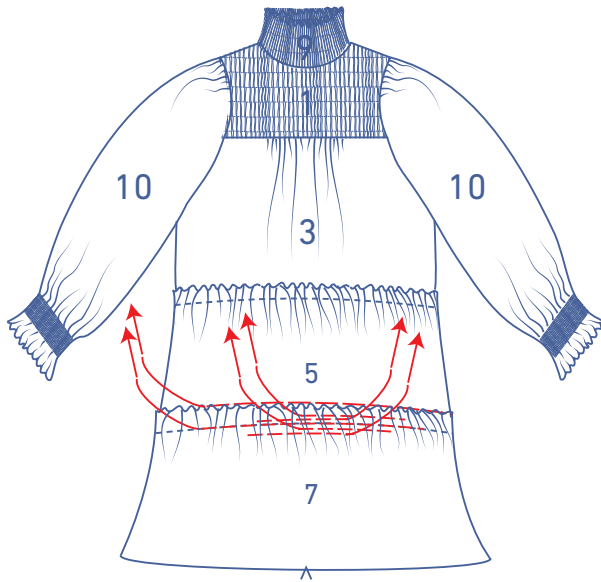

9

Press the hem allowance up at the V notches and then open back out.

Fold the raw edge to the pressed fold line and then fold again.

Edgestitch into place.