

Elora by Fibre ⚡ood



Elora by Fibre ood

***✂✂



XS - XXXL

Elora is a bit nostalgic but still totally today – especially in a daring print or bold stripe. Unicolour is also great, especially in a trendy earth tone, sky blue, or vanilla. This graceful A-line dress is bound to capture you with its charm – with or without a belt. Elora has a U-neck, balloon raglan sleeves, ruffles and gathers, and a generous topstitched hem. And lucky for you – no buttons or zips! Would you prefer a romantic top? Go for it!

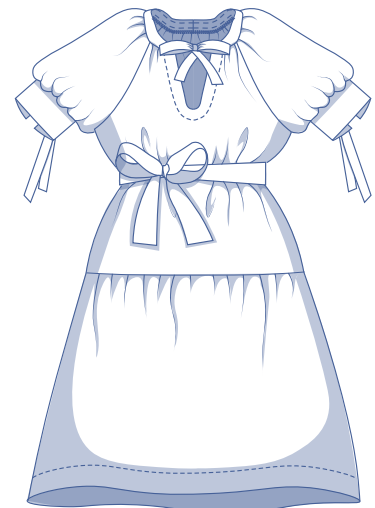
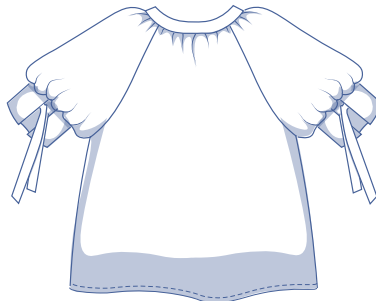
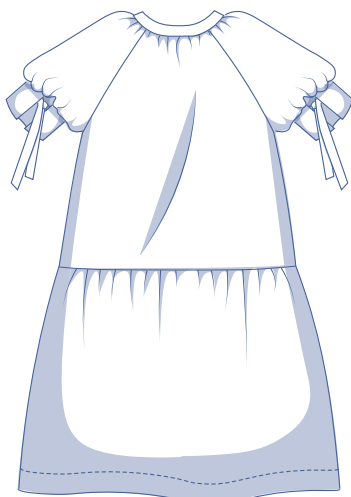
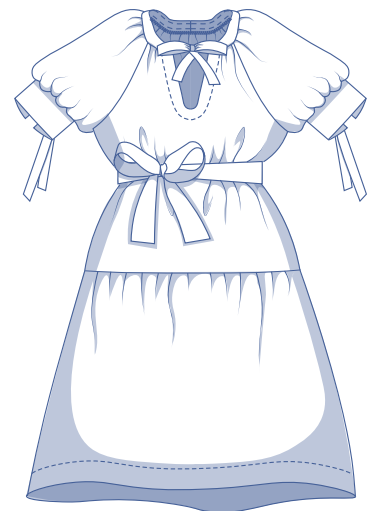
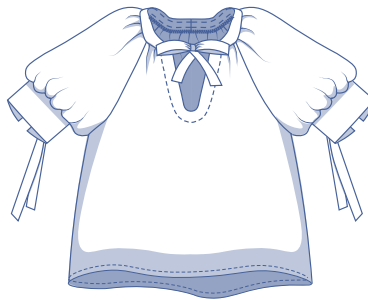
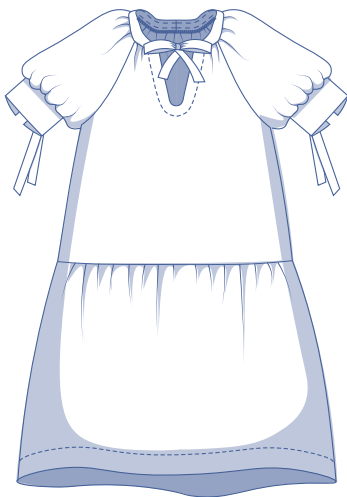

size chart (in cm)

size	XS		S		M		L		XL		XXL		XXXL		
	4	6	8	10	12	14	16	18	20	22	24	26	28	30	32
body height	160	164	166	167	168	169	170	171	172	172	172	172	172	172	172
B (bust)	76	80	84	88	92	96	100	104	110	116	122	128	134	140	146

Choose your size based on your **bust measurement**. Pick the size that is the best match for your bust.

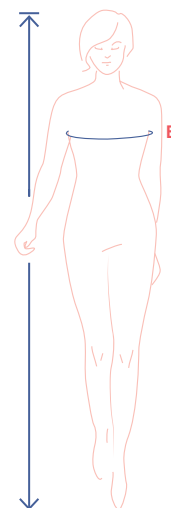

pattern measurements (in cm)

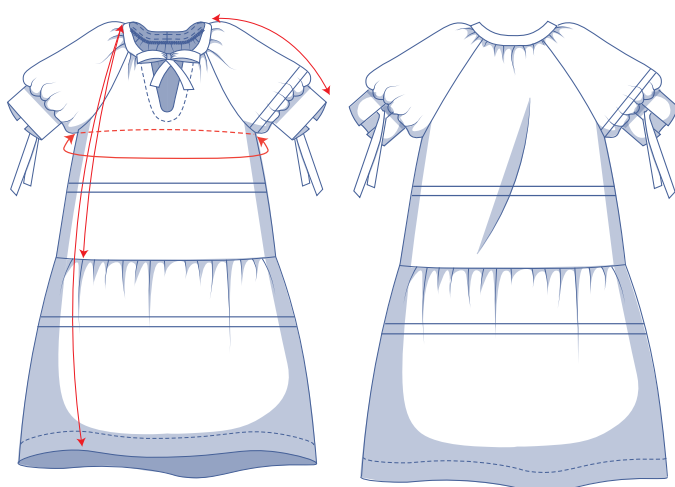

== shorten or lengthen the pattern here

This chart's measurements are the pattern measurements based on the fabric type and serve as a reference. Ease has been added to the width measurements (in addition to the exact body measurements) for a more comfortable fit. Elora is designed to have a **loose cut**. Depending on the preferred cut, you could go a size smaller or larger than the recommended size.

size	XS	S	M	L	XL	XXL	XXXL
length	123	124	125	126.75	129.25	131.5	132.5
top length	56.25	58	59.5	61	63.25	65	67
sleeve length*	41.5	42.5	43.75	45.25	48.25	50.25	52.5
bust	96.75	104.75	112.75	120.75	131	143	155

* Including the shoulder length and cuff.

Compare the stated lengths to the measured or desired lengths. **Lengthen** or **shorten** the dress and/or the sleeves by cutting the pattern pieces at the indicated double lines. Then either increase the distance between the cut pieces by the desired amount (to lengthen) or overlap the pieces (to shorten). Make sure that the CF and CB lines and the side seams are always straight.



IMPORTANT

Adjust the amount of fabric to be used based on these alterations.

notions



- Thread
- Iron-on interfacing: max. 45 cm
- Fabric: see table

dress fabric		XS	S	M	L	XL	XXL	XXXL
fabric width 110 cm	cm	315	330	335	395	425	510	550
fabric width 140 cm	cm	305	310	310	315	340	345	350

The corresponding fabric layout can be found on page 6 of these sewing instructions.

top fabric		XS	S	M	L	XL	XXL	XXXL
fabric width 110 cm	cm	155	170	175	225	250	265	275
fabric width 140 cm	cm	150	155	160	170	185	190	200

fabric advice



Good options for Elora include a range of cottons, such as voile, poplin, Broderie Anglaise, chambray, etc. However, more drapery fabrics, such as silk (satin), lyocell, crepe, and double gauze also work well.

Proud to be #Sewista

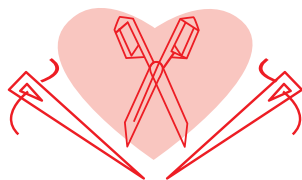

pattern pieces & seam allowances (in cm)

To sew the garment as described in the instructions, draw the illustrated seam allowances around the paper pattern pieces before cutting them out. If you are using a PDF pattern, the pattern can be printed with or without seam allowance.

To find out more, watch the [video](#).

- | | |
|---|---------------------------------------|
| 1. front: 1x on fabric fold | 8. cuff: 2x |
| 2. skirt front: 1x on fabric fold | 9. neckline facing: 1x on fabric fold |
| 3. back: 1x on fabric fold | 10. sleeve binding: 2x |
| 4. skirt back: 1x on fabric fold | 11. tie: 6x |
| 5. sleeve: 2x | 12. pocket: 4x |
| 6. neck binding front: 2x | 13. belt loops: 1x |
| 7. neck binding back: 1x on fabric fold | 14. belt: 2x |

NOTE

To make the Elora top add 1,5 cm hem allowance to pattern pieces 1 and 3. You don't need pattern pieces 2, 4, 12, 13 and 14 and can ignore the pocket markings.

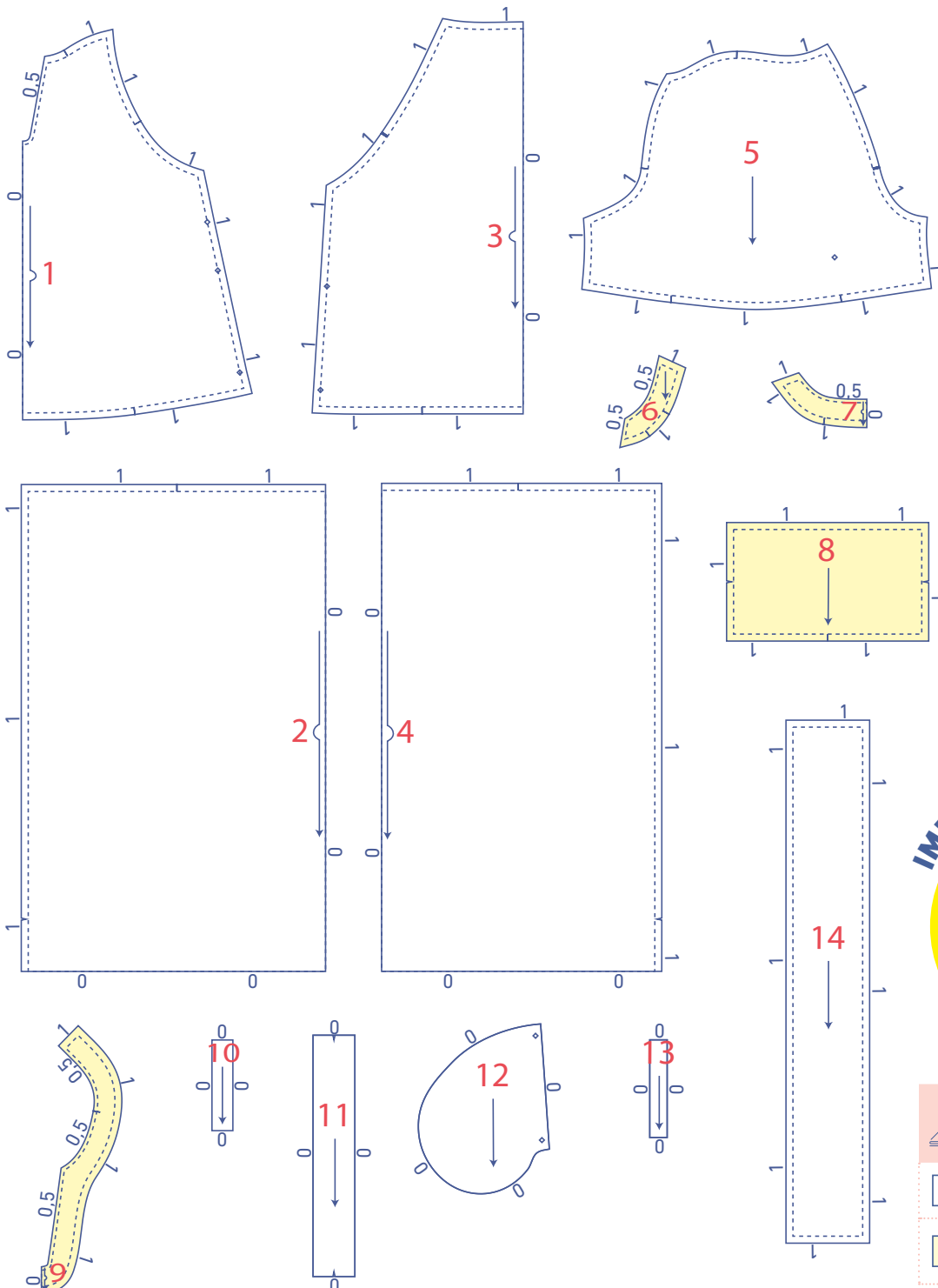

IMPORTANT

The pieces highlighted in light yellow have iron-on interfacing attached to the wrong side.

	material type
	fabric
	iron-on interfacing

fabric layout – solid fabrics
fabric width 110 cm

XS - M

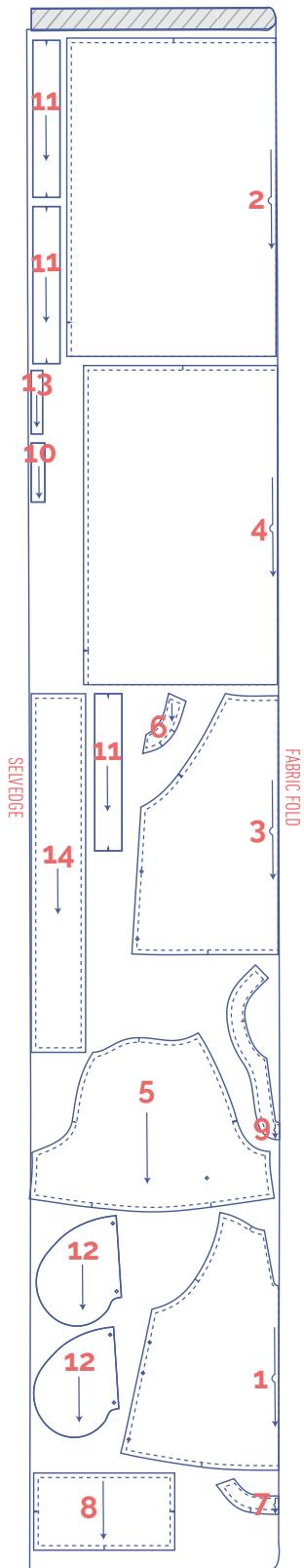

IMPORTANT

You only need pattern piece 13 once.

L - XL

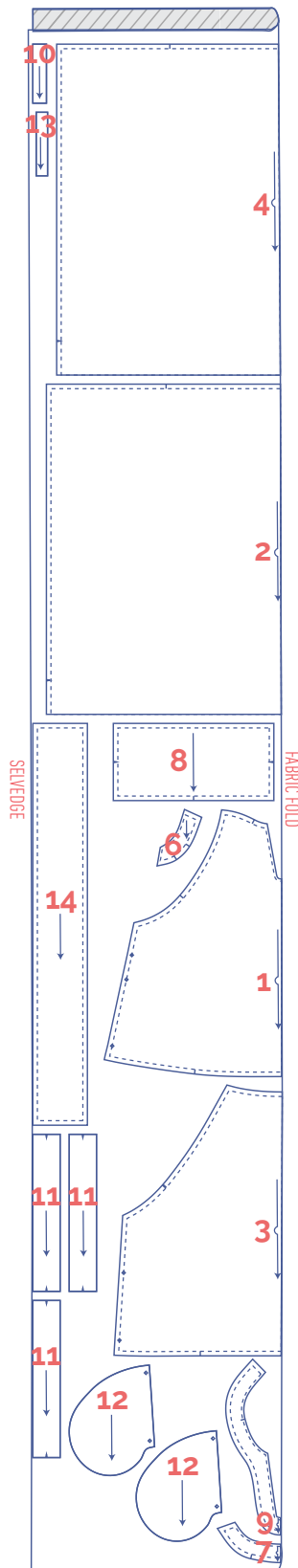

IMPORTANT

You only need pattern piece 13 once.

+

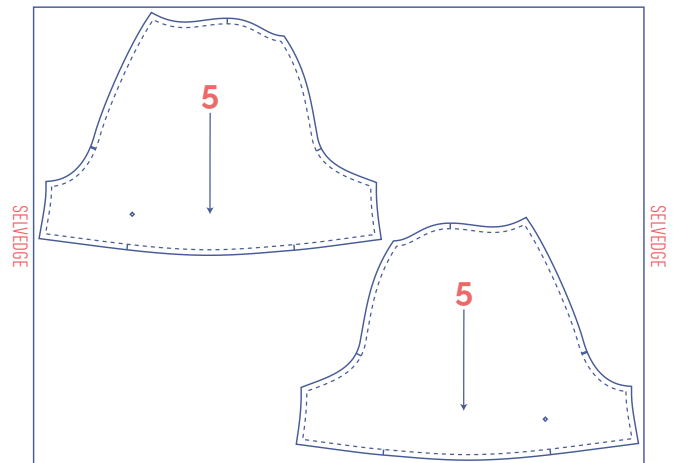

IMPORTANT

Because the fabric is opened out and single layer, be sure to cut mirror images of pattern piece 5 so you have a left and a right sleeve.

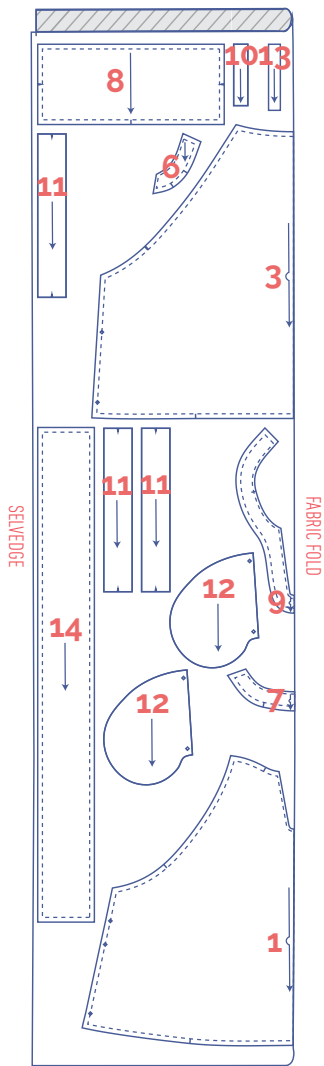

+

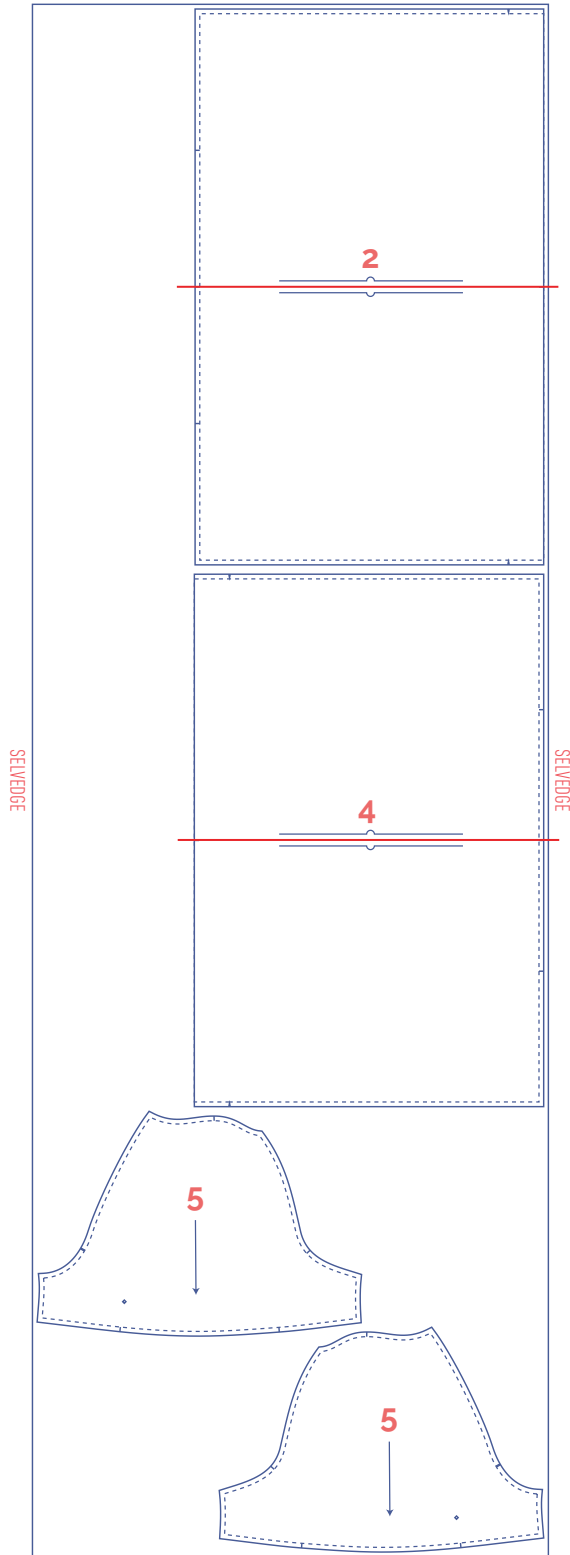

IMPORTANT

You only need pattern piece 13 once.

marking pattern pieces

	Notch the pattern paper and fabric at the following points
	single notch
	double notch
V	V notch
	Mark the following internal points with marking thread
	centre point

IMPORTANT

Because the fabric is opened out and single layer, be sure to cut mirror images of pattern piece 5 so you have a left and a right sleeve.

Pattern pieces 2 and 4 have been rotated at a 90° angle to fit the fabric width. If you are working with a directional print or napped fabric and want everything to go in the same direction, you will need extra fabric. Then instead of cutting pattern piece 2 on the fold, cut 2 mirror images and sew them together. Be sure to add 1cm seam allowance to the CB before you cut.

fabric layout – solid fabrics
fabric width 140 cm

XS - L

XL - XXXL

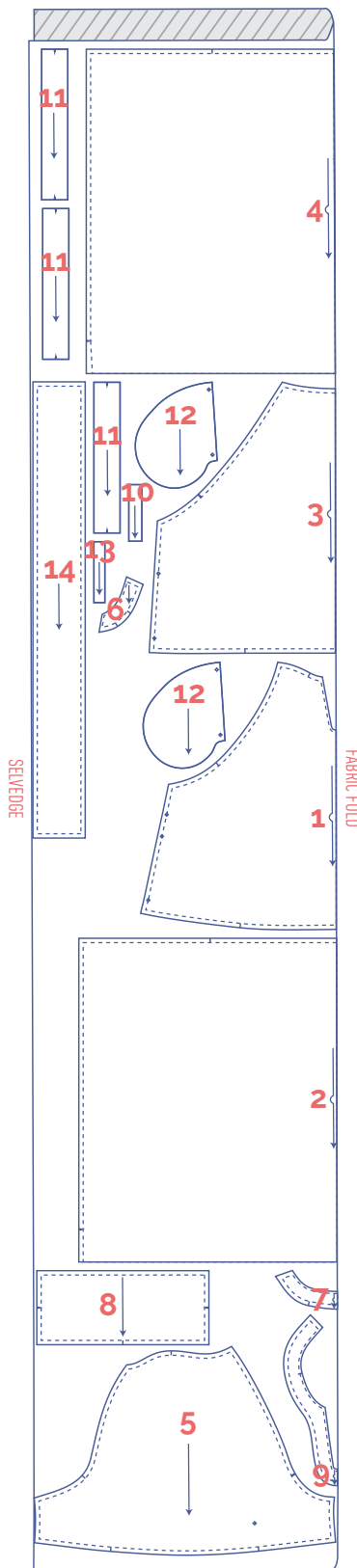
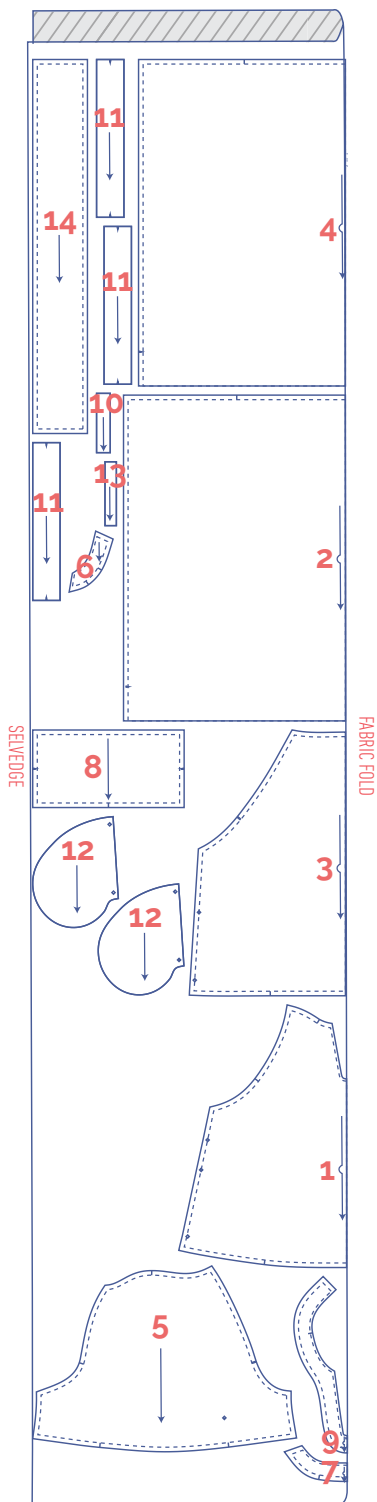







IMPORTANT

You only need pattern piece 13 once.

IMPORTANT

You only need pattern piece 13 once.

marking pattern pieces

	Notch the pattern paper and fabric at the following points
	single notch
	double notch
	V notch
	Mark the following internal points with marking thread
	centre point

sewing instructions



The method used to finish the seams depends on the fabric used.
The pieces are always sewn together with the right sides of the fabric facing, unless stated otherwise.



F front

B back

CF centre front

CB centre back

 right side

 wrong side

 iron-on interfacing

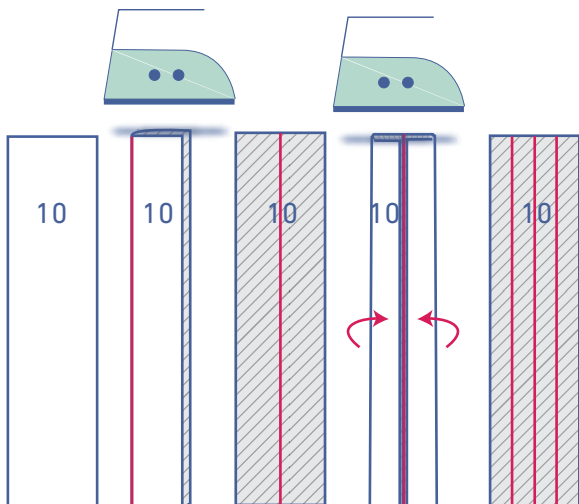
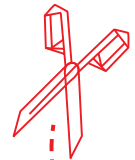

1

Press the sleeve binding (10) as follows:

- First, press the sleeve binding in half with the long ends together and the wrong sides touching to create a fold line.
- Open back out.
- Next, press the long ends so that the raw edges meet the fold line.
- Open the sleeve binding back out.

Snip into the sleeve (5) from the notch in the hem up to the marking thread.

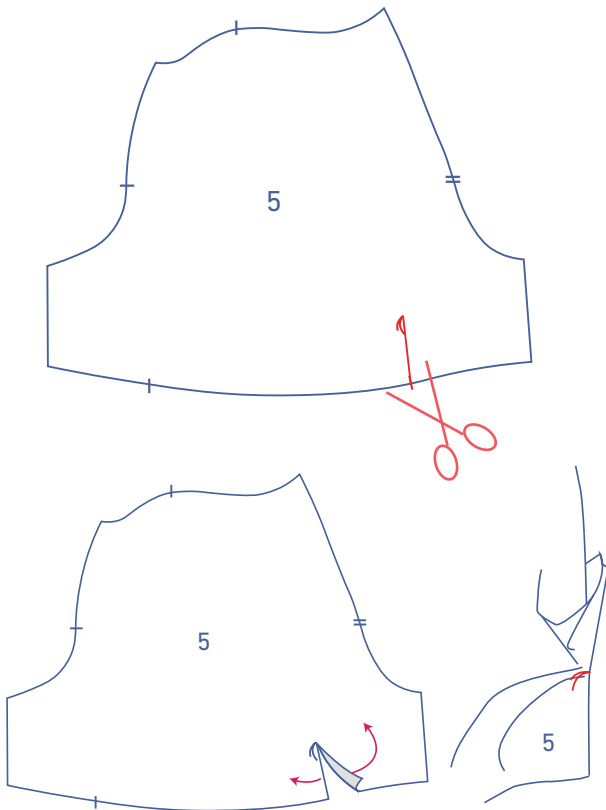

Open the sleeve split so that you end up with a single straight line.

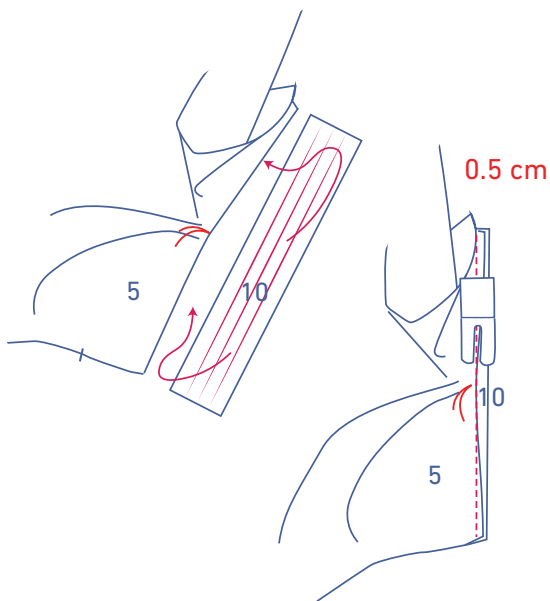

Slide the sleeve binding under the sleeve with the right side facing up. Match one long end to the end of the sleeve split and pull the sleeve a little to the side at the marking thread. Sew into place at 0.5 cm. There should only be a few stitches at the marking thread.

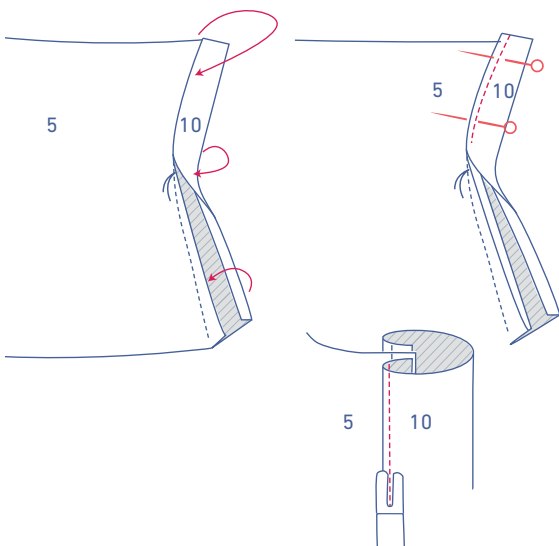

Fold the sleeve binding over towards the right side of the sleeve. Tuck under the raw edge and place the pressed fold line directly over the stitching. Sew into place right next to the edge.

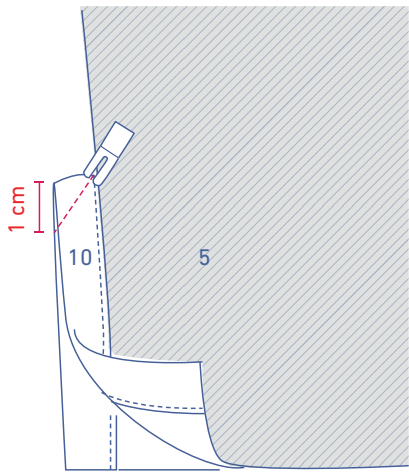

Fold the sleeve in half crosswise, with the right sides touching. Sew the top of the sleeve binding together at an angle.

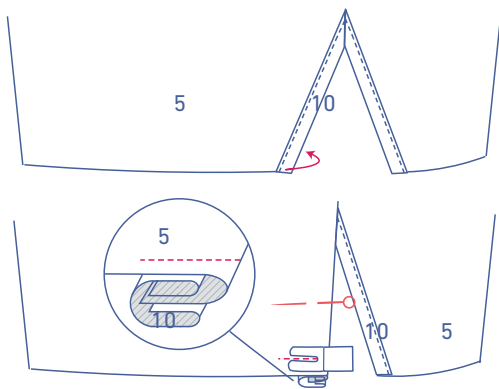

Fold the sleeve binding at the front of the sleeve (at on the widest end of the sleeve hem) towards the wrong side of the sleeve and sew the sleeve binding into place at presser foot width from the bottom.

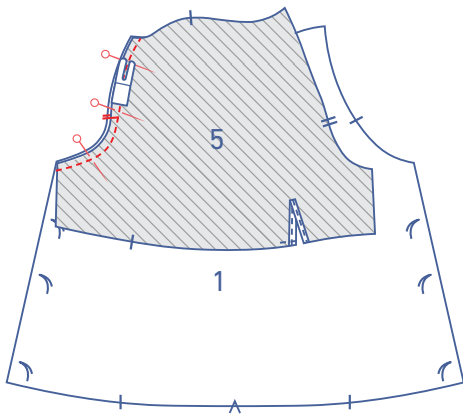

2

Pin and sew the sleeve side with a single notch to the front (1), matching the markings.

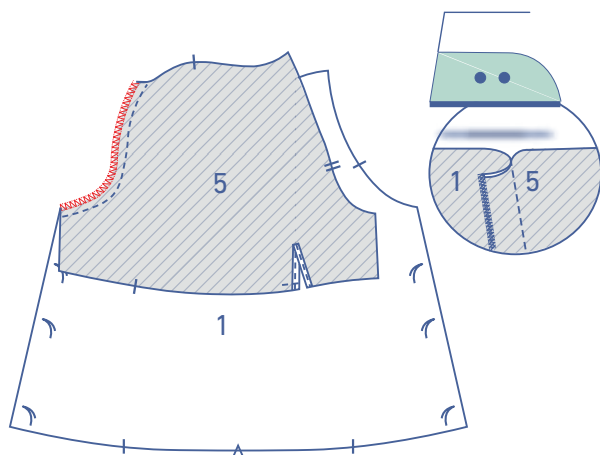

Finish the raw edges with overlocking and press the seam allowance towards the front.

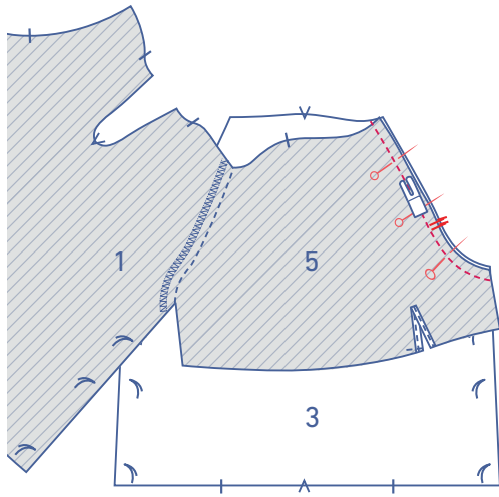

Pin and sew the double notched side of the sleeve to the back (3) with the markings matching.

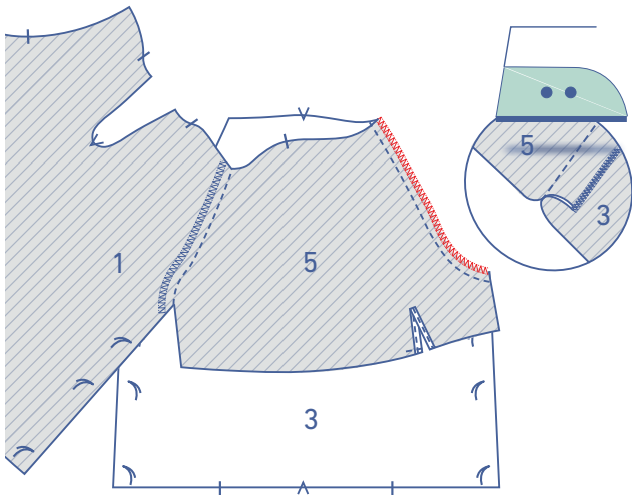

Finish the raw edges together with overlock stitching and press the seam allowance towards the back.

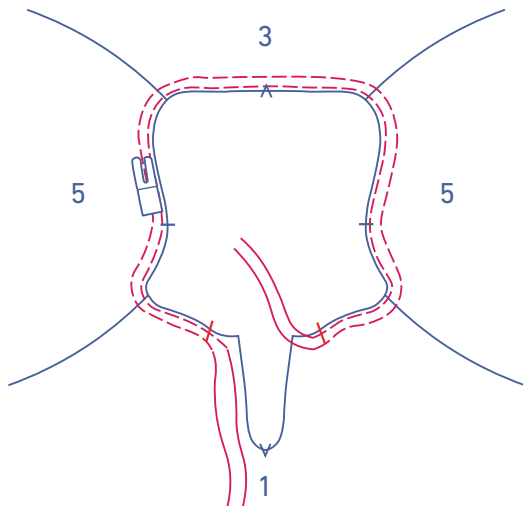

3

Sew two parallel lines at presser foot width from the neckline (front + sleeve + back) between the highlighted single notches, using a long stitch length at a low thread tension. Leave a length of thread at the start and end of the stitching.

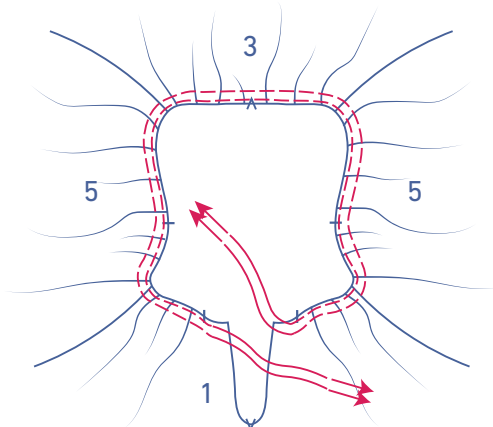

Gently tug the ends of the threads to gather the fabric.

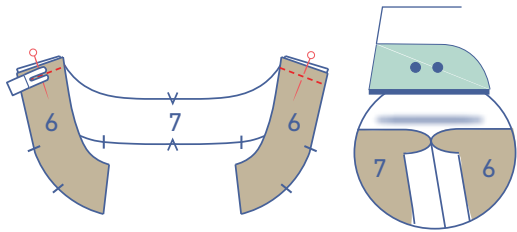

4

Pin and sew the shoulder seams of the neck binding front (6) and neck binding back (7) together. Press the seam allowance open.

Pin the neck binding to the neckline and distribute the gathers until the notches match. Make sure that the binding seams line up evenly with the single notches in the sleeve.

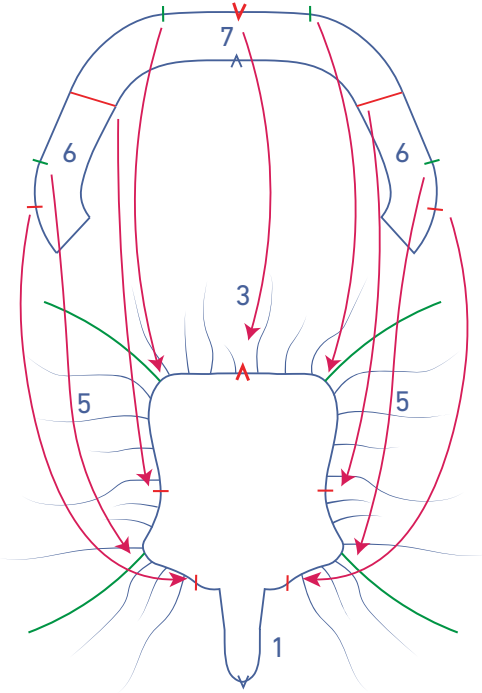

Sew into place.

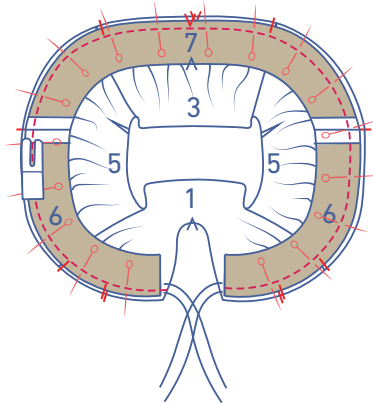

Remove the gathering threads.

Finish the raw edges with overlock stitching and press the seam allowance towards the neck binding.

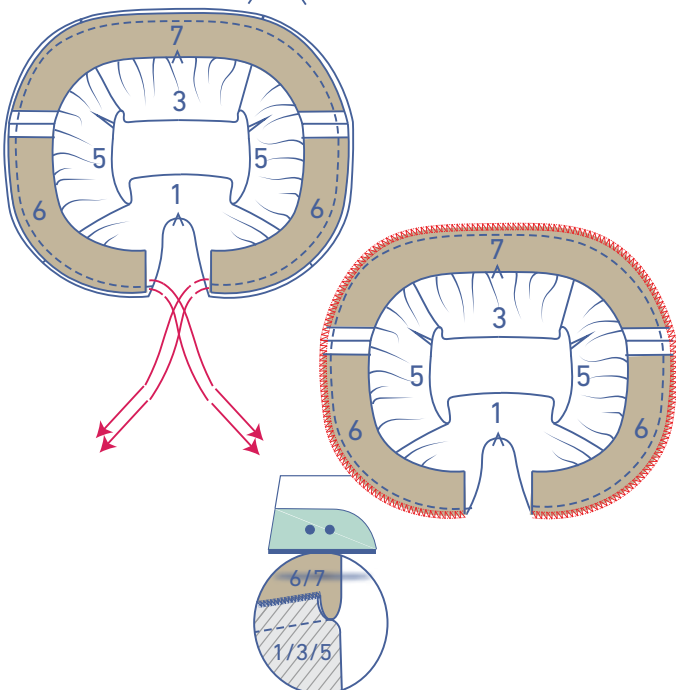



5

Fold the ties (11) in half with the long ends together and the right sides of the fabric touching.

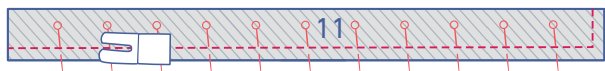

Pin and sew the edges together where indicated.

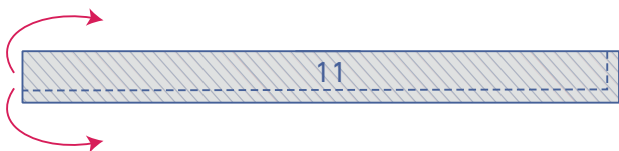

Turn the ties the right way out and press.



Pin the raw edges of two of the ties where indicated.

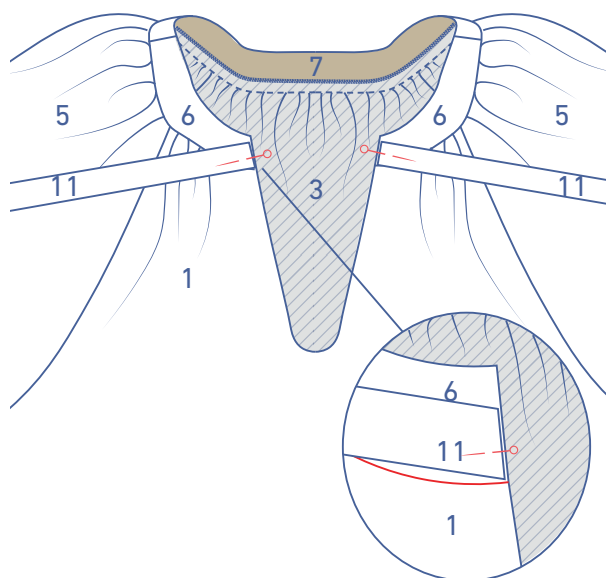

6

Finish the contours of the neckline facing (9) with overlock stitching where indicated.

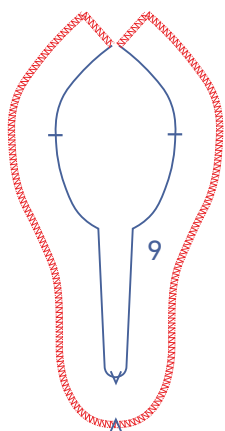

Pin and sew the CB seams together. Press the seam allowance open.

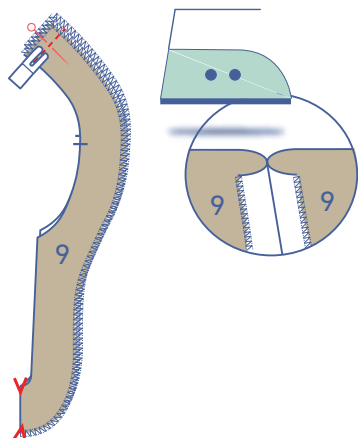

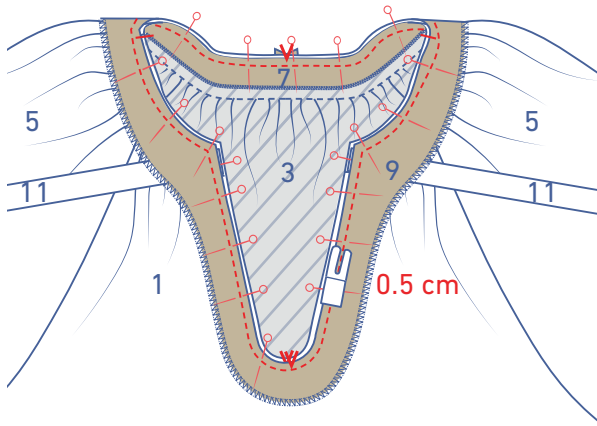

Pin the neckline facing to the garment. Sew into place at 0.5 cm from the raw edges.

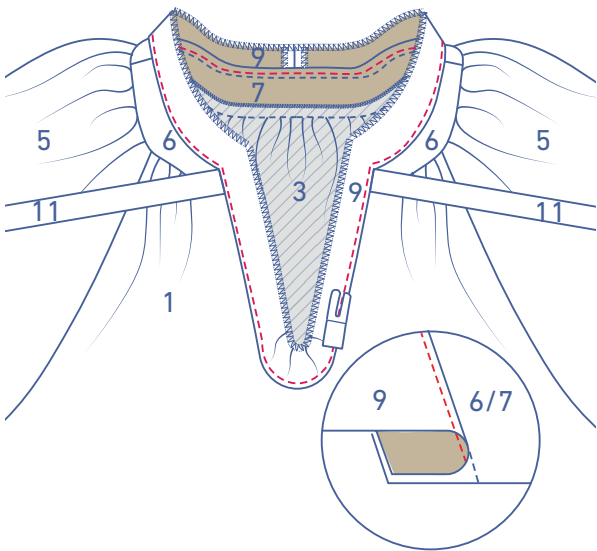

Fold the facing over and sew to the seam allowance underneath, right next to the edge.

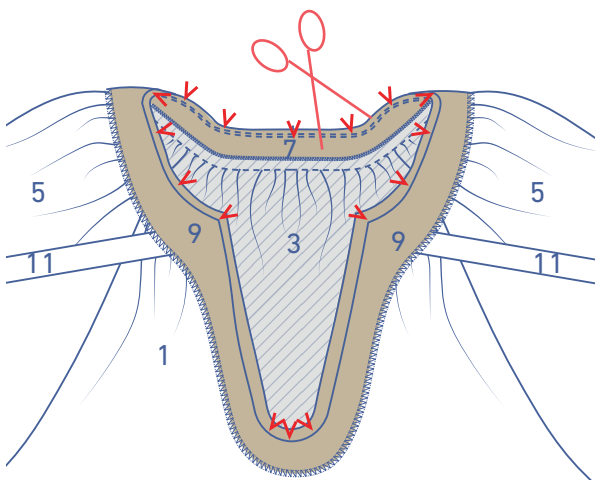

Notch the seam allowance so the facing lies flat when you turn it the right way.

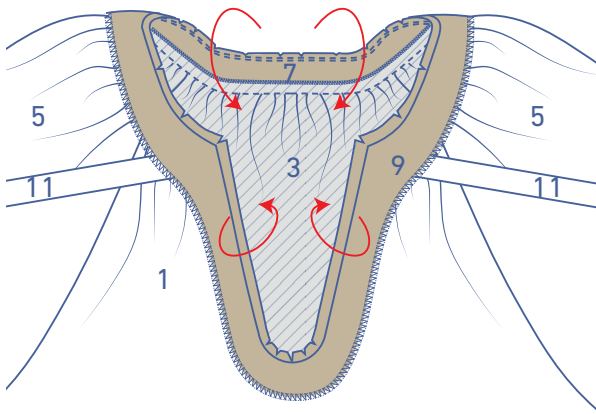

Turn the facing the right way (i.e. fold over to the wrong side).

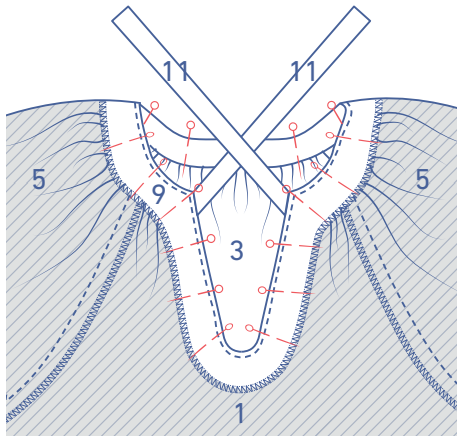

Pin into place.

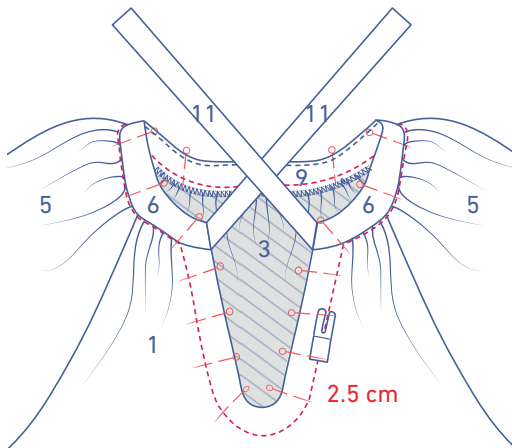

Sew the facing into place along the right side of the garment at 2.5 cm from the finished neckline. For the rest, stitch in the ditch as shown to secure the facing.

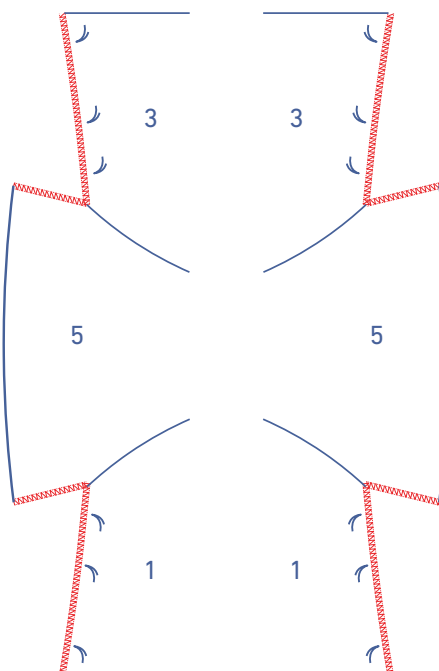

Finish the garment's raw edges where indicated with overlock stitching.

7

Finish the straight ends of the pocket (12) with overlock stitching.

Pin the straight ends of two of the four pocket pieces to the front with the marking threads matching. Sew into place between the marking threads.

Fold the pocket and seam allowance over and sew the pocket to the seam allowance underneath (= understitch).

Pin the straight ends of the two remaining pocket pieces to the back, matching the marking threads. Sew into place between the marking threads.

Fold the pocket pieces over (but do not understitch).

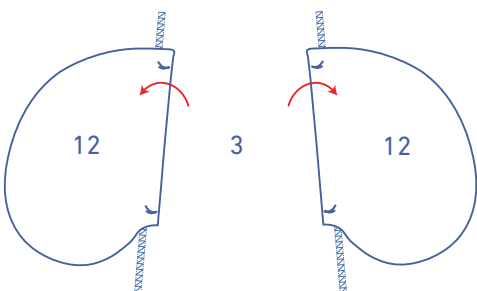
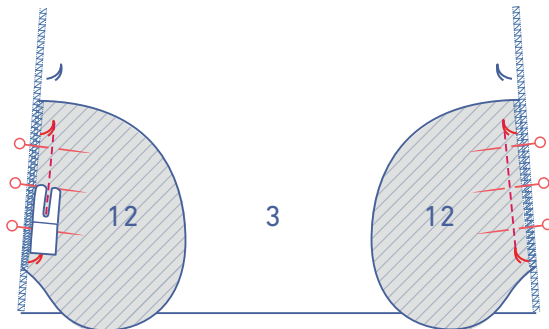
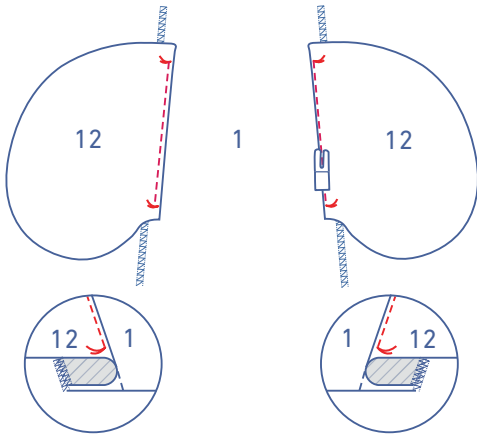
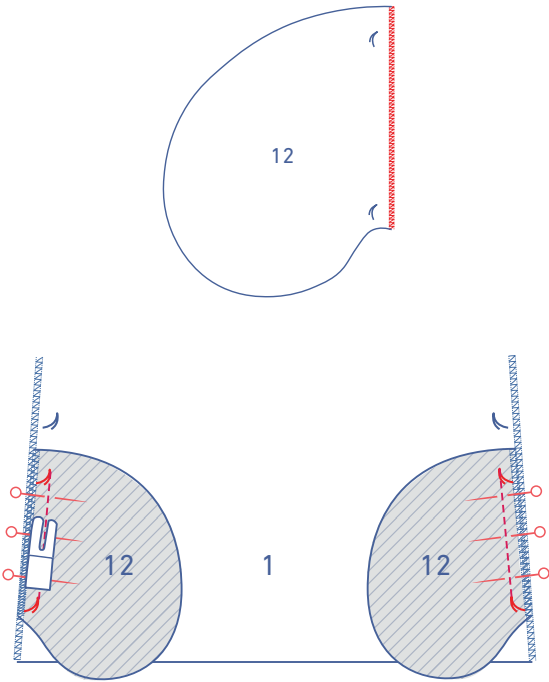

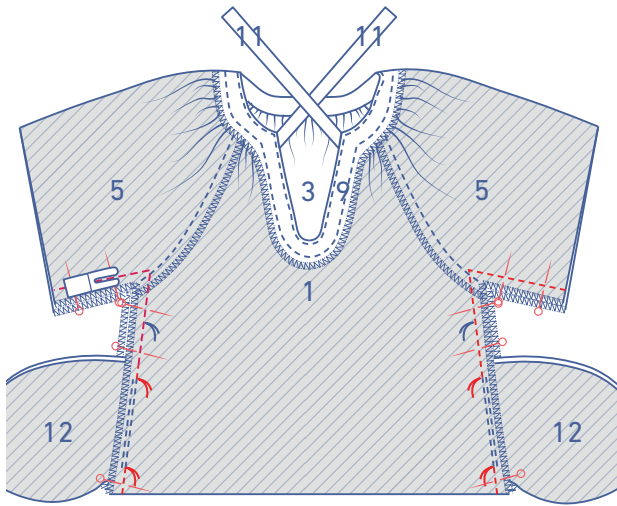

Pin and sew the side and underarm seams of the sleeve and the front and back up to the marking threads that indicate the top of the pocket opening. Continue sewing from the next marking thread to the bottom.

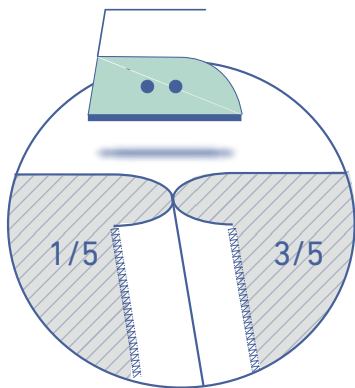

Press the seam allowance open.

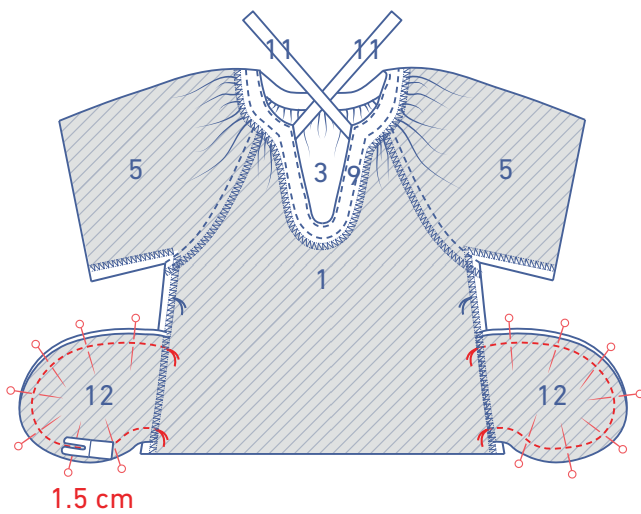

Pin and sew the contours of the pocket pieces together at 1.5 cm from the raw edges.

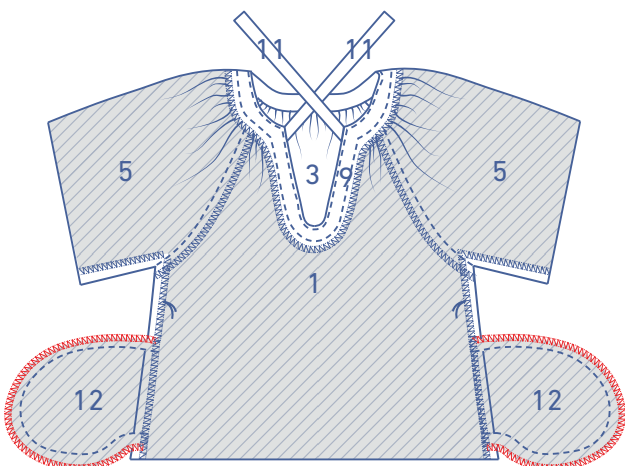

Then, finish the raw edges with overlock stitching.

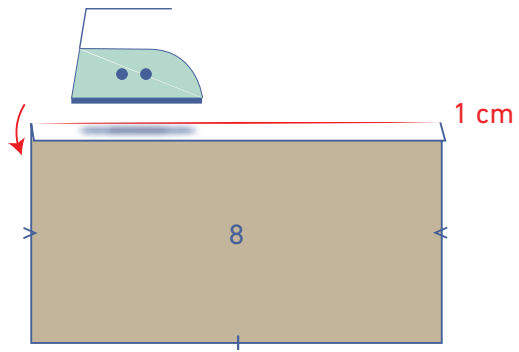

8

Press 1 cm of the cuff (8) edge over to the wrong side where indicated.

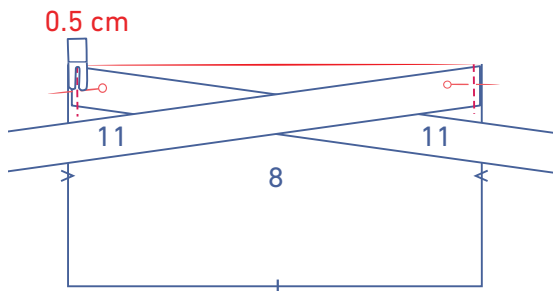

Turn the cuff over so the right side is facing up. Pin and sew the raw edge of each tie where indicated at 0.5 cm from the raw edge of the cuff.

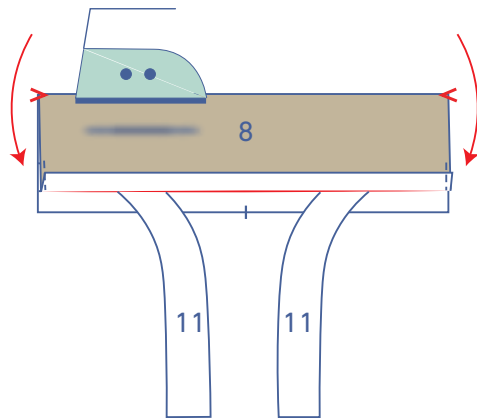

Fold the cuff in half at the V notches with the right sides of the fabric facing each other.

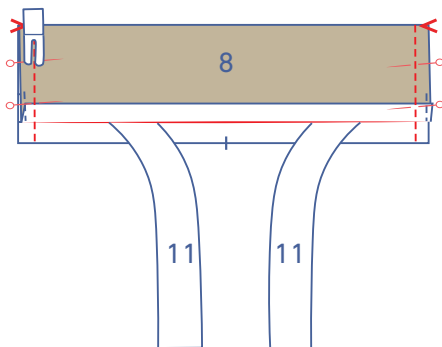

Pin and sew the short ends.

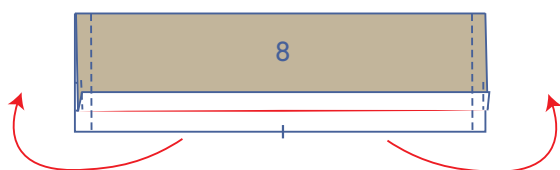

Turn the cuff the right way out.



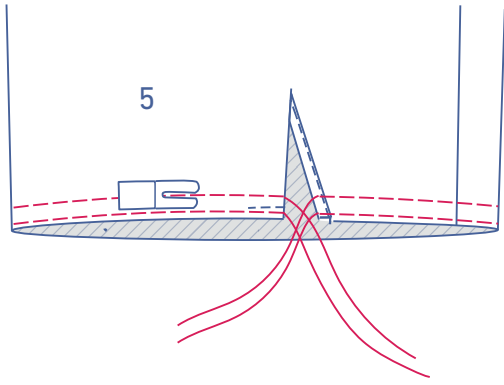

Sew 2 parallel lines of stitching to the bottom of the sleeve using a long stitch length at a low thread tension.

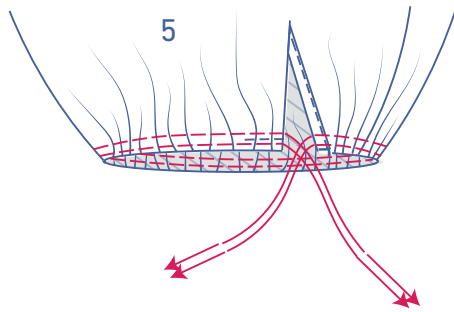

Then, gently tug the gathering threads to gather the fabric.

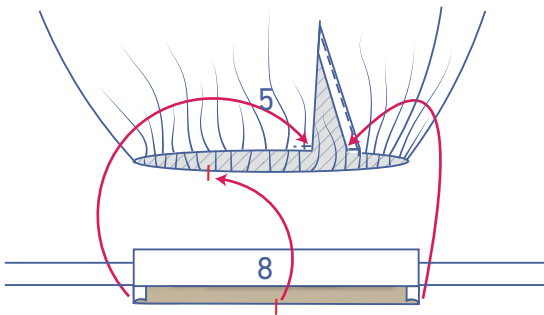

Pin the unpressed raw edge of the cuff to the bottom of the sleeve along the inside (= the wrong side), matching the markings. Distribute the gathers until the notches match .

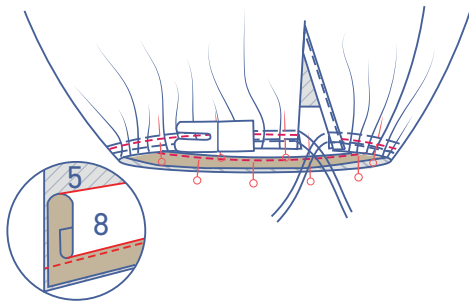

Sew into place.

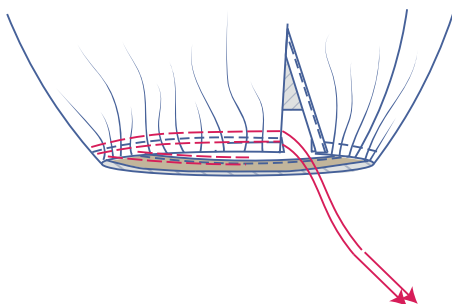

Remove the gathering threads.

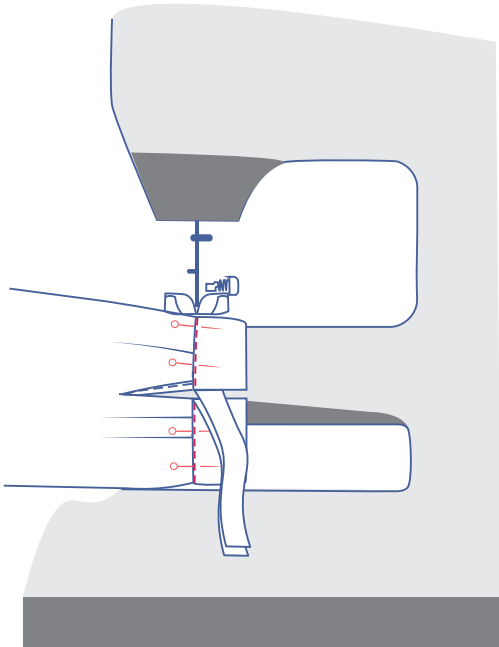

Fold the cuff over to the right side of the sleeve and place the pressed edge directly over the previous stitching. Edgestitch into place.

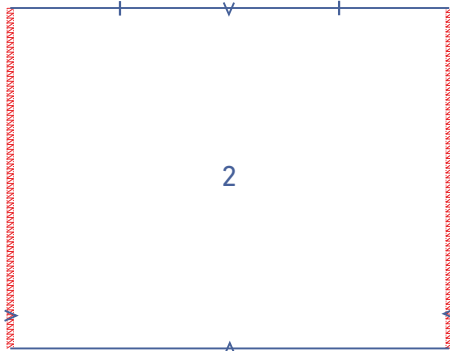

9

Finish the side seams of the skirt front (2) and skirt back (4) with overlock stitching.

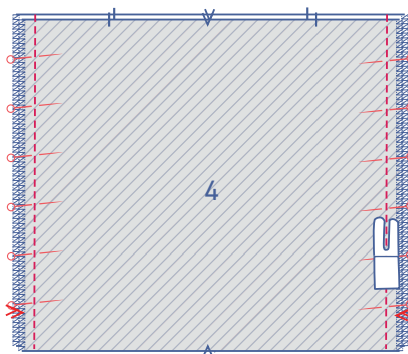
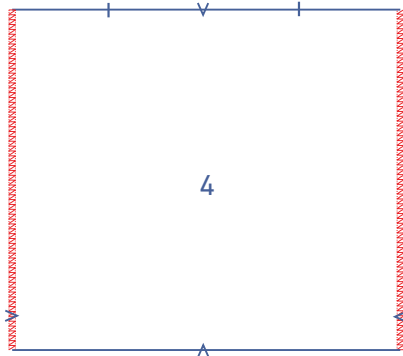

Pin the side seams of the skirt front and back together and sew. Press the seam allowance open.

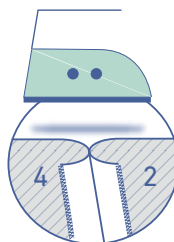

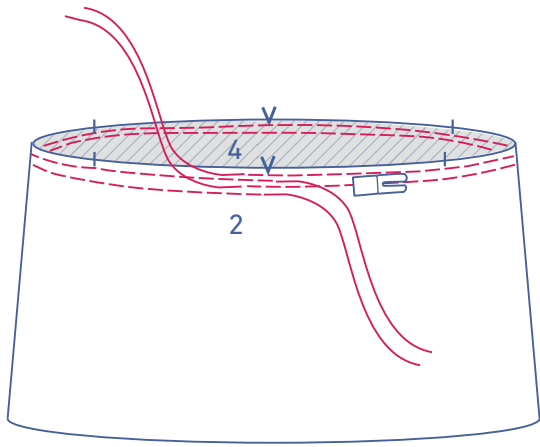

10

Use a long stitch at a low thread tension to sew 2 parallel lines of stitching along the top of the skirt. Leave a length of thread at the start and end of the stitching.

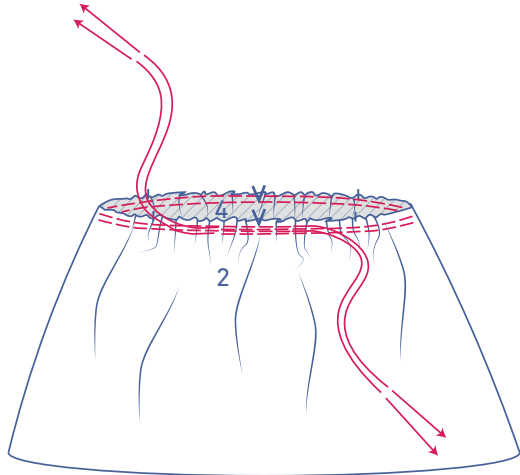

Gently tug the ends of the threads to gather the fabric.

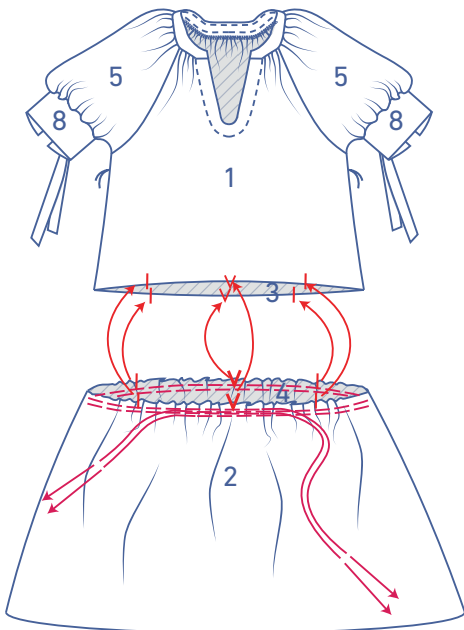

Pin the skirt to the front and back. Distribute the gathers until the notches match.

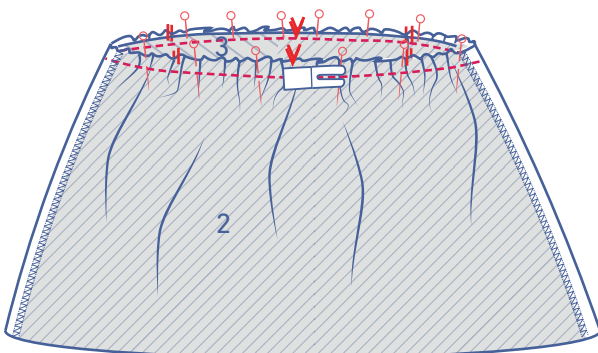

Sew into place.

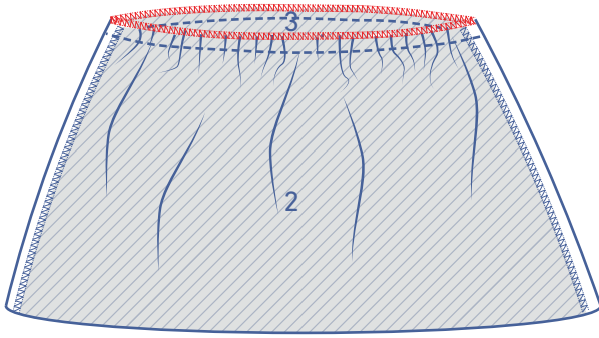

Finish the raw edges with overlock stitching.

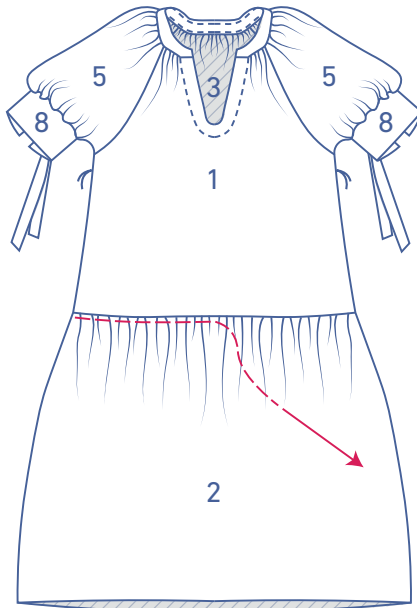

Remove the gathering threads.

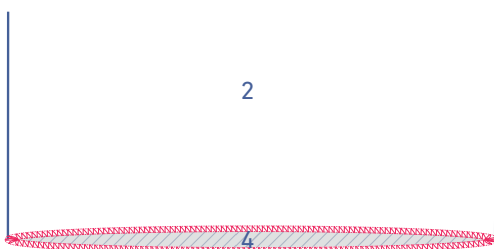

11

Finish the hem with overlock stitching.

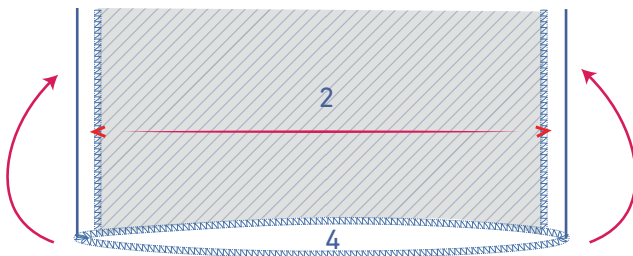

Press the hem allowance over at the V notches.

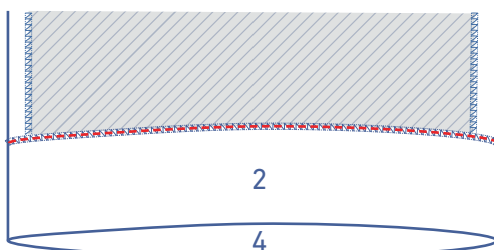

Sew the hem allowance into place all the way around.

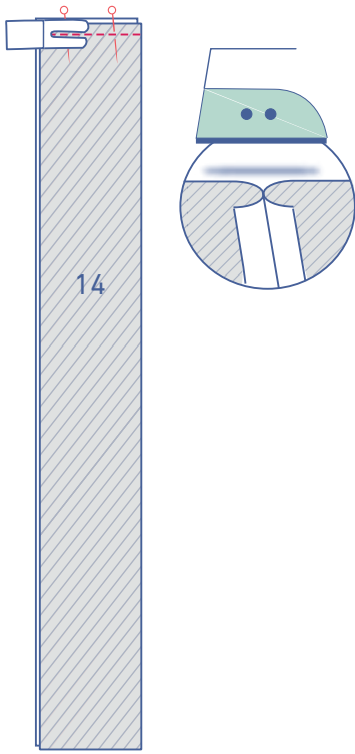

12

Sew the short ends of the belt (14) together. Press the seam allowance open.

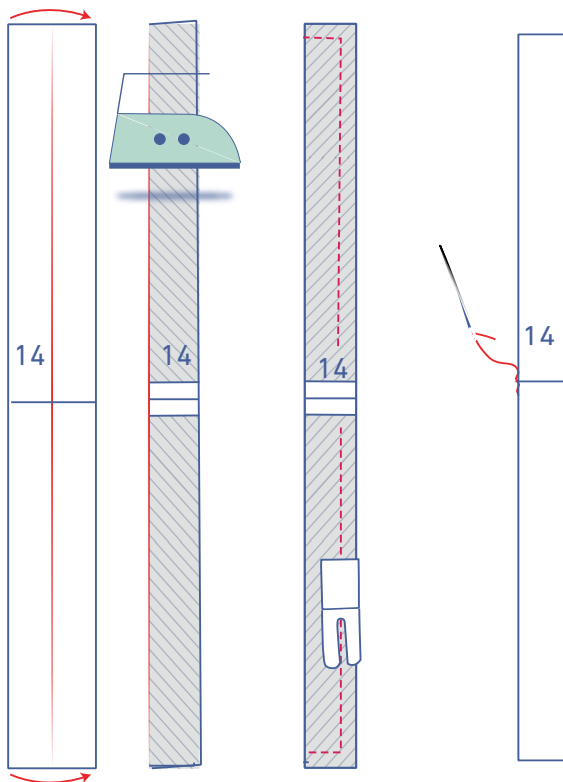

Fold the belt in half with the long ends together and the right sides of the fabric touching.

Sew the indicated edges, but leave an opening to turn the belt the right way out again.

Turn the belt the right way out and sew the opening closed.

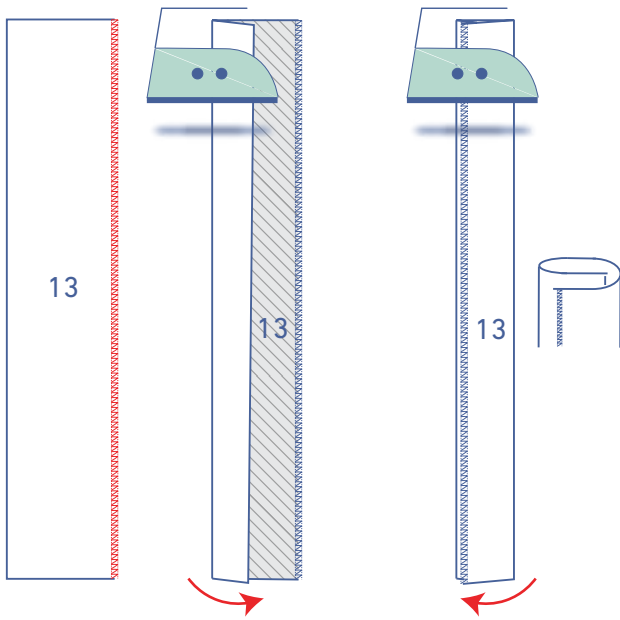

13

Finish one long end of the belt loops (13) with overlock stitching.

Press the unfinished end towards the wrong side, and then press the overlocked end over this.

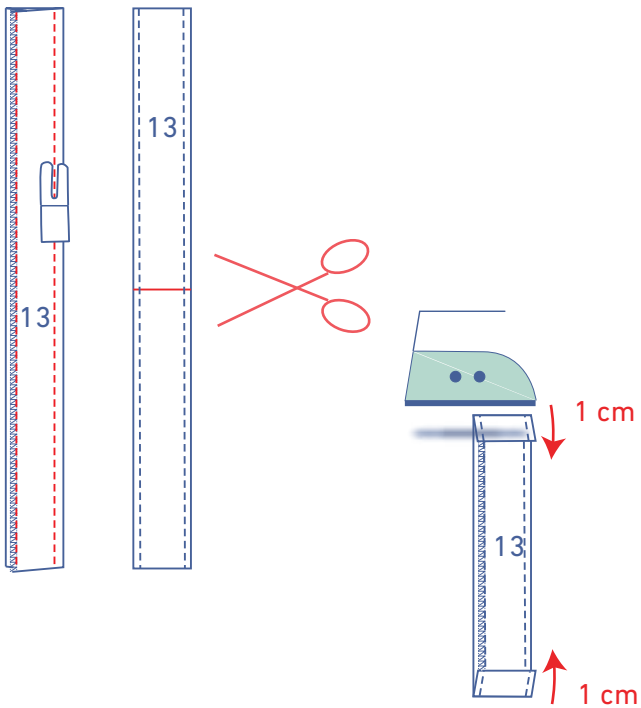

Edgestitch into place.

Cut into two equal parts.

Press the top and bottom ends of each belt loop 1 cm over towards the wrong side.

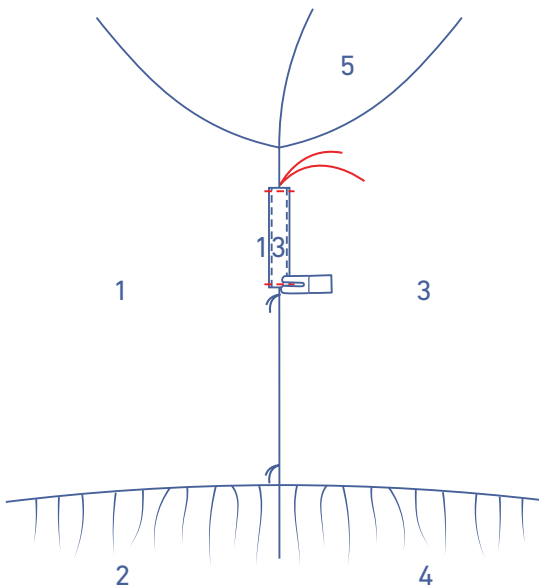

Pin the belt loops to the garment where indicated. Sew into place right next to the edge at the top and bottom.