

Blanca by Fibre ood



Blanca Fibre ⚡ood



4 - 32

No two people have the same body shape, we know that ...
so sewing your own trousers – that fit like a glove – is a treat!
These trousers have got it all: a high, buckled waist, zip, practical
side pockets in the side seam, and pleats. We made Blanca in ankle
length, but the right length for you is whatever you want it to be.

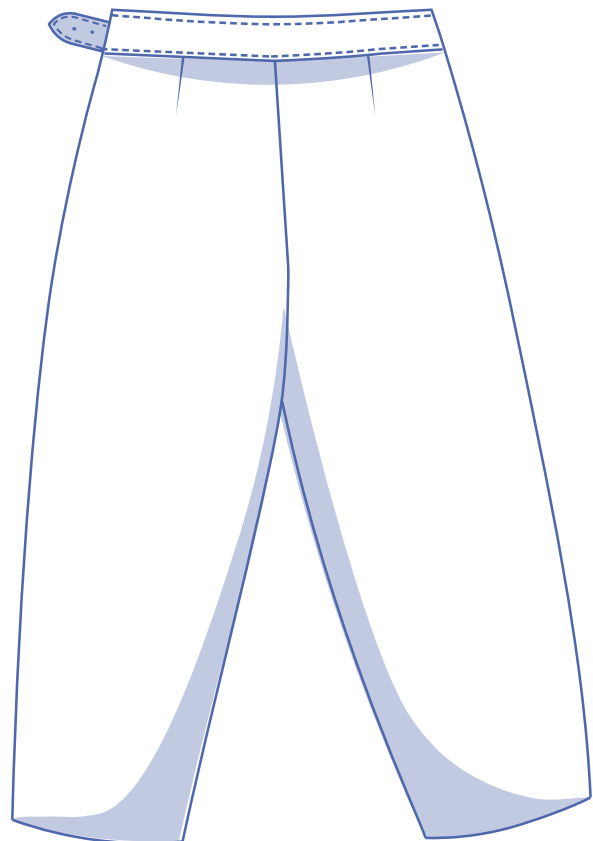
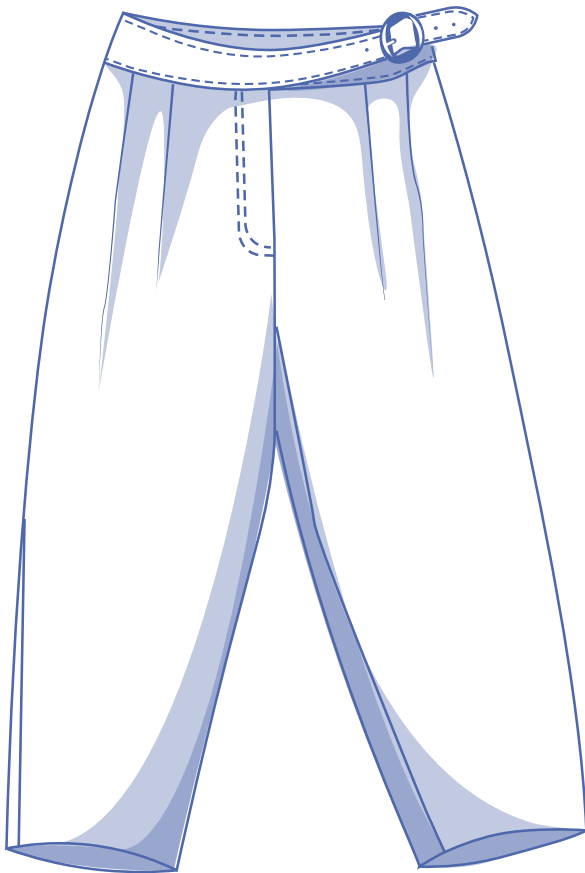

size chart (in cm)

size	4	6	8	10	12	14	16	18	20	22	24	26	28	30	32
body height	160	164	166	167	168	169	170	171	172	172	172	172	172	172	172
W (waist)	66	68	70	74	78	82	84	88	94.5	101	107.5	114	120.5	127	133.5
H (hips)	86	90	94	97	100	103	106	109	115	120	125	130	135	140	145

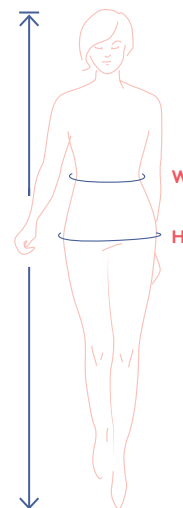

To choose your size, start with your **waistline measurement**. Pick the size that's the best match for your waistline. Next, see which size is closest to your hip measurement. When tracing the pattern, simply trace from the line of one size to the other.

pattern measurements (in cm)

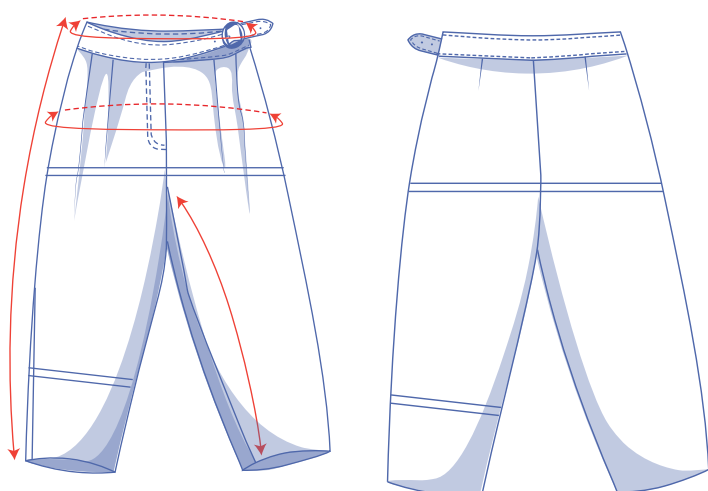

This chart's measurements are the pattern measurements based on the fabric type and serve as a reference. Ease has been added to the width measurements (on top of the exact body measurements) for a more comfortable fit. Blanca is designed to be **fitted at the waist and loose around the hips**. Depending on the preferred cut, you could possibly go a size smaller or larger than the recommended size.

== shorten or lengthen the pattern here

size	4	6	8	10	12	14	16	18	20	22	24	26	28	30	32
side length*	93	93.5	94	94.5	95	95.5	96	96.5	97	97.5	98	98.5	99	99.5	100
inseam length	63	63	63.25	63.25	63.25	63.25	63.25	63.25	63.25	63.25	63.25	63.5	63.5	63.75	63.75
waistline	66	68	70	74	78	82	84	88	94.5	101	107.5	114	120.5	127	133.5
hips**	104.25	108.25	112.25	115.25	118.25	121.25	124.25	127.75	133.75	138.75	144	149	154	159.25	164.25

* Including the waistband.

** Including the pleat allowances.

Compare the stated lengths to the measured or desired lengths. **Shorten** or **lengthen** the trouser legs and/or rise by cutting the pattern pieces at the indicated double lines. Then either increase the distance between the cut pieces by the desired amount (to lengthen) or overlap the pieces (to shorten). Make sure that the CF and CB lines and the side seams are always straight.

IMPORTANT

Adjust the amount of fabric to be used based on these alterations.



notions

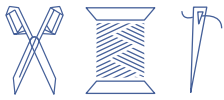

- Thread
- Iron-on interfacing: max. 45 cm
- Snap (Ø 1.5 cm): 1
- Buckle (4 cm): 1
- Eyelets (Ø 4 mm): 5
- Double-sided tape (optional)
- Closed-end zip: see table
- Fabric: see table

zip		4	6	8	10	12	14	16	18	20	22	24	26	28	30	32
length	cm	15	15	15	15	15	15	15	18	18	18	18	18	18	18	18

fabric		4	6	8	10	12	14	16	18	20	22	24	26	28	30	32
fabric width 110 cm	cm	210	215	215	215	220	260	260	265	280	285	290	290	290	295	305
fabric width 140 cm	cm	155	155	175	180	195	205	210	210	210	220	220	260	260	265	265

The corresponding fabric layout can be found on page 6 of these sewing instructions.

fabric advice The following fabric options – with or without stretch – are perfect for Blanca: corduroy, velvet, leather(ette), gabardine, denim, cotton twill, and woven jacquard. Steer clear of light, flimsy, or drapey fabrics and select a fabric that is stiff/heavy enough instead.



Proud to be #Sewista

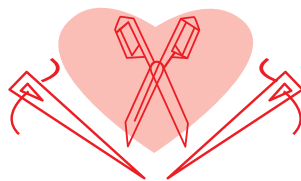

pattern pieces & seam allowances (in cm)

To sew the garment as described in the instructions, draw the illustrated seam allowances around the paper pattern pieces before cutting them out. If you are using a PDF pattern, the pattern can be printed with or without seam allowance. To find out more, watch the [video](#).

for fabrics that fray

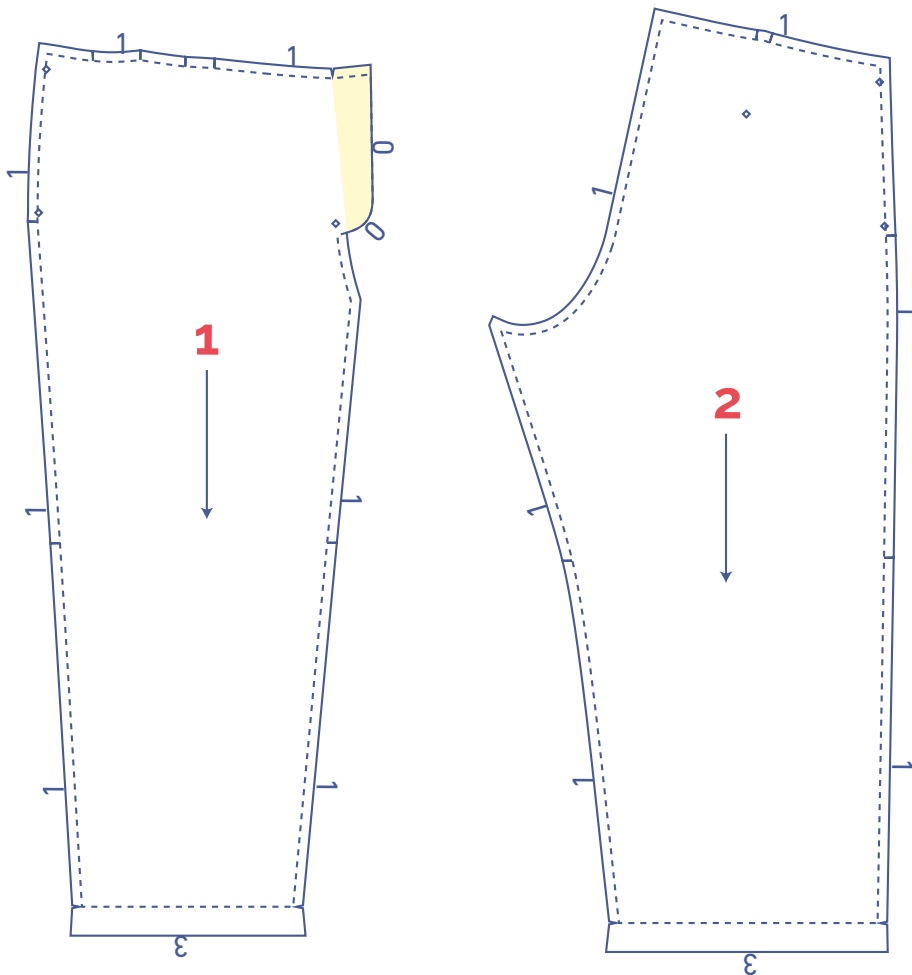

- 1. front: 2x
- 2. back: 2x
- 3. RF waistband: 2x
- 4. LF waistband: 2x
- 5. waistband back: 2x on the fabric fold
- 6. loop: 1x
- 7. pocket: 4x
- 8. fly: 1x

IMPORTANT

The pieces highlighted in light yellow have iron-on interfacing attached to the wrong side.

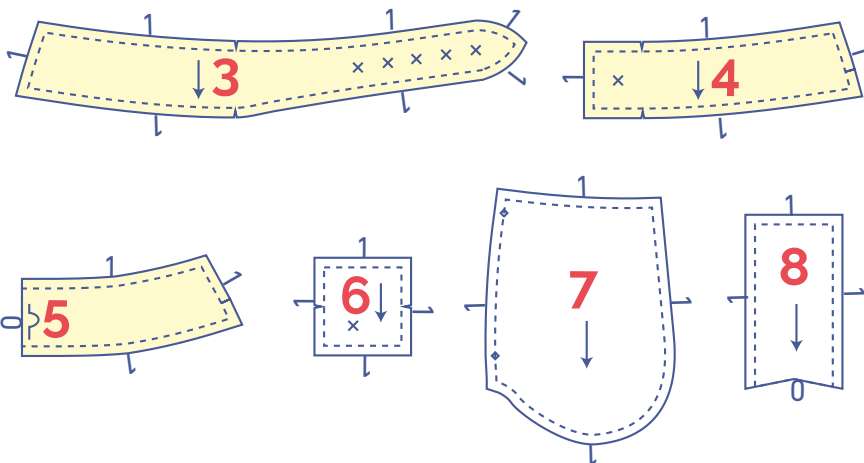

?	material type
	fabric
	iron-on interfacing

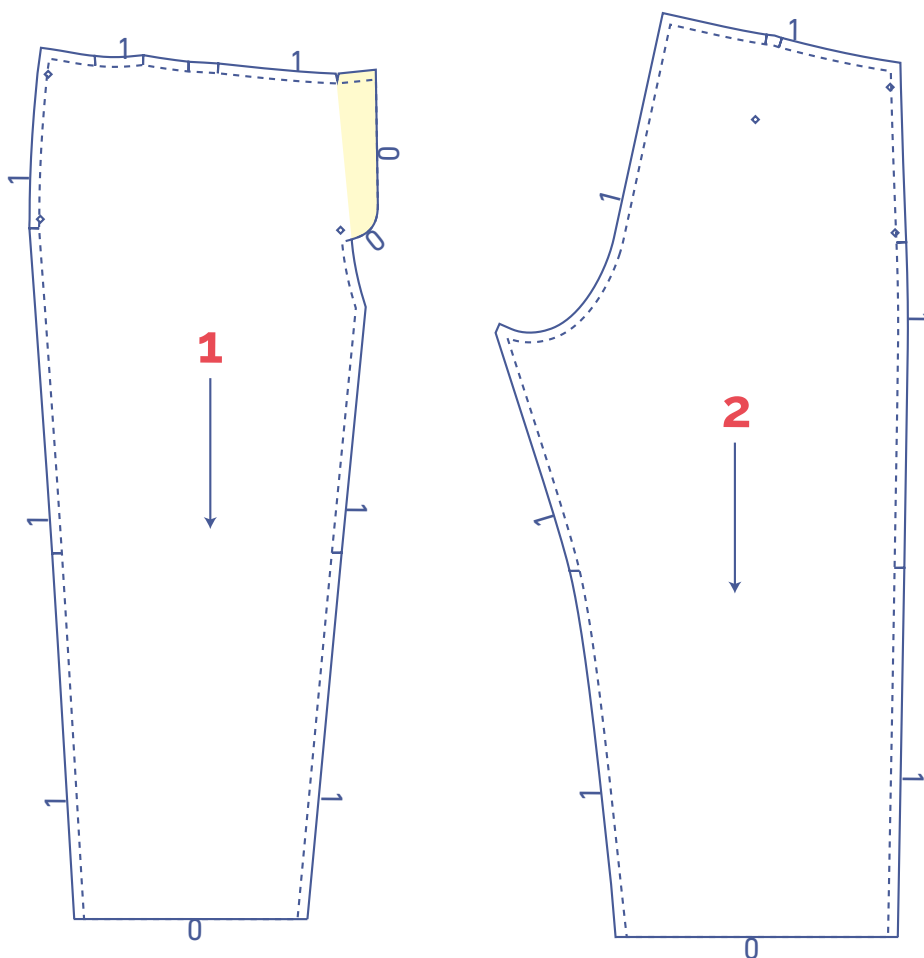

for fabrics that don't fray

You don't need to provide seam allowance at the hem for pattern pieces 1 and 2. All other pattern pieces have the same seam allowance as shown above.



 material type
 fabric
 iron-on interfacing

fabric layout – solid fabrics
fabric width 110 cm

4 - 12

14 - 26

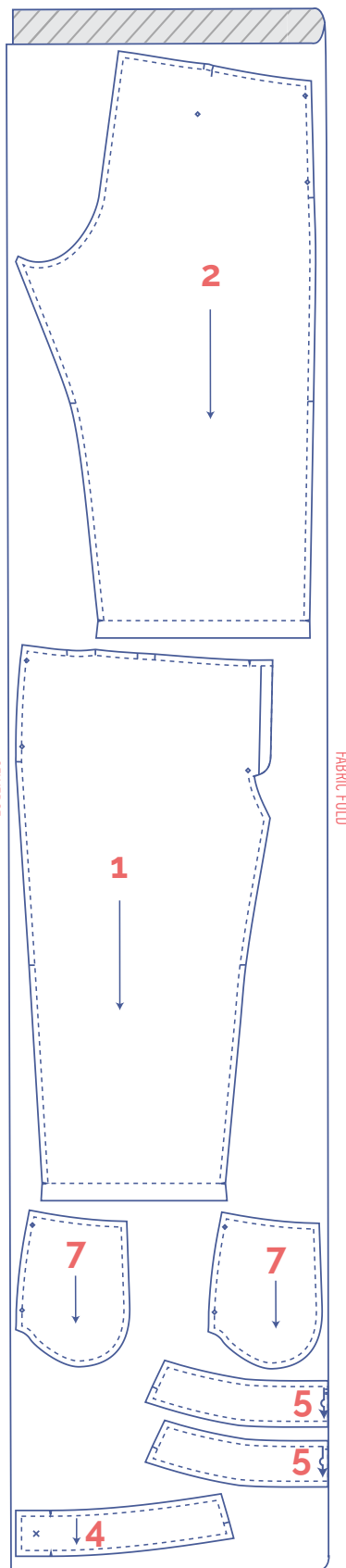
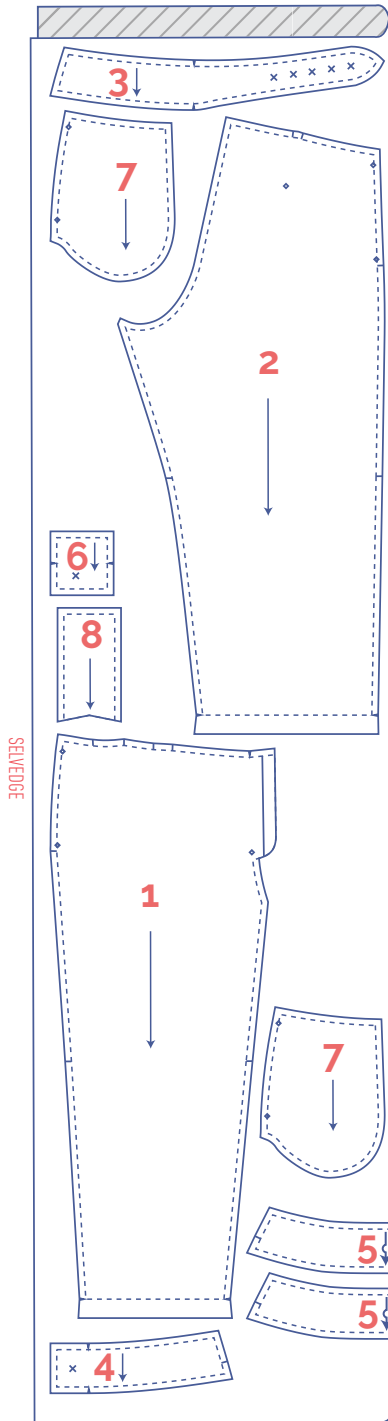

IMPORTANT

You only need pattern pieces 6 and 8 once.

+

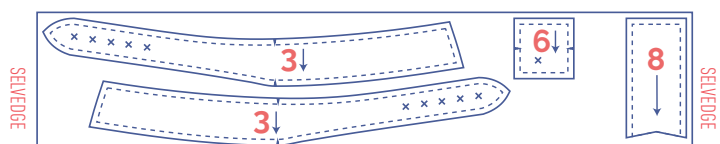

fabric layout – solid fabrics
fabric width 110 cm

28 - 32

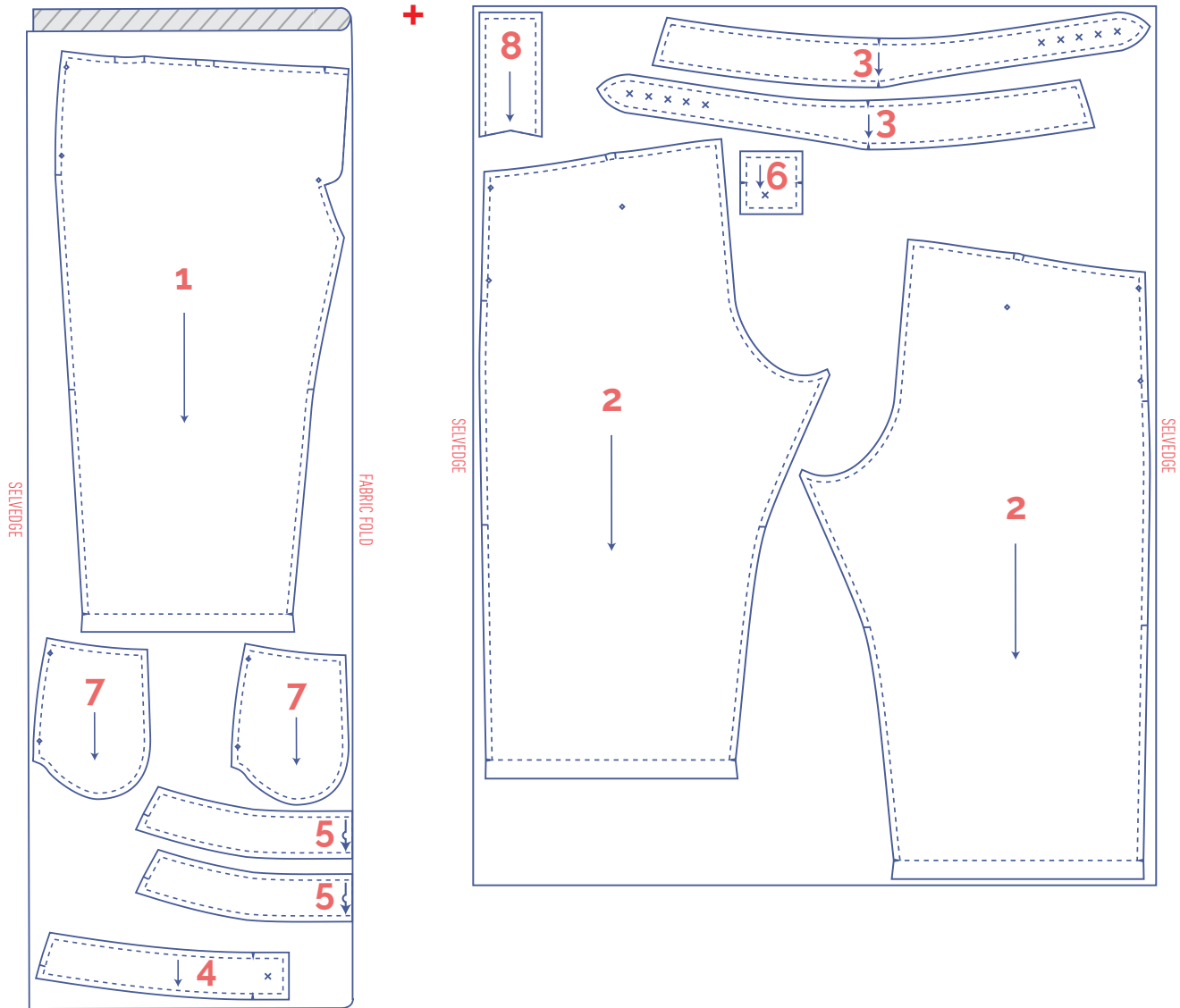

fabric layout – solid fabrics
fabric width 140 cm

4 - 8

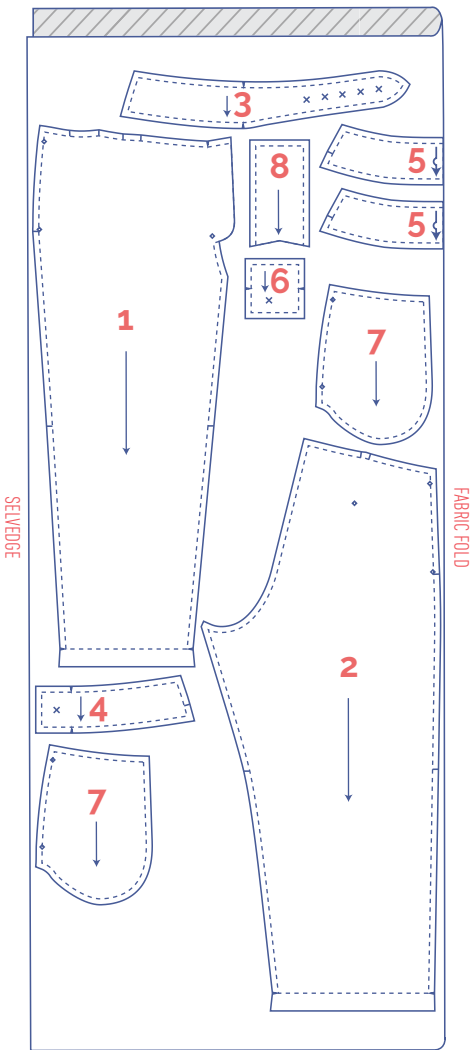

IMPORTANT

You only need pattern pieces 6 and 8 once.

10 - 24

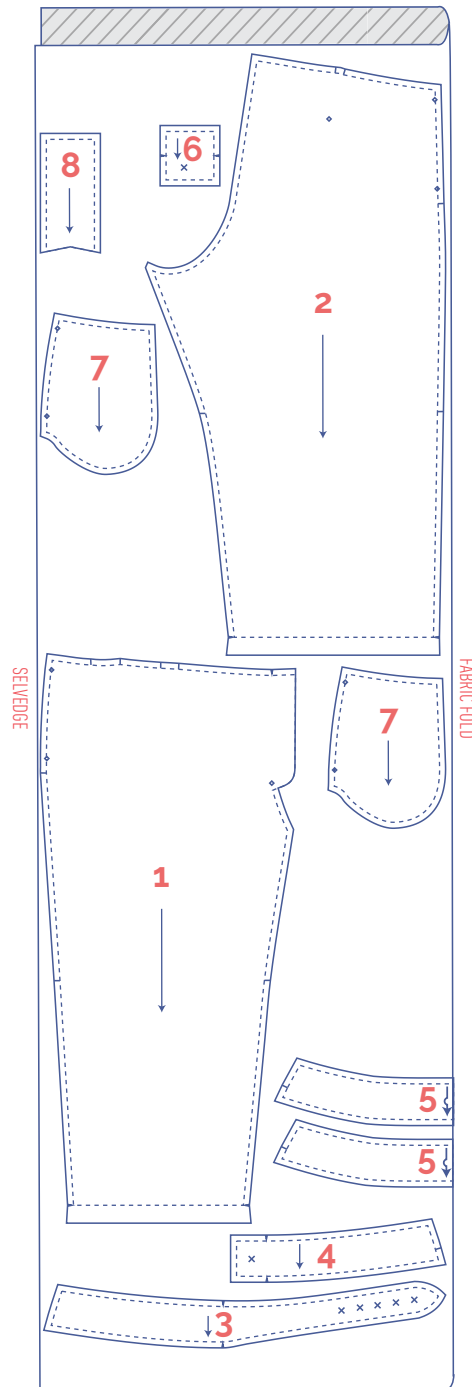

IMPORTANT

You only need pattern pieces 6 and 8 once.

fabric layout – solid fabrics

fabric width 140 cm

26 - 32

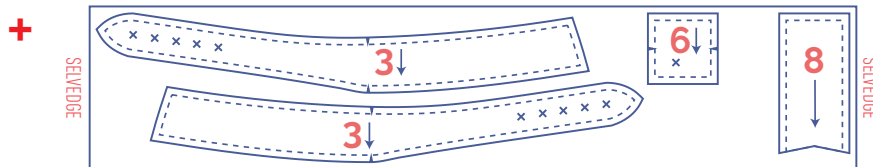
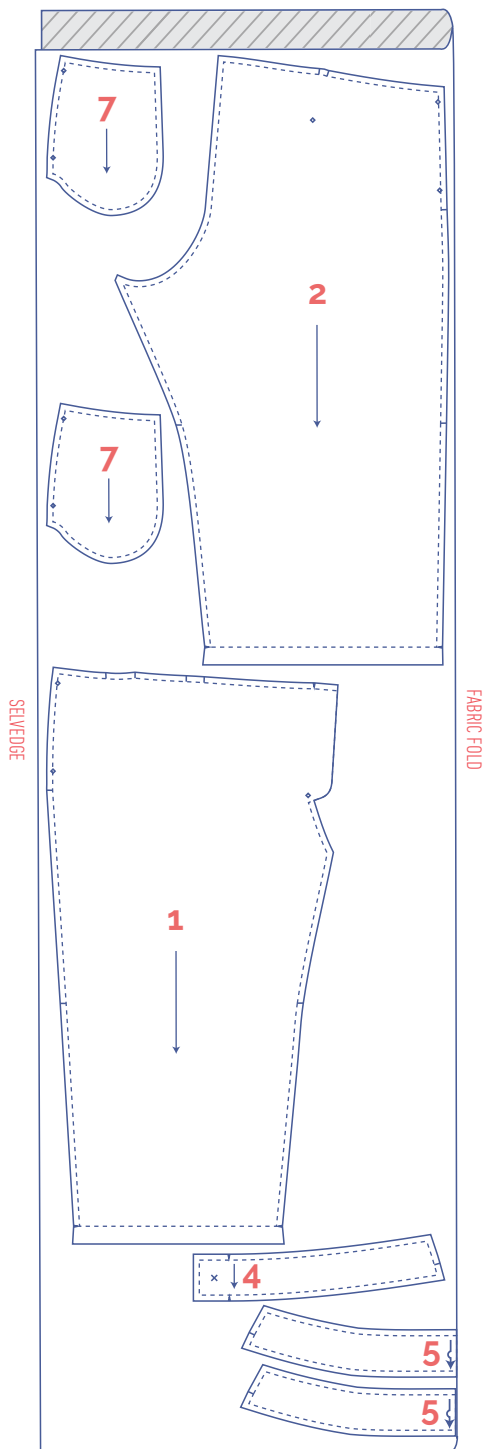

marking pattern pieces

	Notch the pattern paper and fabric at the following points
	single notch
	double notch
V	V notch



	Mark the following points using marking thread
	centre point
	snap/button

sewing instructions



The method used to finish the seams depends on the fabric used.
The pieces are always sewn together with the right sides of the fabric facing, unless stated otherwise.



F	front	
B	back	
RF	right front	●
LF	left front	●
CF	centre front	
CB	centre back	
	right side	
	wrong side	
	iron-on interfacing	

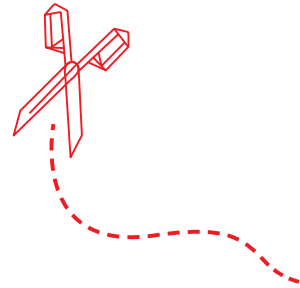

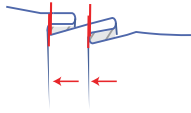

1

Match the notches in the top of both front pieces (1) with the right sides of the fabric facing.

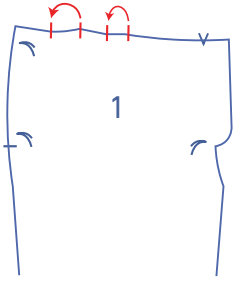

Stitch 2 cm of each pleat allowance vertically into place.

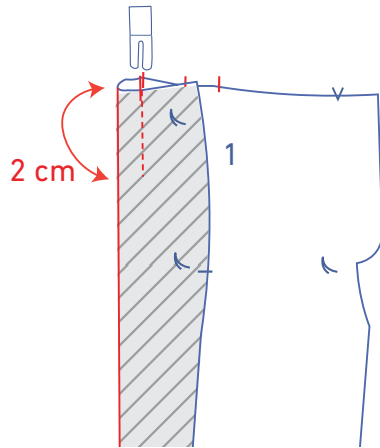

Place the front with the wrong side facing up. Press the pleat allowances towards the CF and then pin them into place.

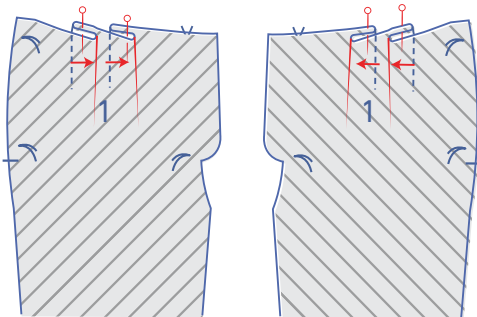

Turn the front back over so that the right side is facing up. Sew the pleat allowances into place at presser foot width from the raw edge.

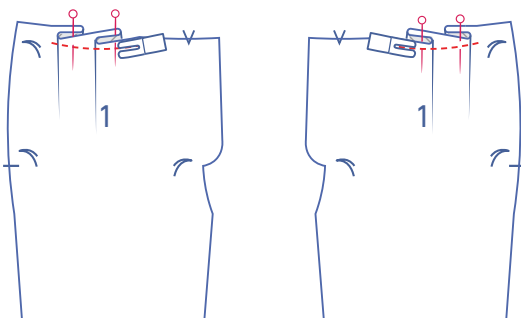

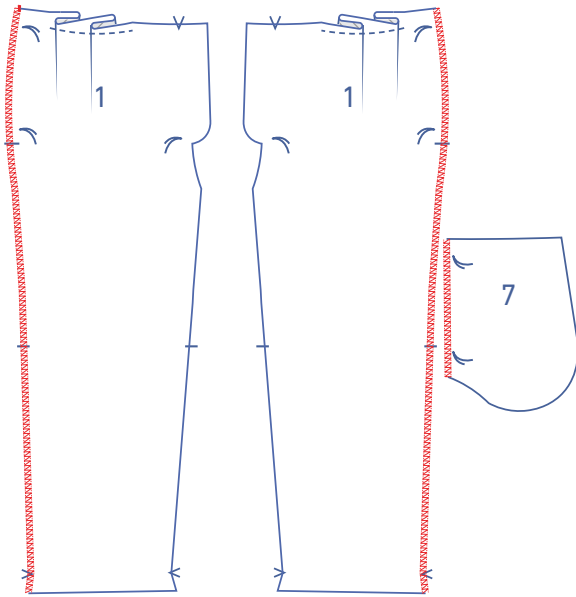

Finish the sides of the front and the straight pocket edges (7) with overlock stitching where indicated.

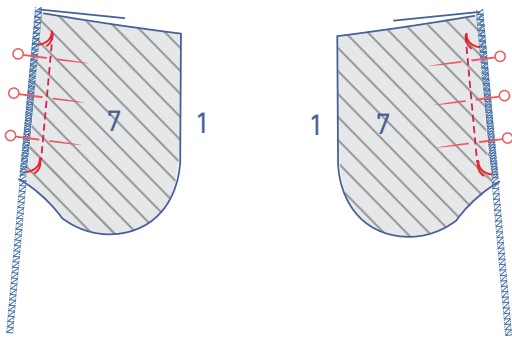

Pin the 2 pocket pieces to the side seams of the front, matching the marking threads. Sew the pocket pieces into place between the marking threads.

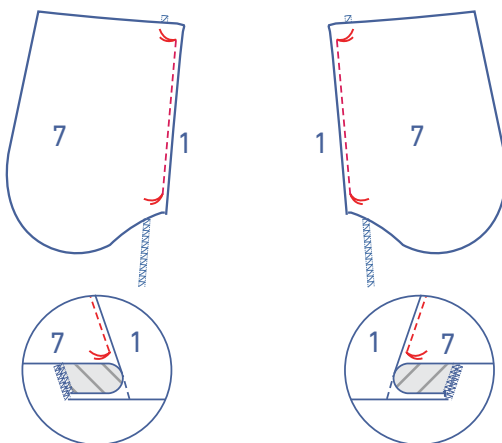

Fold the pocket pieces over and sew the pocket to the seam allowance underneath, between the marking threads and right next to the seam.

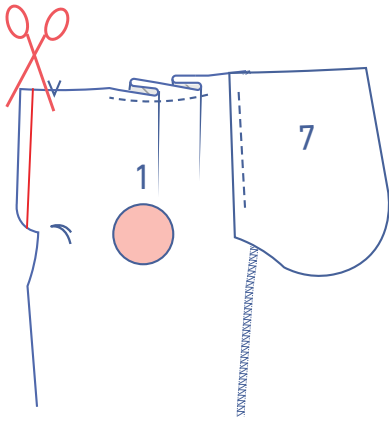

2

Cut a piece from the LF along the indicated line.

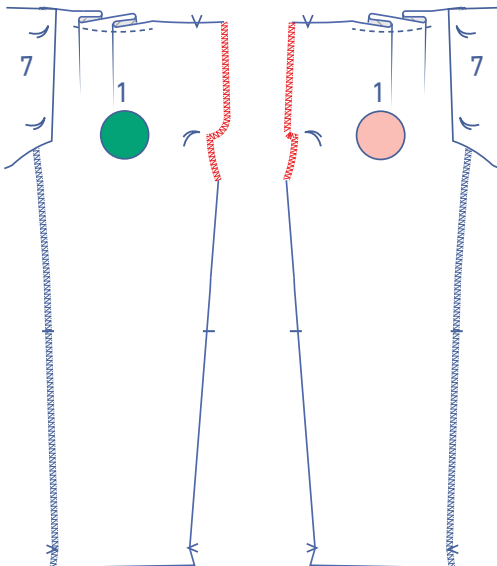

Finish the raw edges on both front pieces with overlock stitching where indicated.

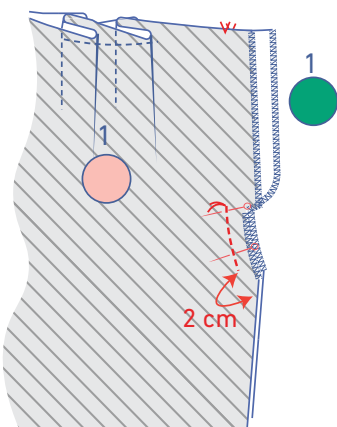

Pin the V notches and marking threads of the RF and LF together. Please note: the RF fly extends past the LF. Sew the CF seam from the marking thread to approx. 2 cm before the edge.

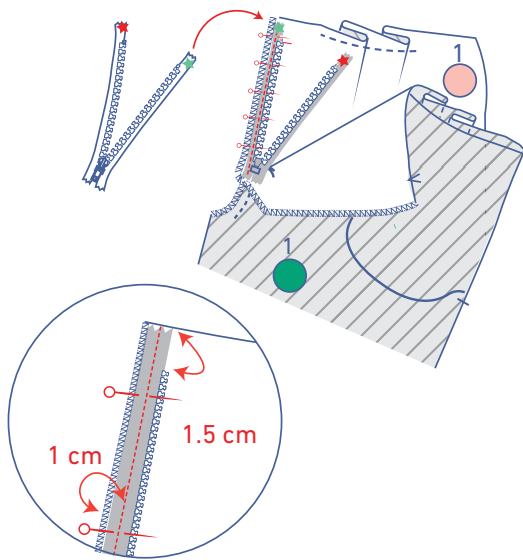

Start by placing the zip with the right side facing up. Open the zip and flip the green star zip tape over to the right and onto the LF. The edge of the zip tape should be next to the overlocked stitching, and the zip teeth should start 1.5 cm under the top edge. Pin and sew into place at 1 cm from the CF seam (= the middle of the zip tape) with the zipper foot.

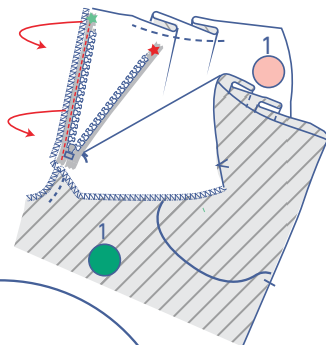

Fold the zip tape back to the left.

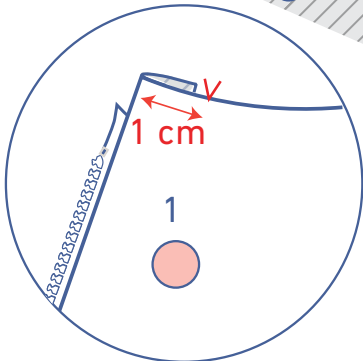

Close the zip and place both front pieces together with the right sides touching, making sure the V notches in the CF match. Press both front pieces neatly flat.

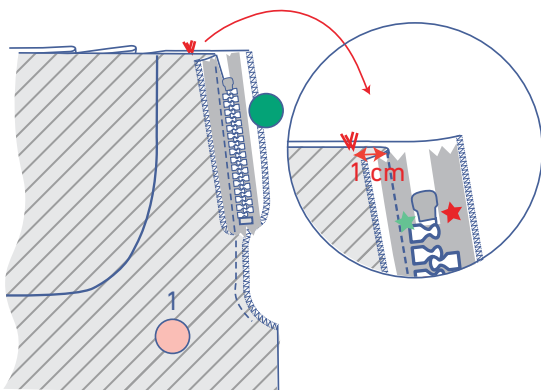

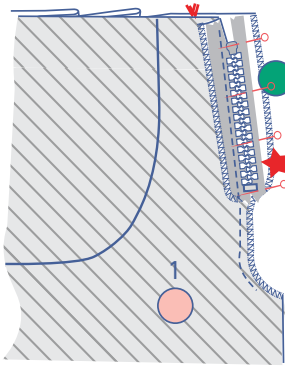

Pin the red star zip tape into place on the RF fly.

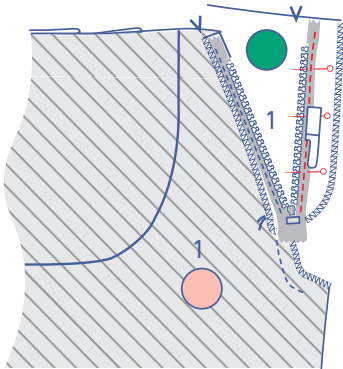

Open the zip and stitch the zip tape into place with the zipper foot.

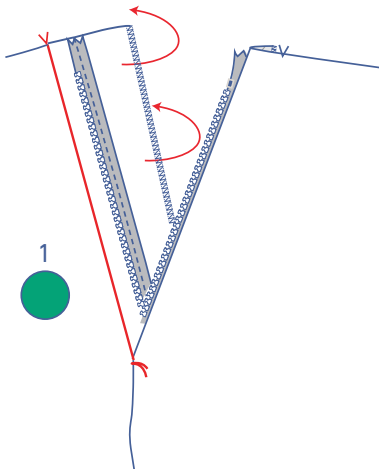

Fold the RF fly towards the wrong side at the V notch.

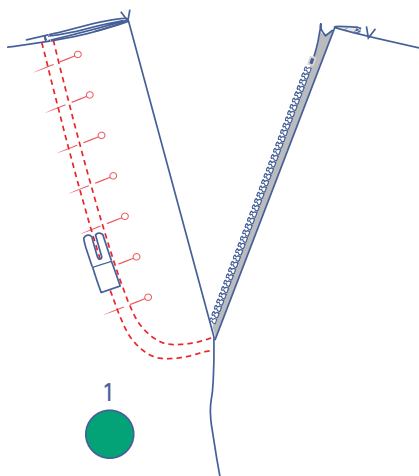

Pin into place and topstitch two parallel lines along the edge of the fly on the right side of the fabric, anchoring all layers.

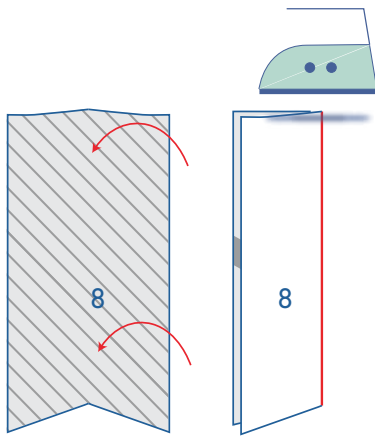

3

Press the fly (8) in half with the long ends together and the wrong sides of the fabric facing.

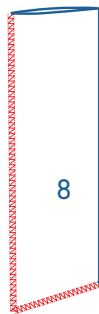

Finish the raw edges with overlock stitching where indicated.

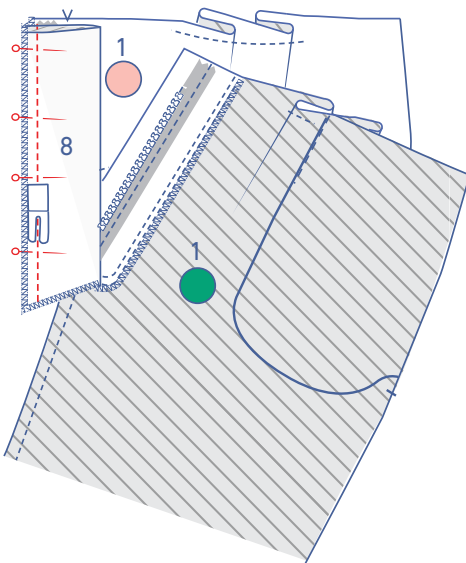

Pin the fly to the seam allowance of the LF and the zip and sew into place.

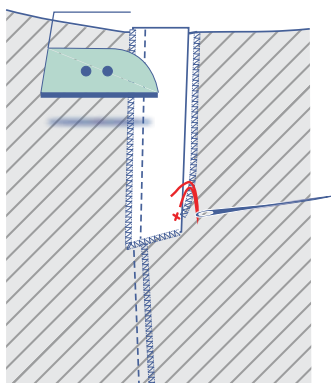

Press the fly over and close the zip. Hand stitch the RF fly and LF fly pieces together with a stitch or two at the bottom.

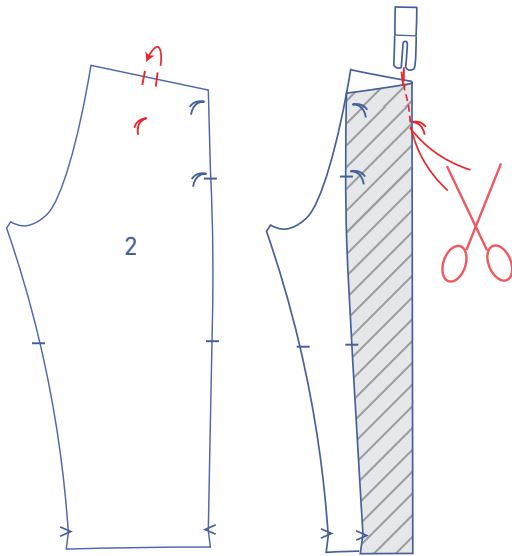

4

Match the notches at the top of the back (2) with the right sides of the fabric facing. Sew the dart or contour in a slightly curved line towards the marking thread. Stitch up to and just past the marking thread, so that you've sewn past the fabric. Snip the threads and tie a knot.

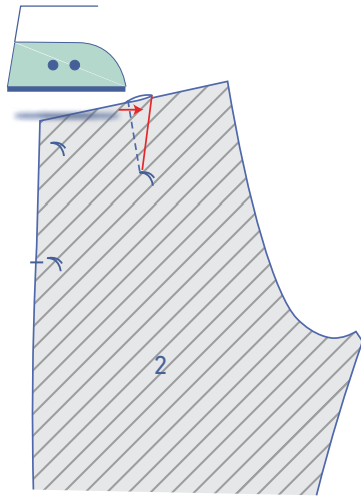

Press the dart towards the CB.

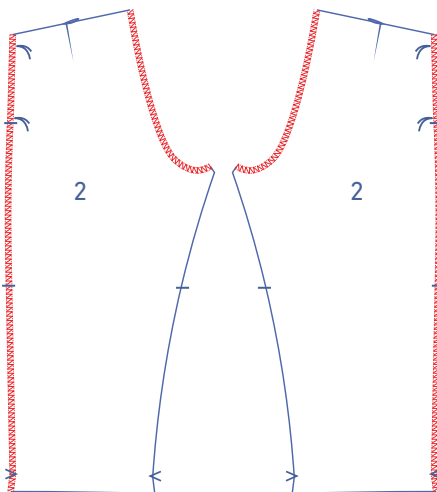

Finish the CB seams and sides with overlock stitching.

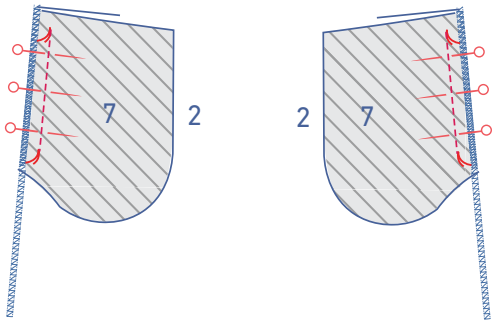

Pick up the 2 remaining pocket pieces and pin them to the side seams of the back, matching the marking threads. Sew the pocket pieces into place between the marking threads.

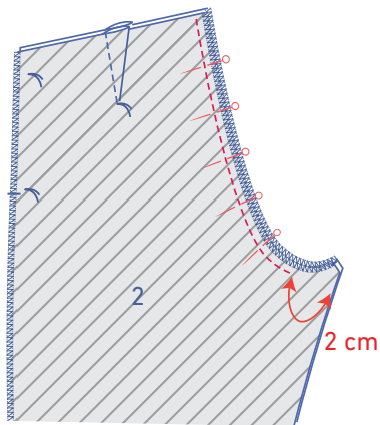

Pin the RB and LB together. Sew the crotch seam, stopping around 2 cm from the raw edge as shown.

5

Pin the side seams of the trousers above and below the pocket opening together (as indicated by the marking threads) and sew into place. Press the seam allowances open.

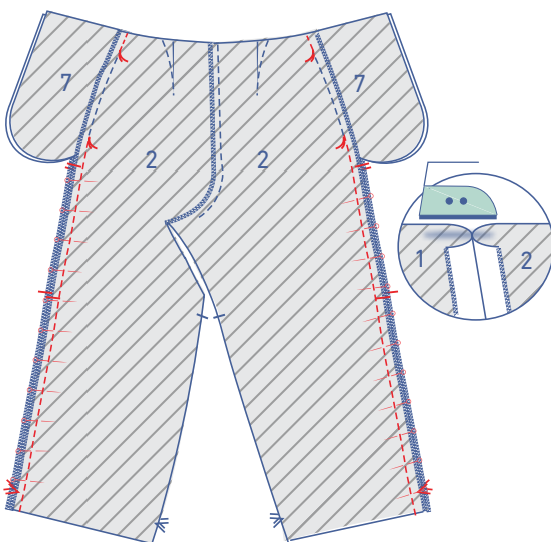

Then pin and stitch the small bit of pocket side seam over and under the pocket opening. Press the seam allowances open.

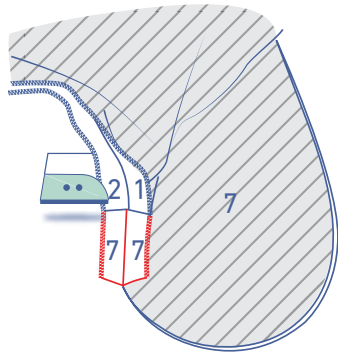
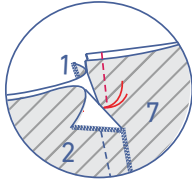

Pin and sew the contours of the pocket pieces together.

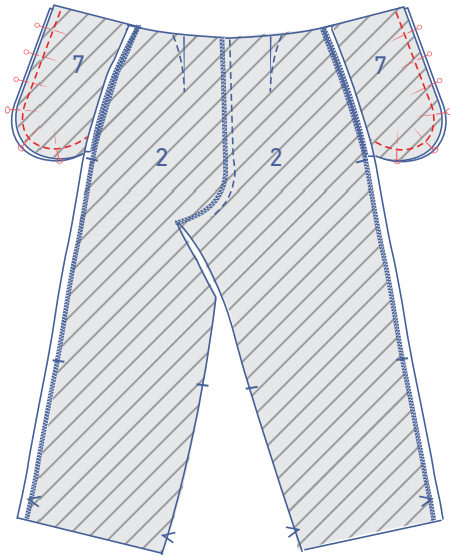

Finish the raw edges with overlock stitching.

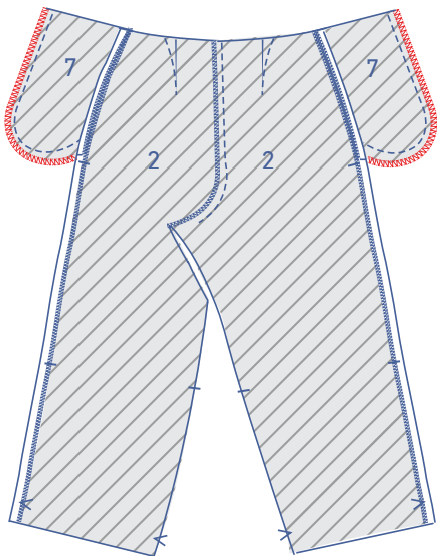

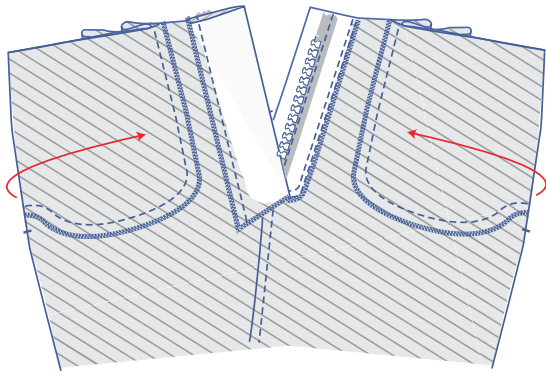

Neatly fold the pocket pieces over towards the wrong side of the front. Carefully match the top of the pockets to the top of the front.

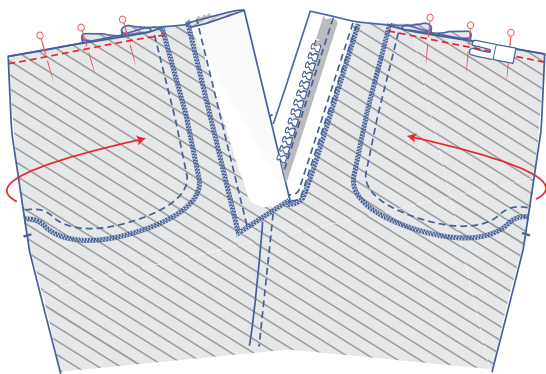

Sew the top of the pocket to the front at presser foot width from the raw edge to hold it in place.

6

Pin and sew the inseams together.

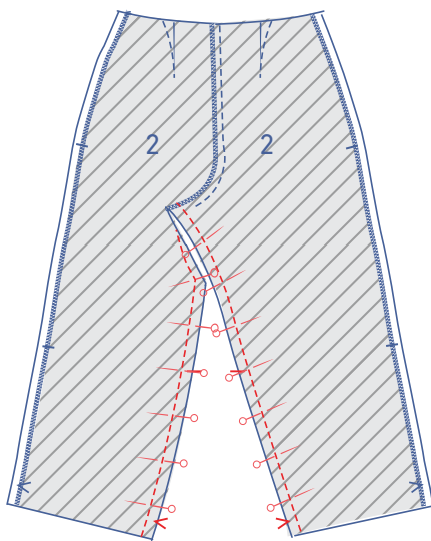

Finish the raw edges with overlock stitching.

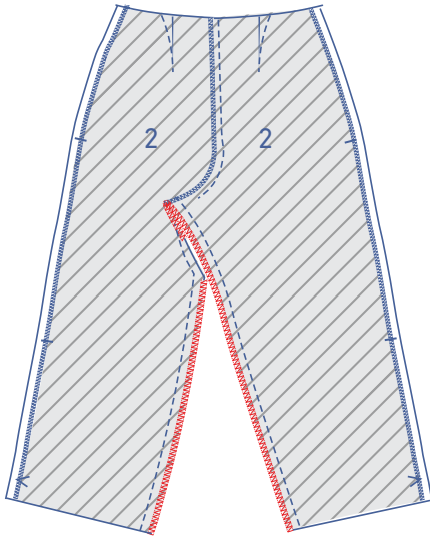

Slide one trouser leg into the other with the right sides of the fabric touching. Pin and stitch the rest of the crotch seam.

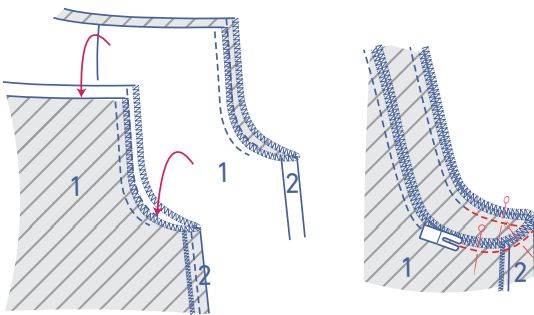

7

Fold the loop (6) in half at the V notches with the right sides of the fabric facing.

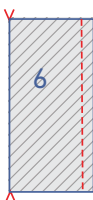
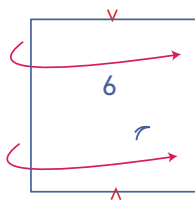

Sew the indicated end.



Turn the loop the right way out.



Finish the indicated end with overlock stitching.

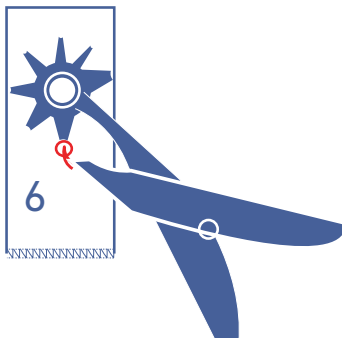

Make a hole for the belt buckle pin to go through later.



Finish the contours of the hole with fine zigzag stitching (satin stitch).

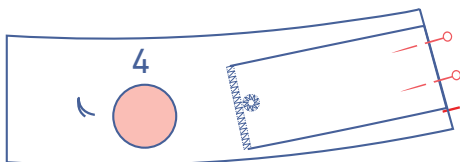

8

Make 2 waistbands.

- a waistband for the outside with a loop for the buckle in the left side seam

Pin the loop to the LF waistband (4) where indicated with the right side of the loop facing up. The bottom of the loop meets the single notch in the LF waistband.

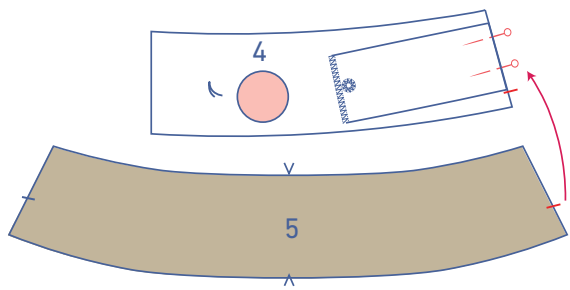

Pin and sew the side seams of the waistband LF + loop and the waistband back (5) together.

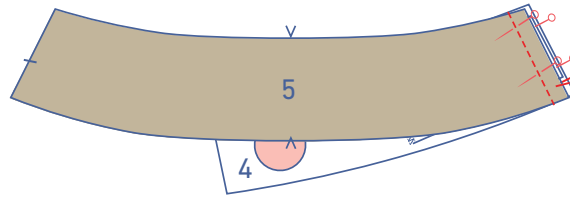

Press the seam allowance towards the back.

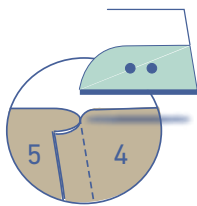

Pin and sew the side seams of the waistband RF (3) and waistband back (4) together. Press the seam allowance towards the back.

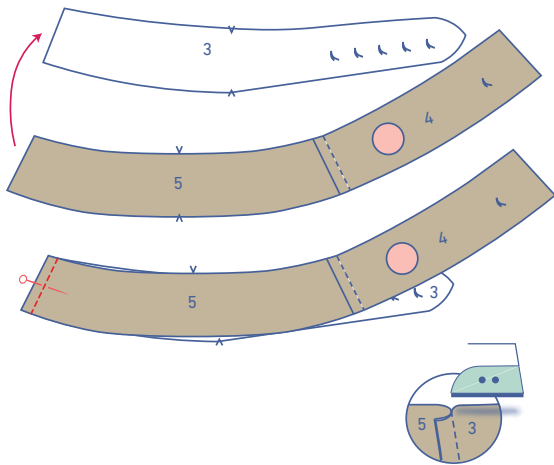

- a waistband for the inside without loop.

Pin and sew the side seams of the remaining waistband pieces (LF, RF, and back). Press the seam allowance towards the front.

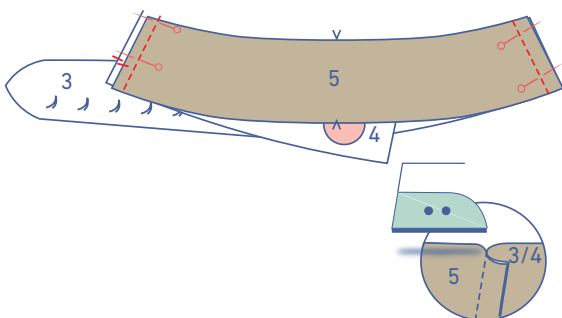

Finish by overlocking the bottom of this waistband.

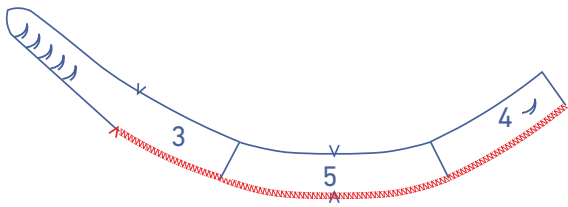

Pin and sew the waistband with the loop to the top of the trousers. The LF waistband should extend past the fly by 1 cm. For the RF waistband, the V notch should line up with the finished CF.

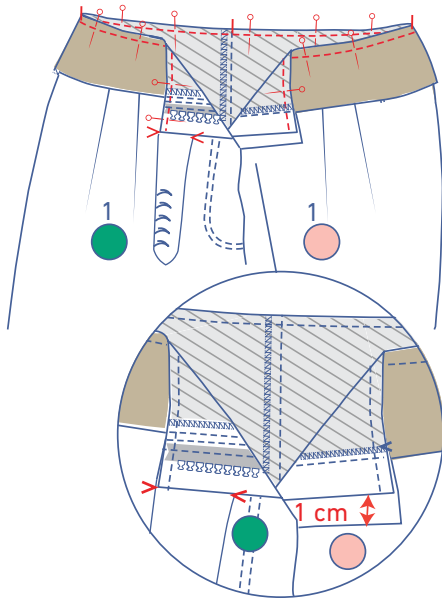

Fold the waistband with the loop up.

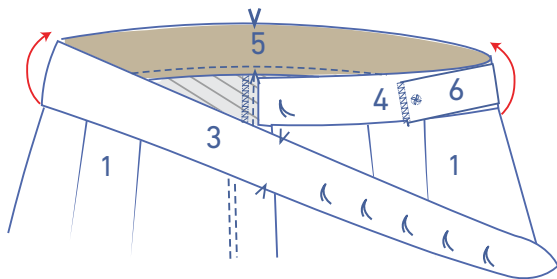

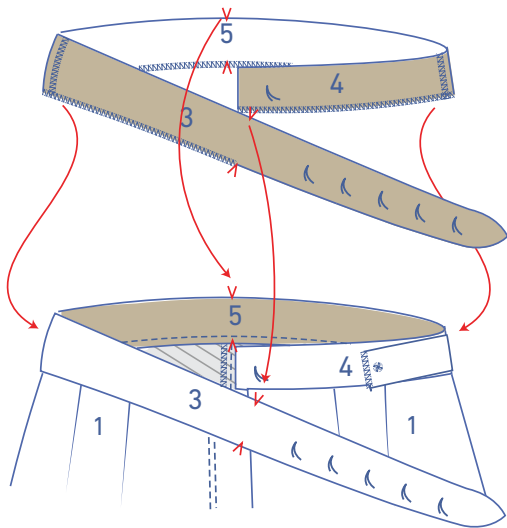

Pin and sew the ends of both waistbands together where indicated.

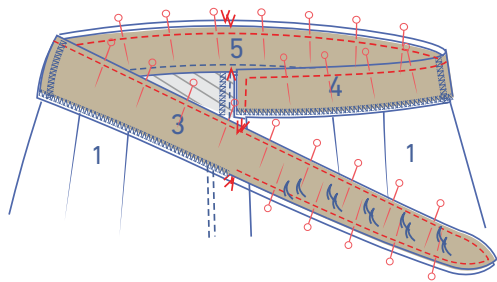

Trim the seam allowance at the corners.

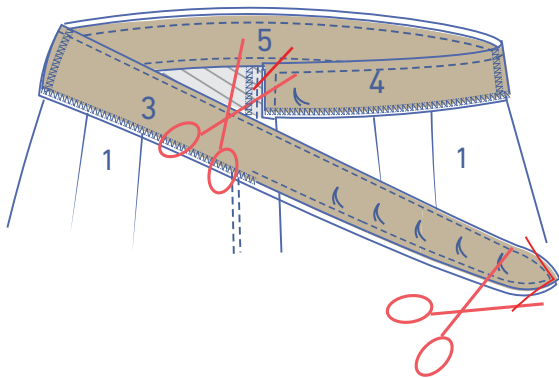

Turn out the waistband/belt extension the right way. Neatly press flat.

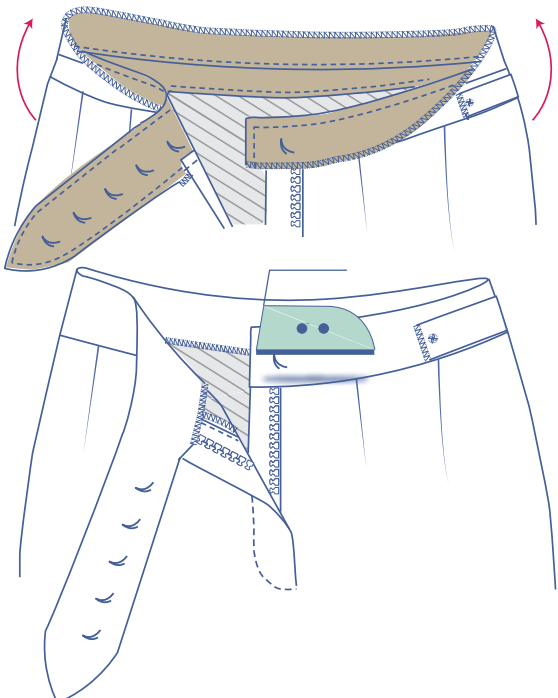

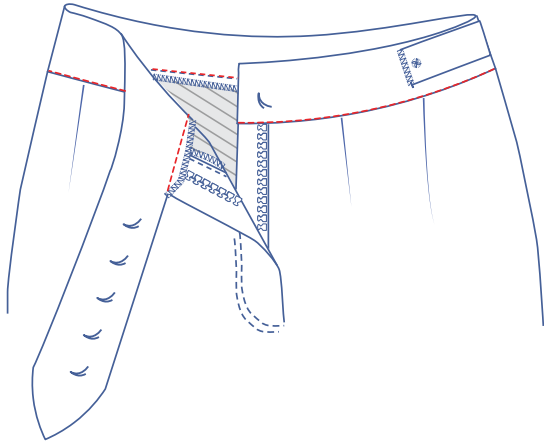

Pin the waistband into place along the right side of the trousers and stitch in the ditch to secure.

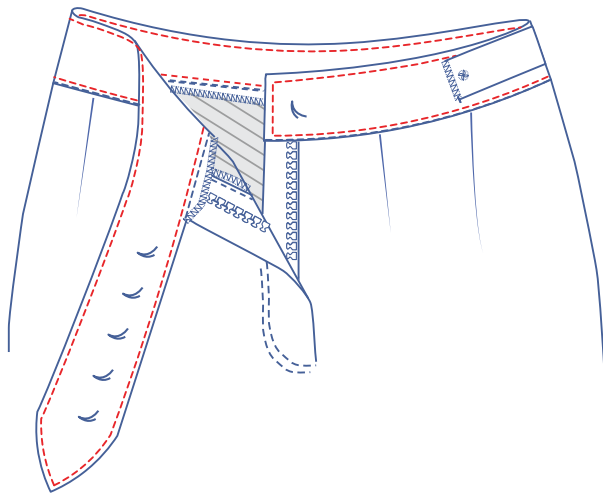

Topstitch all the way around right next to the edge.

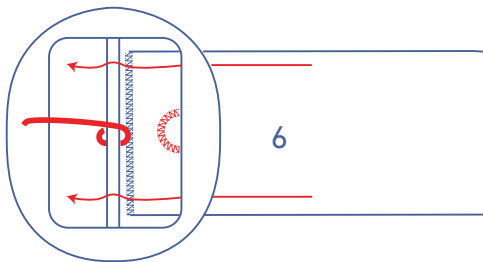

Thread the overlapped end of the loop through the buckle and insert the pin through the hole.

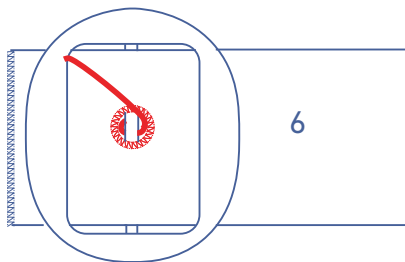

1 cm

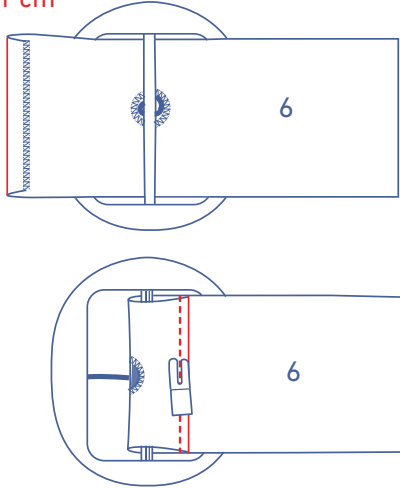

First, fold the overlocked end 1 cm over. Then fold over again and sew into place next to the fold line.

9

Sew the snap fastener on where indicated.

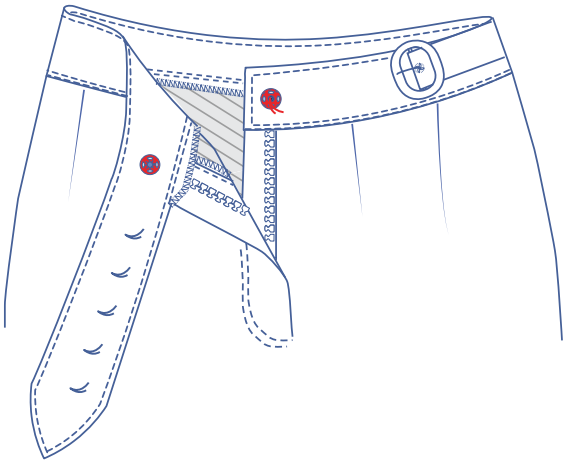

Attach the eyelets where indicated.

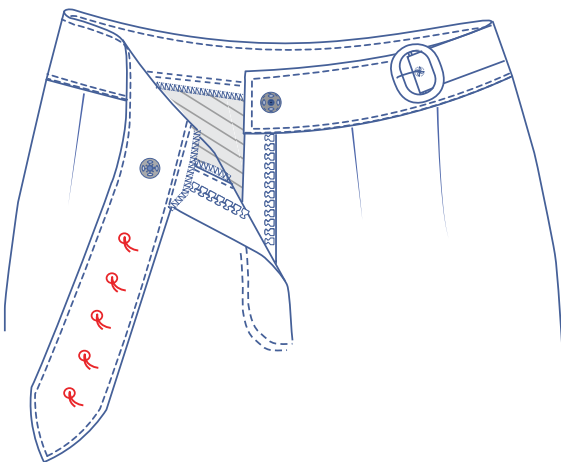

10

If you are making Blanca in leather(ette), the hems don't need to be finished because the fabric won't fray. Does an unfinished hemline still just feel wrong to you?

Then, either secure the hem allowance with double-sided tape or fold the hem allowance over twice and sew into place.

