

Ermine by Fibre ⚡ood



Ermine by Fibre ⚡ood



XS - XXXL

For Ermine, we started with the austere route with simple set-in sleeves, a round neckline, separate button placket, and bias tape for the neckline finish. But then it was impossible not to add a romantic flourish to this blouse! The triangular yoke features sweet gathers at the bottom. Stay understated and make Ermine in a simple solid or turn up the sound with a print explosion. The outfit options are myriad in combination with trousers or a skirt. The more cheerful, the better!

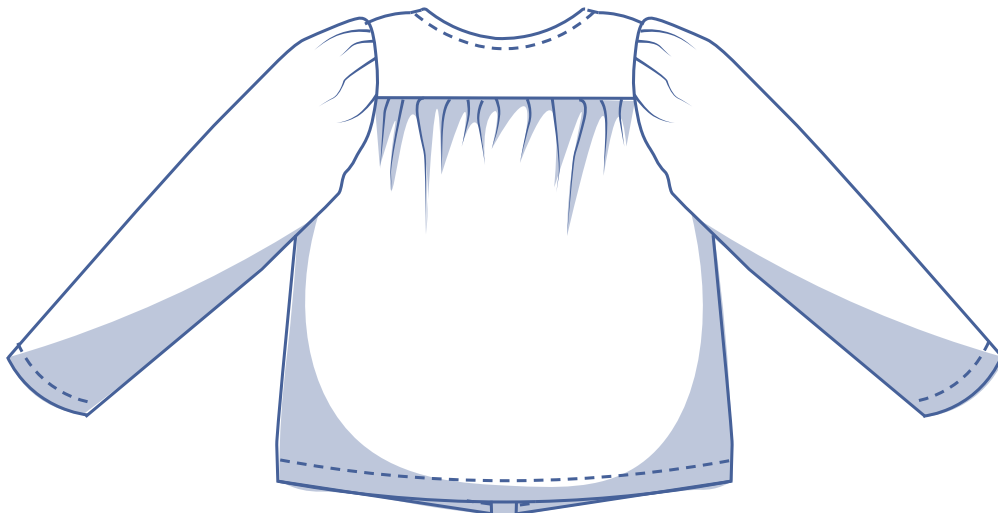
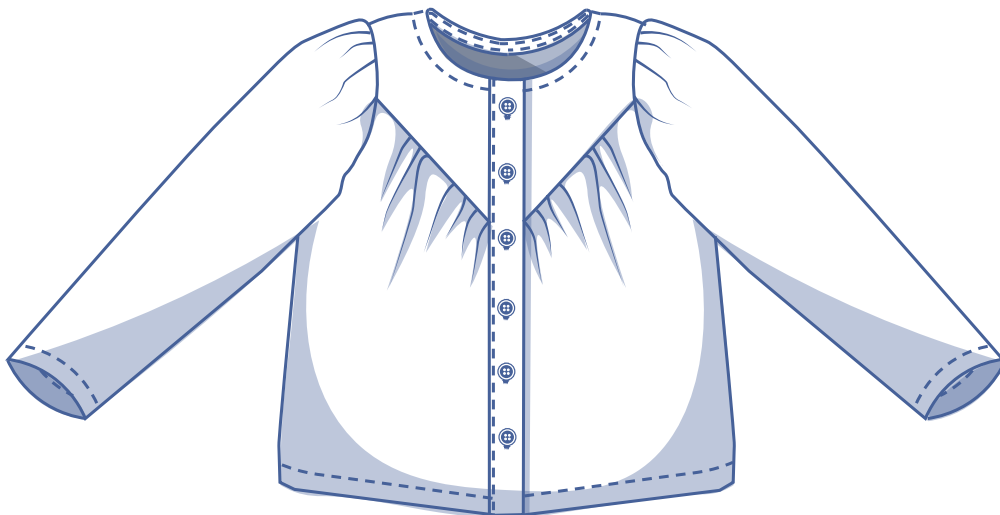

size chart (in cm)

size	XS		S		M		L		XL		XXL		XXXL		
	4	6	8	10	12	14	16	18	20	22	24	26	28	30	32
body height	160	164	166	167	168	169	170	171	172	172	172	172	172	172	172
B (bust)	76	80	84	88	92	96	100	104	110	116	122	128	134	140	146
H (hips)	86	90	94	97	100	103	106	109	115	120	125	130	135	140	145

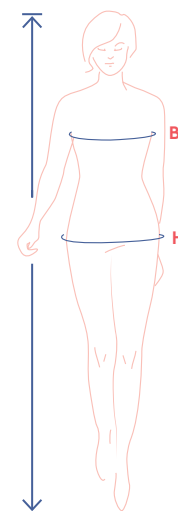

Choose your size based on your **bust measurement**. If your hip measurements are wider than those in the size chart, check the hem circumference in the size chart below to see if there's enough room or whether the pattern needs to be altered. It's easy to do. Simply trace the line of the one size instead of the other.

pattern measurements (in cm)

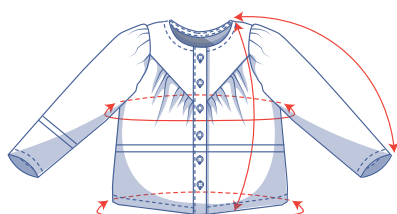

This chart's measurements are the pattern measurements based on the fabric type and serve as a reference. Ease has been added to the width measurements (in addition to the exact body measurements) for a more comfortable fit. Ermine is designed to have a **loose cut**. Depending on the preferred cut, make the pattern a size bigger or smaller.

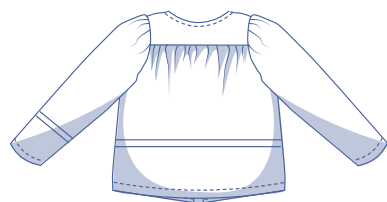

==== shorten or lengthen the pattern here

size	XS	S	M	L	XL	XXL	XXXL
length	60.25	62	63.75	65.5	67.75	70.25	72.5
sleeve length*	64	65.75	67.25	68.75	70.5	72	73.75
bust	119.25	129.25	139	148.75	160.75	174.75	188.5
hem circumference	103.5	113.25	122.75	132.25	144.25	158	171.75

* Including shoulder length.

Compare the stated lengths to the measured or desired lengths. **Lengthen** or **shorten** the blouse and/or the sleeves by cutting the pattern pieces at the indicated double lines. Then either increase the distance between the cut pieces by the desired amount (to lengthen) or overlap the pieces (to shorten). Make sure that the CF and CB lines and the side seams are always straight.



IMPORTANT

Adjust the amount of fabric to be used based on these alterations.

notions



- Thread
- Iron-on interfacing: max. 20 cm
- Buttons (Ø 1.1 cm): see table
- Fabric: see table

buttons	XS	S	M	L	XL	XXL	XXXL
	6	6	6	7	7	7	7

fabric		XS	S	M	L	XL	XXL	XXXL
fabric width 110 cm	cm	185	190	200	205	210	220	270
fabric width 140 cm	cm	155	155	165	190	195	205	210

The corresponding fabric layout can be found on page 6 of these sewing instructions.

fabric advice Ermine works well in all kinds of different fabrics, from drapery viscose (crepe), lycell, silk to somewhat stiffer fabrics like poplin, chambray, lace, and fine or baby wale corduroy. This pattern is a treat in solids and colourful prints alike. Wovens will produce the nicest result though given the blouse's delicate details.



Proud to be #Sewista

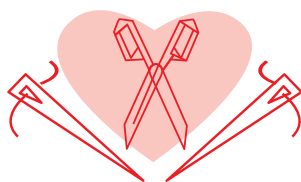

pattern pieces & seam allowances (in cm)

To sew the garment as described in the instructions, draw the illustrated seam allowances around the paper pattern pieces before cutting them out. If you are using a PDF pattern, the pattern can be printed with or without seam allowance.

To find out more, watch the [video](#).

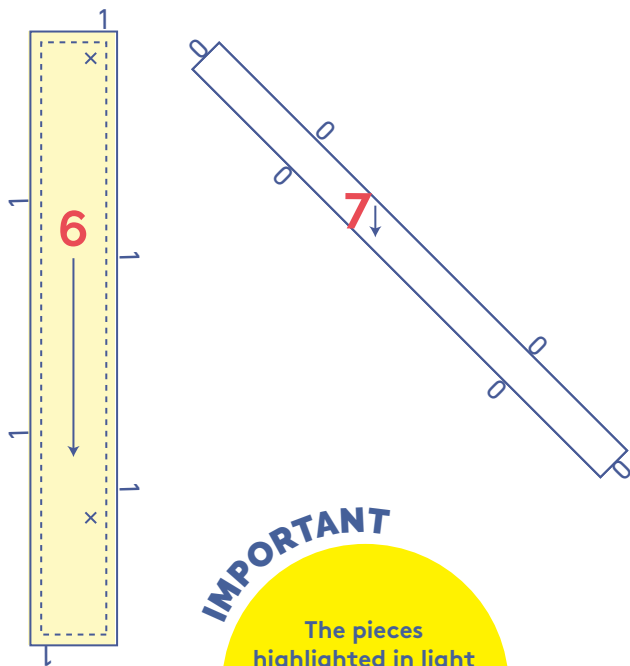
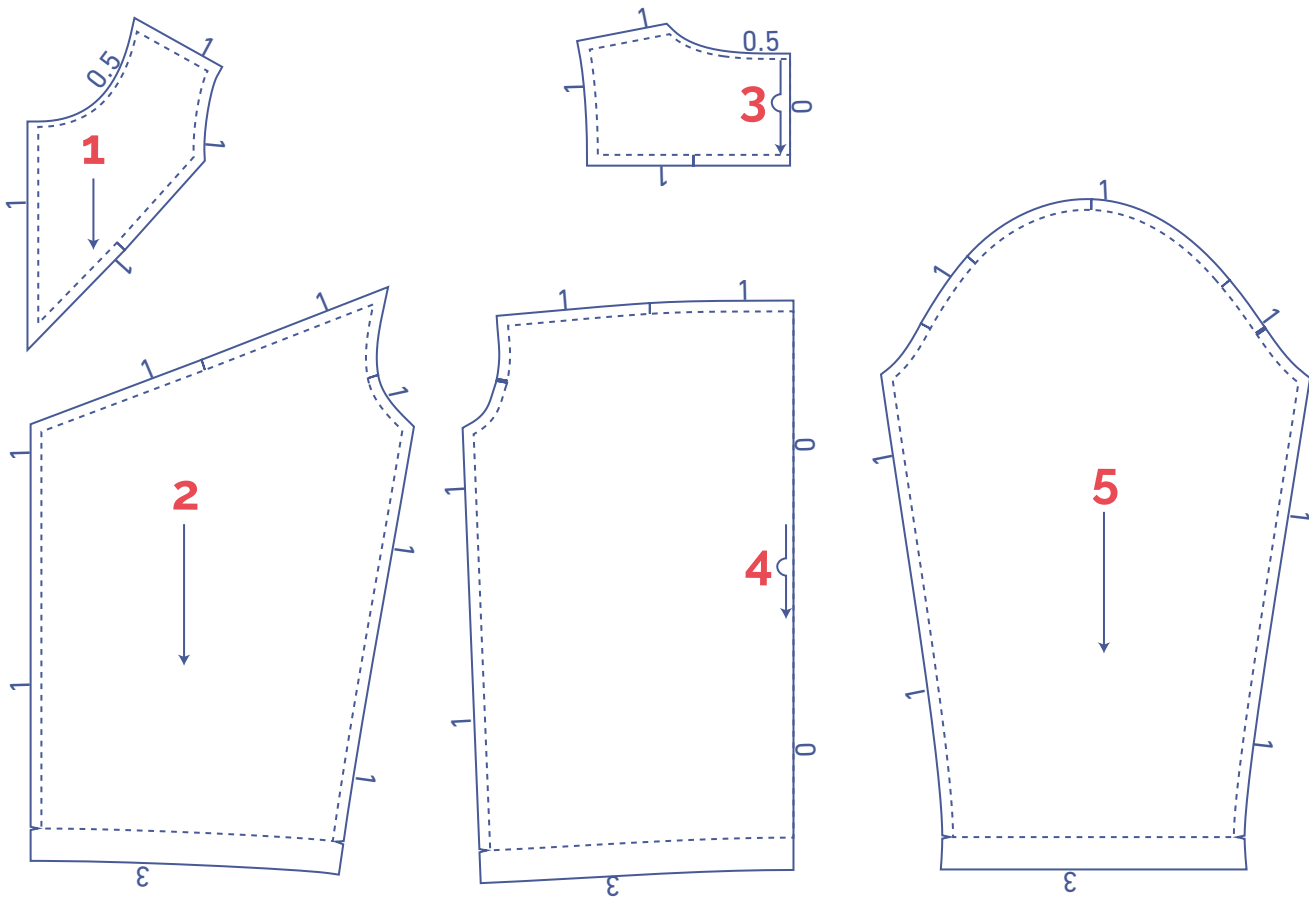

IMPORTANT

The pieces highlighted in light yellow have iron-on interfacing attached to the wrong side.

- 1. yoke front: 2x
- 2. front: 2x
- 3. yoke: 1x on fabric fold
- 4. back: 1x on fabric fold
- 5. sleeve: 2x
- 6. button placket: 2x
- 7. bias tape neck: 1x

 material type
<input type="checkbox"/> fabric
<input checked="" type="checkbox"/> iron-on interfacing

fabric layout - solid fabrics
fabric width 110 cm

XS - XXL

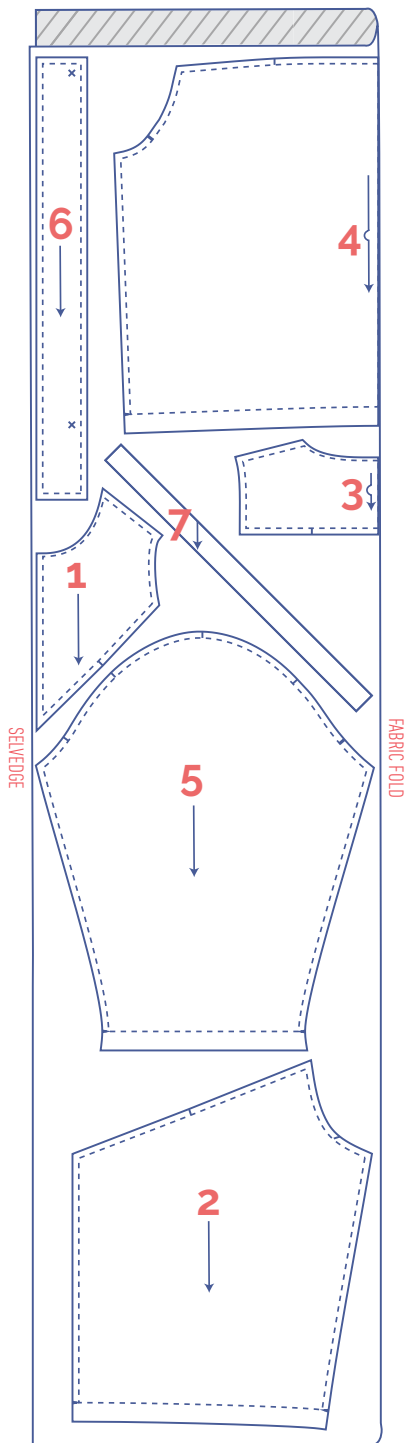

XXXL

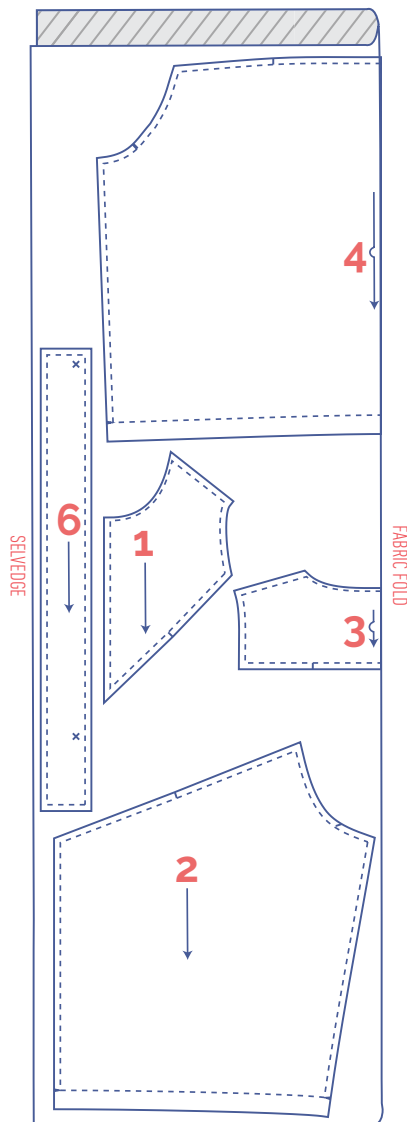

+

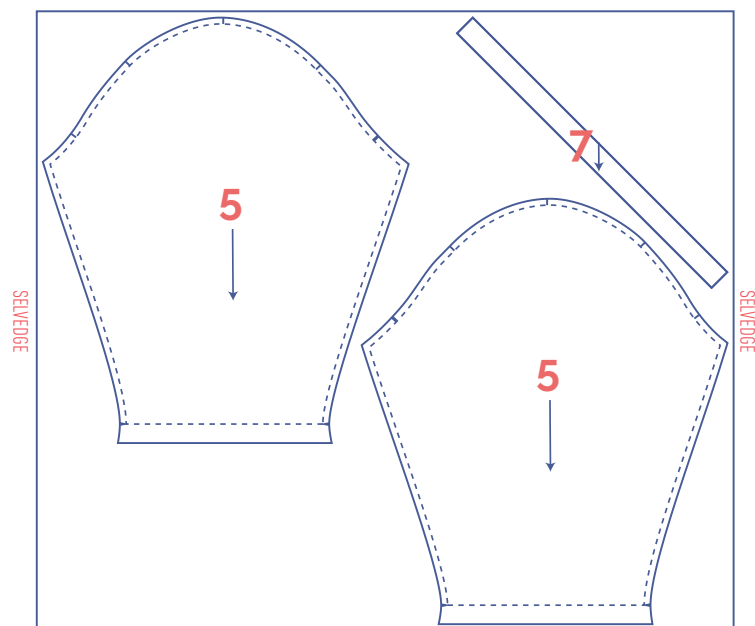

IMPORTANT

You only need pattern piece 7 once.

fabric layout – solid fabrics
fabric width 140 cm

XS - M

L - XXXL

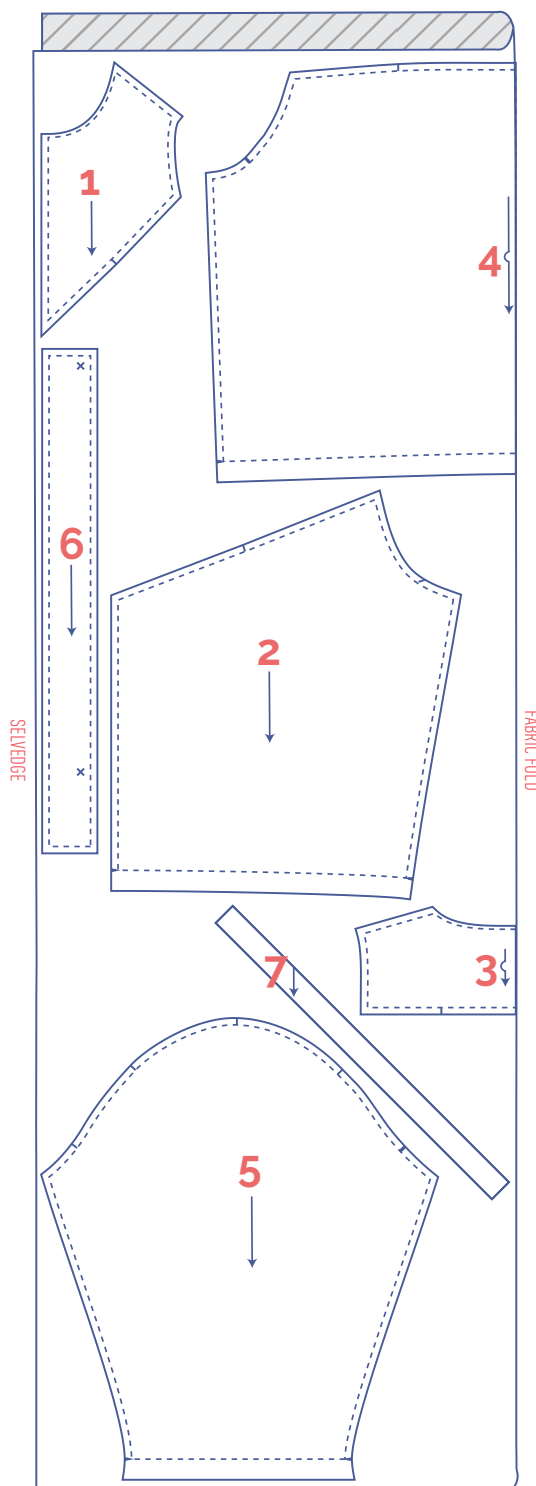
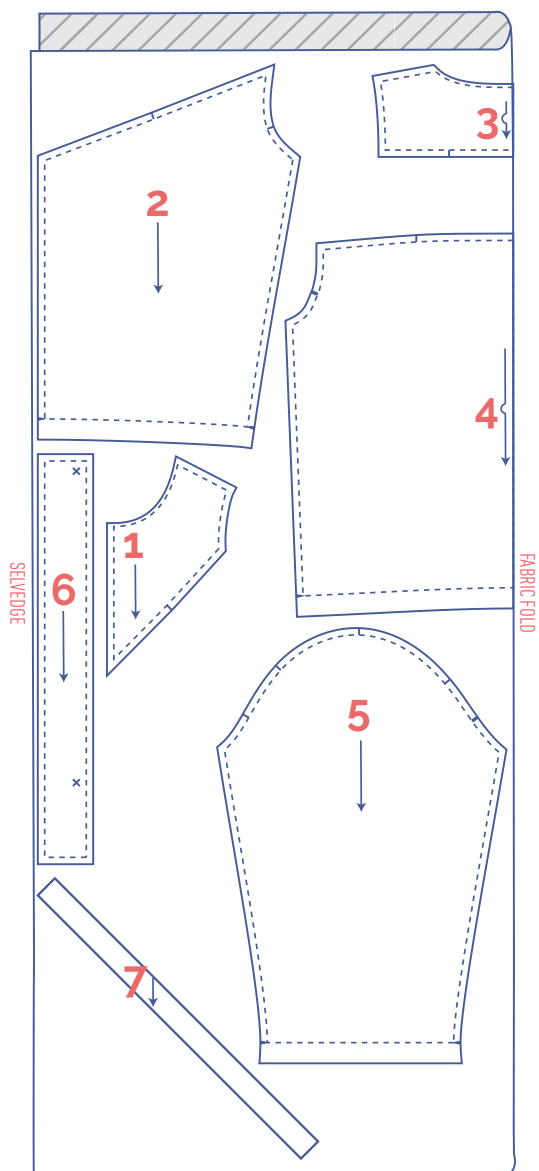

IMPORTANT



You only need pattern piece 7 once.

IMPORTANT

You only need pattern piece 7 once.

marking pattern pieces

	Notch the pattern paper and fabric at the following points
	single notch
	double notch
∨	V notch

	Mark the following points with marking thread
	buttons

sewing instructions



The method used to finish the seams depends on the fabric used.
The pieces are always sewn together with the right sides of the fabric facing, unless stated otherwise.

F front

B back

RF right front ●

LF left front ●

CF centre front

CB centre back

□ right side

▨ wrong side

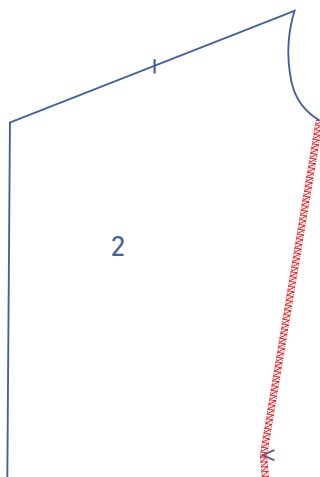
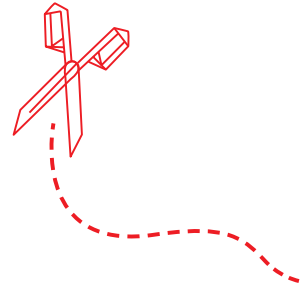

1

Finish the sides of the front (2) with overlock stitching.

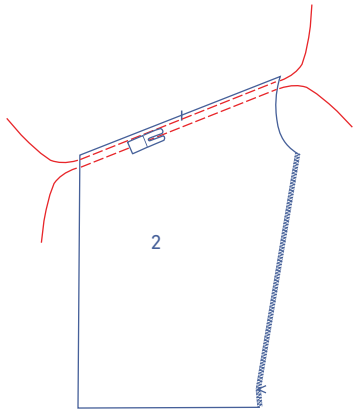

Sew 2 parallel lines of stitching at the top of the front, using a long stitch length at a low thread tension. Leave a length of thread at the start and end of the rows.

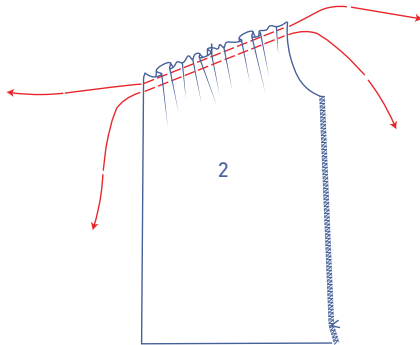

Carefully tug the ends of the threads to gather the fabric.

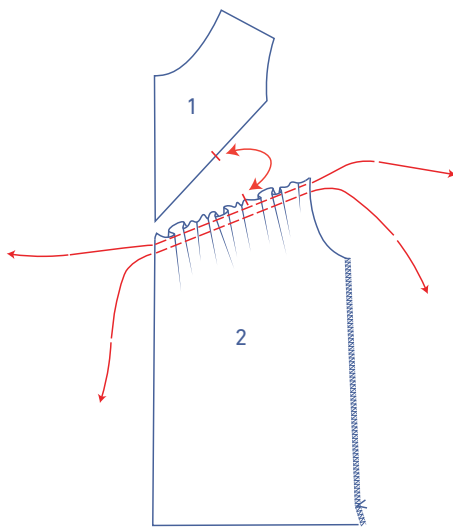

Distribute the gathers until the notches in the front match the notches in the yoke front (1).

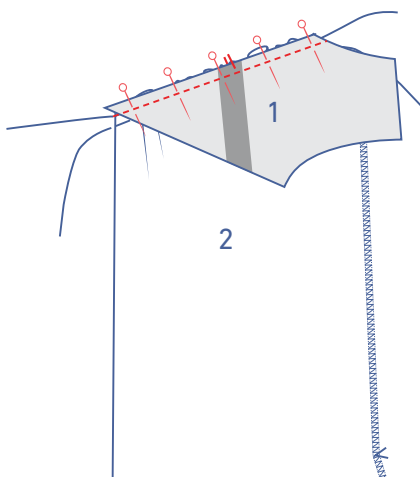

Pin and sew the front to the yoke, matching the notches.

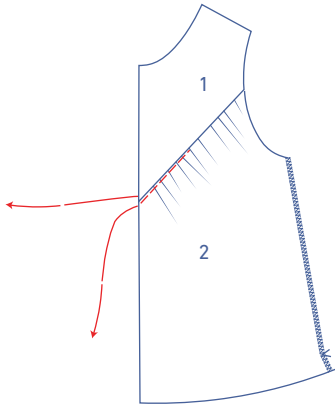

Remove the gathering threads.

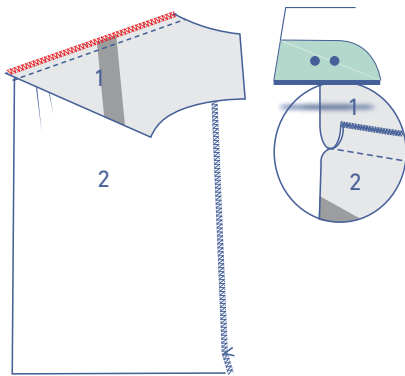

Finish the raw edges together with overlock stitching and press the seam allowance towards the yoke.

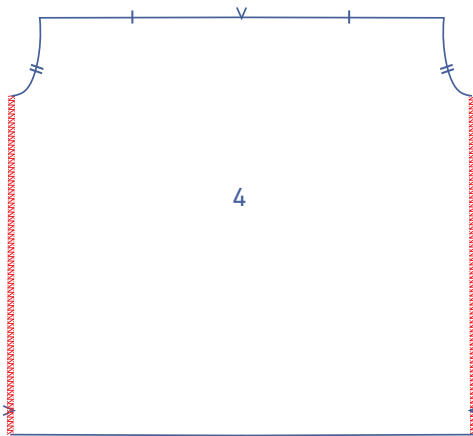

2

Finish the sides of the back (4) with overlock stitching.

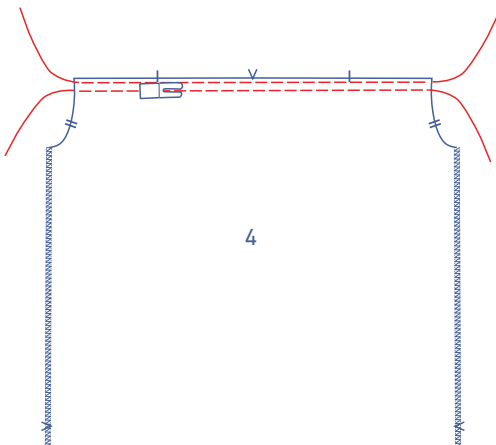

Sew 2 parallel lines of stitching at the top of the back, using a long stitch length at a low thread tension. Leave a length of thread at the start and end of the rows.

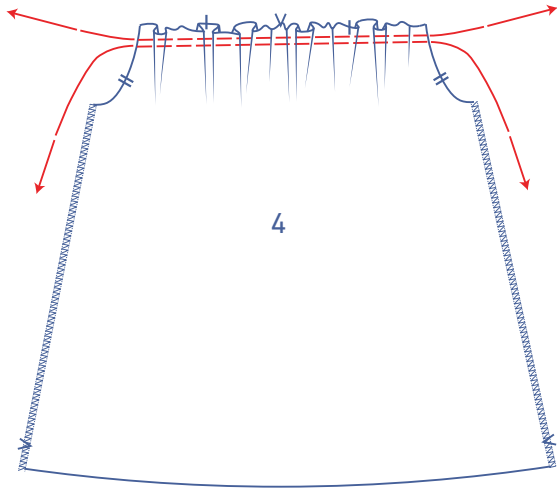

Carefully tug the ends of the threads to gather the fabric.

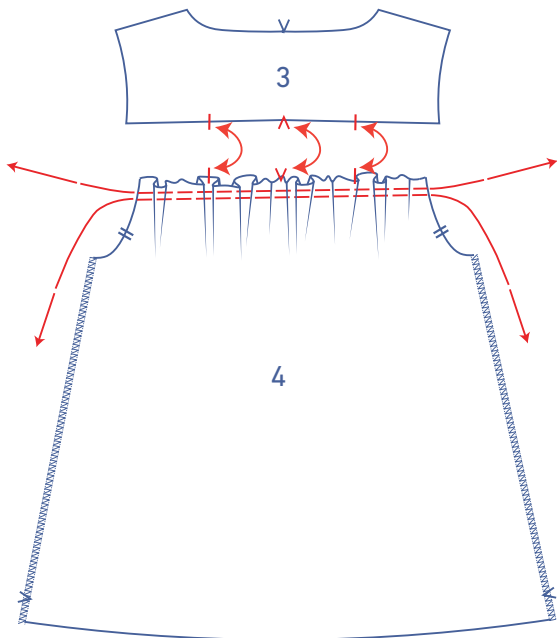

Distribute the gathers so that the notches in the back match the notches in the yoke (3).

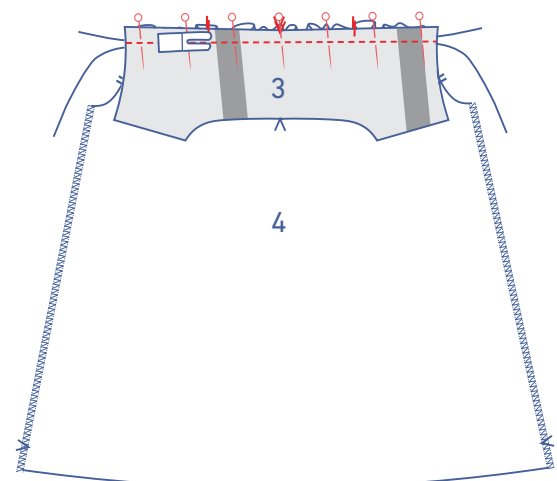

Pin and sew the back to the yoke, matching the notches.

Next, remove the gathering threads.

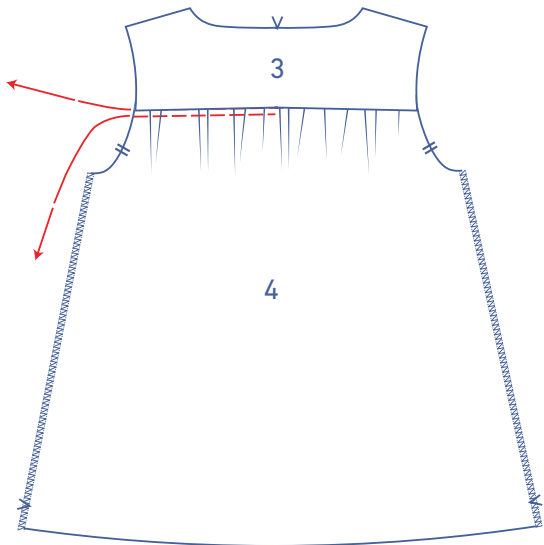

Finish the raw edges together with overlock stitching and press the seam allowance towards the yoke.

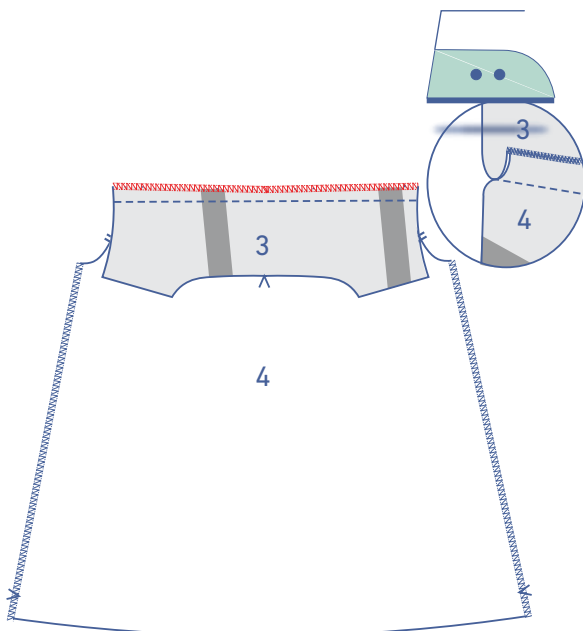

3

Pin and stitch the shoulder seams.

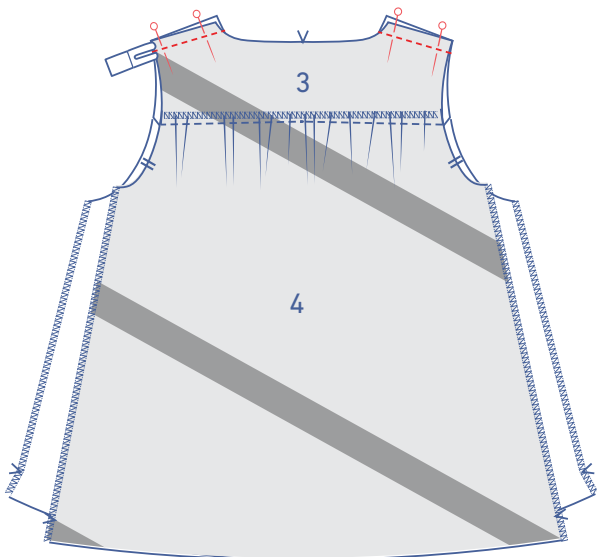

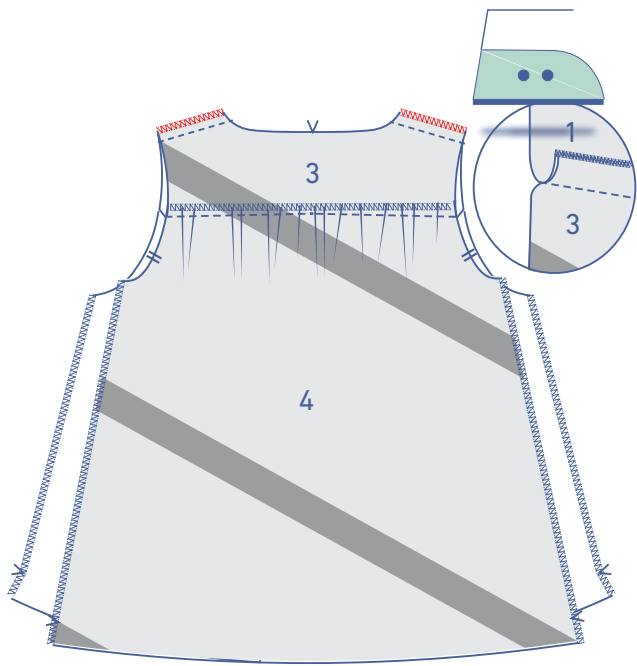

Finish the raw edges together with overlock stitching and press the seam allowance towards the front yoke.

4

Fold the bias tape (7) in half with the long ends touching and the wrong sides of the bias tape facing.



Pin the raw edges of the bias tape to the right side of the neckline. The raw edges of the bias tape should line up with the raw edge of the CF.

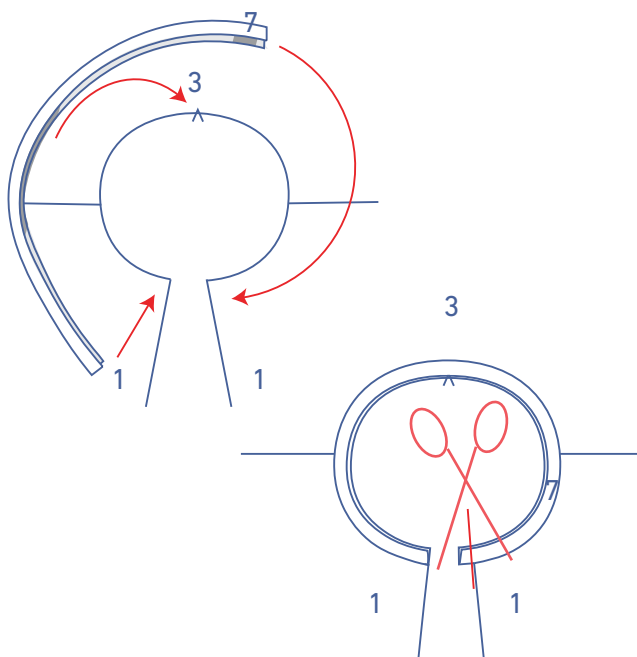

Trim any excess bias tape (as every fabric behaves a little differently on the bias, you may end up with a little excess needing trimming).

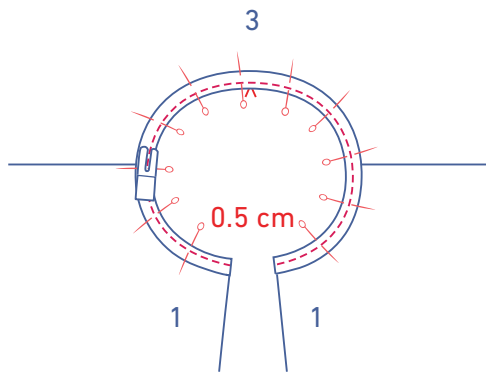

Sew the bias tape into place at 0.5 cm from the neckline.

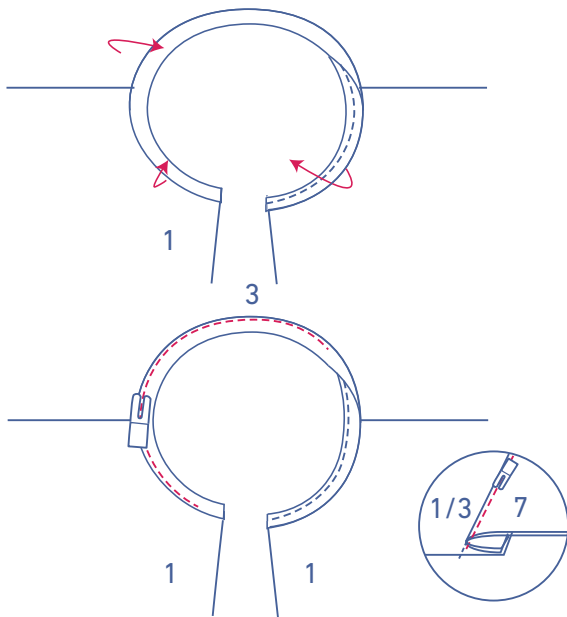

Fold the bias tape over and stitch to the seam allowance underneath, right next to the seam.

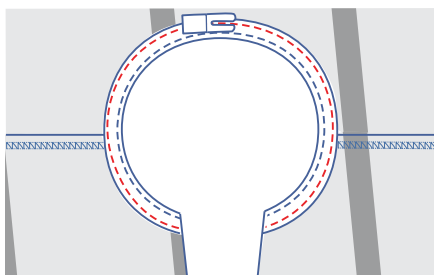

Now, fold the bias tape over towards the wrong side and stitch into place right next to the edge.

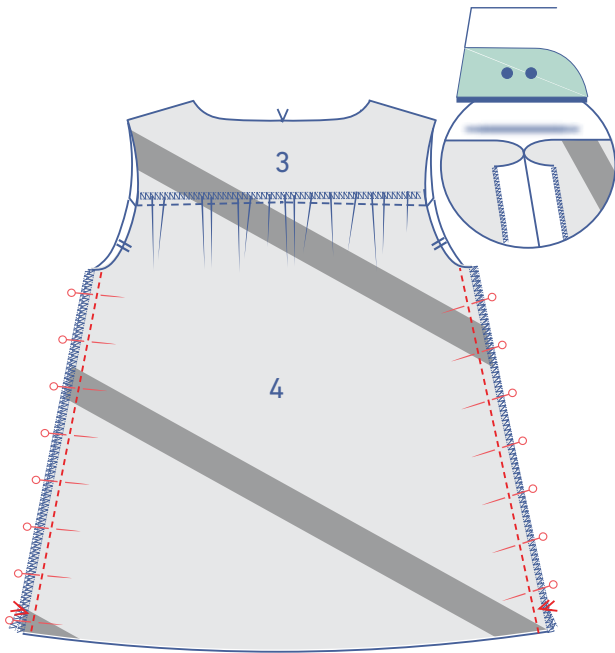

5

Pin and sew the side seams together. Press the seam allowance open.

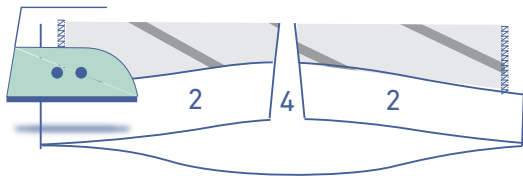

Press the hem allowance towards the wrong side at the V notch and open back out.

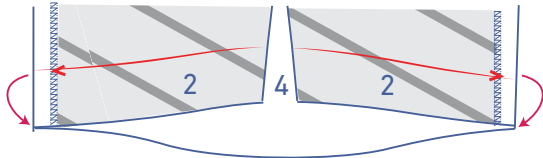

Fold the raw edge up to meet the pressed fold line and fold over again.

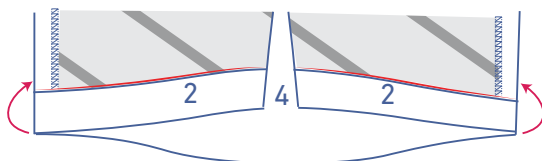
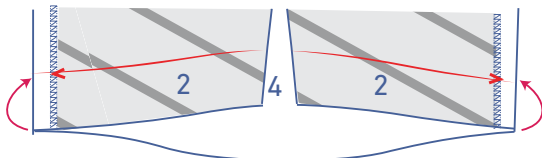

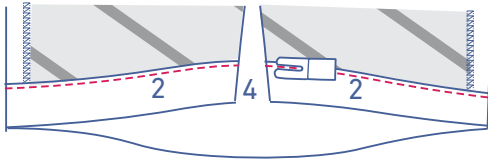

Edgestitch the hem allowance all the way around.

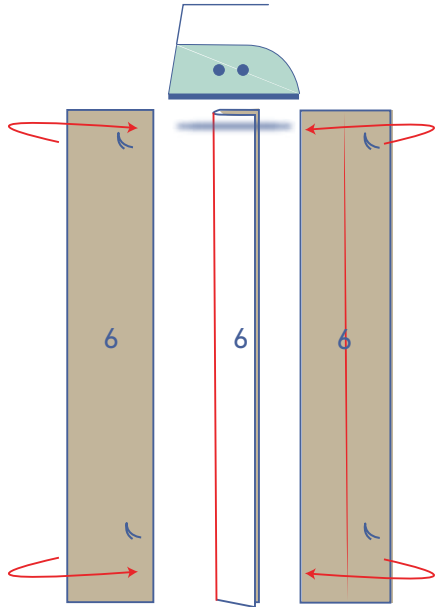

7

Fold the button placket (6) in half with the long ends touching and the wrong sides of the fabric facing to create a fold line. Open back out.

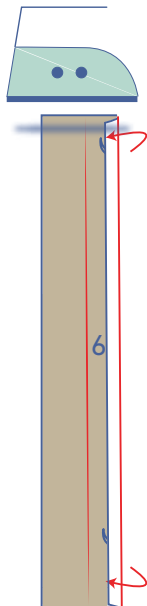

Press the long end (the one closer to the marking thread) 1 cm over towards the wrong side.

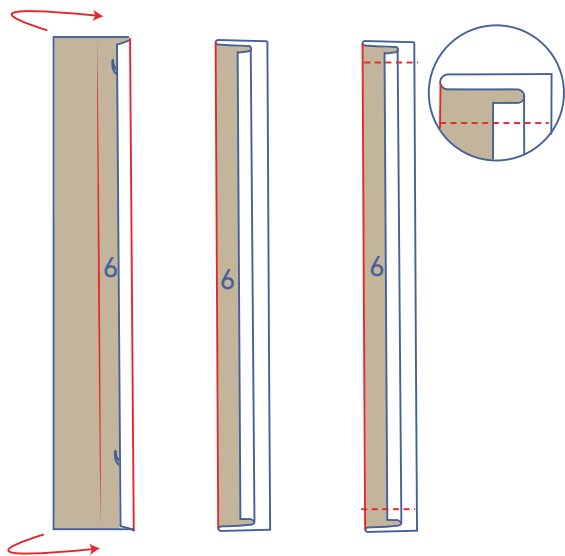

Fold the button placket in half along the pressed fold line with the right sides of the fabric facing. Sew the short ends.

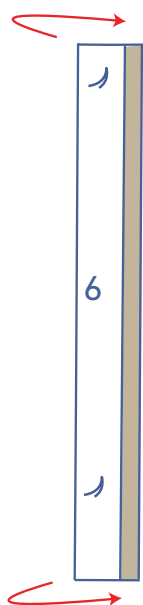

Turn the button placket the right way out.

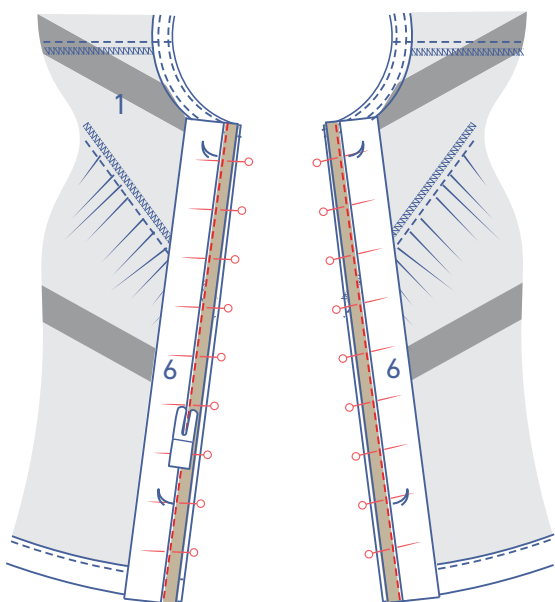

Pin the unpressed raw edge of the button placket to the CF on the wrong side of the garment. The finished top of the button placket should be with the 'finished neckline', and the finished bottom is level with the finished hem. Stitch into place.

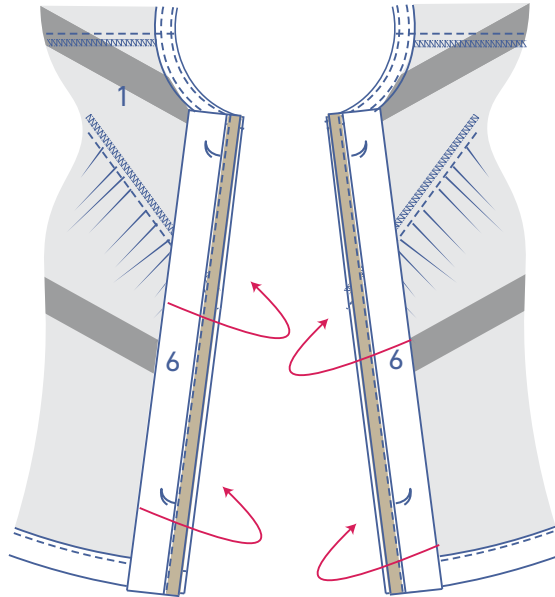

Turn the button placket over onto the right side of the garment.

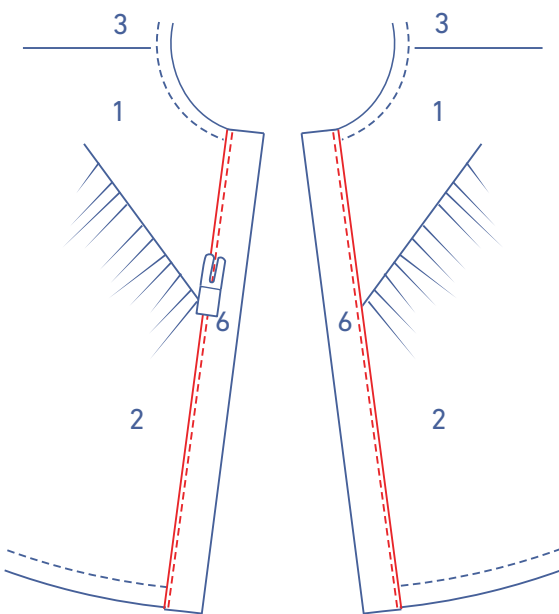

Place the fold line directly over the stitching. Edge stitch into place.

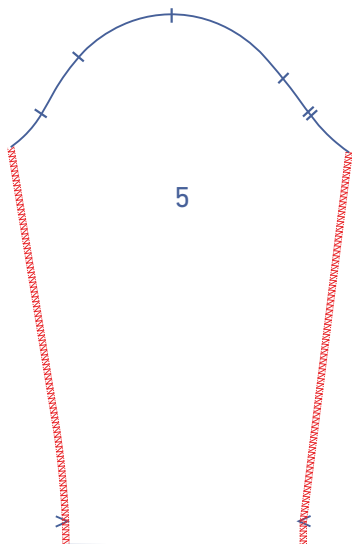

8

Finish the sleeve sides (5) with overlock stitching.

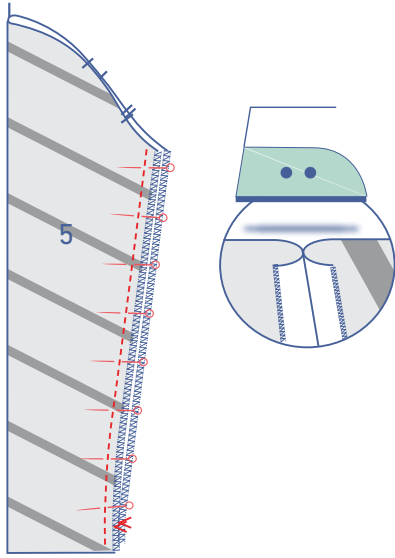

Pin and sew the underarm seam. Press the seam allowance open.

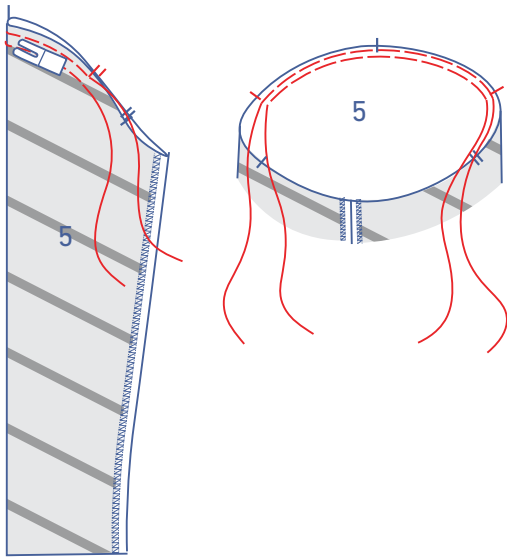

Using a long stitching length at a low thread tension, sew two lines of parallel stitching at the top of the sleeve until just past the indicated single notches on either side of the top notch. Leave a length of thread at the start and end of the rows.

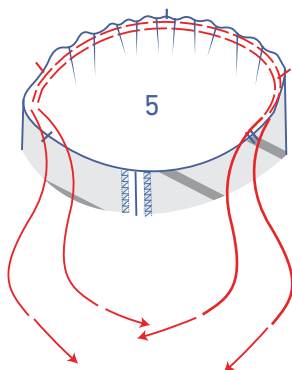

Carefully tug the ends of the threads to gather the fabric.

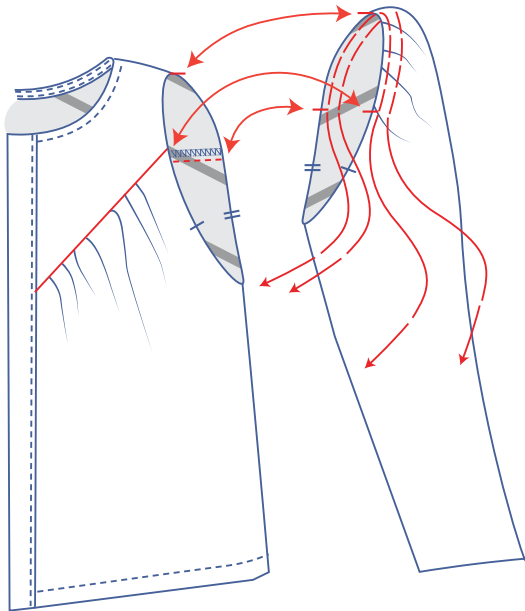

Distribute the gathers so that the sleeve notches match the armhole notches indicated on the front and back.

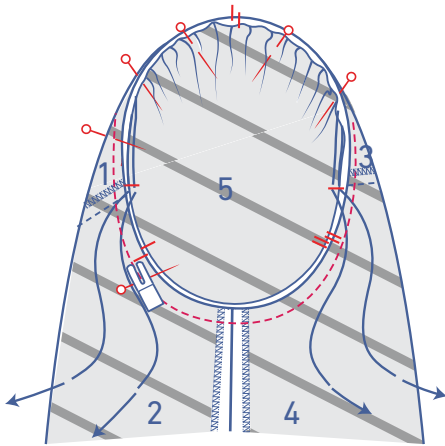

Pin and sew the top of the sleeve (= sleeve cap) to the armhole, matching the notches. The single notch marks the front, while the double notch marks the back. The single notch at the top aligns with the shoulder seam. Distribute the 'excess' fabric evenly between the other single notches.

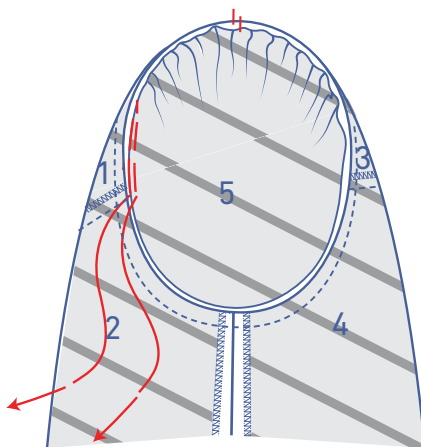

Remove the gathering threads.

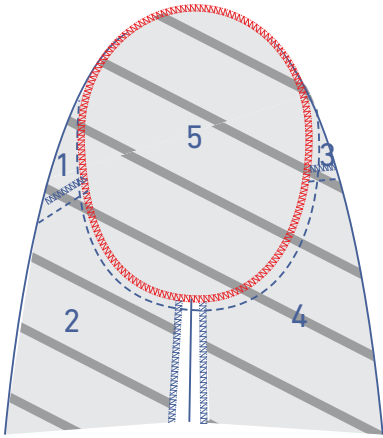

Finish the raw edges with overlock stitching.

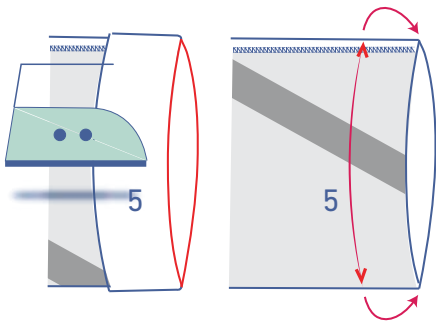

Press the hem allowance of the sleeve towards the wrong and open back out.

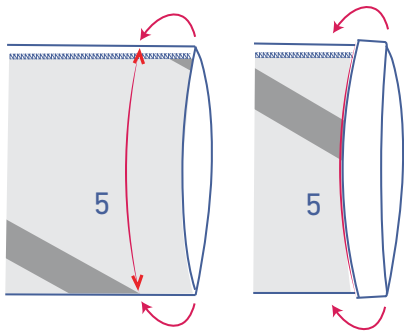

Match the raw edge to the pressed fold line and fold again on the pressed fold line.

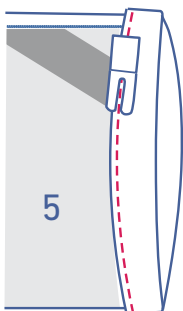

Edgestitch into place.

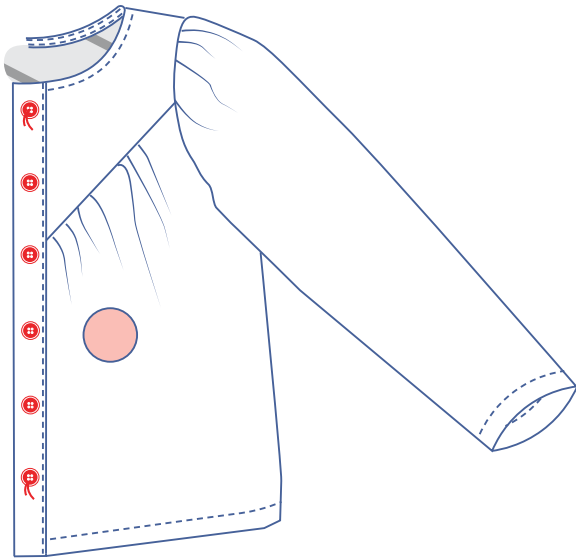

9

Sew the buttons onto the LF where indicated. The top and bottom button have been marked on the pattern. Divide the distance between these buttons evenly to determine the location of the other buttons.

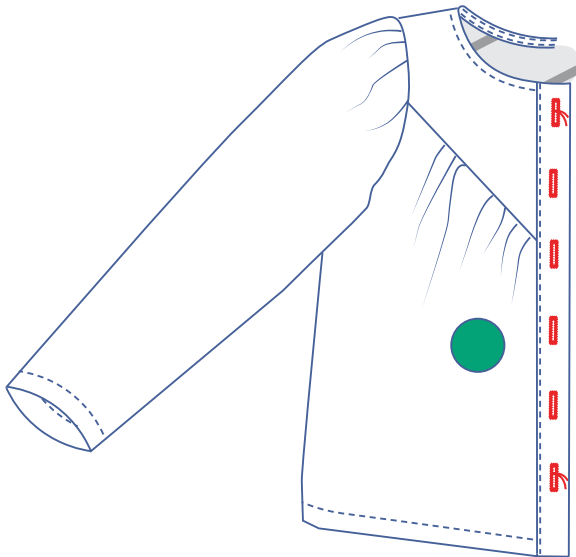

Make vertical buttonholes in the RF to match the buttons.