

# Elaine by Fibre ⚡ood



# Elaine by Fibre ⚡ood



**XS - XXXL**

You can never go wrong with a jumper. Elaine is entrancingly minimalist. But the select, sophisticated details make it shine – shaped sleeves that balloon ever so slightly, contoured darts in the sleeve hem, an elegant V keyhole neckline, and a relaxed ribbed trim hem band. It's a must!

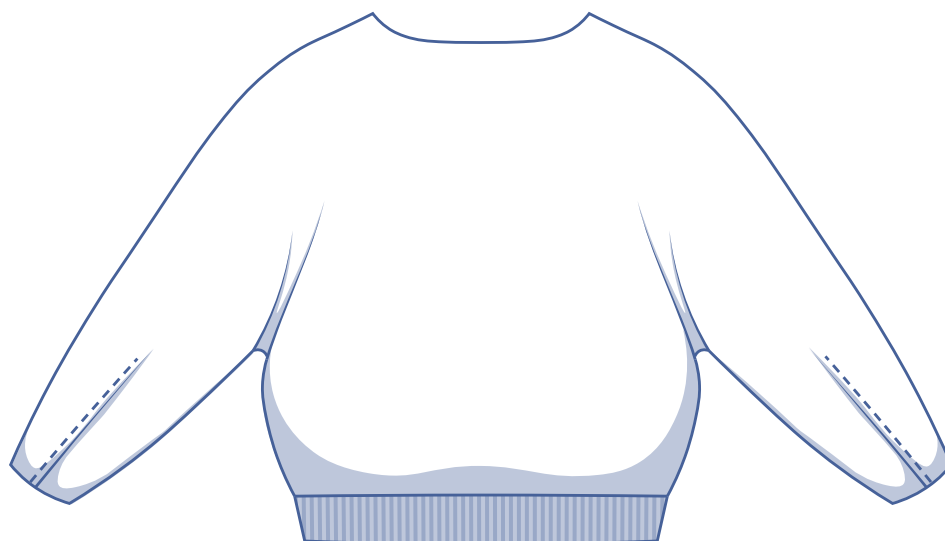
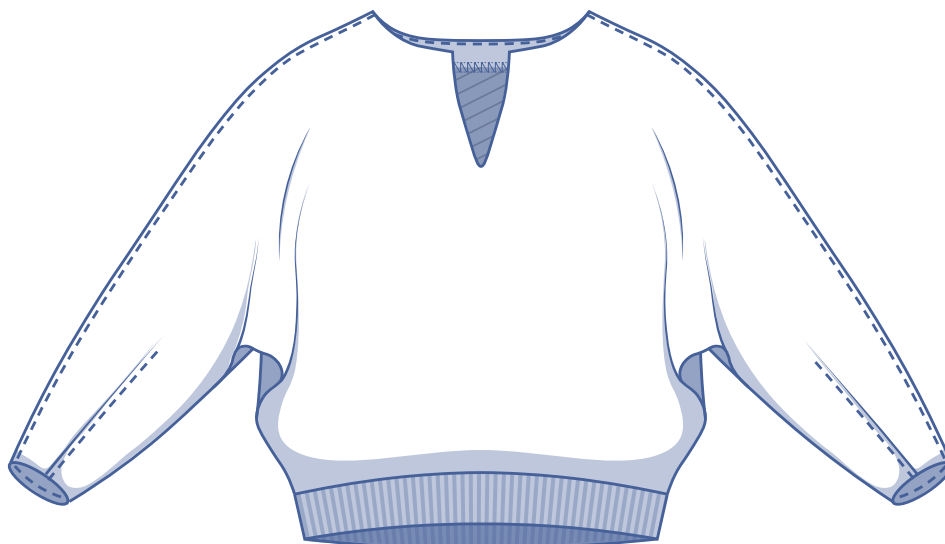

## size chart (in inches)

size	XS		S		M		L		XL		XXL		XXXL		
	0	2	4	6	8	10	12	14	16	18	20	22	24	26	28
body height	5' 25"	5' 38"	5' 45"	5' 48"	5' 51"	5' 54"	5' 58"	5' 61"	5' 64"	5' 64"	5' 64"	5' 64"	5' 64"	5' 64"	5' 64"
B (bust)	29.9	31.5	33.1	34.6	36.2	37.8	39.4	40.9	43.3	45.7	48	50.4	52.8	55.1	57.5

Choose your size based on your **bust measurement**. Pick the size that is the best match for your bust.

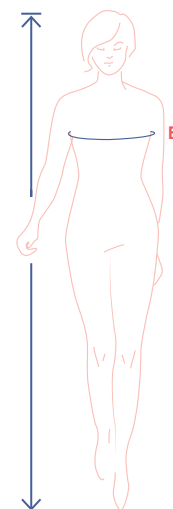

## pattern measurements (in inches)

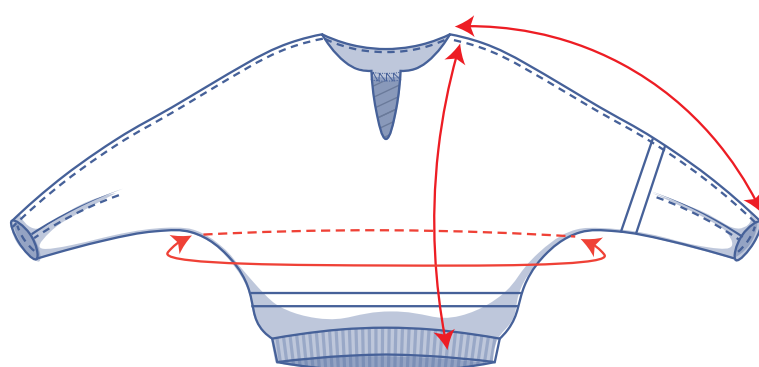

This chart's measurements are the pattern measurements based on the fabric type and serve as a reference. Elaine is designed to have an **oversized cut**, so ease has been added to the width measurements (in addition to the exact body measurements).

Not a big fan of oversized items?  
Just go a size smaller.

== shorten or lengthen the pattern here

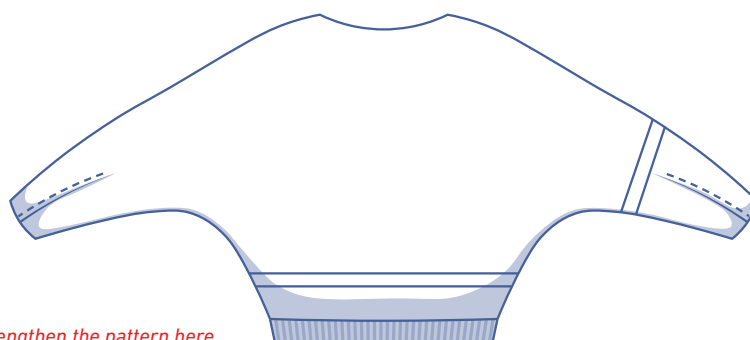

size	XS	S	M	L	XL	XXL	XXXL
length*	22.9	23.7	24.4	25.1	26	26.9	27.8
sleeve length**	24.4	25	25.6	26.3	26.9	27.6	28.3
bust	48.5	51.6	54.8	57.9	61.9	66.6	71.3

\* Including the hem band.

\*\* Including the shoulder length.

Compare the stated lengths to the measured or desired lengths. **Lengthen** or **shorten** the sweatshirt and/or sleeves by cutting the pattern pieces at the indicated double lines. Then either increase the distance between the cut pieces by the desired amount (to lengthen), or overlap the pieces (to shorten). Make sure that the CF and CB lines and the side seams are always straight.



### IMPORTANT

Adjust the amount of fabric to be used based on these alterations.

## notions



- Thread
- Trim fabric (width 14"): max. 12"
- Fabric: see table

fabric use		XS	S	M	L	XL	XXL	XXXL
fabric width 43"	yd	2 ½	2 ½	2 ¾	2 ¾	3	3	3 ¼
fabric width 55"	yd	1 ¾	1 ¾	2	2 ¼	2 ¼	2 ¼	2 ¼

The corresponding fabric layout can be found on page 6 of these sewing instructions.

**fabric advice** Elaine looks best in a knit fabric. So, you've got no shortage of options with sweatshirt fabric, French terry, scuba, interlock, knit jacquard, and more!



# Proud to be #Sewista

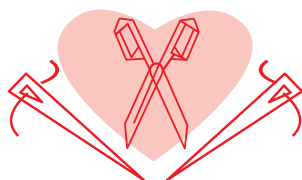





## pattern pieces & seam allowances (in inches)

To sew the garment as described in the instructions, draw the illustrated seam allowances around the paper pattern pieces before cutting them out. If you are using a PDF pattern, the pattern can be printed with or without seam allowance.

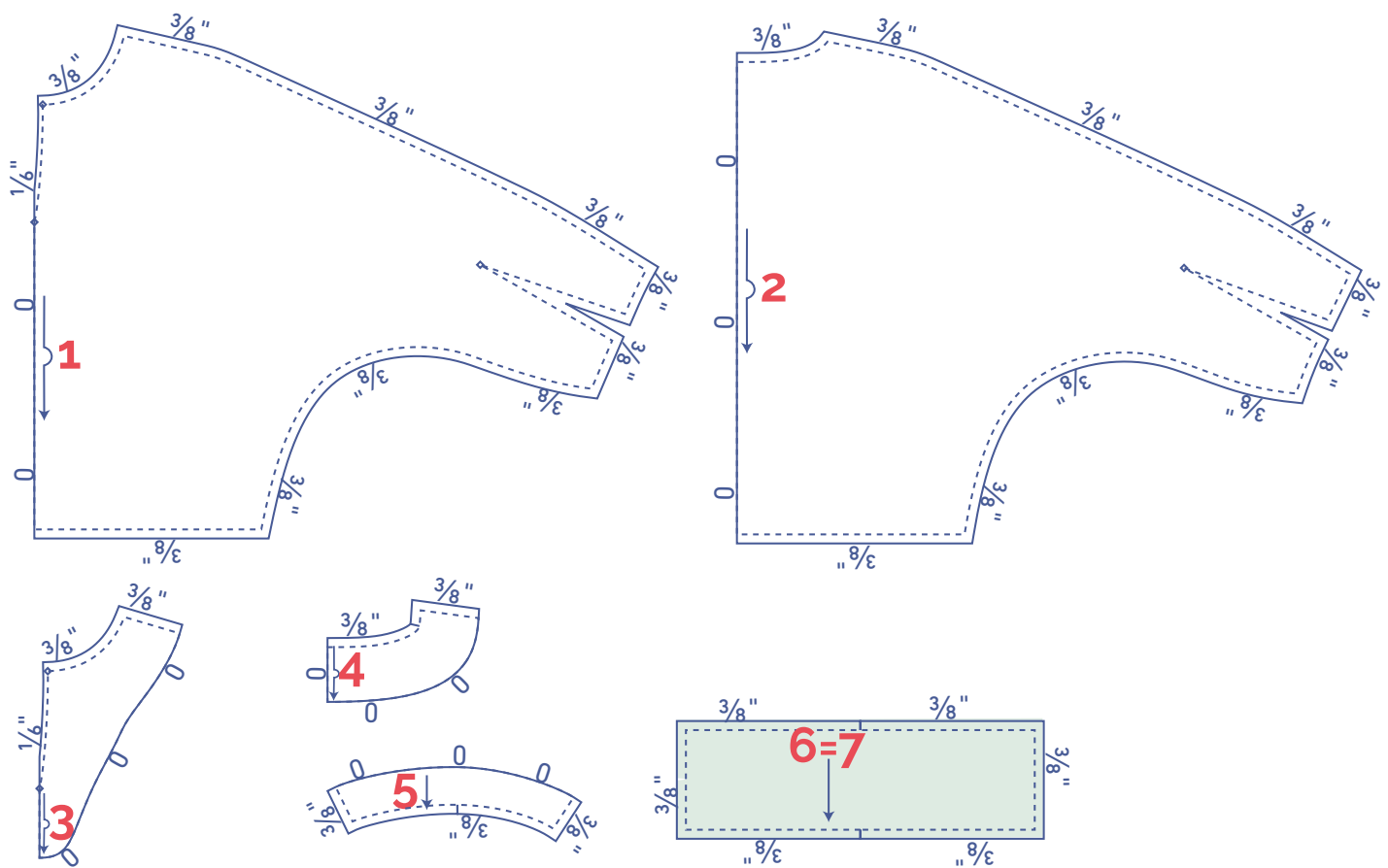
To find out more, watch the [video](#).

1. front: 1x on fabric fold
2. back: 1x on fabric fold
3. facing front: 1x on fabric fold
4. facing back: 1x on fabric fold
5. sleeve facing: 2x
6. hem band front: 1x
7. hem band back: 1x



	material type
	fabric
	trim fabric

### IMPORTANT

Pattern pieces 6 and 7 are the same.

# fabric layout – solid fabrics fabric width 43"

XS - XXXL

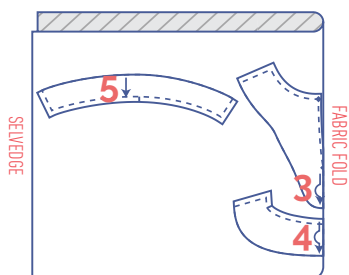

+

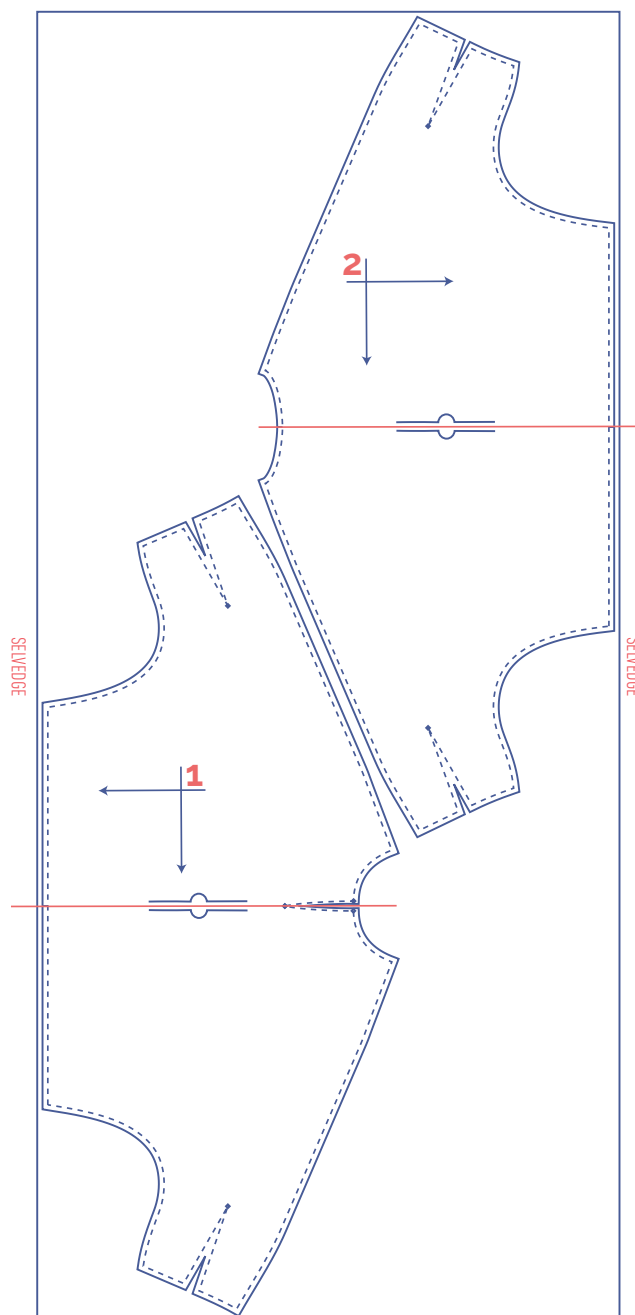

## IMPORTANT

Pattern pieces 1 and 2 have been rotated at a 90° angle to fit the fabric width. Bear this in mind if you are working with a patterned or napped fabric or if it has horizontal stretch.

# fabric layout – solid fabrics

## fabric width 55"

XS - S

M - XXXL

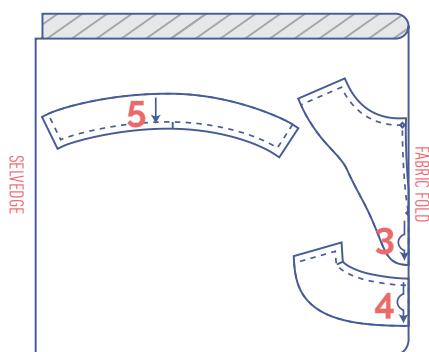
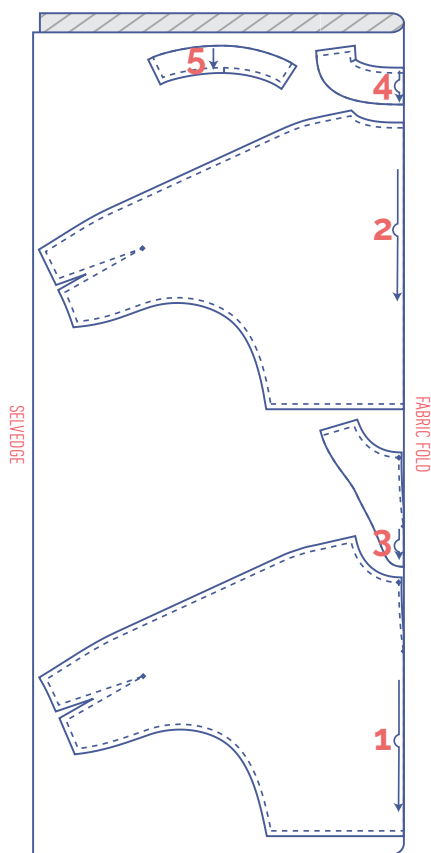

+

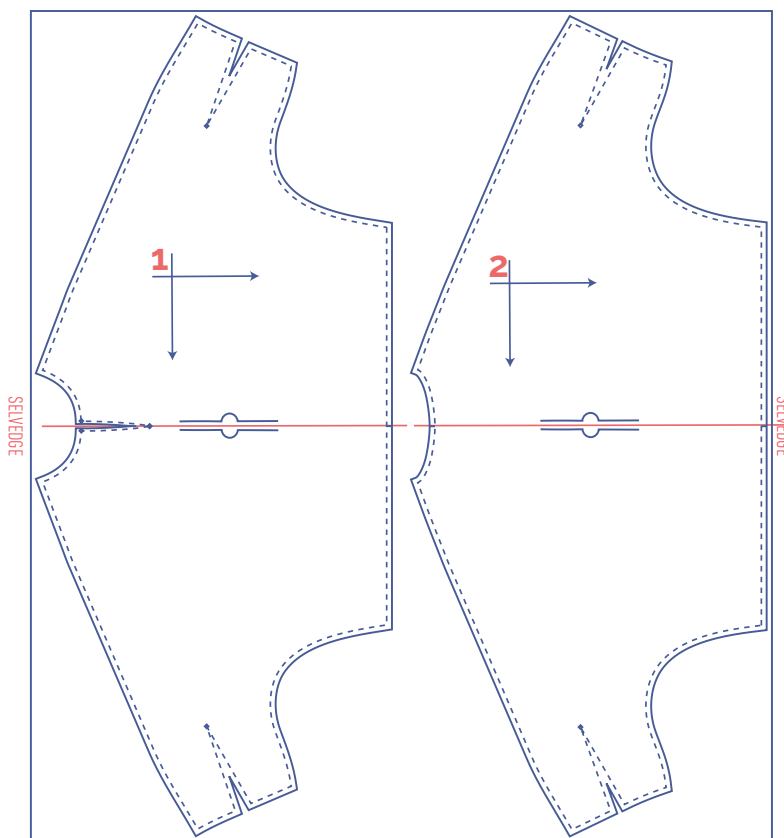

### marking pattern pieces



Notch the pattern paper and fabric at the following points

| single notch

V V-notch/fabric fold



Mark the following centre points with marking thread



centre point

### IMPORTANT

Pattern pieces 1 and 2 have been rotated at a 90° angle to fit the fabric width. Bear this in mind if you are working with a patterned or napped fabric or if it has horizontal stretch.

# sewing instructions



The sewing instructions explain how to make the jumper if you don't have an overlocker. Select a stretch stitch on your sewing machine to sew the seams and an overlock stitch to finish the raw edges. However, the jumper can also be sewn with a four-thread overlocker, i.e. two upper looper threads and two lower looper threads. The raw edges and seams are sewn together at the same time, which keeps the seams stretchy. Topstitching should be done with your normal sewing machine.



F front

B back

 right side

 wrong side

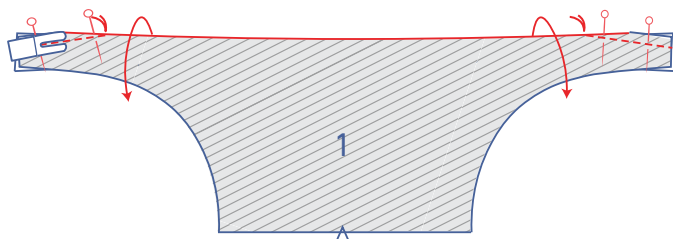

**1**

Fold the sleeve of the front (1) in half with the right sides of the fabric touching. Pin and sew the dart together as shown up to the marking thread.

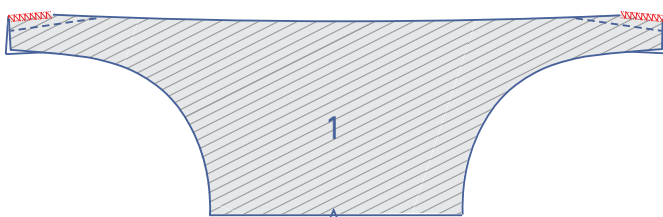

Finish the raw edges with overlock stitching.



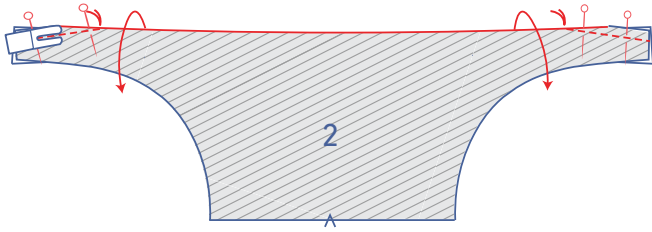

Repeat the previous steps for the back (2).

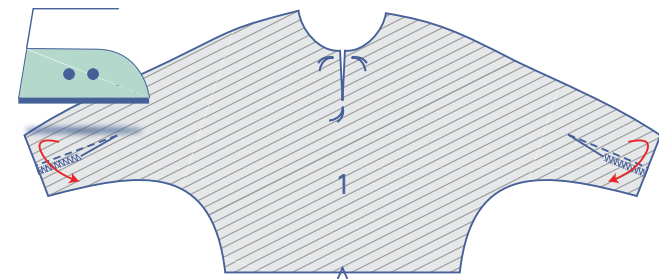
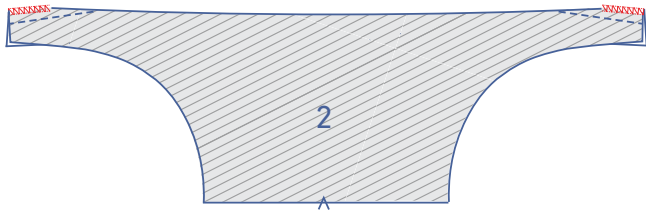

At the front, press the dart down towards the underarm seam. At the back, press the dart up towards the shoulder seam.

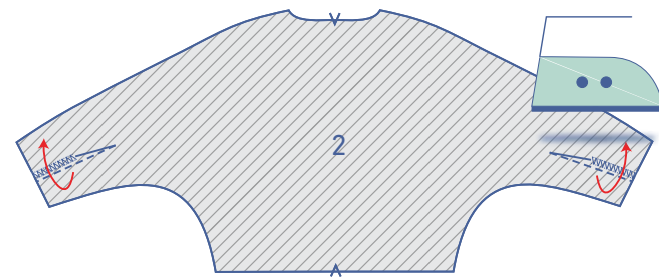

Topstitch each of the darts at presser foot width from the seam.

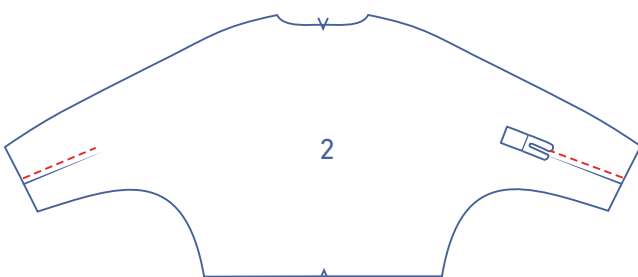
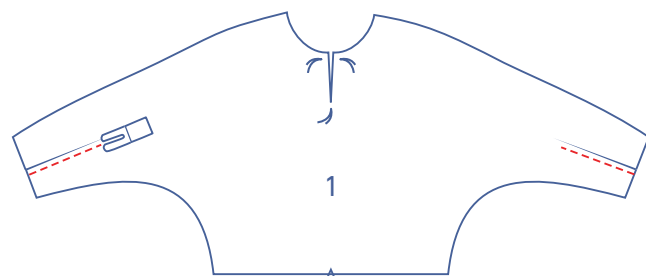

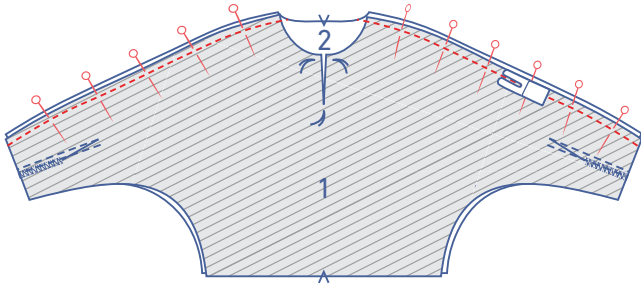

**2**

Pin and sew the shoulder seams together.

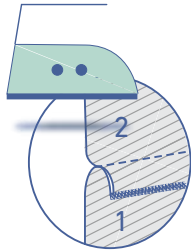

Finish the raw edges with overlock stitching. Press the seam allowance towards the front.

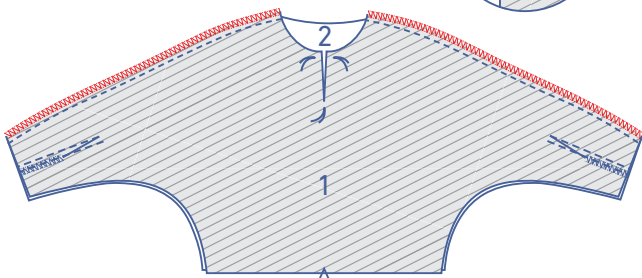

Topstitch the front at presser foot width from the seam.

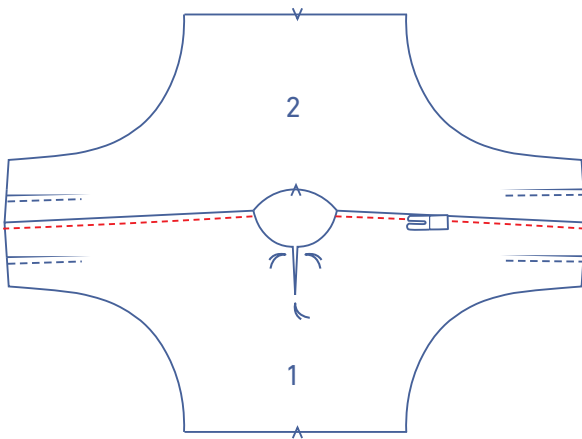

**3**

Pin and sew the shoulder seams of the facing front (3) and facing back (4).

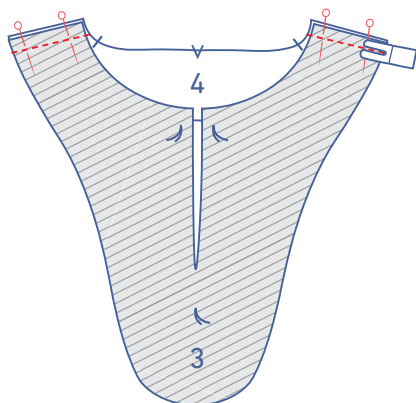

Finish the raw edges with overlock stitching. Press the seam allowance towards the back facing.

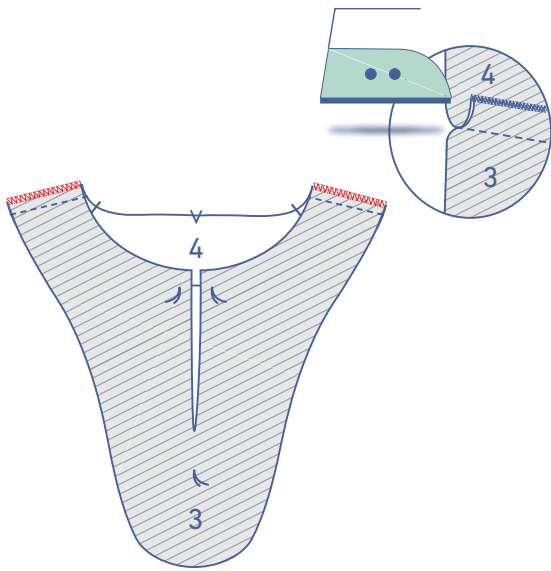

Topstitch the back facing at presser foot width from the seam.

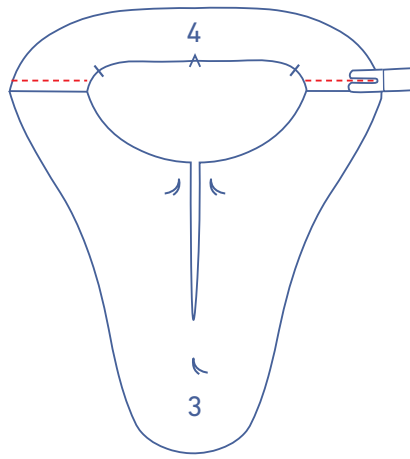

Finish the outer edge of the facing with overlocking.

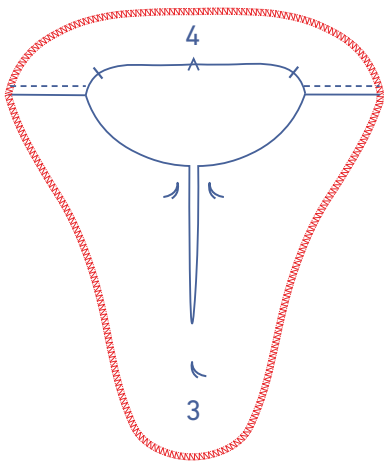

Pin the facing to the neckline with the markings matching. Note: the shoulder seams do not match. This is deliberate to avoid bulk at the shoulders. Start sewing at 1/6" from the raw edge at the marking thread in the corner at the top of the neckline keyhole. Sew to the tip of the keyhole. Leave the needle in the fabric.

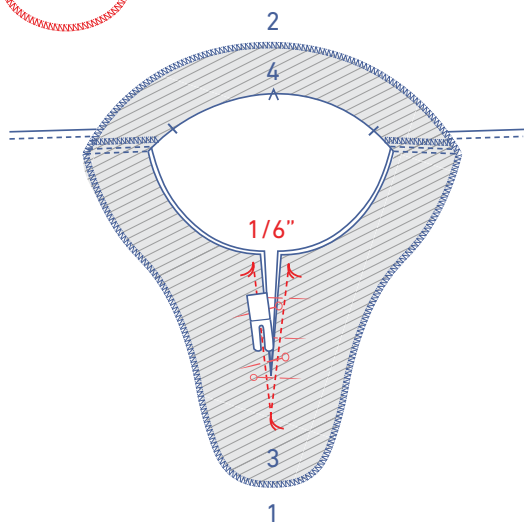

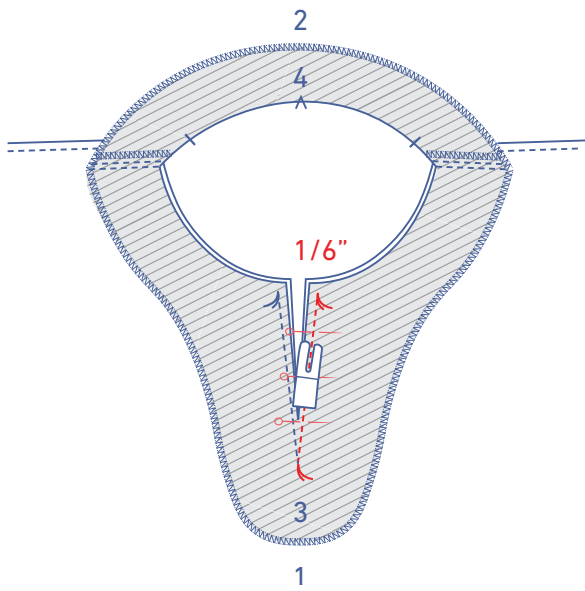

Lift the presser foot and pivot the garment. Continue sewing up to the marking thread in the other corner at the top of the neckline keyhole, ending again at 1/6 " from the seam allowance. Leave the needle in the fabric again.

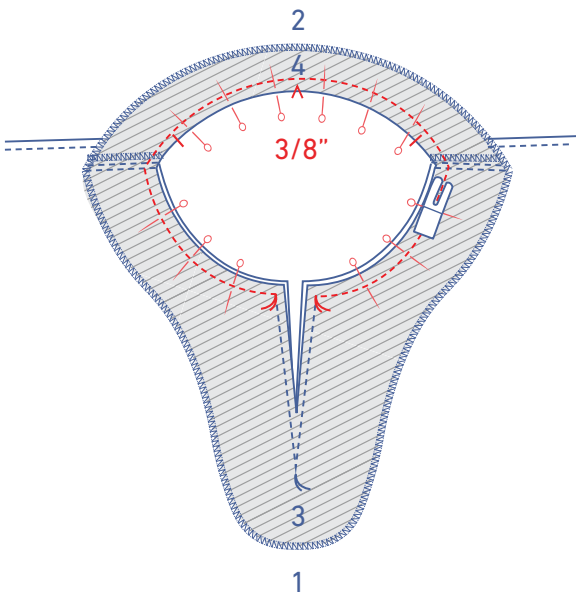

Pin and sew the rest of the neckline at 3/8 " from the raw edge.

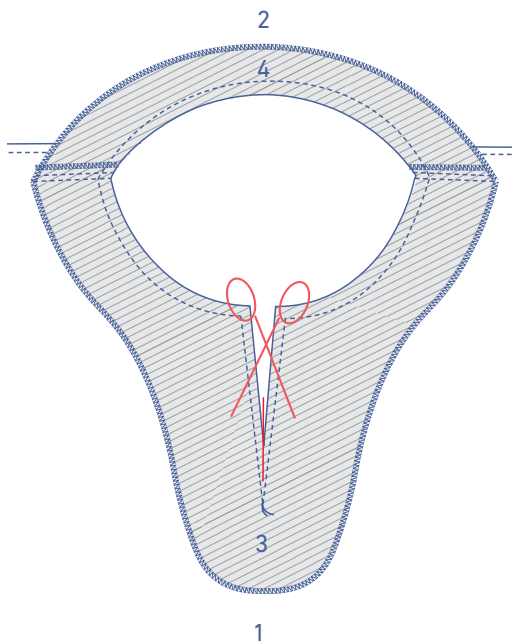

Snip into the seam allowance of the front and front facing until just before the marking thread.

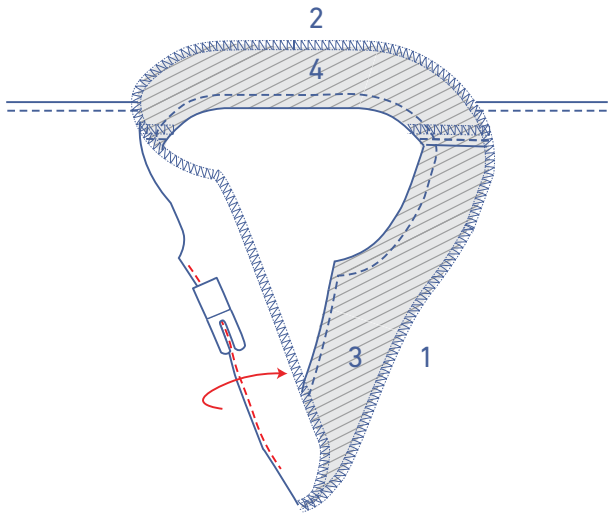

Fold the facing and seam allowance over. Sew the facing all the way around to the seam allowance underneath, right next to the seam. Sew as far as possible at the keyhole opening.

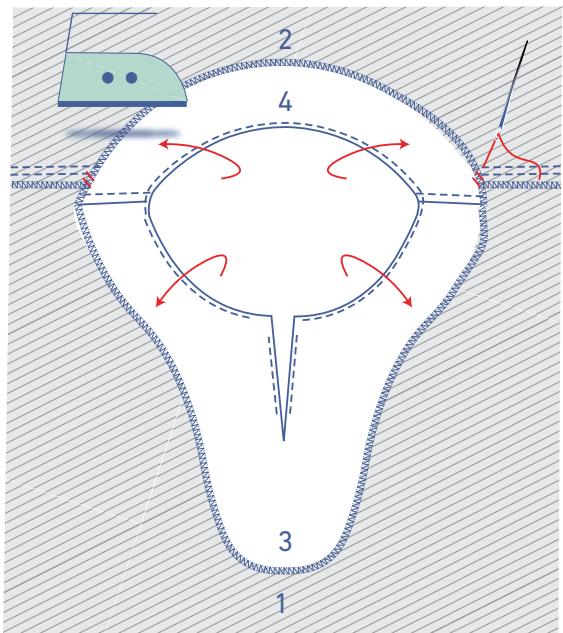
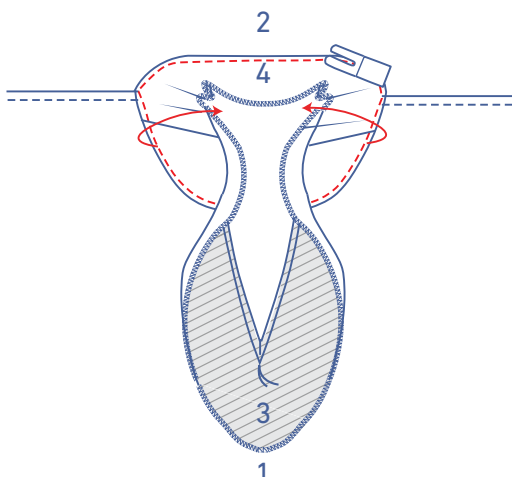

Press the facing neatly towards the wrong side and secure the facing to the shoulder seams with just a few stitches.

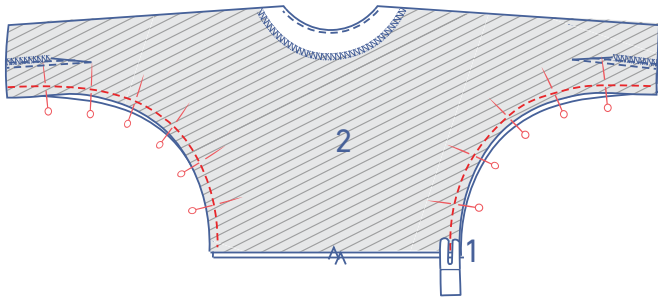

**4**

Pin and sew the side and underarm seams.

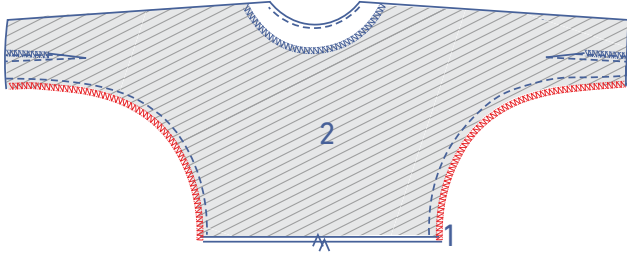

Finish the raw edges with overlock stitching.

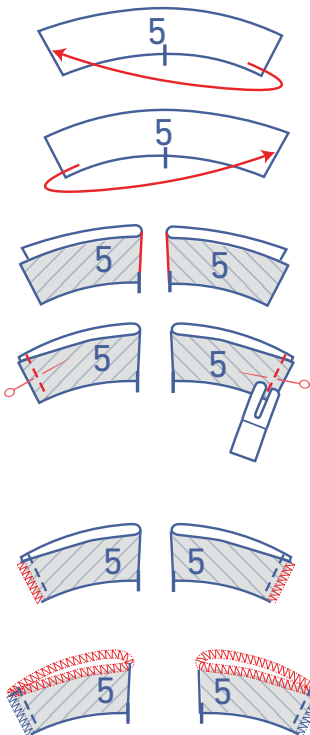

**5**

Fold the sleeve facing (5) in half with the short ends together and the right sides of the fabric touching. Pin and sew the short ends.

Finish the raw edges with overlock stitching.

Finish the unnotched ends with overlock stitching.

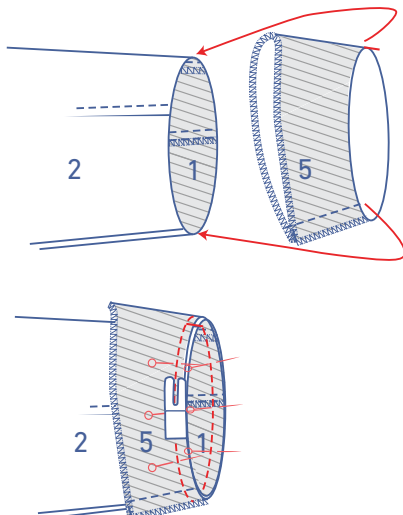

Slide the facing over the sleeve, right sides together. Pin and sew the sleeve facing so that the markings match.

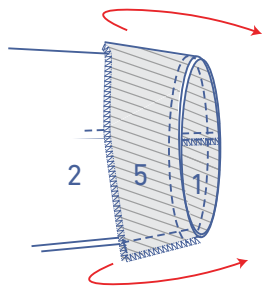

Fold the facing over the seam allowance.

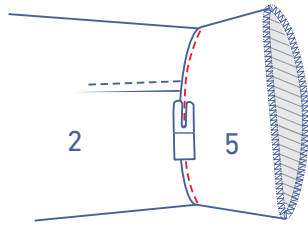
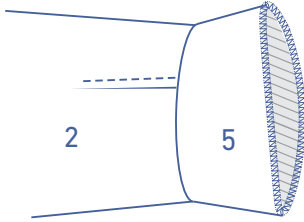

Sew the facing to the seam allowance underneath right next to the edge.

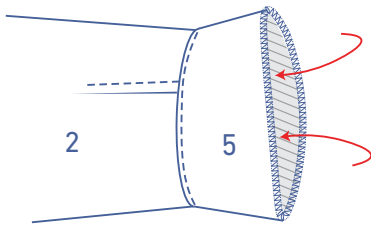
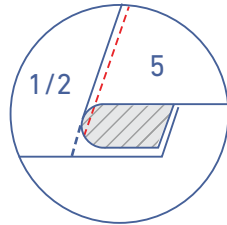

Press the facing neatly towards the wrong side and secure it to the underarm seam and the darts with just a few stitches.

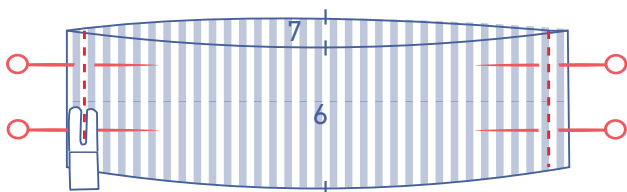
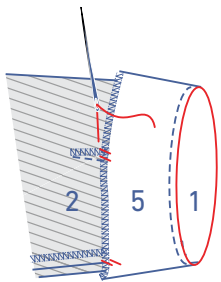

**6**

Pin and sew the side seams of the hem band front (6) and hem band back (7) together. Press the seam allowance open.

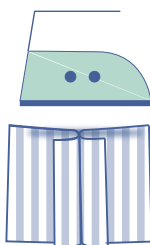

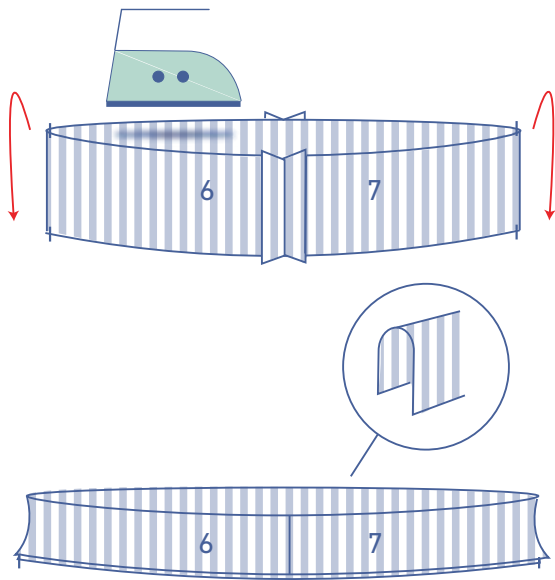

Press the hem band in half so that the long ends are together and the wrong sides of the fabric touch.

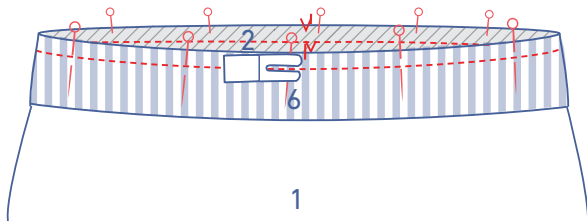

Slide the hem band over the bottom of the jumper, aligning raw edges. Pin and sew, making sure the seams and markings match. The circumference of the hem band is smaller than the circumference of the top, so stretch out the hem band as you sew.

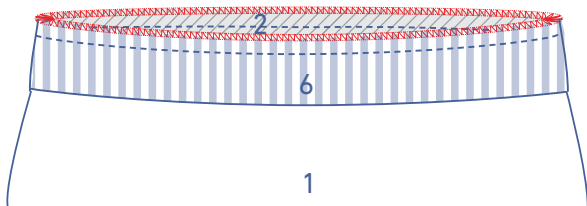

Finish the raw edges with overlock stitching.