

# Nouria by Fibre ⚡ood





# Nouria bag by Fibre ⚡ood



## supplies



- Thread
- Snap (Ø 13/16"): 1
- Lining or lightweight cotton (width 55"): 1,25 yd
- Fabric (width 35,5") : 2 yd

**NOTE:** Also provide the following supplies if you want to make the Nouria bag in a handmade matelassé fabric.

- Volume wadding (1 or 2 cm thick, width 35,5"): 1,65 yd
- Fabric spray adhesive (optional, simplifies the creative process)
- Tailor's chalk
- Metre stick ruler



## pattern pieces & seam allowances (in inches)

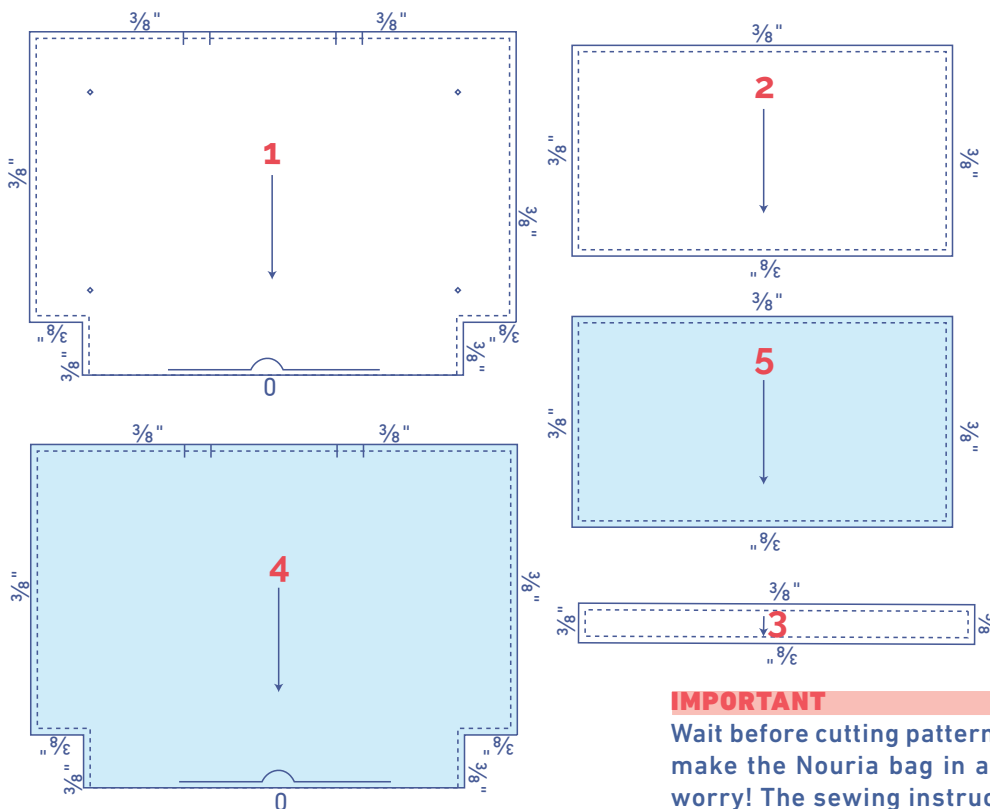

### IMPORTANT

Pattern pieces '1 and 4' and '2 and 5' are the same

1. bag: 1x on fabric fold
2. pocket: 1x
3. handle: 4x
4. bag lining: 1x on fabric fold
5. pocket lining: 1x

### IMPORTANT

Wait before cutting pattern pieces 1 and 2 from the fabric if you make the Nouria bag in a handmade matelassé fabric. Don't worry! The sewing instructions explain this process in detail.

## marking pattern pieces



Notch the pattern paper and fabric at the following points

| single notch

V V notch / fabric fold



Mark the following points using marking thread



centre point



material type



fabric



lining or lightweight cotton

# sewing instructions



Print the pattern at 100% and stick the different pieces to each other. Always sew the pieces positioned with the right sides of the fabric together, unless stated otherwise.



right side



wrong side



lining right side



lining wrong side



volume wadding

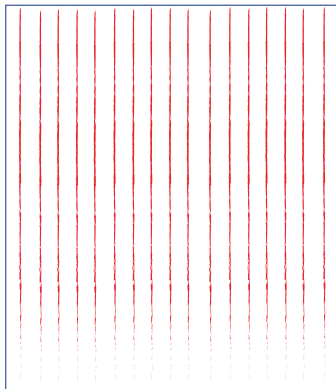
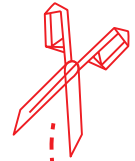

2"

## 1

### Optional

*NOTE: Follow this step if you want to make the Nouria bag in a handmade matelassé fabric and skip step 2. If not, skip straight to step 2.*

Cut a piece of fabric that is 35,5" wide and 1,65 yd long. Use the tailor's chalk to mark parallel lines 2" away from each other.

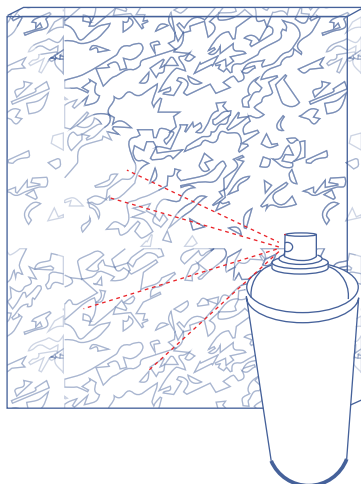

Spray a little adhesive on the volume wadding.



Stick the piece of fabric to the volume wadding.

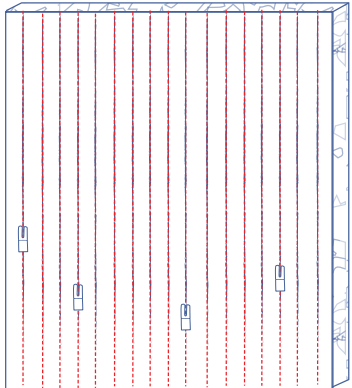

Sew along the lines drawn with the tailor's chalk through both fabric and volume wadding.

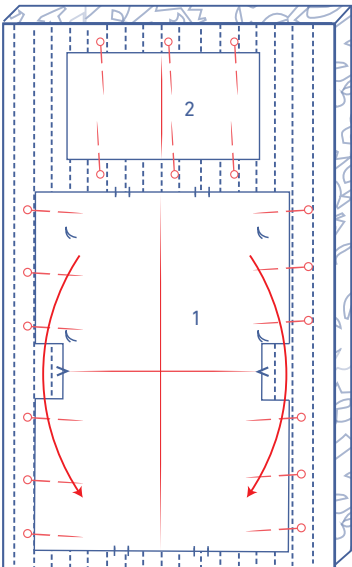

Fold the bag and the pocket pattern pieces in half crosswise down one side and then down the other so that a fold line (= centre line) is created.

Pin the centre lines exactly on one of the stitching lines of the matelassé fabric.

Cut the pocket and the top half of the bag out of the fabric. Fold the pattern piece for the bag down to the V notches so that a mirror image is created. Now cut the bottom half of the bag out.

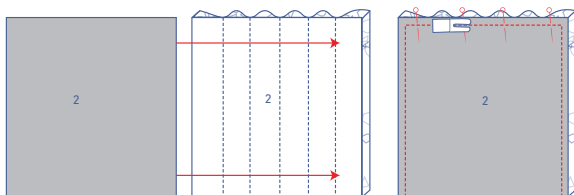

Pin and sew the edges of the pocket (lining) and the pocket (lining + volume wadding) where indicated.

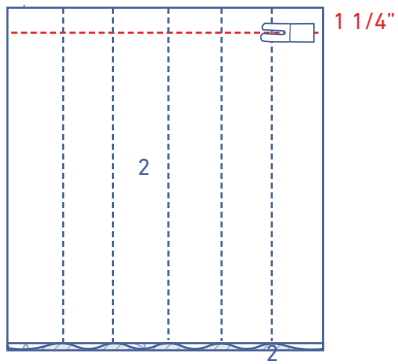

Turn the pockets right side out and sew through all layers at 1 1/4" from the top.

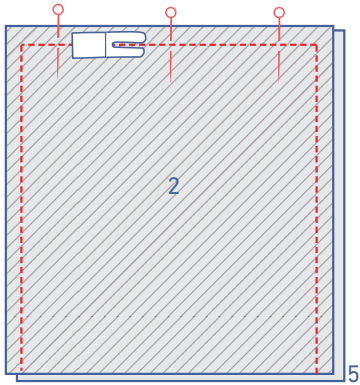

## 2

Pin and sew the edges of the pocket (2) and the pocket lining (5) where indicated.

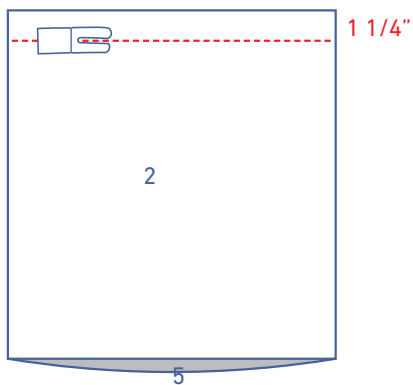

Turn the pockets right side out and sew through both layers at 1 1/4" from the top.

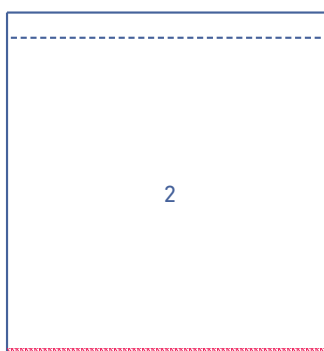

## 3

Finish the raw edges together using an overlock stitch.

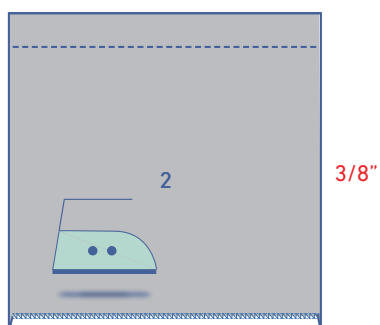

Press the indicated edge 3/8" towards the wrong side.

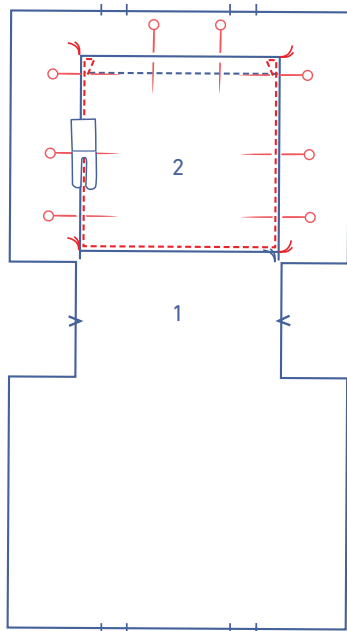

Pin the pocket to the bag (1) where indicated. Sew into place right next to the edge. Sew reinforcement triangles for the top corners.

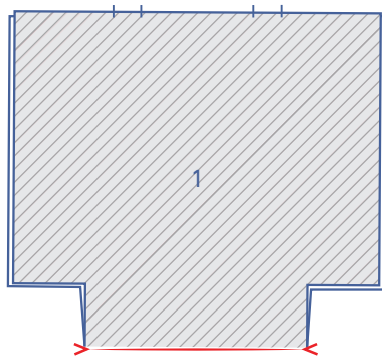

#### 4

Fold the bag in half lengthwise (straight grain) with the right side of the fabric turned inward to where the V notches are.

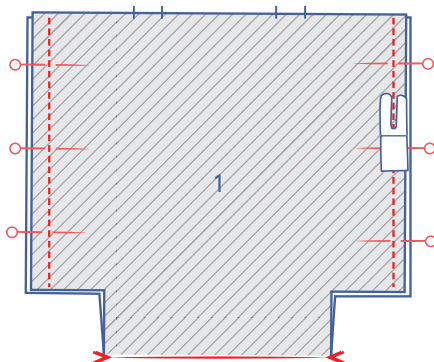

Pin and sew the sides (only the long sides).

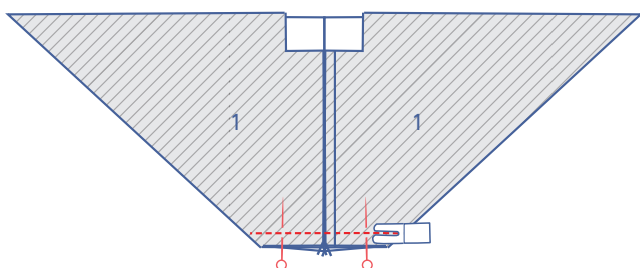

Now fold the vertical and horizontal sides to the corners with the right sides matching exactly. Sew into place.

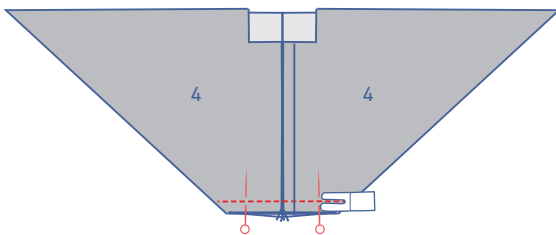
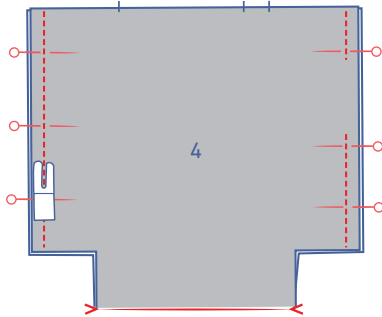
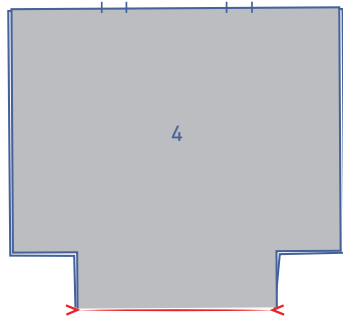

## 5

Fold the bag lining (4) in half lengthwise (straight grain) with the right side of the fabric turned inward to where the V notches are and pin the sides together.

Sew the sides, but be sure to leave an opening of 8" on one side so that you can turn the bag inside out later on.

Fold the vertical and horizontal sides to the corners with the right sides matching exactly. Sew into place.

## 6

### Optional

*NOTE: Follow this step if you want to make the Nouria bag in a handmade matelassé fabric and skip step 7a. If not, skip straight to step 7.*

Spray a little adhesive on the 2 strips of volume wadding for the handles. Stick the fabric for the handles to the strips of sprayed volume wadding.

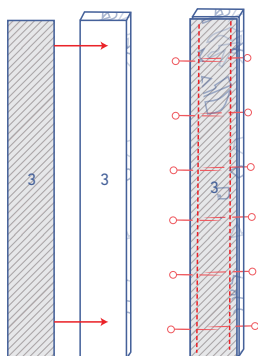
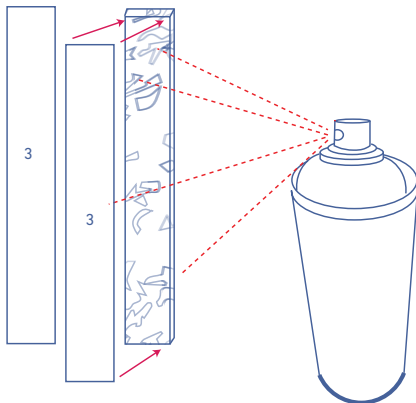

Pin the 2 remaining handle pieces (fabric) to this with the right sides of the fabric matching exactly.



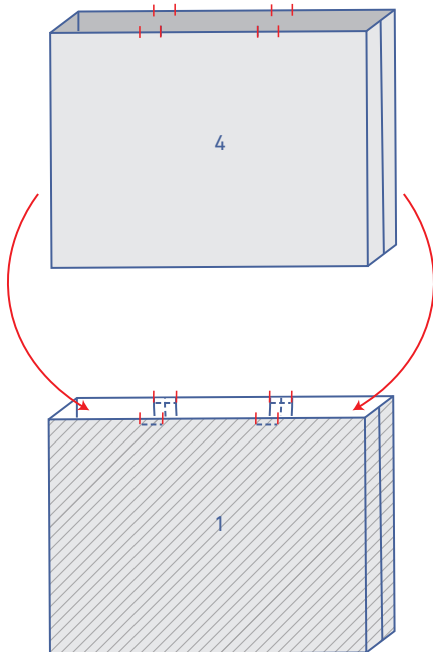
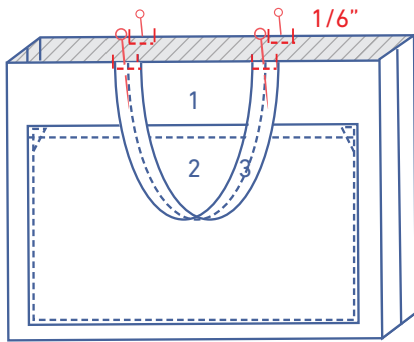
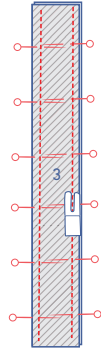

---

## 7

Pin and sew the long sides of the handle pieces (3) together. Now, turn the handles back right side out.

Sew down the centre of the handle through all layers.

Pin the raw edges of the handles between the notches in the bag and sew these into place at 1/6".

---

## 8

Slide the bag lining into the bag (turned inside out) with the right sides matching exactly.

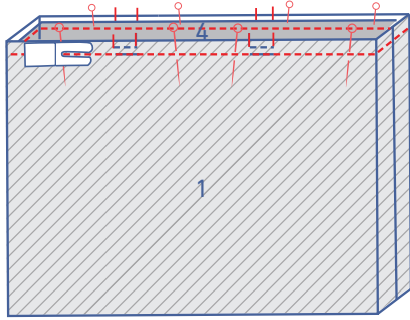

Pin and sew the tops together (with the handles between them).

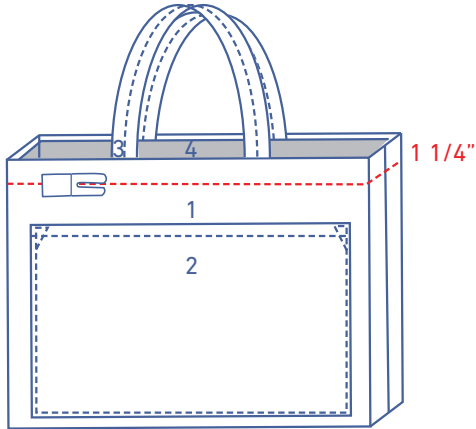

Turn the bag right side out through the opening in the bag lining and topstitch at 1 1/4" from the top. Hand sew or stitch the opening in the bag lining closed.

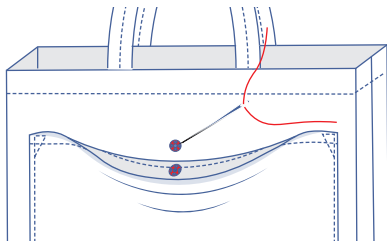

Attach the snap where indicated.