

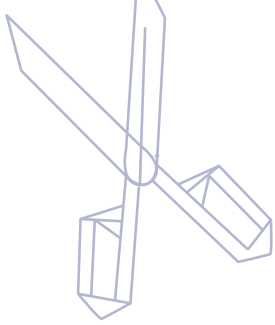

Clement by Fibre ⚡ood

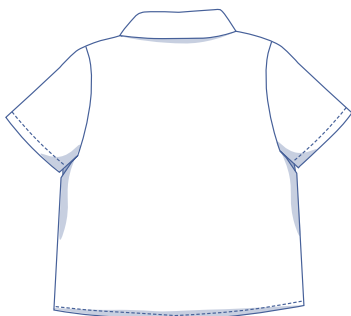

#Clement



XS - XL



Clement is an airy shirt with short sleeves, a collar and patch pockets. The straight fit is ideal for the first rays of the sun in spring. Solid colour or playful print? The sky is the limit.

size chart (in cm)

size	XS		S		M		L		XL	
body height	172	172	174	174	176	176	180	180	184	184
C (chest)	80	84	88	92	96	100	104	108	112	116

Choose your size based on your **bust measurement**. Pick the size that is the best match for your chest.



finished garment measurements (in cm)

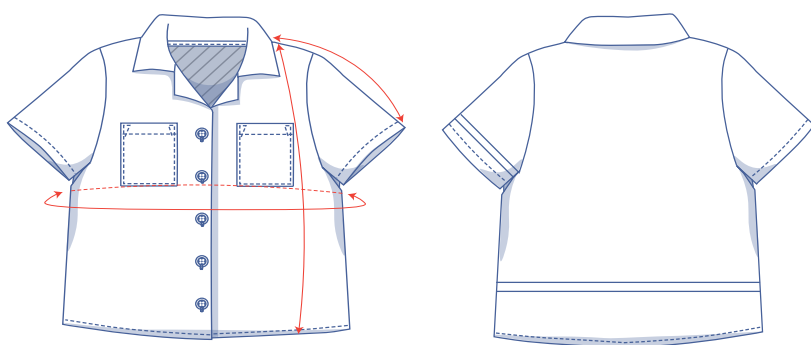

This chart's measurements are the pattern measurements based on the fabric type and serve as a reference. Ease has been added to the width measurements (in addition to the exact body measurements) for a more comfortable fit. Clement is designed to have a **comfortable cut**. Depending on the preferred cut, you could decide to go a size smaller or larger than the recommended size.

== shorten or lengthen the pattern here

size	XS	S	M	L	XL
length	66.25	67.25	68.25	69.25	70.25
sleeve length*	40.75	42.5	44	45.75	47.5
chest	94	102	110	118	126

* Including shoulder length.



Compare the stated lengths to the measured or desired lengths. **Lengthen** or **shorten** the shirt and/or the sleeves by cutting the pattern pieces at the indicated double lines and then spreading the pattern pieces out X cm from each other or overlapping them where needed. Make sure that the CF and CB lines and the side seams are always straight.

IMPORTANT

Adjust the fabric to be used based on these alterations.

Material



- Thread
- Iron-on interfacing: max. 75 cm
- Buttons (Ø 1.1 cm): 5
- Fabric: see table

fabric		XS	S	M	L	XL
fabric width 110 cm	cm	180	190	195	205	210
fabric width 140 cm	cm	115	155	175	180	185

The corresponding fabric layout can be found on page 6 of these sewing instructions.

fabric advice



A cotton weave (such as poplin, stretch cotton, denim, twill, etc.) works best for this shirt. Cotton is a sturdy fibre that easily absorbs moisture and is easy to dye or print. The dye penetrates deep into the fabric meaning that it will retain its colour for quite some time. Cotton breathes well and is easy to maintain.

Viscose is also an option. Like cotton, viscose is a versatile material, it's a breathable fabric that absorbs moisture well. Moreover, viscose is incredibly soft against the skin making it really comfortable to wear. Viscose is slightly less easy to care for than cotton: it's not suitable for washing or ironing at higher temperatures. Note that viscose is a fluid fabric with a lot of drape.

Proud to be #Sewista

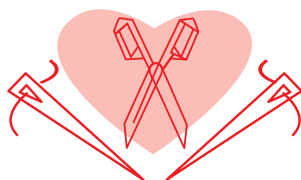

pattern pieces & seam allowances (in cm)

To sew the garment as described in the instructions, draw the illustrated seam allowances around the paper pattern pieces before cutting them out. If you are using a PDF pattern, the pattern can be printed with or without seam allowance.

To find out more, watch the [video](#).

- 1. front: 2x
- 2. back: 1x at fabric fold
- 3. sleeve: 2x
- 4. collar: 2x at fabric fold
- 5. pocket: 2x
- 6. neck bias tape: 1x

IMPORTANT

The pieces highlighted in light yellow have iron-on interfacing attached to the wrong side.

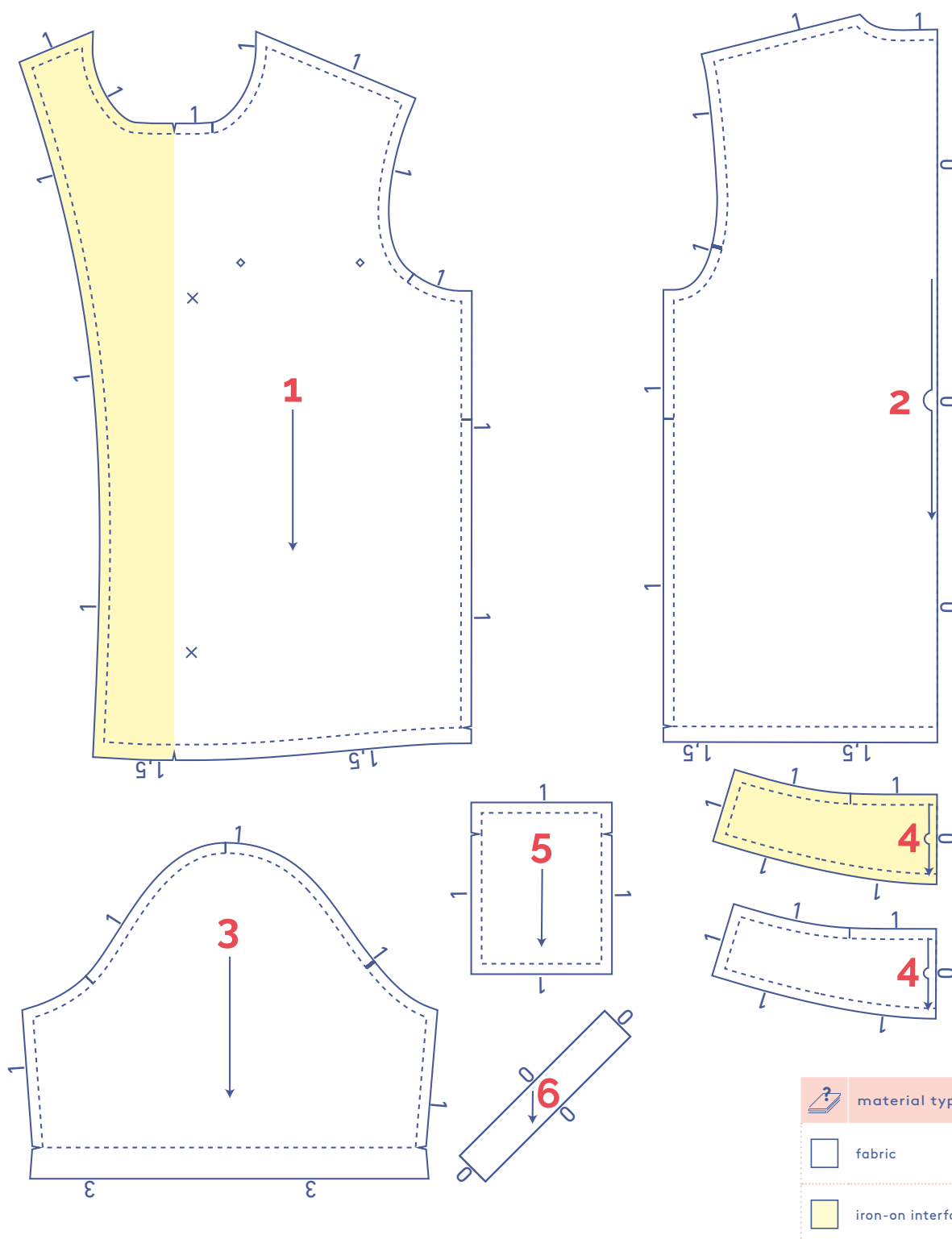

fabric layout – solid fabrics
fabric width 110 cm

XS - XL

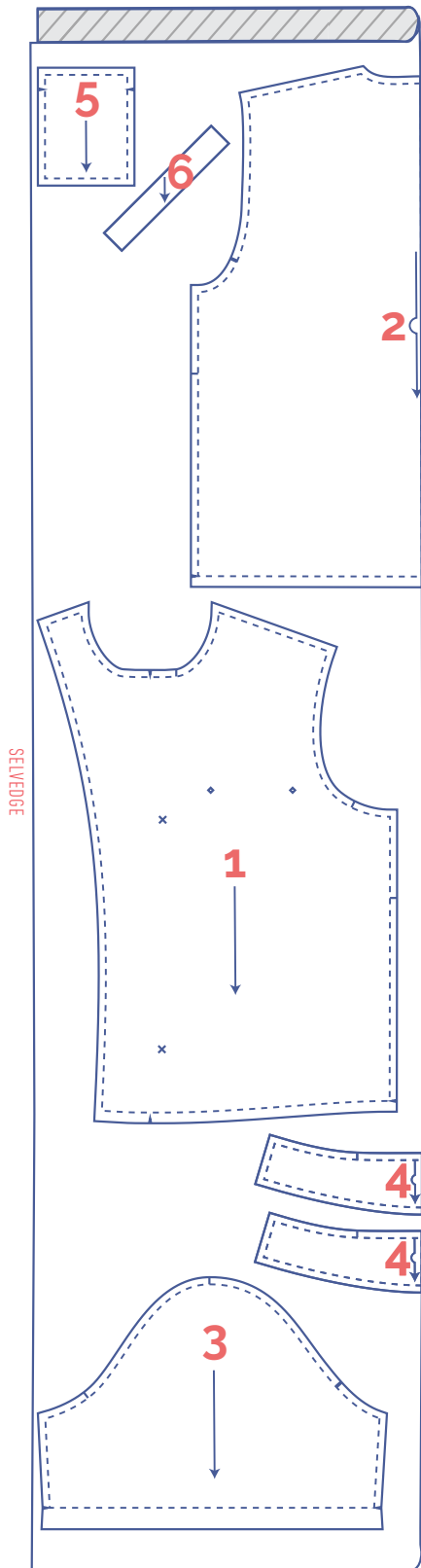

IMPORTANT

You only need pattern piece 6 once.

fabric layout – solid fabrics
fabric width 140 cm

XS

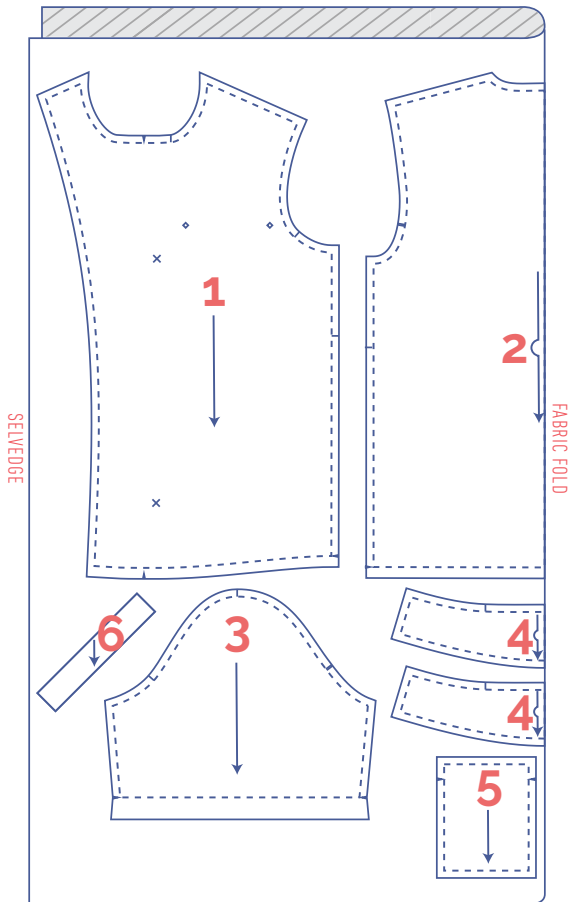

IMPORTANT

You only need pattern piece 6 once.

marking pattern pieces

	Notch the pattern paper and fabric at the following points
	single notch
	double notch
V	V notch

	Mark the following points using marking thread
	centre point
	snap/button

S - XL

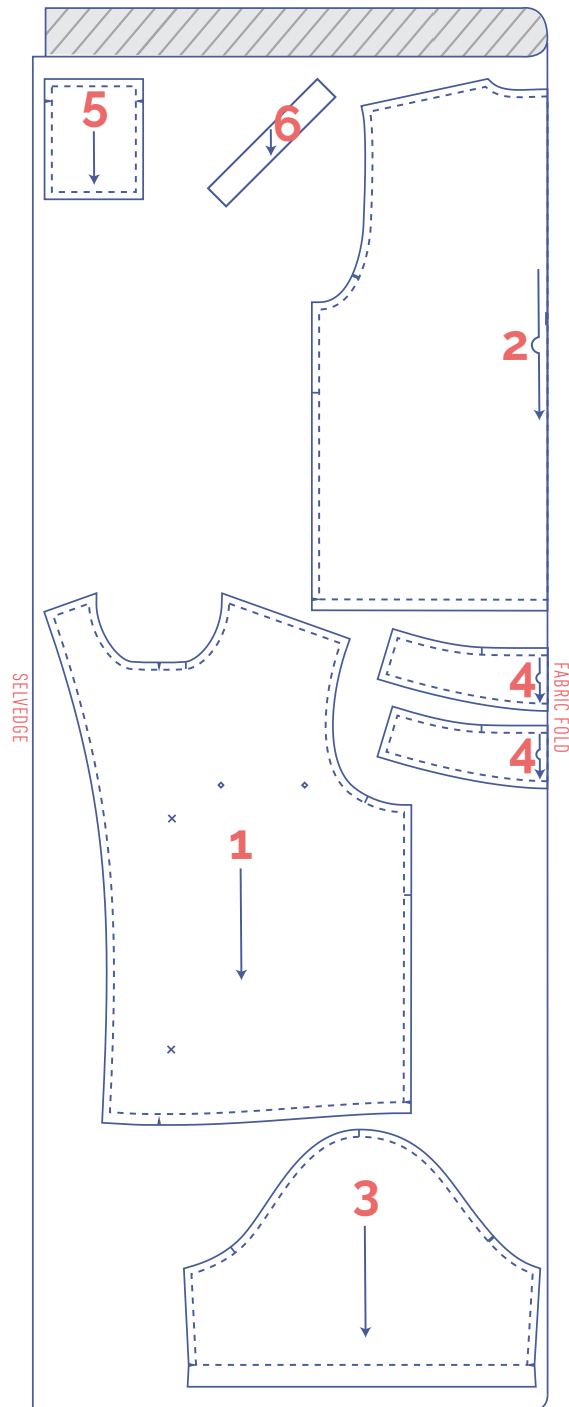

IMPORTANT

You only need pattern piece 6 once.



casual

sewing instructions



The method used to finish sewing the garment depends on the fabric used. The pieces are always sewn together with the right sides together, unless stated otherwise.

F front

B back

CF centre front

CB centre back

RF right front

LF left front

 right side

 wrong side

 iron-on interfacing

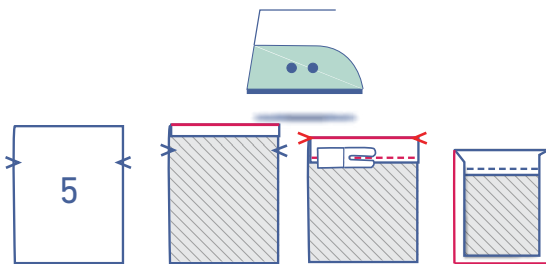
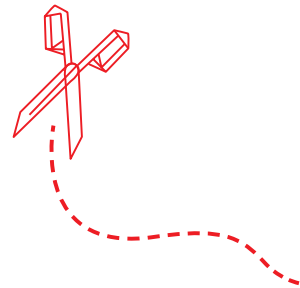
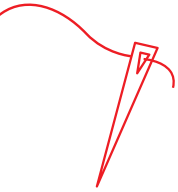

1

Press the top of the pocket (5) over by 1cm to the wrong side, then fold over and press again at the V notches. Next, sew in place right next to the edge. Press the seam allowance (1 cm) of the remaining 3 sides over to the wrong side.

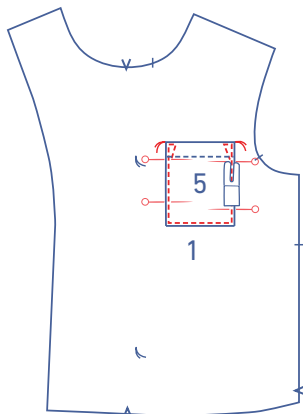

Pin the pocket at the place indicated on the front (1). Sew in place right next to the edge. At the top, sew reinforcement triangles on both sides.

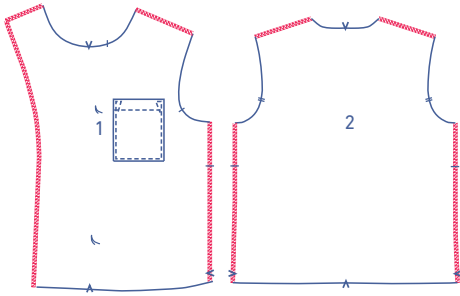

2

Overlock the edges of the front (1), back (2) and sleeve (3) as shown.

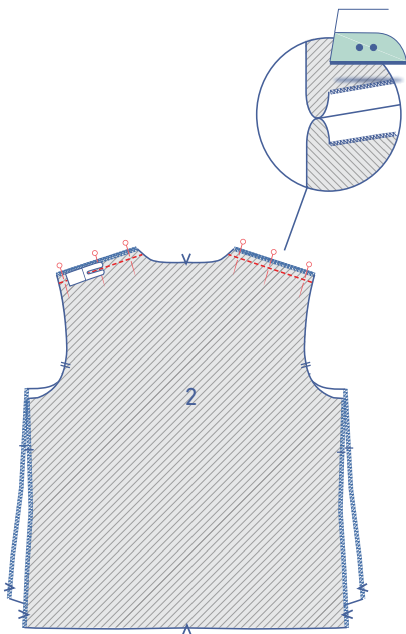
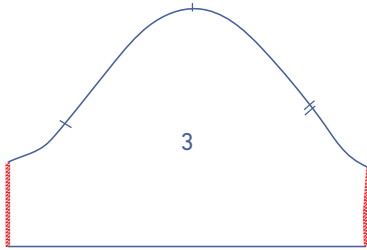

Pin and sew the shoulder seams of the front and back and press the seam allowance open.

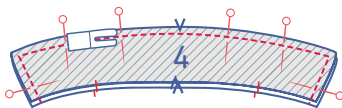

3

Pin and sew the collars (4) around the edges shown. Trim the corners to reduce bulk. Turn the right way out.

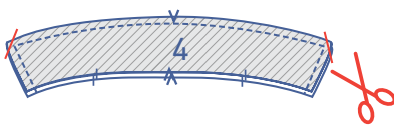

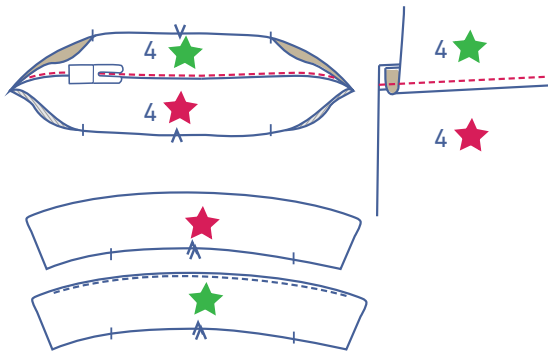

Open the collar back out. The top collar (= visible when you're wearing the shirt) has been indicated with a small red star, while the undercollar has been indicated with a small green star. Fold the seam allowance towards the undercollar (= small green star). Sew at 2 mm from the seam through all layers (undercollar + seam allowance). Give the collar a press.

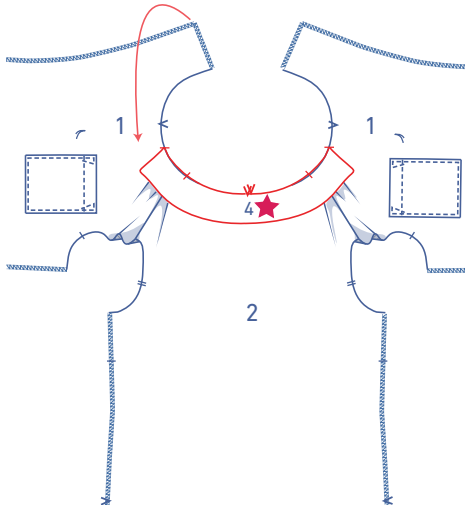

Pin the unfinished raw edges of the collar to the neckline. The upper collar should be on top. The short ends of the collar should line up with the notch on the neckline. The notch on the collar should line up with the shoulder seam. The V notch indicating the middle of the collar should line up with the V notch indicating the middle of the back.

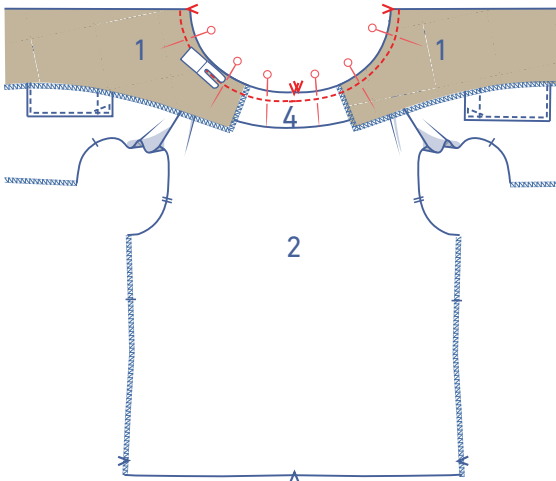

Fold the shaped facing of the front over to the wrong side at the V notch. Line up the raw edges of the front's neckline with the raw edges of the shaped facing's neckline. Sew the neckline in place from V notch to V notch, catching the collar in between.

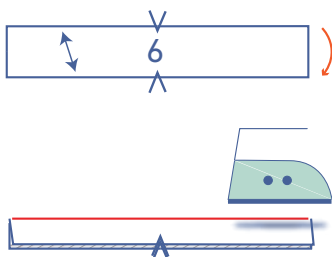

Press the bias tape for the neck (6) in half lengthwise with the right side of the fabric facing outwards.

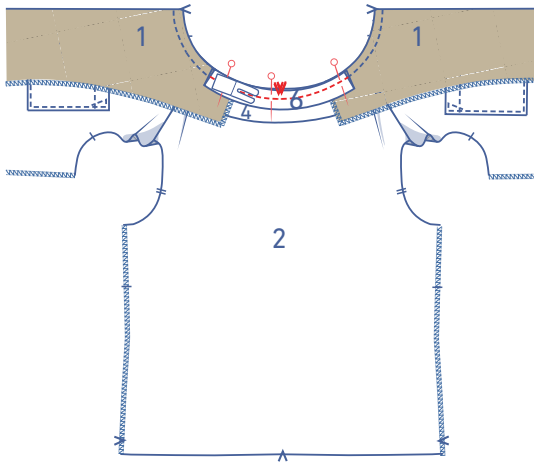

Line up the unfinished raw edges of the bias tape with the neckline. The bias tape should be on top of the collar and the folded over shaped facing of the front. Pin and sew in place.

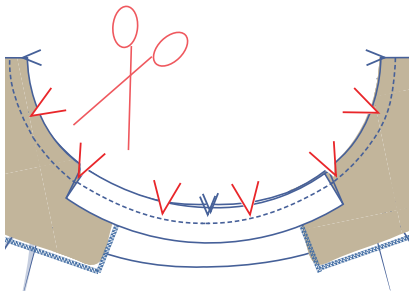

In the curve of the neckline, cut V notches out of the seam allowance and trim the seam allowance to make it a little smaller.

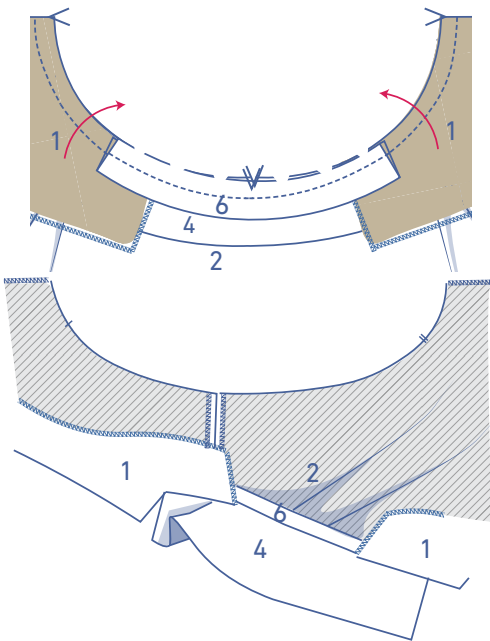

Turn the shaped facing and the bias tape back to the wrong side.

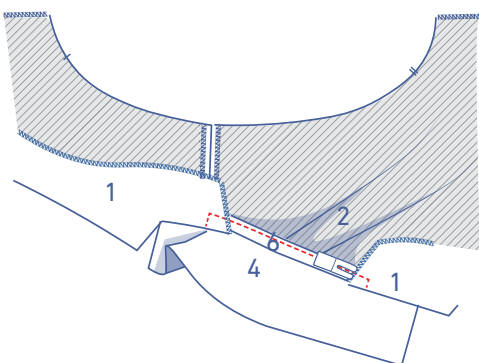

Sew the bias tape in place along the folded edge from shoulder seam to shoulder seam. Sew at an angle up to the neckline.

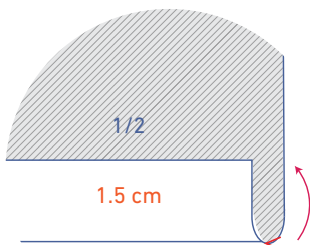
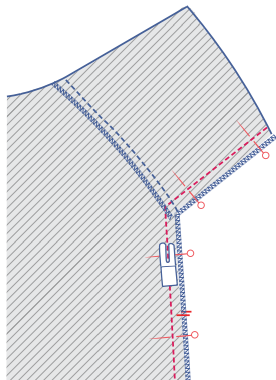
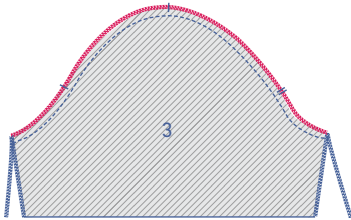
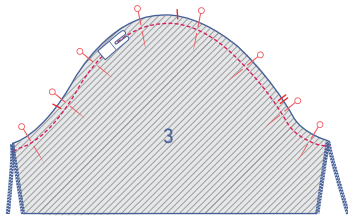
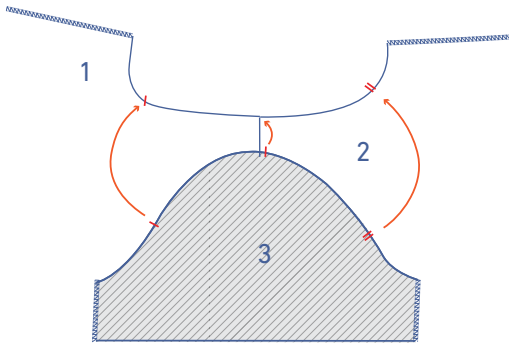

4

Pin and sew the top of the sleeve (= the sleeve cap), matching notches. The single notch marks the front, while the double nicks mark the back. The single notch at the top matches the shoulder seam exactly. Distribute the 'excess' fabric evenly between the nicks.

Finish the raw edges together using an overlock stitch.

5

Fold the sleeve and the shirt in half with the right side of the fabric facing inwards. Pin and sew the side and underarm seams in place. Press the seam allowance open.

6

Fold the hem 1.5 cm over and open back out.

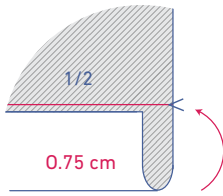

Fold the raw edge of the hem onto the pre-pressed fold line and then fold over a second time.

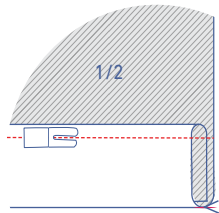
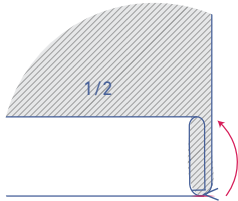

Sew in place right next to the edge.

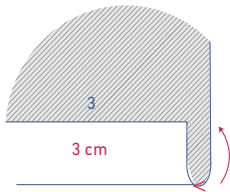

Fold the sleeve hem 3 cm over and open back out.

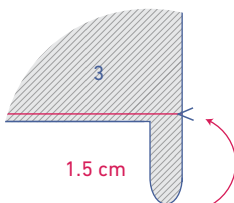
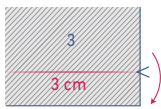

Fold the raw edge of the sleeve hem onto the pre-pressed fold line and then fold over a second time.

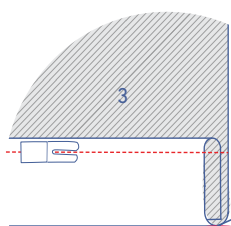
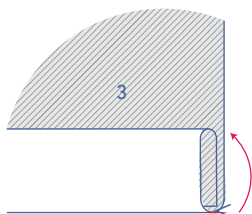

Sew in place right next to the edge.

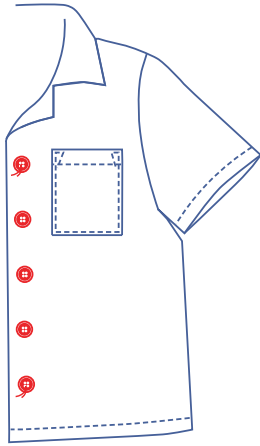

7

Sew on the buttons. The top and bottom button are marked on the pattern. Divide the distance equally to determine the position of the other buttons.

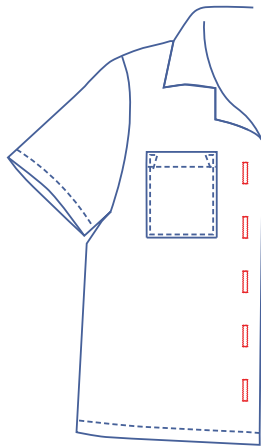

Make vertical buttonholes in the LF based on the location of the buttons.

#Clement

