

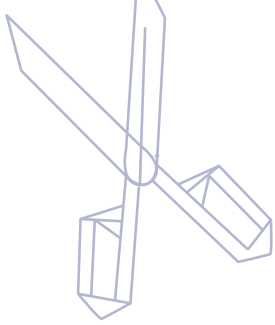

James by Fibre ood

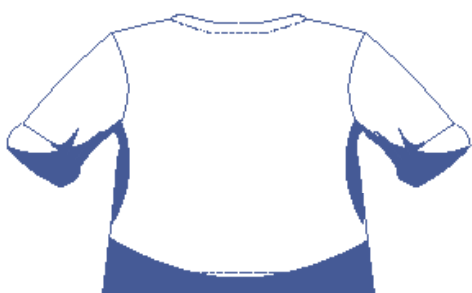

# # James



**XS - XL**



James is a unisex boat neck T-shirt and a must have for every wardrobe. The sleeves can be worn rolled up into cuffs. Get creative with the grainline on the chest pocket or use a contrasting fabric to add your own twist on the James.

## size chart (in inches)

size	XS		S		M		L		XL	
body height	67,8	67,8	68,6	68,6	69,3	69,3	70,9	70,9	72,5	72,5
<b>B (bust)</b>	31,5	33,1	34,7	36,3	37,8	39,4	41	42,6	44,1	45,7

Choose your size based on your **bust measurement**.

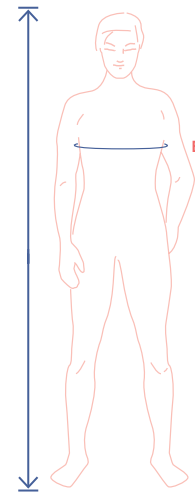

## finished garment measurements (in inches)

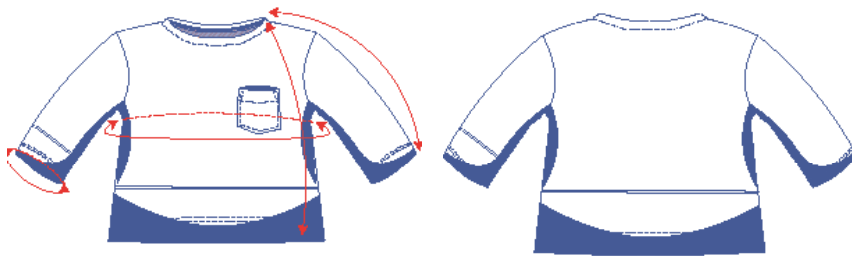

== shorten or lengthen the pattern here

This chart's measurements are the pattern measurements based on the fabric type and serve as a reference. Ease has been added to the width measurements (in addition to the exact body measurements) for a more comfortable fit. Hugo is designed to have a **comfortable cut**. Depending on the preferred cut, you could decide to go a size smaller or larger than the recommended size.

size	XS	S	M	L	XL
length	26.2	26.6	26.9	27.3	27.7
sleeve length*	27.6	28	28.5	28.9	29.4
chest	37.6	40.8	43.9	47.1	50.2
hem circumference sleeve	10.1	10.5	10.9	11.3	11.7

\* Including shoulder length.

Compare the stated lengths to the measured or desired lengths. **Lengthen** or **shorten** the T-shirt and/or the sleeves by cutting the pattern pieces at the indicated double lines. Then either increase the distance between the cut pieces by the desired amount (to lengthen), or overlap the pieces (to shorten). Make sure that the CF and CB lines and the side seams are always straight.



### IMPORTANT

Adapt the amount of fabric based on these alterations.

## notions

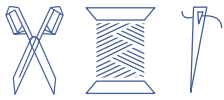

- Thread
- Bias tape: see table
- Fabric: see table

fabric		XS	S	M	L	XL
fabric width 43"	yd	1 ¾	2 ½	2 ½	2 ½	2 ½
fabric width 55"	yd	1 ½	1 ½	1 ½	1 ½	1 ½

The corresponding fabric layout can be found on page 6 of these sewing instructions.

bias tape		XS	S	M	L	XL
length	yd	0.57	0.59	0.60	0.62	0.63

## fabric advice



The James T-shirt pattern is designed for stretch knits only. Viscose jersey, cotton jersey, French terry, stretch velvet and neoprene are all great options.

# Proud to be #Sewista

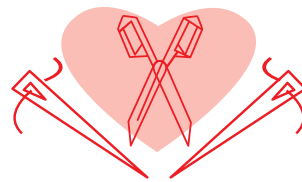



## pattern pieces & seam allowances (in inches)

To sew the garment as described in the instructions, draw the illustrated seam allowances around the paper pattern pieces before cutting them out. If you are using a PDF pattern, the pattern can be printed with or without seam allowance.

To find out more, watch the [video](#).

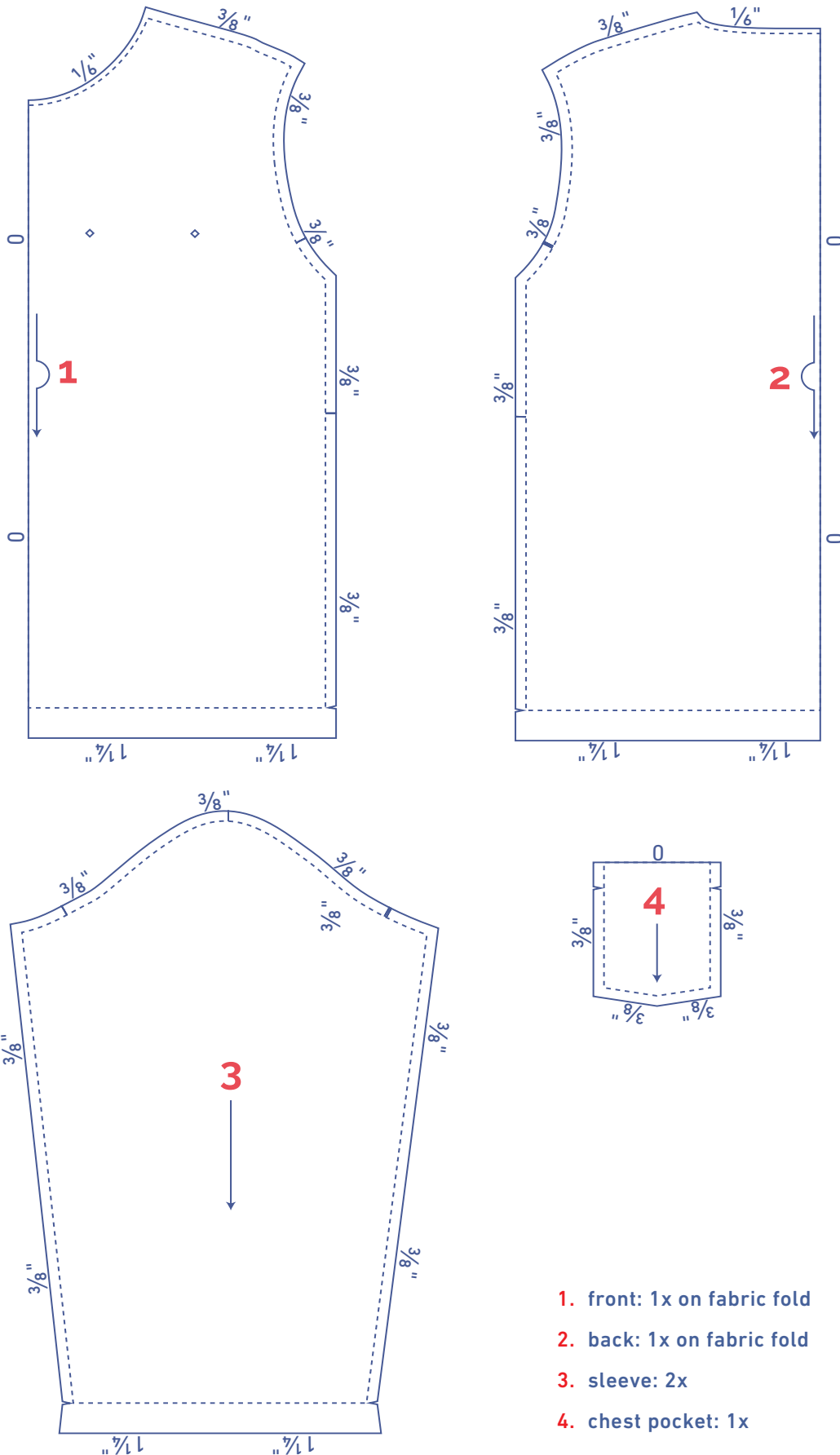

1. front: 1x on fabric fold
2. back: 1x on fabric fold
3. sleeve: 2x
4. chest pocket: 1x

## fabric layout for fabrics 43" wide

XS

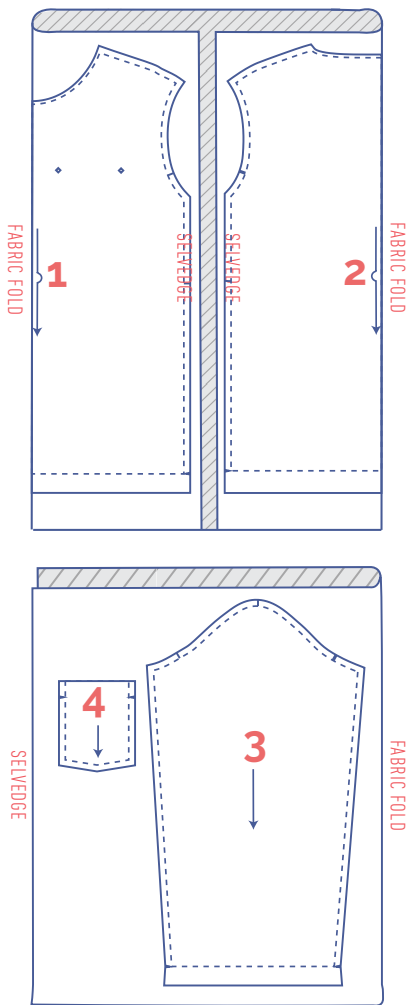

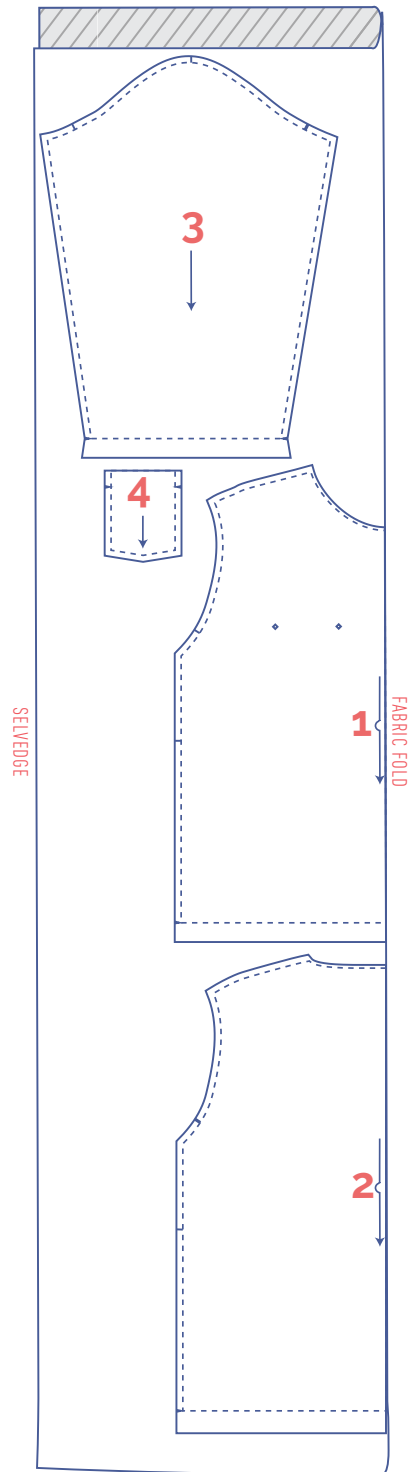

S - XL



### IMPORTANT

You only need pattern piece 4 once.

### marking pattern pieces

	Notch the pattern paper and fabric at the following points
	single notch
	double notch
V	V notch
	Mark the following points using marking thread
	centre point

### IMPORTANT

You only need pattern piece 4 once.

## fabric layout for fabrics 43" wide

XS - XL

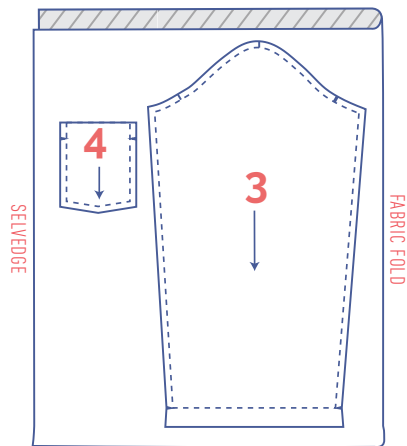
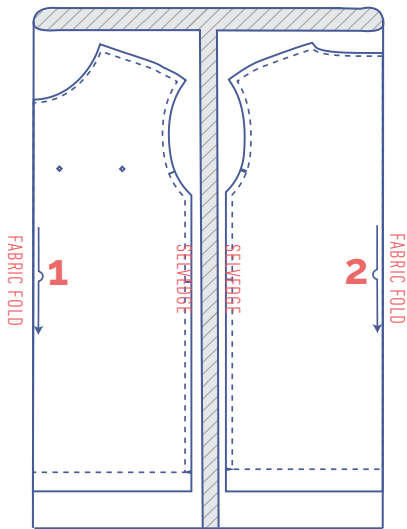



### IMPORTANT

You only need pattern piece 4 once.

## marking pattern pieces

	Notch the pattern paper and fabric at the following points
	single notch
	double notch
V	V notch

	Mark the following points using marking thread
	centre point

casual



# sewing instructions



The method used to finish the garment will depend on your chosen fabric. The pieces are always sewn together with right sides facing, unless stated otherwise.

F front

B back

CF centre front

CB centre back

 right side

 wrong side

 bias tape

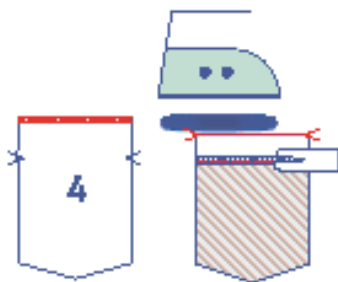

**1**

Finish the top of the pocket (4) with an overlock stitch. Now, press over at the V notches. Sew into place.

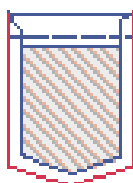

Press the remaining pocket edges 3/8" onto the wrong side.

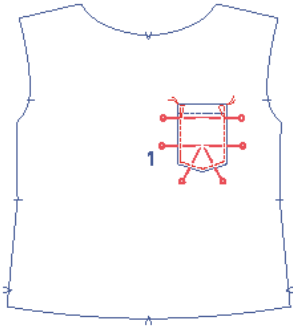

Pin the pocket in the place indicated on the front (1). Sew into place right next to the edge. At the top, sew reinforcement triangles on both sides.

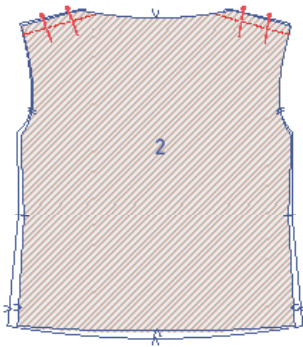

## 2

Pin and sew the shoulder seams.

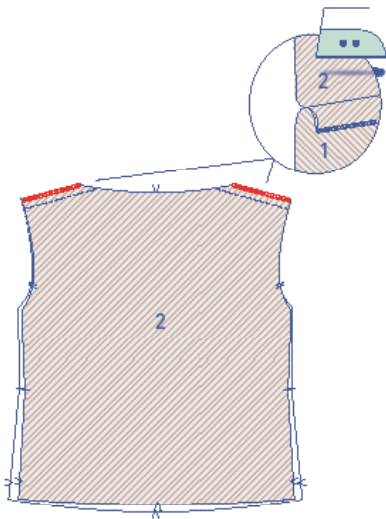

Finish the raw edges together with overlock stitching. Press the seam allowance towards the front.

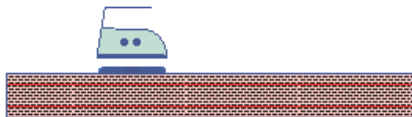

## 3

Press open, the pre-folded lines of the bias binding.

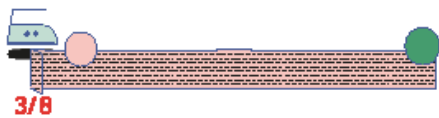

Press one short end of the bias binding over onto the wrong side (pink dot). Press the bias binding in half lengthwise with the right side of the fabric facing outwards.

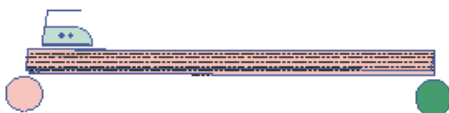

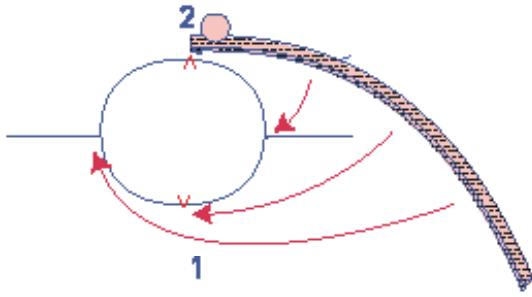

With raw edges together, pin the bias binding to the neckline along the right side. The folded over end should line up with the CB.

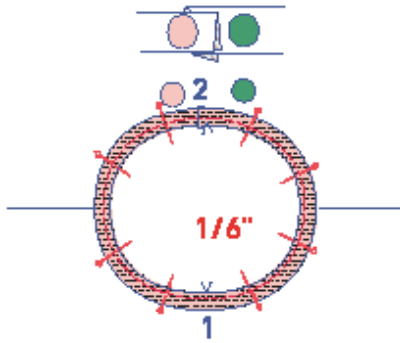

The end of the bias binding without the fold will end up sitting on top of the folded end.

Sew into place at 1/6" from the raw edge.

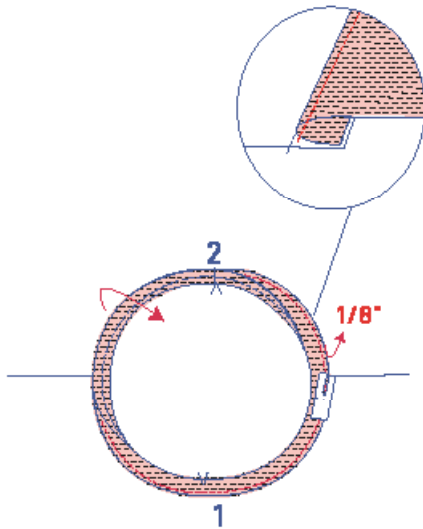

Fold the bias binding and seam allowance towards the neck opening and understitch the bias at 1/8" from the seam through all layers (bias binding & seam allowance).

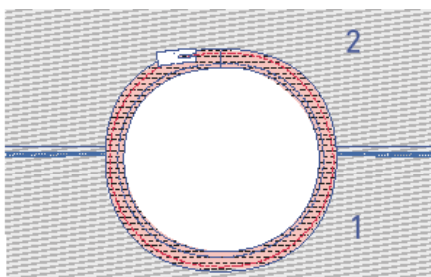

Fold the bias tape all the way over to the wrong side and sew it into place right next to the edge.

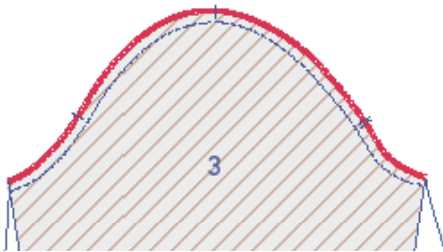
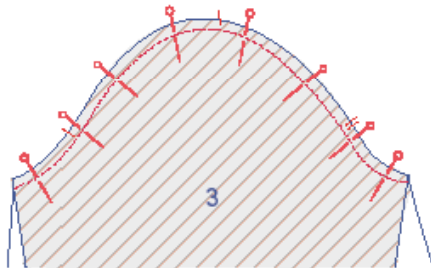
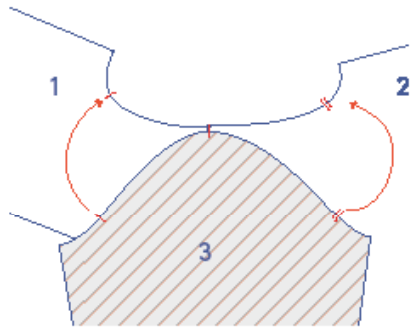

---

## 4

Pin and sew the top of the sleeve (3) (= the sleeve cap ) to the armhole with the corresponding markings matching. The single nick marks the front, while the double nicks mark the back. The top nick should line up with the shoulder seam.

Finish the raw edges together with overlock stitching.

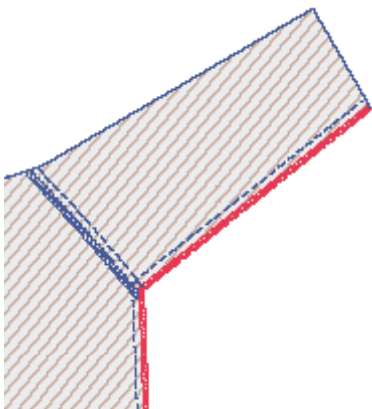
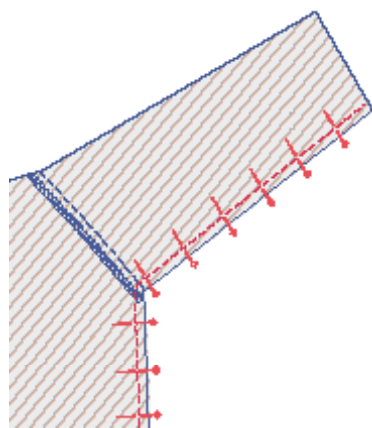

---

## 5

Pin and sew the side and underarm seams.

Finish the raw edges together with overlock stitching.



## 6

Finish the hem and sleeve hem with overlock stitching.

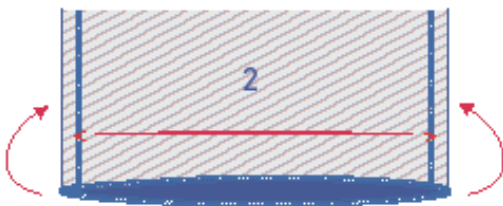

Press the hem and the sleeve hems over at the V notches.

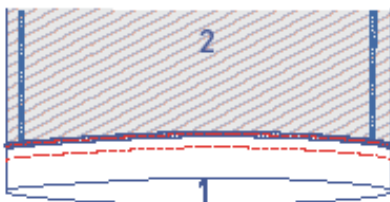
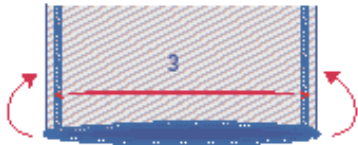

Stitch the hem allowance into place with two rows of topstitching using a ballpoint needle.

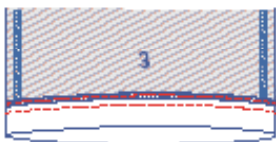

#  
J  
a  
m  
e  
s

